

# *EtherCAT*

---

Operation Manual Eighth Edition

Programming Type Controller Edition



Overview	Chapter 1
EtherCAT® Specifications	Chapter 2
XSEL-R(A)/S(A)/R(A)X/S(A)X/R(A)XD/S(A)XD	Chapter 3
Table-top Robot TTA	Chapter 4
MSEL	Chapter 5
Appendix	Chapter 6



## Please Read Before Use

Thank you for purchasing our product.

This instruction manual explains the handling methods, structure and maintenance of this product, providing the information you need in order to use the product safely.

Before using the product, be sure to read this manual and fully understand the contents explained herein to ensure safe use of the product.

Please download the user's manual from our website.

You can download it free of charge. User registration is required for the first time downloading.

URL : [www.iai-robot.co.jp/data\\_dl/CAD\\_MANUAL/](http://www.iai-robot.co.jp/data_dl/CAD_MANUAL/)

When using the product, print out of the necessary portions of the relevant manual, or please display it on your computer, tablet terminal, etc. so that you can check it immediately.

After reading the instruction manual, keep it in a convenient place so that whoever is handling the product can refer to it quickly when necessary.

### [Important]

- This Operation Manual is original.
- IAI shall not be liable whatsoever for any loss or damage arising from the result of using the product for any other purpose from what is noted in the manual.
- The information contained in this Operation Manual is subject to change without notice for the purpose of production improvement.
- If you have any question or finding regarding the information contained in this Operation Manual, contact our customer center or our sales office near you.
- Using or copying all or a part of this Operation Manual without permission is prohibited.
- The company names, names of products, and trademarks of each company referenced in this document are registered trademarks.
- EtherCAT® is a trademark used under the license of Beckoff Automation GmbH.



## Table of Contents

Safety Guide.....	1
Caution in Handling .....	8
1. Overview .....	9
2. EtherCAT® Specifications.....	11
3. XSEL-R(A)/S(A)/R(A)X/S(A)X/R(A)XD/S(A)XD.....	13
3.1 Operation Modes and Functions .....	13
3.2 Model.....	14
3.3 EtherCAT® Interface .....	15
3.3.1 Names of the Parts.....	15
3.3.2 Monitor LED indications .....	16
3.4 Wiring.....	17
3.4.1 Wiring (example).....	17
3.4.2 Connector Pin Layout.....	17
3.5 Setting.....	18
3.5.1 Parameter Setting .....	18
3.5.2 Example for Parameter Settings .....	21
3.6 Standard I/O Ports of XSEL Controller.....	27
3.7 I/O Port and Data Reading and Writing.....	28
4. Table-top Robot TTA .....	31
4.1 Operation Modes and Functions .....	31
4.2 Model.....	32
4.3 EtherCAT® Interface .....	33
4.3.1 Names of the Parts.....	33
4.3.2 Monitor LED indications .....	34
4.4 Wiring.....	35
4.4.1 Wiring (example).....	35
4.4.2 Connector Pin Layout.....	35
4.5 Setting.....	36
4.5.1 Parameter Setting .....	36
4.5.2 Example for Parameter Settings .....	39
4.6 I/O Ports of TTA.....	45
4.7 I/O Port and Data Reading and Writing.....	47
5. MSEL .....	49
5.1 Operation Modes and Functions .....	49
5.2 Model.....	50
5.3 EtherCAT® Interface .....	50
5.3.1 Name of the Parts .....	50
5.3.2 Monitor LED indications .....	51
5.4 Wiring.....	52
5.4.1 Wiring (example).....	52
5.4.2 Connector Pin Layout.....	52
5.5 Setting.....	53
5.5.1 Parameter Setting .....	53
5.5.2 Example for Parameter Settings .....	56
5.6 I/O Ports of MSEL.....	58
5.7 I/O Port and Data Reading and Writing.....	60

6. Appendix ..... 63

    6.1 Troubleshooting ..... 63

    6.2 List of EtherCAT® Related Parameters ..... 65

    6.3 Network Setting File ..... 70

    6.4 Example for Connectivity Setting ..... 71

        6.4.1 Sysmac Studio Startup and PLC Communication Connectivity ..... 71

        6.4.2 Installing Setting File for Network (ESI File) ..... 73

        6.4.3 Setup of EtherCAT Network Configuration ..... 76

        6.4.4 Changing PDO Mapping Setting ..... 80

        6.4.5 Data Transfer to PLC ..... 85

Change History ..... 87

## Safety Guide

“Safety Guide” has been written to use the machine safely and so prevent personal injury or property damage beforehand. Make sure to read it before the operation of this product.

### Safety Precautions for Our Products

The common safety precautions for the use of any of our robots in each operation.

No.	Operation Description	Description
1	Model Selection	<ul style="list-style-type: none"> <li>● This product has not been planned and designed for the application where high level of safety is required, so the guarantee of the protection of human life is impossible. Accordingly, do not use it in any of the following applications.               <ol style="list-style-type: none"> <li>1) Medical equipment used to maintain, control or otherwise affect human life or physical health.</li> <li>2) Mechanisms and machinery designed for the purpose of moving or transporting people (For vehicle, railway facility or air navigation facility)</li> <li>3) Important safety parts of machinery (Safety device, etc.)</li> </ol> </li> <li>● Do not use the product outside the specifications. Failure to do so may considerably shorten the life of the product.</li> <li>● Do not use it in any of the following environments.               <ol style="list-style-type: none"> <li>1) Location where there is any inflammable gas, inflammable object or explosive</li> <li>2) Place with potential exposure to radiation</li> <li>3) Location with the ambient temperature or relative humidity exceeding the specification range</li> <li>4) Location where radiant heat is added from direct sunlight or other large heat source</li> <li>5) Location where condensation occurs due to abrupt temperature changes</li> <li>6) Location where there is any corrosive gas (sulfuric acid or hydrochloric acid)</li> <li>7) Location exposed to significant amount of dust, salt or iron powder</li> <li>8) Location subject to direct vibration or impact</li> </ol> </li> <li>● For an actuator used in vertical orientation, select a model which is equipped with a brake. If selecting a model with no brake, the moving part may drop when the power is turned OFF and may cause an accident such as an injury or damage on the work piece.</li> </ul>

No.	Operation Description	Description
2	Transportation	<ul style="list-style-type: none"> <li>● When carrying a heavy object, do the work with two or more persons or utilize equipment such as crane.</li> <li>● When the work is carried out with 2 or more persons, make it clear who is to be the “leader” and who to be the “follower(s)” and communicate well with each other to ensure the safety of the workers.</li> <li>● When in transportation, consider well about the positions to hold, weight and weight balance and pay special attention to the carried object so it would not get hit or dropped.</li> <li>● Transport it using an appropriate transportation measure. The actuators available for transportation with a crane have eyebolts attached or there are tapped holes to attach bolts. Follow the instructions in the instruction manual for each model.</li> <li>● Do not step or sit on the package.</li> <li>● Do not put any heavy thing that can deform the package, on it.</li> <li>● When using a crane capable of 1t or more of weight, have an operator who has qualifications for crane operation and sling work.</li> <li>● When using a crane or equivalent equipments, make sure not to hang a load that weighs more than the equipment’s capability limit.</li> <li>● Use a hook that is suitable for the load. Consider the safety factor of the hook in such factors as shear strength.</li> <li>● Do not get on the load that is hung on a crane.</li> <li>● Do not leave a load hung up with a crane.</li> <li>● Do not stand under the load that is hung up with a crane.</li> </ul>
3	Storage and Preservation	<ul style="list-style-type: none"> <li>● The storage and preservation environment conforms to the installation environment. However, especially give consideration to the prevention of condensation.</li> <li>● Store the products with a consideration not to fall them over or drop due to an act of God such as earthquake.</li> </ul>
4	Installation and Start	<p>(1) Installation of Robot Main Body and Controller, etc.</p> <ul style="list-style-type: none"> <li>● Make sure to securely hold and fix the product (including the work part). A fall, drop or abnormal motion of the product may cause a damage or injury. Also, be equipped for a fall-over or drop due to an act of God such as earthquake.</li> <li>● Do not get on or put anything on the product. Failure to do so may cause an accidental fall, injury or damage to the product due to a drop of anything, malfunction of the product, performance degradation, or shortening of its life.</li> <li>● When using the product in any of the places specified below, provide a sufficient shield.             <ol style="list-style-type: none"> <li>1) Location where electric noise is generated</li> <li>2) Location where high electrical or magnetic field is present</li> <li>3) Location with the mains or power lines passing nearby</li> <li>4) Location where the product may come in contact with water, oil or chemical droplets</li> </ol> </li> </ul>

No.	Operation Description	Description
4	Installation and Start	<p>(2) Cable Wiring</p> <ul style="list-style-type: none"> <li>● Use our company's genuine cables for connecting between the actuator and controller, and for the teaching tool.</li> <li>● Do not scratch on the cable. Do not bend it forcibly. Do not pull it. Do not coil it around. Do not insert it. Do not put any heavy thing on it. Failure to do so may cause a fire, electric shock or malfunction due to leakage or continuity error.</li> <li>● Perform the wiring for the product, after turning OFF the power to the unit, so that there is no wiring error.</li> <li>● When the direct current power (+24V) is connected, take the great care of the directions of positive and negative poles. If the connection direction is not correct, it might cause a fire, product breakdown or malfunction.</li> <li>● Connect the cable connector securely so that there is no disconnection or looseness. Failure to do so may cause a fire, electric shock or malfunction of the product.</li> <li>● Never cut and/or reconnect the cables supplied with the product for the purpose of extending or shortening the cable length. Failure to do so may cause the product to malfunction or cause fire.</li> </ul> <hr/> <p>(3) Grounding</p> <ul style="list-style-type: none"> <li>● The grounding operation should be performed to prevent an electric shock or electrostatic charge, enhance the noise-resistance ability and control the unnecessary electromagnetic radiation.</li> <li>● For the ground terminal on the AC power cable of the controller and the grounding plate in the control panel, make sure for grounding work. For security grounding, it is necessary to select an appropriate wire thickness suitable for the load. Perform wiring that satisfies the specifications (electrical equipment technical standards). For detail, follow the description in an instruction manual of each controller or controller built-in actuator.</li> <li>● Perform Class D Grounding (former Class 3 Grounding with ground resistance 100Ω or below).</li> </ul>





No.	Operation Description	Description
4	Installation and Start	<p>(4) Safety Measures</p> <ul style="list-style-type: none"> <li>● When the work is carried out with 2 or more persons, make it clear who is to be the “leader” and who to be the “follower(s)” and communicate well with each other to ensure the safety of the workers.</li> <li>● When the product is under operation or in the ready mode, take the safety measures (such as the installation of safety and protection fence) so that nobody can enter the area within the robot’s movable range. When the robot under operation is touched, it may result in death or serious injury.</li> <li>● Make sure to install the emergency stop circuit so that the unit can be stopped immediately in an emergency during the unit operation.</li> <li>● Take the safety measure not to start up the unit only with the power turning ON. Failure to do so may start up the machine suddenly and cause an injury or damage to the product.</li> <li>● Take the safety measure not to start up the machine only with the emergency stop cancellation or recovery after the power failure. Failure to do so may result in an electric shock or injury due to unexpected power input.</li> <li>● When the installation or adjustment operation is to be performed, give clear warnings such as “Under Operation; Do not turn ON the power!” etc. Sudden power input may cause an electric shock or injury.</li> <li>● Take the measure so that the work part is not dropped in power failure or emergency stop.</li> <li>● Wear protection gloves, goggle or safety shoes, as necessary, to secure safety.</li> <li>● Do not insert a finger or object in the openings in the product. Failure to do so may cause an injury, electric shock, damage to the product or fire.</li> <li>● When releasing the brake on a vertically oriented actuator, exercise precaution not to pinch your hand or damage the work parts with the actuator dropped by gravity.</li> </ul>
5	Teaching	<ul style="list-style-type: none"> <li>● When the work is carried out with 2 or more persons, make it clear who is to be the “leader” and who to be the “follower(s)” and communicate well with each other to ensure the safety of the workers.</li> <li>● Perform the teaching operation from outside the safety protection fence, if possible. In the case that the operation is to be performed unavoidably inside the safety protection fence, prepare the “Stipulations for the Operation” and make sure that all the workers acknowledge and understand them well.</li> <li>● When the operation is to be performed inside the safety protection fence, the worker should have an emergency stop switch at hand with him so that the unit can be stopped any time in an emergency.</li> <li>● When the operation is to be performed inside the safety protection fence, in addition to the workers, arrange a watchman so that the machine can be stopped any time in an emergency. Also, keep watch on the operation so that any third person can not operate the switches carelessly.</li> <li>● Place a sign “Under Operation” at the position easy to see.</li> <li>● When releasing the brake on a vertically oriented actuator, exercise precaution not to pinch your hand or damage the work parts with the actuator dropped by gravity.</li> </ul> <p>* Safety protection Fence : In the case that there is no safety protection fence, the movable range should be indicated.</p>

No.	Operation Description	Description
6	Trial Operation	<ul style="list-style-type: none"> <li>● When the work is carried out with 2 or more persons, make it clear who is to be the “leader” and who to be the “follower(s)” and communicate well with each other to ensure the safety of the workers.</li> <li>● After the teaching or programming operation, perform the check operation one step by one step and then shift to the automatic operation.</li> <li>● When the check operation is to be performed inside the safety protection fence, perform the check operation using the previously specified work procedure like the teaching operation.</li> <li>● Make sure to perform the programmed operation check at the safety speed. Failure to do so may result in an accident due to unexpected motion caused by a program error, etc.</li> <li>● Do not touch the terminal block or any of the various setting switches in the power ON mode. Failure to do so may result in an electric shock or malfunction.</li> </ul>
7	Automatic Operation	<ul style="list-style-type: none"> <li>● Check before starting the automatic operation or rebooting after operation stop that there is nobody in the safety protection fence.</li> <li>● Before starting automatic operation, make sure that all peripheral equipment is in an automatic-operation-ready state and there is no alarm indication.</li> <li>● Make sure to operate automatic operation start from outside of the safety protection fence.</li> <li>● In the case that there is any abnormal heating, smoke, offensive smell, or abnormal noise in the product, immediately stop the machine and turn OFF the power switch. Failure to do so may result in a fire or damage to the product.</li> <li>● When a power failure occurs, turn OFF the power switch. Failure to do so may cause an injury or damage to the product, due to a sudden motion of the product in the recovery operation from the power failure.</li> </ul>

No.	Operation Description	Description
8	Maintenance and Inspection	<ul style="list-style-type: none"> <li>● When the work is carried out with 2 or more persons, make it clear who is to be the “leader” and who to be the “follower(s)” and communicate well with each other to ensure the safety of the workers.</li> <li>● Perform the work out of the safety protection fence, if possible. In the case that the operation is to be performed unavoidably inside the safety protection fence, prepare the “Stipulations for the Operation” and make sure that all the workers acknowledge and understand them well.</li> <li>● When the work is to be performed inside the safety protection fence, basically turn OFF the power switch.</li> <li>● When the operation is to be performed inside the safety protection fence, the worker should have an emergency stop switch at hand with him so that the unit can be stopped any time in an emergency.</li> <li>● When the operation is to be performed inside the safety protection fence, in addition to the workers, arrange a watchman so that the machine can be stopped any time in an emergency. Also, keep watch on the operation so that any third person can not operate the switches carelessly.</li> <li>● Place a sign “Under Operation” at the position easy to see.</li> <li>● For the grease for the guide or ball screw, use appropriate grease according to the instruction manual for each model.</li> <li>● Do not perform the dielectric strength test. Failure to do so may result in a damage to the product.</li> <li>● When releasing the brake on a vertically oriented actuator, exercise precaution not to pinch your hand or damage the work parts with the actuator dropped by gravity.</li> <li>● The slider or rod may get misaligned OFF the stop position if the servo is turned OFF. Be careful not to get injured or damaged due to an unnecessary operation.</li> <li>● Pay attention not to lose the removed cover or screws, and make sure to put the product back to the original condition after maintenance and inspection works. Use in incomplete condition may cause damage to the product or an injury.</li> </ul> <p style="text-align: center;">* Safety protection Fence : In the case that there is no safety protection fence, the movable range should be indicated.</p>
9	Modification and Dismantle	<ul style="list-style-type: none"> <li>● Do not modify, disassemble, assemble or use of maintenance parts not specified based at your own discretion.</li> </ul>
10	Disposal	<ul style="list-style-type: none"> <li>● When the product becomes no longer usable or necessary, dispose of it properly as an industrial waste.</li> <li>● When removing the actuator for disposal, pay attention to drop of components when detaching screws.</li> <li>● Do not put the product in a fire when disposing of it. The product may burst or generate toxic gases.</li> </ul>
11	Other	<ul style="list-style-type: none"> <li>● Do not come close to the product or the harnesses if you are a person who requires a support of medical devices such as a pacemaker. Doing so may affect the performance of your medical device.</li> <li>● See Overseas Specifications Compliance Manual to check whether complies if necessary.</li> <li>● For the handling of actuators and controllers, follow the dedicated instruction manual of each unit to ensure the safety.</li> </ul>

## Alert Indication

The safety precautions are divided into “Danger”, “Warning”, “Caution” and “Notice” according to the warning level, as follows, and described in the Operation Manual for each model.

Level	Degree of Danger and Damage	Symbol	
Danger	This indicates an imminently hazardous situation which, if the product is not handled correctly, will result in death or serious injury.		Danger
Warning	This indicates a potentially hazardous situation which, if the product is not handled correctly, could result in death or serious injury.		Warning
Caution	This indicates a potentially hazardous situation which, if the product is not handled correctly, may result in minor injury or property damage.		Caution
Notice	This indicates lower possibility for the injury, but should be kept to use this product properly.		Notice

## Caution in Handling

---

### 1. About Distribution Clock

Synchronizing control can not be accomplished because this product does not support the EtherCAT<sup>®</sup> Distribution Clock functionality.

## 1. Overview

EtherCAT<sup>®</sup>, an open field network, expands IEEE802.3 EtherNet Standards, and enables the high-speed and high-accuracy global open network.

You can connect XSEL-R\*/S\* controllers and TTA, MSEL to EtherCAT<sup>®</sup> to build a system with minimum wiring.

This instruction manual states the explanations for when using the EtherCAT<sup>®</sup> communication in XSEL-R\*/S\* and TTA, MSEL.

Refer to the following instruction manuals for explanations of other controllers.

Series	Operation Manual	Manual No.	Models
CON System (Single-Axis) Controllers	EtherCAT <sup>®</sup> Operation Manual	ME0273	ACON-C/CG/CA/CB/CGB DCON-CA/CB/CGB PCON-C/CG/CA/CFA/ CB/CFB/CGB/CGFB CBP/CGBP SCON-CA/CAL/CGAL/CB/CGB
MSEP	MSEP-C/LC Controller Operation Manual	ME0299	MSEP-C
MSCON	MSCON Controller Operation Manual	ME0306	MSCON-C
MCON	MCON-C/CG Controller Operation Manual	ME0341	MCON-C/CG
RCP6S Gateway	RCP6S Fieldbus Communication Operation Manual	ME0349	RCM-P6GW/P6GWG, RCM-P6PC/P6AC/P6DC
RCON	RCON System Operation Manual	ME0384	RCON-GW/GWG/LC/LCG
RSEL	RSEL System Operation Manual	ME0392	RSEL-G
REC	REC System Operation Manual	ME0394	REC-GW
RCON-NCN	RCON Gateway Unit Driver non-connection specification Operation Manual	ME0456	RCON-GWG-NCN

[System Configuration Example]

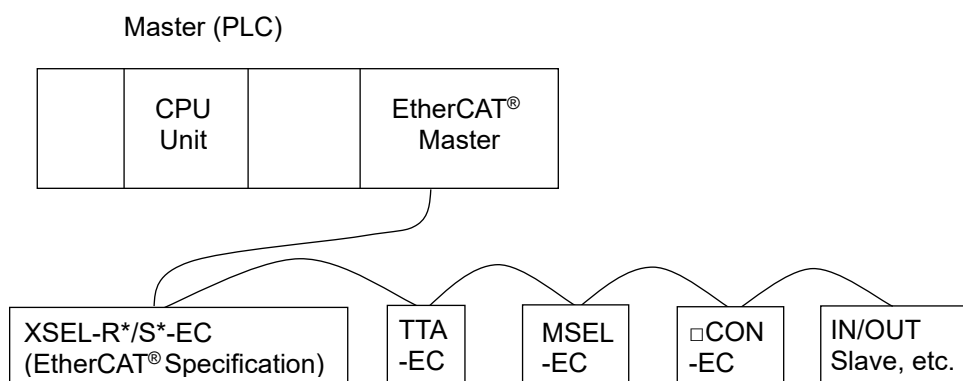

**Caution**

- Synchronizing control can not be accomplished because this product does not support the EtherCAT® Distribution Clock functionality.
- Only daisy chain network topology is supported.
- XSEL Controller and TTA is treated as an I/O device on EtherCAT®.
- For further information on EtherCAT®, refer to the Operation Manuals for the master unit and the programmable controller (PLC) to be mounted.
- Use this operation manual along with operation manual of each controller.
- Usage other than the ones described in this operation manual is prohibited.

## 2. EtherCAT® Specifications

Item	Description
Applicable Profile	CoE (CAN application protocol over EtherCAT)
Device Type	I/O Device
Node Address	0 to 65535 (Make setting from master)
Baud Rate	100Mbps
Communication Mode	100BASE-TX (Half-duplex)
Cable	Category 5e or more
Connector	RJ45×2

\* Synchronizing control can not be accomplished because this product does not support the EtherCAT® Distribution Clock functionality.

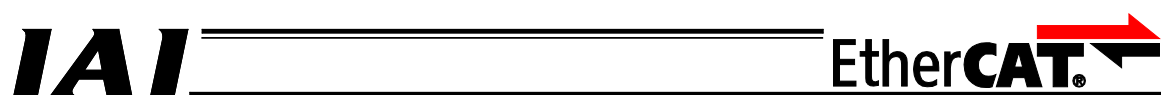

### 3. XSEL-R(A)/S(A)/R(A)X/S(A)X/R(A)XD/S(A)XD

#### 3.1 Operation Modes and Functions

XSEL Controllers applicable for EtherCAT® are applicable for the remote I/O control (\*1) (256 points max. for each input and output).

- \*1 I/O port is controlled in one port unit. I/O port is a point to receive and send data located inside the controller. 1 port can handle data of 1 contact (1 bit). Data are sent and received via either PIO (24V input and output) or field network. Connection to one port is available from only one of PIO or field network. Set a parameter to determine which of PIO or field network is to be used.

● Operation Image

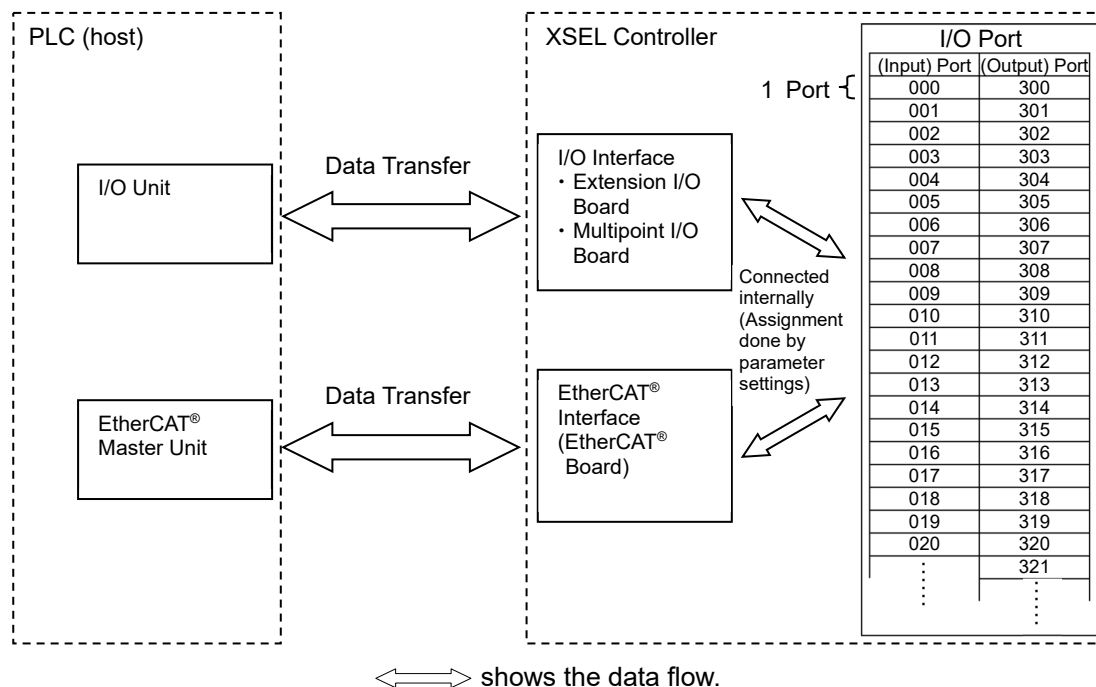

I/O Port	
(Input) Port	(Output) Port
000	300
001	301
002	302
003	303
004	304
005	305
006	306
007	307
008	308
009	309
010	310
011	311
012	312
013	313
014	314
015	315
016	316
017	317
018	318
019	319
020	320
⋮	321
⋮	⋮

3. XSEL-R(A)/S(A)/R(A)X/S(A)X/R(A)XD/S(A)XD

## 3.2 Model

The model code of each of XSEL-R(A)/S(A)/R(A)X/S(A)X/R(A)XD/S(A)XD applicable for EtherCAT® is as shown below.

### XSEL-R/S Series

- XSEL-R-□-EC-□
- XSEL-S-□-EC-□
- XSEL-RX-□-EC-□
- XSEL-SX-□-EC-□
- XSEL-RXD-□-EC-□
- XSEL-SXD-□-EC-□

### XSEL-RA/SA Series

- XSEL-RA-□-EC-□
- XSEL-SA-□-EC-□
- XSEL-RAX-□-EC-□
- XSEL-SAX-□-EC-□
- XSEL-RAXD-□-EC-□
- XSEL-SAXD-□-EC-□

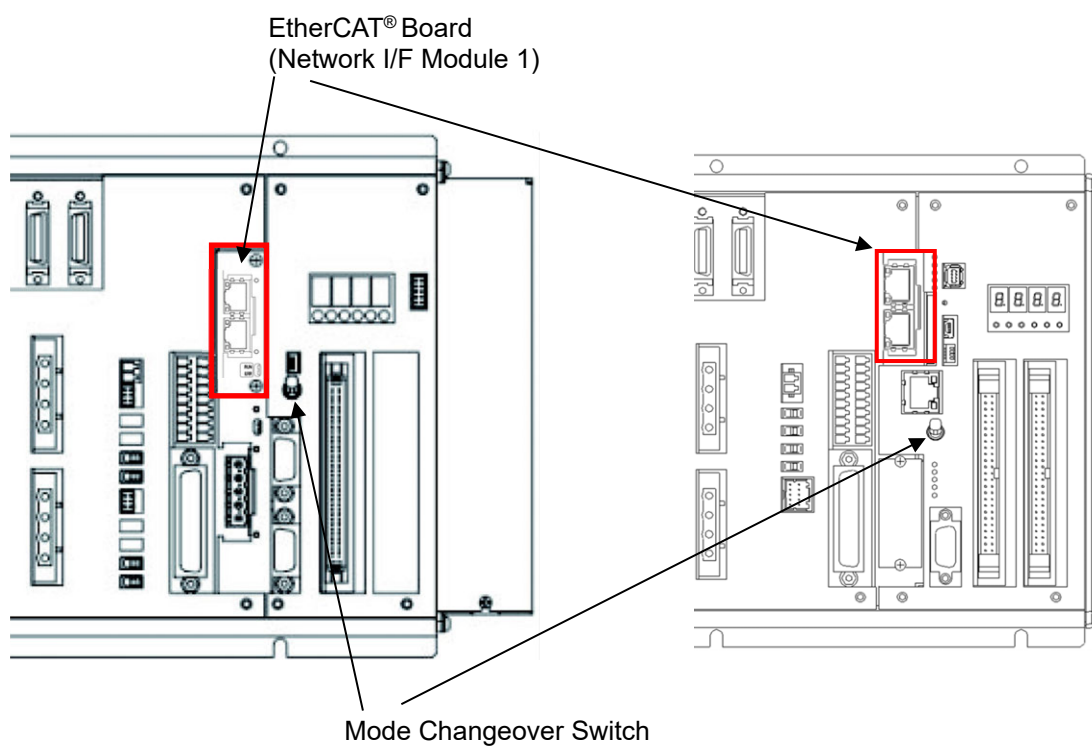

### 3.3 EtherCAT® Interface

#### 3.3.1 Names of the Parts

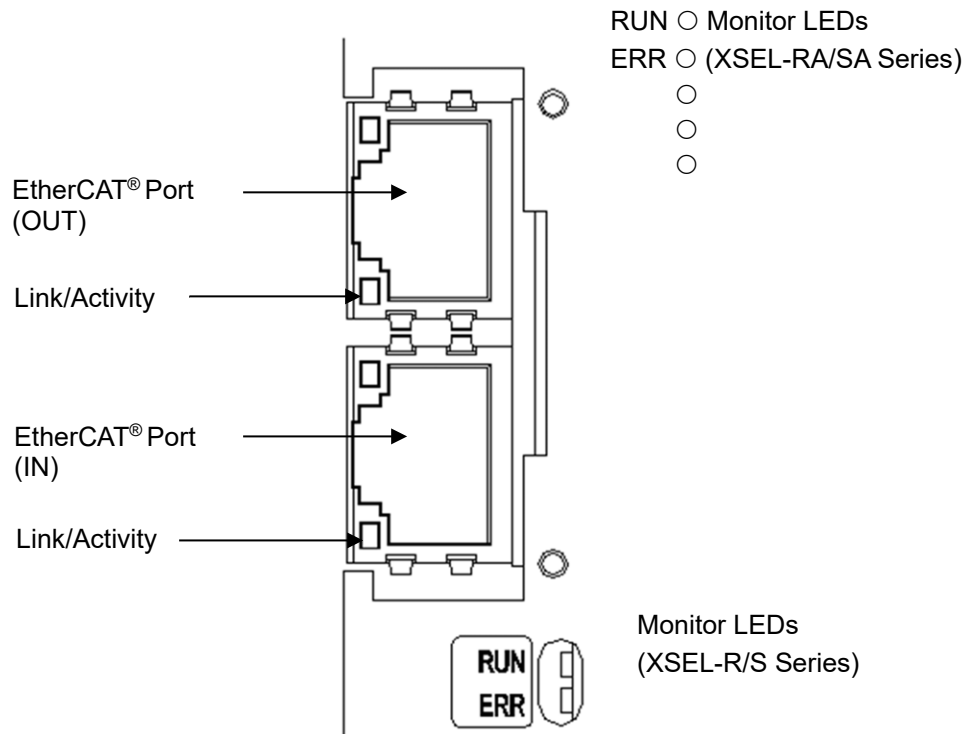

## 3.3.2 Monitor LED indications

LED	Color	Indication Status	Meaning
RUN	Green	Illuminating	Normal Communication Status. Both input and output are available for the process data. (EtherCAT® communication in "OPERATION" condition)
		Blinking *1	Under configuration condition in mailbox communication. Process data invalid. (EtherCAT® communication in "PRE-OPERATION" condition)
		Single flash *2	Configuration complete. Refer below for the process data communication. • Input : Inputting invalid • Output : Outputs 0 data (EtherCAT® communication in "SAFE-OPERATION" condition)
	Orange	Illuminating	An error that cannot be recovered (Module error)
	-	OFF	Initial condition (EtherCAT® communication in "INIT" condition) or the power is OFF
ERR	Orange	Illuminating	An error that cannot be recovered (Module error)
		Blinking *1	Network construction error
		Double flash *3	Communication error (Watchdog Timer Timeout)
	-	OFF	No abnormality or the power is OFF
Link/ Activity	Green	Illuminating	Linked (Communication traffic not detected)
		Flickering *4	Linked (Communication traffic detected)
	-	OFF	No link or the power is OFF

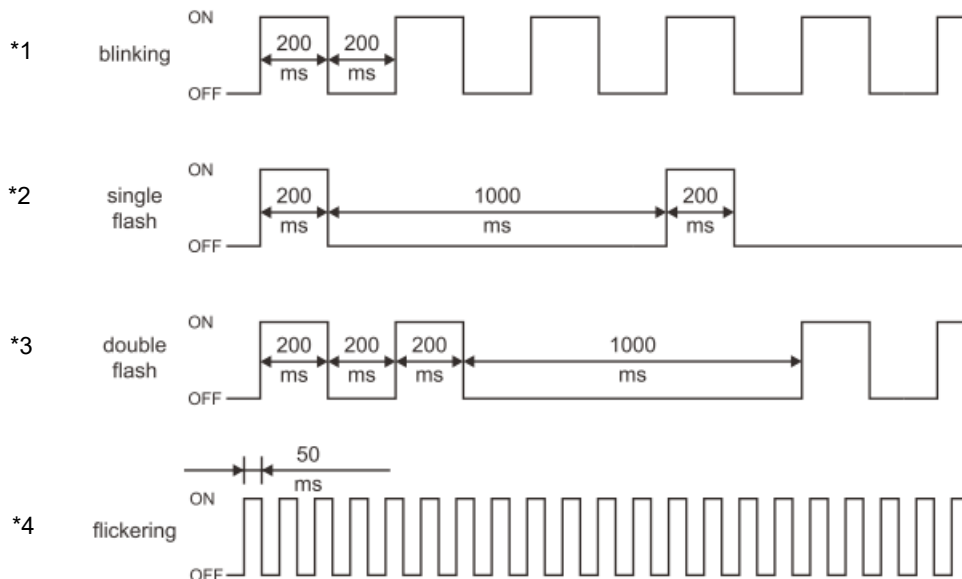

### 3.4 Wiring

#### 3.4.1 Wiring (example)

PLC (EtherCAT® Master Unit)

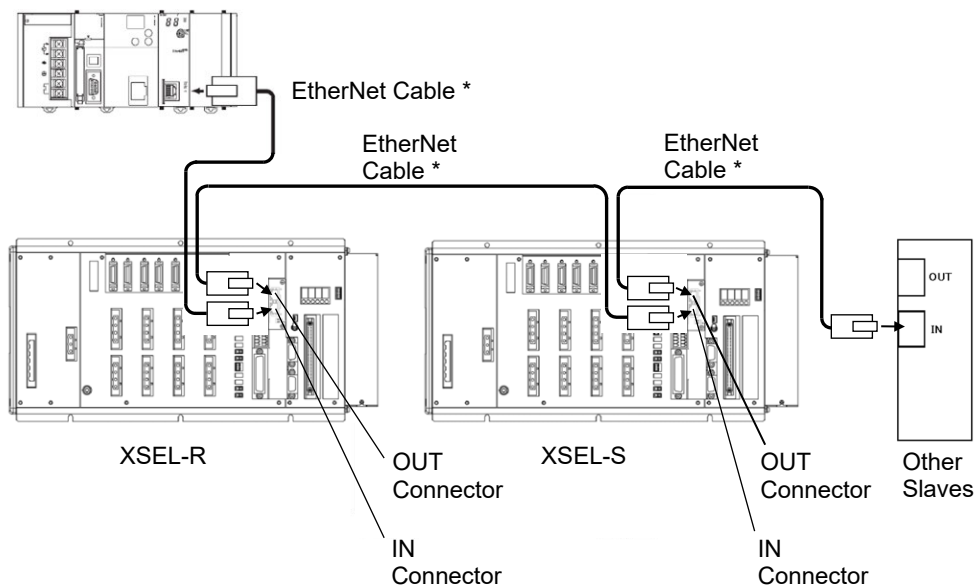

\* EtherNet Cable: Straight cable of category 5e or more, 100m max.  
(Aluminum tape and braided double-shielded cable are recommended.)

- Note 1 Only the daisy chain is supported in the network topology.
- Note 2 There are IN and OUT designated for the communication port for EtherCAT®.  
Be careful not to plug in the communication cable in the wrong way.
- Note 3 Terminal processing is not required.

#### 3.4.2 Connector Pin Layout

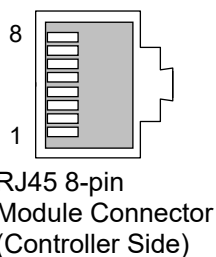

Pin No.	Signal Name	Signal Abbreviation
1	Data transmitted +	TD+
2	Data transmitted -	TD-
3	Data received +	RD+
4	Not used	
5	Not used	
6	Data received -	RD-
7	Not used	
8	Not used	
Connector Hood	Grounding pin for security	FG

## 3.5 Setting

Set to the I/O parameters in the controller by using a teaching tool.

Place the controller's AUTO/MANU switch in the MANU position.

The versions of teaching tool compatible with EtherCAT® please check the instruction manual of each teaching tool.

### 3.5.1 Parameter Setting

#### [1] Check of Network Module Type

- For XSEL-R/S Series

Confirm that the 1<sup>st</sup> digit of I/O Parameter No.225 Network I/F Module Control setting is showing "6" (EtherCAT®).

No.	Parameter name	Default (reference)	Input Range	Unit	Remarks
225	Network I/F Module Control	*6 Only to reference	0 <sub>H</sub> to FFFFFFF <sub>H</sub>	-	Bits 0 to 3 (First digit) : Network I/F Module 1 type 6: EtherCAT® 7: EtherNet/IP Bits 4 to 7 (2nd digit) : Network I/F Module 2 type 0: Not Mounted 1: CC-Link 2: DeviceNet 3: PROFIBUS-DP

The setting of this parameter is established at the delivery. For EtherCAT®, it is shown as "\*6h". The displayed values in the second digit and after (from Bit 4) may differ depending on the structure of the used option board.

- For XSEL-RA/SA Series

Confirm that the 1<sup>st</sup> digit of I/O Parameter No.225 Network I/F Module Control setting is showing "6" (EtherCAT®).

No.	Parameter name	Default (reference)	Input Range	Unit	Remarks
225	Network I/F Module Control	*06 Only to reference	0 <sub>H</sub> to FFFFFFF <sub>H</sub>	-	Bits 0 to 7 (1st and 2nd digits) : Network I/F Module 1 type 0: Not Mounted 6: EtherCAT® 7: EtherNet/IP Bits 8 to 15 (3rd and 4th digits) : Network I/F Module 2 type 0: Not Mounted 1: CC-Link 2: DeviceNet 3: PROFIBUS-DP 4 to C: System Reservation D: CC-Link IE Field

The setting of this parameter is established at the delivery. For EtherCAT®, it is shown as "\*06h".

The displayed values in the third digit and after (from Bit 8) may differ depending on the structure of the used option board.

## [2] Node Address Setting

Set the node address to I/O parameter No.226.

- When the node address allocation is automatically conducted from master : set to 0
- When the node address allocation is fixed : set to 1 to 65535

No.	Parameter name	Default (reference)	Input Range	Unit	Remarks
226	Network I/F Module 1 Node Address	0	0 to 99999999	-	0: Automatic Allocation Conducted from Master 1 to 65535: Fixed Allocation

“D75: Fieldbus Parameter Error” will occur when a value out of the settable range gets set.

## [3] Baud Rate Setting

It is unnecessary to establish the baud rate setting. It is fixed to 100BASE-TX (full-duplex).

## [4] I/O Port Assignment Classification Setting

Set the I/O port assignment Classification to I/O Parameter No.1.

No.	Parameter name	Default (reference)	Input Range	Unit	Remarks
1	I/O Port Allocation Type	0	0 to 1	-	0: Fixed Allocation 1: Automatic Allocation  • Reference 1 Priority of I/O Port Assignment when automatically assigned Port Number (No.0 to 299/No.300 to 599) 1) Network I/F Module1 2) I/O slot 1 (I/O1) Mounting board 3) I/O slot 2 (I/O2) Mounting board * I/O slot 1 (I/O1) Assigned for the continuously mounted range from mounting board  • Reference 2 Priority of extension I/O ports at automatic assignment Port Number (No.1000 to 3999/No.4000 to 6999) 1) Network I/F Module 2 2) Expansion I/O unit 3) IA Net * 2) and 3) are for XSEL-R/S Series only

**Note** If the automatic assignment is selected, the input port is assigned to an input port area (No. 0 to 299). The output port is assigned to the output port area (No. 300 to 599).  
If the fixed assignment is selected, the user will manually assign the input to either of the standard input port area (No. 0 to 299) or extension input port area (No. 1000 to 3999). For the output port, the user will manually assign the output to either the standard output port area (No. 300 to 599) or the extension output port area (No. 4000 to 6999).

## [5] Number of I/O Port Setting

Set the number of ports to be used for I/O Parameters No.14 to 15.

Set a number that is a multiple of 8.

No.	Parameter name	Default (reference)	Input Range	Unit	Remarks
14	Network I/F Module 1 Number of Remote Input Ports	256	0 to 256	-	Multiples of 8
15	Network I/F Module 1 Number of Remote Output Ports	256	0 to 256	-	Multiples of 8

## [6] I/O Port Top Number Setting

Set the top port number of the port range used in I/O Parameters No.16 to 17.  
The values entered into these parameters must be evenly divisible by 8.

No.	Parameter name	Default (reference)	Input Range	Unit	Remarks
16	Network I/F Module 1 Fix-Allocated Input Port Start No.	1000	-1 to 299, 1000 to 3999	-	0 + (Multiples of 8) (0 to 299) 1000 + (Multiples of 8) (1000 to 3999) (Unavailable when it is negative figure)
17	Network I/F Module 1 Fix-Allocated Output Port Start No.	4000	-1, 300 to 599, 4000 to 6999	-	300 + (Multiples of 8) (300 to 599) 4000 + (Multiples of 8) (4000 to 6999) (Unavailable when it is negative figure)

## [7] EtherCAT® Board Use Setting

Set "1" (Monitoring: use EtherCAT® board) to I/O Parameter No.18.

No.	Parameter name	Default (reference)	Input Range	Unit	Remarks
18	Network I/F Module 1 Error Monitor	1	0 to 5	-	0: No Monitoring (Not to use EtherCAT® board) 1: Monitoring (use EtherCAT® board)

## [8] Time Setting to Wait for EtherCAT® Communication Establishment

Set the maximum allowable time for the establishment of EtherCAT® communication at the startup in bits 16 to 27 of I/O Parameter No.121. Change this setting when XSEL starts faster than the master unit, which results in a generation of "D5D" or "A6B".

No.	Parameter name	Default (reference)	Input Range	Unit	Remarks
121	Network Attribute 2	C80000 <sub>H</sub>	0 <sub>H</sub> to FFFFFFF <sub>H</sub>	100 ms	Bits 16 to 27: Value of Link Timeout at initializing of the Fieldbus (Example) The initial value C80000H is bit 16 to 27 = C8H = 200 (in 100ms unit) 200×100ms = 20sec Check in 20sec after startup

## [9] Data Retaining Setting at EtherCAT® Communication Error

Set whether to clear the input port data with 0 or to retain when an error is generated in bits 28 to 31 of I/O Parameter No.120.

No.	Parameter name	Default (reference)	Input Range	Unit	Remarks
120	Network Attribute 1	640001 <sub>H</sub>	0 <sub>H</sub> to FFFFFFF <sub>H</sub>		Bit 28 to 31: Network I/F Module 1 Input port data select for link error (0: Clear, 1: Hold)

## 3.5.2 Example for Parameter Settings

### (1) Example for when using only EtherCAT®

It is how to establish the setting when using EtherCAT® to 16 ports of each input and output from the top of the standard I/O ports, and no other I/O port (for I/O board, etc.) is to be used.

\* The figure shown below is XSEL-R/S series. The setting should be the same for XSEL-RA/SA series.

(Except for I/O Parameter No. 225)

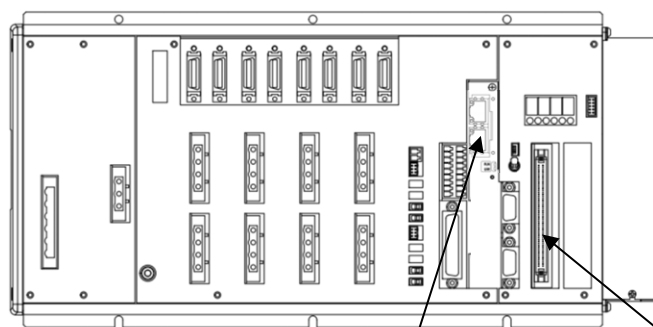

Standard Input Port No.0 to 15  
Standard Output Port No.300 to 315  
(EtherCAT® Board)  
Related Parameters No.14 to 18

Not to be used  
(I/O Board)  
Related Parameters No.2, 3, 10

### • I/O Parameter

No.	Parameter name	Default (reference)	Input Range	Unit	Remarks
1	I/O Port Allocation Type	0	0 to 1	0	0:Fixed Allocation 1:Automatic Allocation  • Reference 1 Priority of I/O Port Assignment when automatically assigned Port Number (No.0 to 299/No.300 to 599) 1) Network I/F Module 1 2) I/O slot 1 (I/O1) Mounting board 3) I/O slot 2 (I/O2) Mounting board * I/O slot 1 (I/O1) Assigned for the continuously mounted range from mounting board  • Reference 2 Priority of extension I/O ports at automatic assignment Port Number (No.1000 to 3999/No.4000 to 6999) 1) Network I/F Module 2 2) Expansion I/O unit 3) IA Net * 2) and 3) are for XSEL-R/S Series only
2	Standard I/O Fix-Allocated Input Port Start No.	0	-1 to 299	-1	0 + (Multiples of 8) [Ineffective when -1 is selected]
3	Standard I/O Fix-Allocated Output Port Start No.	300	-1 300 to 599	-1	300 + (Multiples of 8) [Ineffective when -1 is selected]

No.	Parameter name	Default (reference)	Input Range	Unit	Remarks
10	Standard I/O Error Monitoring (I/O1)	1	0 to 5	0	0: No Monitoring (Not to use I/O board) 1: Monitoring 2: Monitoring (Not to monitor 24V I/O power related error) 3: Monitoring (To monitor only 24V I/O power related error) 4: Monitoring (24V I/O power related error as well as message level)
14	Network I/F Module 1 Number of Remote Input Ports	256	0 to 256	16	Multiples of 8
15	Network I/F Module 1 Number of Remote Output Ports	256	0 to 256	16	Multiples of 8
16	Network I/F Module 1 Fix-Allocated Input Port Start No.	1000	-1 to 299 1000 to 3999	0	0 + (Multiples of 8) (0 to 299) 1000 + (Multiples of 8) (1000 to 3999) [Unavailable when it is negative figure]
17	Network I/F Module 1 Fix-Allocated Output Port Start No.	4000	-1 300 to 599 4000 to 6999	300	300 + (Multiples of 8) (300 to 599) 4000 + (Multiples of 8) (4000 to 6999) [Unavailable when it is negative figure]
18	Network I/F Module 1 Error Monitor	1	0 to 5	1	0: No Monitoring (Not to use Network I/F Module 1) 1: Monitoring
120	Network Attribute 1	640001 <sub>H</sub>	0 <sub>H</sub> to FFFFFFFF <sub>H</sub>	Optional	Bit 28 to 31: Network I/F Module 1 Input port data select for link error (0: Clear, 1: Hold)
121	Network Attribute 2	C80000 <sub>H</sub>	0 <sub>H</sub> to FFFFFFFF <sub>H</sub>	Optional	Bits 8 to 11: Network I/F Module 2 Input port data select for link error (0: Clear, 1: Hold) Bits 16 to 27: Value of Link Timeout at initializing of the Fieldbus (100ms)
225	Network I/F Module Control  Those stated in brackets ( ) are for XSEL-RA/SA Series	*6 (*06)	00 <sub>H</sub> to 37 <sub>H</sub> (000 <sub>H</sub> to 307 <sub>H</sub> ) Reference only	06 (006)	Bits 0 to 3: (Bits 0 to 7:) Network I/F Module 1 type 0: Not Mounted 6: EtherCAT® 7: EtherNet/IP Bits 4 to 7: (Bits 8 to 15:) Network I/F Module 2 type 0: Not Mounted 1: CC-Link 2: DeviceNet 3: PROFIBUS 4 to C: System Reservation D: CC-Link IE Field (XSEL-RA/SA only)
226	Network I/F Module 1 Node Address	0	0 to 65535	0	0: Make setting from master 1 to 65535: Fixed Allocation
231	Network I/F Module 2 Number of Remote Input Ports	0	0 to 256	0	Multiples of 8
232	Network I/F Module 2 Number of Remote Output Ports	0	0 to 256	0	Multiples of 8
233	(Extension) <sup>(Note 1)</sup> Input Port Start No. at Network I/F Module 2 Fixed Assignment	-1	-1 to 299 1000 to 3999	-1	0 + (Multiples of 8) or 1000+(Multiples of 8) [Ineffective when -1 is selected]
234	(Extension) <sup>(Note 1)</sup> Output Port Start No. at Network I/F Module 2 Fixed Assignment	-1	-1 300 to 599 4000 to 6999	-1	300 + (Multiples of 8) or 4000 + (Multiples of 8) [Ineffective when -1 is selected]
235	Network I/F Module 2 Error Monitoring	1	0 to 5	0	0: No Monitoring (Not to monitor condition of link to PLC (master)) 1: Monitoring

Note 1: The commands with "Extended" in the parameter name should only be applied for XSEL-R/S.

- (2) Example for when using EtherCAT® and I/O Board 1 together  
 It is how to establish the setting when using EtherCAT® to 256 ports of each input and output from the top of the extended I/O ports and assigning the I/O board (48 ports for each input and output) to the standard I/O ports.

\* The figure shown below is XSEL-R/S series. The setting should be the same for XSEL-RA/SA series.

(Except for I/O Parameter No. 225)

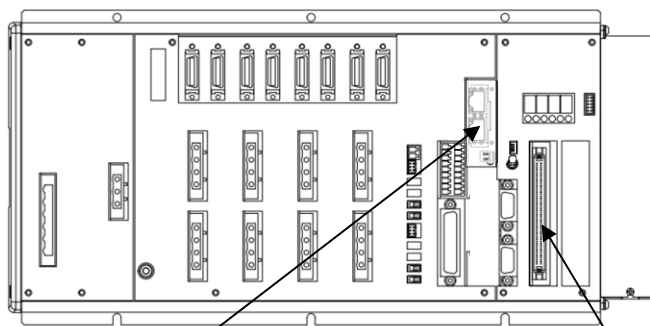

Extended Input Ports No.1000 to 1255  
 Extended Output Ports No.4000 to 4255  
 (EtherCAT® Board)  
 Related Parameters No.14 to 18

Standard Input Port No.0 to 47  
 Standard Output Port No.300 to 347  
 (I/O Board)  
 Related Parameters No.2, 3, 10

• I/O Parameter

No.	Parameter name	Default (reference)	Input Range	Unit	Remarks
1	I/O Port Allocation Type	0	0 to 1	0	0:Fixed Allocation 1:Automatic Allocation  • Reference 1 Priority of I/O Port Assignment when automatically assigned Port Number (No.0 to 299/No.300 to 599) 1) Network I/F Module 1 2) I/O slot 1 (I/O1) Mounting board 3) I/O slot 2 (I/O2) Mounting board * I/O slot 1 (I/O1) Assigned for the continuously mounted range from mounting board  • Reference 2 Priority of extension I/O ports at automatic assignment Port Number (No.1000 to 3999/No.4000 to 6999) 1) Network I/F Module 2 2) Expansion I/O unit 3) IA Net * 2) and 3) are for XSEL-R/S Series only
2	Standard I/O Fix-Allocated Input Port Start No.	0	-1 to 299	0	0 + (Multiples of 8) [Ineffective when -1 is selected]
3	Standard I/O Fix-Allocated Output Port Start No.	300	-1 300 to 599	300	300 + (Multiples of 8) [Ineffective when -1 is selected]
10	Standard I/O Error Monitoring (I/O1)	1	0 to 5	1	0: No Monitoring (Not to use I/O board) 1: Monitoring 2: Monitoring (Not to monitor 24V I/O power related error) 3: Monitoring (To monitor only 24V I/O power related error) 4: Monitoring (24V I/O power related error as well as message level)
14	Network I/F Module 1 Number of Remote Input Ports	256	0 to 256	256	Multiples of 8

No.	Parameter name	Default (reference)	Input Range	Unit	Remarks
15	Network I/F Module 1 Number of Remote Output Ports	256	0 to 256	256	Multiples of 8
16	Network I/F Module 1 Fix-Allocated Input Port Start No.	1000	-1 to 299 1000 to 3999	1000	0 + (Multiples of 8) (0 to 299) 1000 + (Multiples of 8) (1000 to 3999) [Unavailable when it is negative figure]
17	Network I/F Module 1 Fix-Allocated Output Port Start No.	4000	-1 300 to 599 4000 to 6999	4000	300 + (Multiples of 8) (300 to 599) 4000 + (Multiples of 8) (4000 to 6999) [Unavailable when it is negative figure]
18	Network I/F Module 1 Error Monitor	1	0 to 5	1	0: No Monitoring (Not to use Network I/F Module 1) 1: Monitoring
120	Network Attribute 1	640001 <sub>H</sub>	0 <sub>H</sub> to FFFFFFFF <sub>H</sub>	Optional	Bits 28 to 31: Network I/F Module 1 Input port data select for link error (0: Clear, 1: Hold)
121	Network Attribute 2	C80000 <sub>H</sub>	0 <sub>H</sub> to FFFFFFFF <sub>H</sub>	Optional	Bits 8 to 11: Network I/F Module 2 Input port data select for link error (0: Clear, 1: Hold) Bits 16 to 27: Value of Link Timeout at initializing of the Fieldbus (100ms)
225	Network I/F Module Control  Those stated in brackets ( ) are for XSEL-RA/SA Series	*6 (*06)	00 <sub>H</sub> to 37 <sub>H</sub> (000 <sub>H</sub> to 307 <sub>H</sub> ) Reference only	06 (006)	Bits 0 to 3: (Bits 0 to 7:) Network I/F Module 1 type 0: Not Mounted 6: EtherCAT® 7: EtherNet/IP Bits 4 to 7: (Bits 8 to 15:) Network I/F Module 2 type 0: Not Mounted 1: CC-Link 2: DeviceNet 3: PROFIBUS 4 to C: System Reservation D: CC-Link IE Field (XSEL-RA/SA only)
226	Network I/F Module 1 Node Address	0	0 to 65535	0	0: Make setting from master 1 to 65535: Fixed Allocation
231	Network I/F Module 2 Number of Remote Input Ports	0	0 to 256	0	Multiples of 8
232	Network I/F Module 2 Number of Remote Output Ports	0	0 to 256	0	Multiples of 8
233	(Extension) <sup>(Note 1)</sup> Input Port Start No. at Network I/F Module 2 Fixed Assignment	-1	-1 to 299 1000 to 3999	-1	0 + (Multiples of 8) or 1000+(Multiples of 8) [Ineffective when -1 is selected]
234	(Extension) <sup>(Note 1)</sup> Output Port Start No. at Network I/F Module 2 Fixed Assignment	-1	-1 300 to 599 4000 to 6999	-1	300 + (Multiples of 8) or 4000+(Multiples of 8) [Ineffective when -1 is selected]
235	Network I/F Module 2 Error Monitoring	1	0 to 5	0	0: No Monitoring (Not to monitor condition of link to PLC (master)) 1: Monitoring

Note 1: The commands with "Extended" in the parameter name should only be applied for XSEL-R/S.

(3) Example for when using EtherCAT® and I/O Board 1 together

This is the setting of when using 192 points of each input and output from the top of the standard I/O ports in EtherCAT®, and also sharing the standard I/O ports with the I/O board (48 points of each input and output).

\* The figure shown below is XSEL-R/S series. The setting should be the same for XSEL-RA/SA series.

(Except for I/O Parameter No. 225)

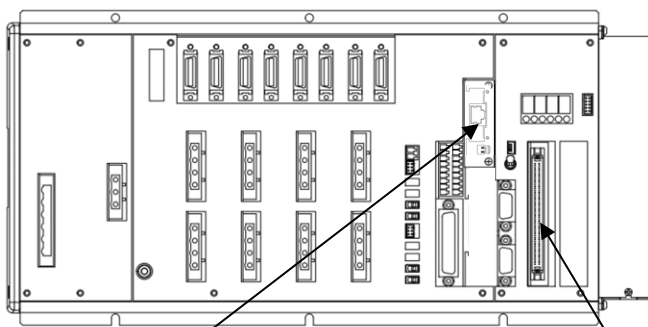

Standard Input Port No.0 to 191  
Standard Output Port No.300 to 491  
(EtherCAT® Board)  
Related Parameters No.14 to 18

Standard Input Port No.192 to 239  
Standard Output Port No.492 to 539  
(I/O Board)  
Related Parameters No.2, 3, 10

● I/O Parameter

No.	Parameter name	Default (reference)	Input Range	Unit	Remarks
1	I/O Port Allocation Type	0	0 to 1	0	0:Fixed Allocation 1:Automatic Allocation  • Reference 1 Priority of I/O Port Assignment when automatically assigned Port Number (No.0 to 299/No.300 to 599) 1) Network I/F Module 1 2) I/O slot 1 (I/O1) Mounting board 3) I/O slot 2 (I/O2) Mounting board * I/O slot 1 (I/O1) Assigned for the continuously mounted range from mounting board  • Reference 2 Priority of extension I/O ports at automatic assignment Port Number (No.1000 to 3999/No.4000 to 6999) 1) Network I/F Module 2 2) Expansion I/O unit 3) IA Net * 2) and 3) are for XSEL-R/S Series only
2	Standard I/O Fix-Allocated Input Port Start No.	0	-1 to 299	192	0 + (Multiples of 8) [Ineffective when -1 is selected]
3	Standard I/O Fix-Allocated Output Port Start No.	300	-1 300 to 599	492	300 + (Multiples of 8) [Ineffective when -1 is selected]
10	Standard I/O Error Monitoring (I/O1)	1	0 to 5	1	0: No Monitoring (Not to use I/O board) 1: Monitoring 2: Monitoring (Not to monitor 24V I/O power related error) 3: Monitoring (To monitor only 24V I/O power related error) 4: Monitoring (24V I/O power related error as well as message level)
14	Network I/F Module 1 Number of Remote Input Ports	256	0 to 256	192	Multiples of 8

No.	Parameter name	Default (reference)	Input Range	Unit	Remarks
15	Network I/F Module 1 Number of Remote Output Ports	256	0 to 256	192	Multiples of 8
16	Network I/F Module 1 Fix-Allocated Input Port Start No.	1000	-1 to 299 1000 to 3999	0	0 + (Multiples of 8) (0 to 299) 1000 + (Multiples of 8) (1000 to 3999) [Unavailable when it is negative figure]
17	Network I/F Module 1 Fix-Allocated Output Port Start No.	4000	-1 300 to 599 4000 to 6999	300	300 + (Multiples of 8) (300 to 599) 4000 + (Multiples of 8) (4000 to 6999) [Unavailable when it is negative figure]
18	Network I/F Module 1 Error Monitor	1	0 to 5	1	0: No Monitoring (Not to use Network I/F Module 1) 1: Monitoring
120	Network Attribute 1	640001 <sub>H</sub>	0 <sub>H</sub> to FFFFFFFF <sub>H</sub>	Optional	Bits 28 to 31: Network I/F Module 1 Input port data select for link error (0: Clear, 1: Hold)
121	Network Attribute 2	C80000 <sub>H</sub>	0 <sub>H</sub> to FFFFFFFF <sub>H</sub>	Optional	Bits 8 to 11: Network I/F Module 2 Input port data select for link error (0: Clear, 1: Hold) Bits 16 to 27: Value of Link Timeout at initializing of the Fieldbus (100ms)
225	Network I/F Module Control  Those stated in brackets ( ) are for XSEL-RA/SA Series	*6 (*06)	00 <sub>H</sub> to 37 <sub>H</sub> (000 <sub>H</sub> to 307 <sub>H</sub> ) Reference only	06 (006)	Bits 0 to 3: (Bits 0 to 7:) Network I/F Module 1 type 0: Not Mounted 6: EtherCAT® 7: EtherNet/IP Bits 4 to 7: (Bits 8 to 15:) Network I/F Module 2 type 0: Not Mounted 1: CC-Link 2: DeviceNet 3: PROFIBUS 4 to C: System Reservation D: CC-Link IE Field (XSEL-RA/SA only)
226	Network I/F Module 1 Node Address	0	0 to 65535	0	0: Make setting from master 1 to 65535: Fixed Allocation
231	Network I/F Module 2 Number of Remote Input Ports	0	0 to 256	0	Multiples of 8
232	Network I/F Module 2 Number of Remote Output Ports	0	0 to 256	0	Multiples of 8
233	(Extension) <sup>(Note 1)</sup> Input Port Start No. at Network I/F Module 2 Fixed Assignment	-1	-1 to 299 1000 to 3999	-1	0 + (Multiples of 8) or 1000 + (Multiples of 8) [Ineffective when -1 is selected]
234	(Extension) <sup>(Note 1)</sup> Output Port Start No. at Network I/F Module 2 Fixed Assignment	-1	-1 300 to 599 4000 to 6999	-1	300 + (Multiples of 8) or 4000 + (Multiples of 8) [Ineffective when -1 is selected]
235	Network I/F Module 2 Error Monitoring	1	0 to 5	0	0: No Monitoring (Not to monitor condition of link to PLC (master)) 1: Monitoring

Note 1: The commands with "Extended" in the parameter name should only be applied for XSEL-R/S.

### 3.6 Standard I/O Ports of XSEL Controller

It is available to add special functions beside the general-purposed input and output in the standard I/O ports of XSEL Controllers.

[Refer to XSEL-R/S/RX/SX/RXD/SXD Controller or XSEL-RA/SA/RAX/SAX/RAXD/SAXD controller Operation Manual for the details.]

[Settings of Standard I/O Ports at Delivery]

Input Port		Output Port	
Port No.	Function	Port No.	Function
000	Program Start	300	Alarm Output
001	Universal Input	301	Ready Output
002	Universal Input	302	Emergency Stop Output
003	Universal Input	303	Universal Output
004	Universal Input	304	Universal Output
005	Universal Input	305	Universal Output
006	Universal Input	306	Universal Output
007	Program Specification	307	Universal Output
008	Program Specification	308	Universal Output
009	Program Specification	309	Universal Output
010	Program Specification	310	Universal Output
011	Program Specification	311	Universal Output
012	Program Specification	312	Universal Output
013	Program Specification	313	Universal Output
014	Universal Input	314	Universal Output
015	Universal Input	315	Universal Output
	⋮		⋮

(Note) Number of standard I/O ports is:

- Input 000 to 299 (300 points max.)
- Output 300 to 599 (300 points max.)

Be careful of the number of I/O ports when using EtherCAT® and PIO together.

### 3.7 I/O Port and Data Reading and Writing

The initial setting of SEL language commands for the operation of I/O (input and output) ports of XSEL Controller is set to execute reading and writing without the data being exchanged. Shown below is an example for the assignments on the EtherCAT® master side and XSEL controller side.

[XSEL side output domain ⇒ EtherCAT® master side input domain]

Address	Bit 7 (MSB)	6	5	4	3	2	1	0 (LSB)
XSEL Output Port Number	307	306	305	304	303	302	301	300
EtherCAT® Input word address	0 (lower-order byte)							
XSEL Output Port Number	315	314	313	312	311	310	309	308
EtherCAT® Input word address	0 (host byte)							
XSEL Output Port Number	323	322	321	320	319	318	317	316
EtherCAT® Input word address	1 (lower-order byte)							
XSEL Output Port Number	331	330	329	328	327	326	325	324
EtherCAT® Input word address	1 (host byte)							

⋮

- Example Data (1234h) from XSEL is changed to 1234h in EtherCAT®.

XSEL	HEX	1	2	3	4
	BIN	0001	0010	0011	0100

↓ ↓

Ether CAT® Master	HEX	1	2	3	4
	BIN	0001	0010	0011	0100

[EtherCAT® master side output domain ⇒ XSEL side input domain]

Address	Bit 7 (MSB)	6	5	4	3	2	1	0 (LSB)
XSEL Input Port Number	7	6	5	4	3	2	1	0
EtherCAT® Output word address	0 (lower-order byte)							
XSEL Input Port Number	15	14	13	12	11	10	9	8
EtherCAT® Output word address	0 (host byte)							
XSEL Input Port Number	23	22	21	20	19	18	17	16
EtherCAT® Output word address	1 (lower-order byte)							
XSEL Input Port Number	31	30	29	28	27	26	25	24
EtherCAT® Output word address	1 (host byte)							

⋮

- Example Data (1234h) from EtherCAT® master is changed to 1234h in XSEL.

EtherCAT® Master	HEX	1	2	3	4
	BIN	0001	0010	0011	0100

↓ ↓

XSEL	HEX	1	2	3	4
	BIN	0001	0010	0011	0100

●Reference How to Read and Write with Swapping Host 8 Bits with Lower 8 Bits for Every 16-Bit Data

When conducting reading and writing with swapping the host 8 bits with lower 8 bits for every 16-bit data, set Format Type to 1 (Swap host 8 bits with lower 8 bits for every 16-bit data) with FMIO Command before executing an input and output port operation command such as IN Command and OUT Command in XSEL Controller.

[Refer to XSEL Controller Operation Manual.]

Shown below is an example for the assignments on EtherCAT® master side and XSEL controller side.

[EtherCAT® master side output domain ⇒ XSEL side input domain]

Address	Bit 7 (MSB)	6	5	4	3	2	1	0 (LSB)
XSEL Input Port Number	307	306	305	304	303	302	301	300
EtherCAT® Output bit address	15	14	13	12	11	10	9	8
EtherCAT® Output word address	0 (host byte)							
XSEL Input Port Number	315	314	313	312	311	310	309	308
EtherCAT® Output bit address	7	6	5	4	3	2	1	0
EtherCAT® Output word address	0 (lower-order byte)							
XSEL Input Port Number	323	322	321	320	319	318	317	316
EtherCAT® Output bit address	31	30	29	28	27	26	25	24
EtherCAT® Output word address	1 (host byte)							
XSEL Input Port Number	331	330	329	328	327	326	325	324
EtherCAT® Output bit address	23	22	21	20	19	18	17	16
EtherCAT® Output word address	1 (lower-order byte)							

⋮

● Example Data (1234h) from EtherCAT® master is changed to 3412h in XSEL.

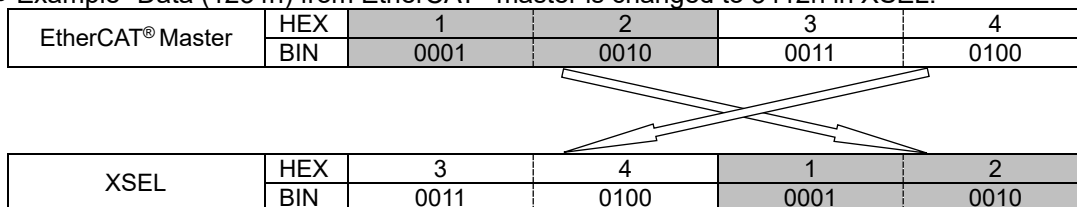



## 4. Table-top Robot TTA

### 4.1 Operation Modes and Functions

Table-top Robot (TTA) applicable for EtherCAT® are applicable for the remote I/O control (\*1) (240 points max. for each input and output).

- \*1 I/O port is controlled in one port unit. I/O port is a point to receive and send data located inside the TTA. 1 port can handle data of 1 contact (1 bit). Data are sent and received via either PIO (24V input and output) or field network. Connection to one port is available from only one of PIO or field network. Set a parameter to determine which of PIO or field network is to be used.

● Operation Image

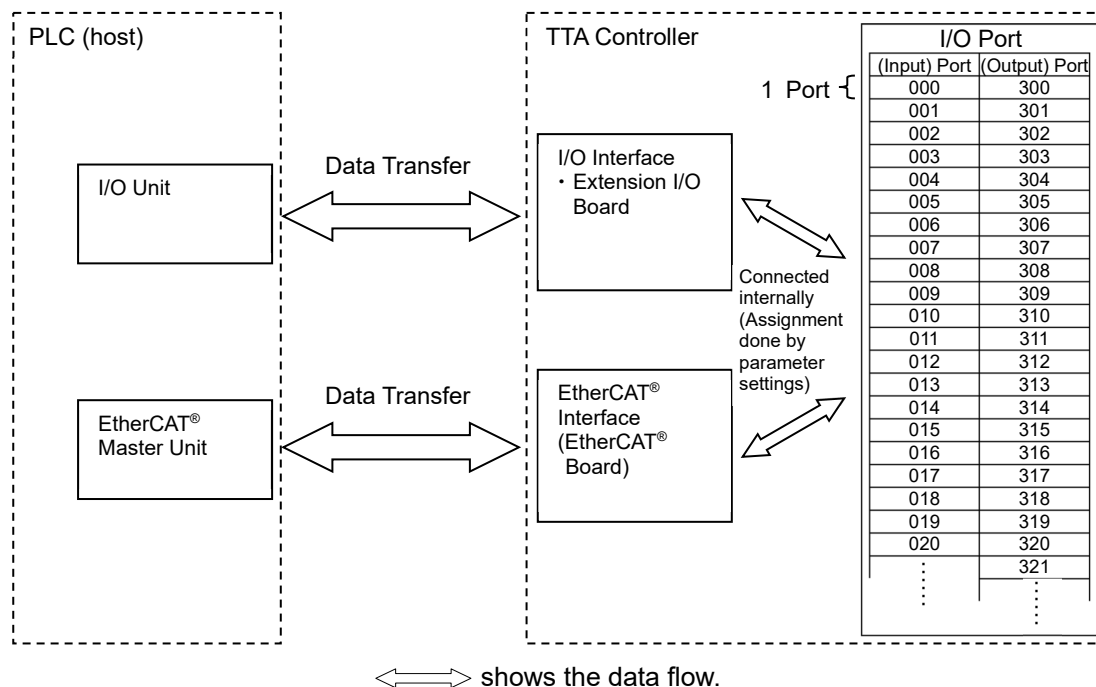

4.2 Model

The model code of each of TTA applicable for EtherCAT® is as shown below.

- TTA-A□(SL/SH) (G)-WA-□-□-□-□-EC
- TTA-C□(SL/SH) (G)-WA-□-□-□-□-EC
- TTA-A□(SL/SH) (G)-WA-□-□-□-□-□-EC
- TTA-C□(SL/SH) (G)-WA-□-□-□-□-□-EC
- TTA-A□(SL/SH) (G)-WA-□-□-□-□-EC-EC
- TTA-C□(SL/SH) (G)-WA-□-□-□-□-EC-EC

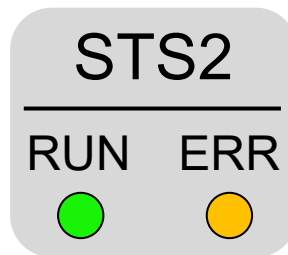

4. Table-top Robot TTA

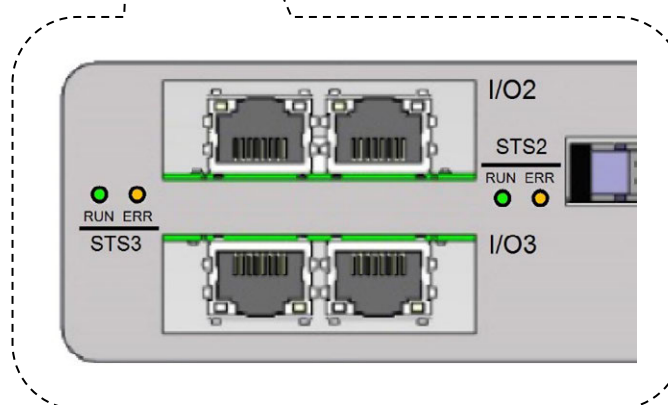
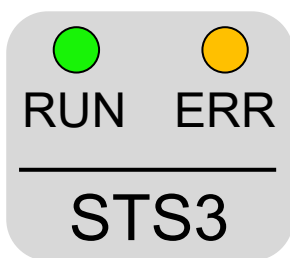
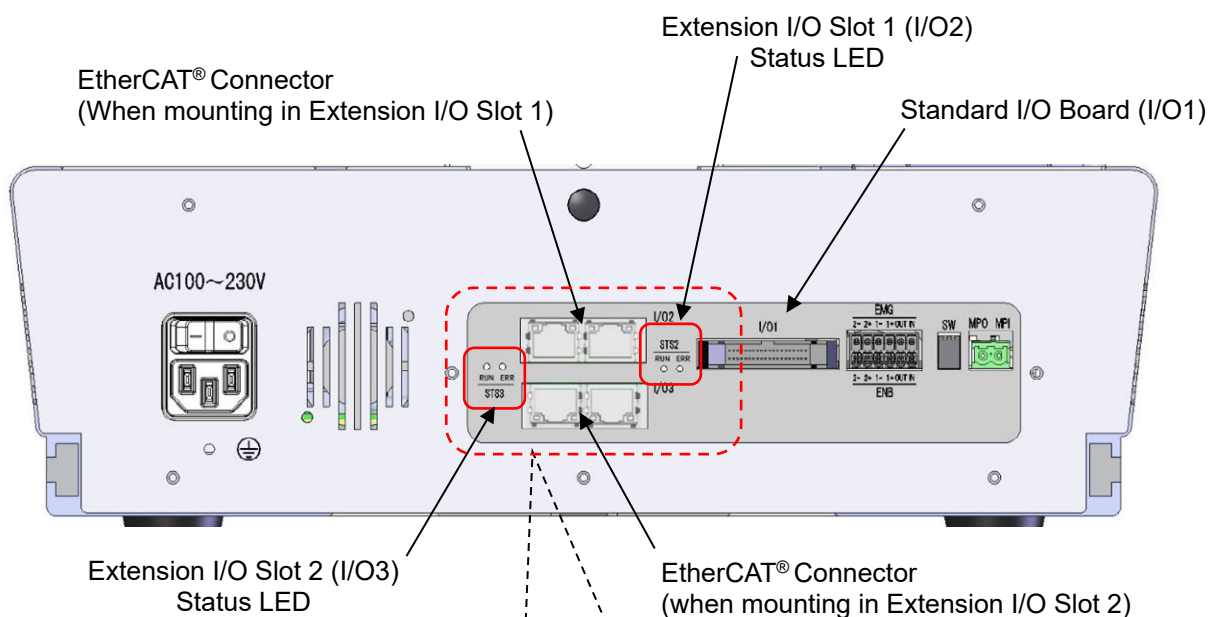

4.3 EtherCAT® Interface

4.3.1 Names of the Parts

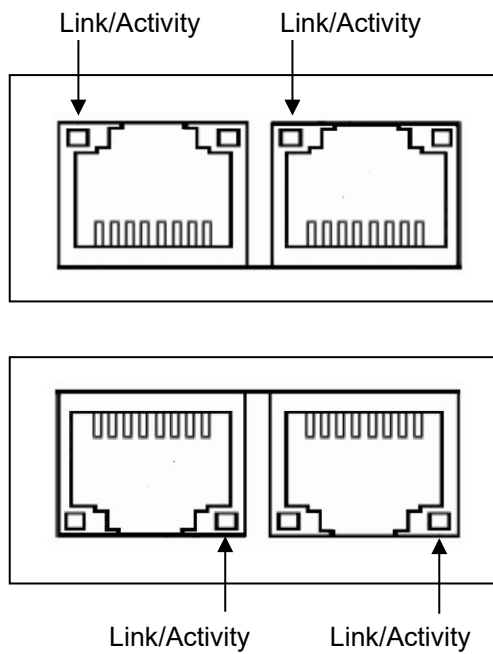
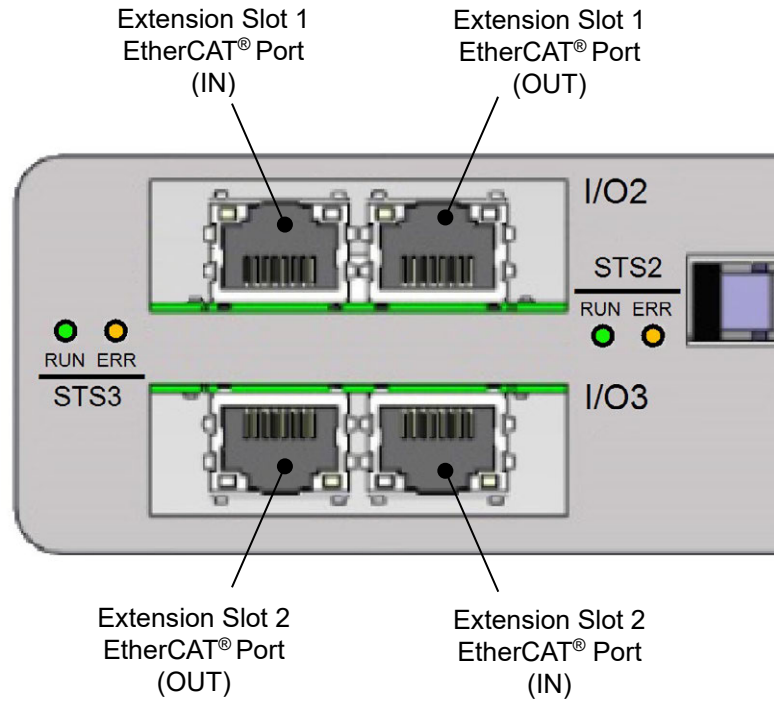

## 4.3.2 Monitor LED indications

LED	Color	Indication Status	Meaning
RUN	Green	Illuminating	Normal Communication Status. Both input and output are available for the process data. (EtherCAT® communication in "OPERATION" condition)
		Blinking *1	Under configuration condition in mailbox communication. Process data invalid. (EtherCAT® communication in "PRE-OPERATION" condition)
		Single flash *2	Configuration complete. Refer below for the process data communication. • Input : Inputting invalid • Outut: Outputs 0 data (EtherCAT® communication in "SAFE-OPERATION" condition)
	Orange	Illuminating	An error that cannot be recovered (Module error)
	-	OFF	Initial condition (EtherCAT® communication in "INIT" condition) or the power is OFF
ERR	Orange	Illuminating	An error that cannot be recovered (Module error)
		Blinking *1	Network construction error
		Double flash *3	Communication error (Watchdog Timer Timeout)
	-	OFF	No abnormality or the power is OFF
Link/ Activity	Green	Illuminating	Linked (Communication traffic not detected)
		Flickering *4	Linked (Communication traffic detected)
	-	OFF	No link or the power is OFF

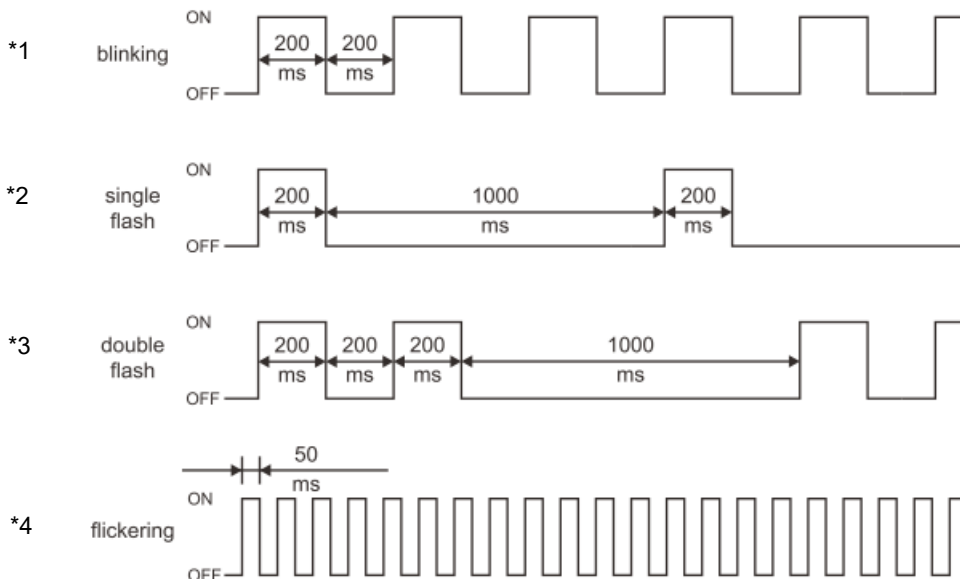

## 4.4 Wiring

### 4.4.1 Wiring (example)

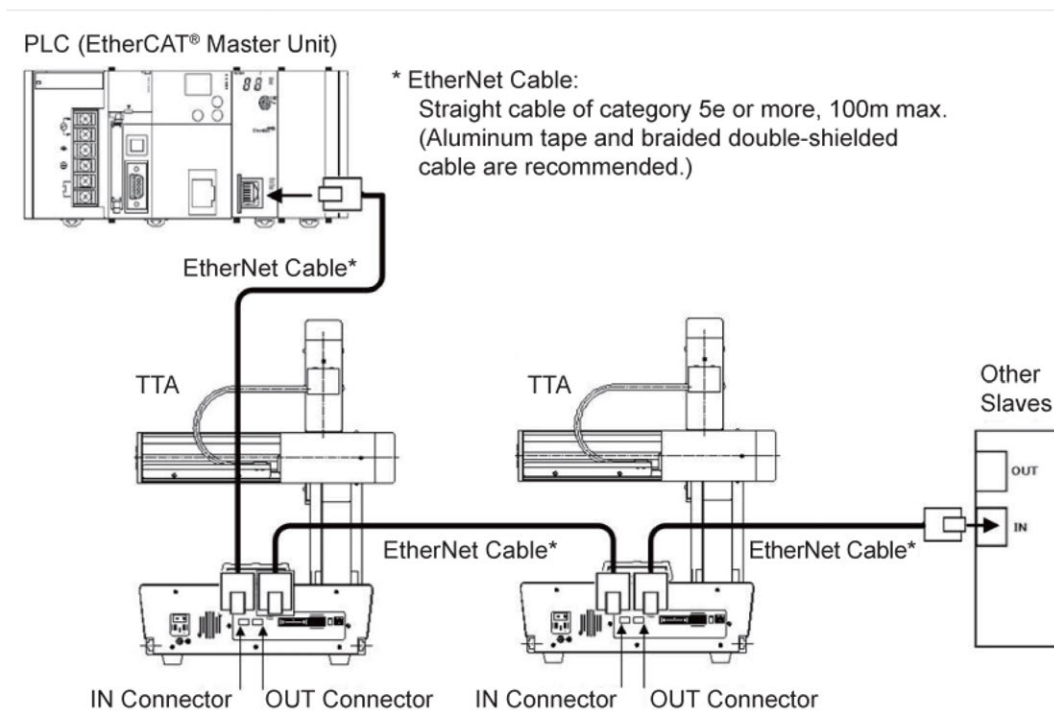

- Note 1 Only the daisy chain is supported in the network topology.
- Note 2 There are IN and OUT designated for the communication port for EtherCAT®.  
Be careful not to plug in the communication cable in the wrong way.
- Note 3 Terminal processing is not required.

### 4.4.2 Connector Pin Layout

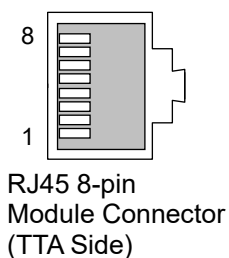

Pin No.	Signal Name	Signal Abbreviation
1	Data transmitted +	TD+
2	Data transmitted -	TD-
3	Data received +	RD+
4	Not used	
5	Not used	
6	Data received -	RD-
7	Not used	
8	Not used	
Connector Hood	Grounding pin for security	FG

## 4.5 Setting

Set to the TTA parameters in the controller by using a teaching tool.

Place the front panel's AUTO/MANU switch in the MANU position.

The versions of teaching tool compatible with EtherCAT® are as follows:

- XSEL PC software : from V10.00.00.00
- TB-01/TB-02 : from V1.00
- TB-03 : from V1.80

### 4.5.1 Parameter Setting

#### [1] Check of Network Module Type

Confirm that the 1<sup>st</sup> digit or 2<sup>nd</sup> digit of I/O Parameter No.225 Network I/F Module Control setting is showing "6" (EtherCAT®).

The digit to check will differ depending on the position to mount EtherCAT® board (Check the mounted on I/O2: 1<sup>st</sup> digit, mounted on I/O3: 2<sup>nd</sup> digit)

No.	Parameter name	Default	Input Range	Unit	Remarks
225	Extension I/O Control	*6H 6*H	For reference only	-	Bit 0 to 3: I/O2 Module Type Bit 4 to 7: I/O3 Module Type (0h: Not Mounted 1h: CC-Link, 2h: DeviceNet, 3h: PROFIBUS, 4h to 5h: System Reservation, 6h: EtherCAT®, 7h: EtherNet/IP, 8h: System Reservation, 9h: PIO)

The setting of this parameter is established at the delivery. For EtherCAT®, it is shown as "\*\*6H" or "6\*H".

#### [2] Node Address Setting

Set the node address to I/O parameter No.226 or 237.

- When the node address allocation is automatically conducted from master : set to 0
- When the node address allocation is fixed : set to 1 to 65535

No.	Parameter name	Default (reference)	Input Range	Unit	Remarks
226	I/O2 Fieldbus Node Address	0	0 to 99999999	-	0: Automatic Allocation Conducted from MasterUnit 1 to 65535: Fixed Allocation
237	I/O3 Fieldbus Node Address				

"D75: Fieldbus Parameter Error" will occur when a value out of the settable range gets set.

#### [3] Baud Rate Setting

It is unnecessary to establish the baud rate setting. It is fixed to 100BASE-TX (full-double).

[4] I/O Port Assignment Classification Setting

Check the I/O port assignment classification setting is "0" to I/O Parameter No.1.

No.	Parameter name	Default (reference)	Input Range	Unit	Remarks
1	I/O Port Allocation Type	0	For reference only	-	0: Fixed Allocation

[5] Number of I/O Port Setting

When mounting in I/O2, set the number of ports to be used for I/O Parameters No.14 to 15.  
When mounting in I/O3, set the number of ports to be used for I/O Parameters No.231 to 232.  
Set a number that is a multiple of 8.

No.	Parameter name	Default (reference)	Input Range	Unit	Remarks
14	I/O2 Fieldbus Number of Remote Input Ports	0	0 to 240	-	Multiples of 8
15	I/O2 Fieldbus Number of Remote Output Ports	0	0 to 240	-	Multiples of 8
231	I/O3 Fieldbus Number of Remote Input Ports	0	0 to 240	-	Multiples of 8
232	I/O3 Fieldbus Number of Remote Output Ports	0	0 to 240	-	Multiples of 8

[6] I/O Port Top Number Setting

When mounting in I/O2, set the top port number of the port range used in I/O Parameters No.16 to 17.

When mounting in I/O3, set the top port number of the port range used in I/O Parameters No.233 to 234.

The values entered into these parameters must be evenly divisible by 8.

No.	Parameter name	Default (reference)	Input Range	Unit	Remarks
16	I/O2 Fix-Allocated Input Port Start No.	-1	-1 to 299	-	0 + (Multiples of 8) (0 to 299) (Unavailable when it is negative figure)
17	I/O2 Fix-Allocated Output Port Start No.	-1	-1 300 to 599	-	300 + (Multiples of 8) (300 to 599) (Unavailable when it is negative figure)
233	I/O2 Fix-Allocated Input Port Start No.	-1	-1 to 299	-	0 + (Multiples of 8) (0 to 299) (Unavailable when it is negative figure)
234	I/O2 Fix-Allocated Output Port Start No.	-1	-1 300 to 599	-	300 + (Multiples of 8) (300 to 599) (Unavailable when it is negative figure)

[7] EtherCAT® Board Use Setting

When mounting in I/O2, set “1” (Monitoring: use EtherCAT® board) to I/O Parameter No.18.  
 When mounting in I/O3, set “1” (Monitoring: use EtherCAT® board) to I/O Parameter No.235.

No.	Parameter name	Default (reference)	Input Range	Unit	Remarks
18	I/O2 Error Monitor	1	0 to 5	-	0: No Monitoring (Not to use EtherCAT® board) 1: Monitoring (use EtherCAT® board)
235	I/O2 Error Monitor	1	0 to 5	-	0: No Monitoring (Not to use EtherCAT® board) 1: Monitoring (use EtherCAT® board)

[8] Time Adjustment to Wait for TTA Link Establishment

Standby time to wait for the link to the master at the TTA startup is available to adjust.

When the setting value is C8H for example, it waits for 20s at the maximum for the establishment of the link with the master since the network I/F initialization.

Change this setting when TTA starts faster than the network master, which results in a generation of “A6B/D5D: Fieldbus Error (FBRS Link Error)” etc. can be used in time adjustment.

No.	Parameter name	Default (reference)	Input Range	Unit	Remarks
121	Network Attribute 2	C80000 <sub>H</sub>	0H to FFFFFFFF <sub>H</sub>	-	Bit 16 to 27: Value of Link Timeout at Fieldbus Initializing (100ms)

[9] Select the Input Port Data at Link Error (Remote I/O Communication)

It is available to select if having the input port data of TTA at link error to be cleared or to be held (remained). When the setting value is 0H for example, the TTA input port data for the applicable network to use at a link error is 0.

No.	Parameter name	Default (reference)	Input Range	Unit	Remarks
120	Network Attribute 1	640001 <sub>H</sub>	0H to FFFFFFFF <sub>H</sub>	-	Bit 28 to 31: Network I/F Module 1 Input port data select for link error (0: Clear, 1: Hold)
121	Network Attribute 2	C80000 <sub>H</sub>	0H to FFFFFFFF <sub>H</sub>	-	Bit 16 to 23: Value of Link Timeout at Fieldbus Initializing (100msec)

[10] Other Setting (Caution)

When using EtherCAT® master supporting only the slave specified fixed PDO mapping such as CJ1W-NC□81/NC□82 manufactured by Omron, set the bit from 28 to 31 in the following parameter to 1h. (Example: C80000<sub>H</sub> → 10C80000<sub>H</sub>)

No.	Parameter name	Default (reference)	Input Range	Unit	Remarks
121	Network Attribute 2	C80000 <sub>H</sub>	0H to FFFFFFFF <sub>H</sub>	-	Bit 28 to 31: EtherCAT® PDO Mapping Type (0: Arianle, 1: Fixed at 32 bytes)

4.5.2 Example for Parameter Settings

(1) Example for when using only EtherCAT®

It is how to establish the setting when using EtherCAT® to 240 ports of each input and output from the top of the I/O ports, and no other I/O port (for Standard I/O, Extension I/O2 etc.) is to be used.

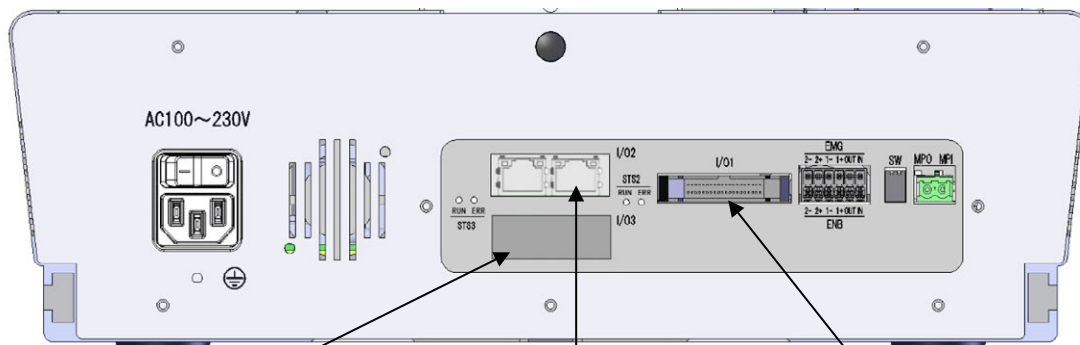

Extension I/O2 (I/O3)  
Not used

Related Parameter No.231 to 235

Extension I/O1 (I/O2)  
EtherCAT® Board Equipped  
Input Port No.48 to 287  
Output Port No.348 to 587

Related Parameter No.14 to 18

Standard I/O Board (I/O1)  
Not used

Related Parameter No.2, 3, 10

● I/O Parameter

No.	Parameter name	Default (reference)	Input Range	Unit	Remarks
1	I/O Port Allocation Type	0	For reference only	0	0: Fixed Allocation
2	I/O Fix-Allocated Input Port Start No.	0	-1 to 299	0	0 + (Multiples of 8) [Ineffective when -1 is selected]
3	I/O1 Fix-Allocated Output Port Start No.	300	-1 300 to 599	300	300 + (Multiples of 8) [Ineffective when -1 is selected]
10	I/O1 Error Monitoring	1	0 to 5	0	0: No Monitoring (Not to use I/O board) 1: Monitoring 2: Monitoring (Not to monitor 24V I/O power related error) 3: Monitoring (To monitor only 24V I/O power related error)
14	I/O2 Fieldbus Number of Remote Input Ports	0	0 to 240	240	Multiples of 8
15	I/O2 Fieldbus Number of Remote Output Ports	0	0 to 240	240	Multiples of 8
16	I/O2 Fix-Allocated Input Port Start No.	-1	-1 to 299	48	0 + (Multiples of 8) [Ineffective when -1 is selected]
17	I/O2 Fix-Allocated Output Port Start No.	-1	-1 300 to 599	348	300 + (Multiples of 8) [Ineffective when -1 is selected]
18	I/O2 Error Monitoring	1	0 to 5	1	0: No Monitoring (Not to use I/O2 module) 1: Monitoring
120	Network Attribute 1	640001 <sub>H</sub>	0 <sub>H</sub> to FFFFFFF <sub>H</sub>	Optional	Bit 28 to 31: I/O2 Fieldbus Link Error / Input Port Data Select at PIO Power Supply Error (0: Clear, 1: Hold)

No.	Parameter name	Default (reference)	Input Range	Unit	Remarks
121	Network Attribute 2	C80000 <sub>H</sub>	0 <sub>H</sub> to FFFFFFFF <sub>H</sub>	Optional	Bit 8 to 11: I/O3 Fieldbus Link Error / Input Port Data Select at PIO Power Supply Error (0: Clear, 1: Hold) Bit 16 to 27: Link Timeout Value at Fieldbus Initialization (100ms) Bit 28 to 31: EtherCAT <sup>®</sup> PDO Mapping Type (0: Variable, 1: Fixed at 32 bytes)
225	Extension I/O Control	*6 <sub>H</sub> 6* <sub>H</sub>	For reference only	06	Bit 0 to 3: I/O2 Module Type 6: EtherCAT <sup>®</sup> Bit 4 to 7: I/O3 Module Type 0: Not Mounted
226	I/O2 Fieldbus Node Address	0	0 to 65535	0	0: Make setting from master 1 to 65535: Fix-Allocation
231	I/O3 Fieldbus Number of Remote Input Ports	0	0 to 240	0	Multiples of 8
232	I/O3 Fieldbus Number of Remote Output Ports	0	0 to 240	0	Multiples of 8
233	I/O3 Fix-Allocated Extension Input Port Start No.	-1	-1 to 299	-1	0 + (Multiples of 8) [Ineffective when -1 is selected]
234	I/O3 Fix-Allocated Extension Input Port Start No.	-1	-1 300 to 599	-1	300 + (Multiples of 8) [Ineffective when -1 is selected]
235	I/O3 Error Monitoring	1	0 to 5	0	0: No Monitoring (Not to use I/O3 module) 1: Monitoring
237	I/O3 Fieldbus Node Address	0	0 to 65535	0	0: Make setting from master 1 to 65535: Fix-Allocation

 **Caution:** When not using Standard I/O Board (I/O1), set 0 in Parameter No. 2 “Output Port Start Number at I/O1 Fixed Assignment” and 300 in No. 3 “Output Port Start Number at I/O1 Fixed Assignment”.  
As setting -1 (Invalid) in Parameter No. 2 and No. 3 makes the internal DI and internal DO unused, the function switch on the front panel and the status LED lamps on the panel window will become non-functional.

- (2) Example for when using Standard I/O and EtherCAT® together  
 This is a setting to use standard I/O board (16 points each for input and output) and EtherCAT® on extension (I/O2) at 240 points of each for input and output.

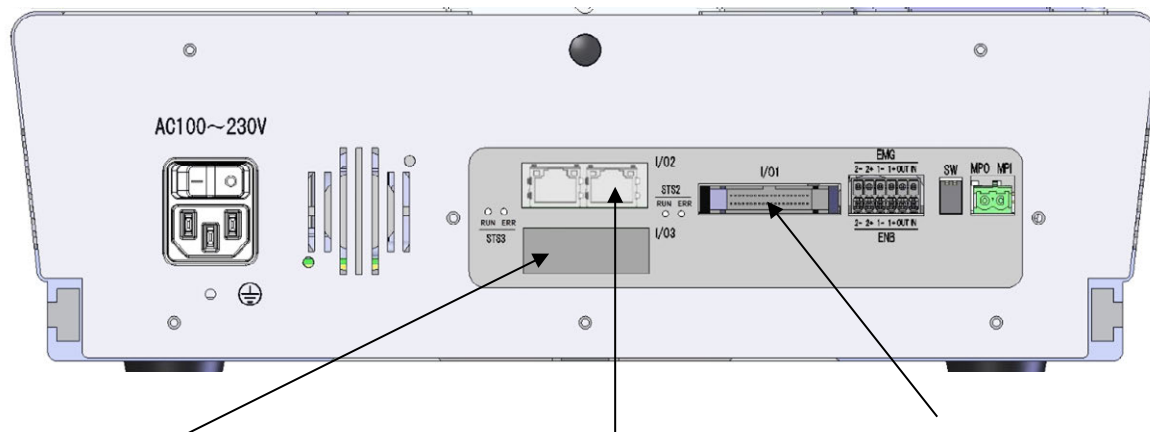

Extension I/O2 (I/O3)

Not used

Related Parameter No.231 to

Extension I/O1 (I/O2)

EtherCAT® Board Equipped

Input Port No.48 to 287

Output Port No.348 to 587

Related Parameter No.14 to 18

Standard I/O Board (I/O1)

Not used

Input Port No. 16 to 31

Output Port No. 316 to 331

Related Parameter No.2, 3, 10

### ● I/O Parameter

No.	Parameter name	Default (reference)	Input Range	Unit	Remarks
1	I/O Port Allocation Type	0	For reference only	0	0: Fixed Allocation
2	I/O1 Fix-Allocated Input Port Start No.	0	-1 to 299	0	0 + (Multiples of 8) [Ineffective when -1 is selected]
3	I/O1 Fix-Allocated Output Port Start No.	300	-1 300 to 599	300	300 + (Multiples of 8) [Ineffective when -1 is selected]
10	I/O1 Error Monitoring	1	0 to 5	1	0: No Monitoring (Not to use I/O board) 1: Monitoring 2: Monitoring (Not to monitor 24V I/O power related error) 3: Monitoring (To monitor only 24V I/O power related error)
14	I/O2 Fieldbus Number of Remote Input Ports	0	0 to 240	240	Multiples of 8
15	I/O2 Fieldbus Number of Remote Output Ports	0	0 to 240	240	Multiples of 8
16	I/O2 Fix-Allocated Input Port Start No.	-1	-1 to 299	48	0 + (Multiples of 8) [Ineffective when -1 is selected]
17	I/O2 Fix-Allocated Output Port Start No.	-1	-1 300 to 599	348	300 + (Multiples of 8) [Ineffective when -1 is selected]
18	I/O2 Error Monitoring	1	0 to 5	1	0: No Monitoring (Not to use I/O2 module) 1: Monitoring
120	Network Attribute 1	640001 <sub>H</sub>	0 <sub>H</sub> to FFFFFFF <sub>H</sub>	Optional	Bit 28 to 31: I/O2 Fieldbus Link Error / Input Port Data Select at PIO Power Supply Error (0: Clear, 1: Hold)
121	Network Attribute 2	C80000 <sub>H</sub>	0 <sub>H</sub> to FFFFFFF <sub>H</sub>	Optional	Bit 8 to 11: I/O3 Fieldbus Link Error / Input Port Data Select at PIO Power Supply Error (0: Clear, 1: Hold) Bit 16 to 27: Link Timeout Value at Fieldbus Initialization (100ms) Bit 28 to 31: EtherCAT® PDO Mapping Type (0: Variable, 1: Fixed at 32 bytes)

No.	Parameter name	Default (reference)	Input Range	Unit	Remarks
225	Extension I/O Control	*6 <sub>H</sub> 6* <sub>H</sub>	00 <sub>H</sub> to 37 <sub>H</sub>	06	Bit 0 to 3: I/O2 Module Type 6: EtherCAT® Bit 4 to 7: I/O3 Module Type 0: Not Mounted
226	I/O2 Fieldbus Node Address	0	0 to 65535	0	0: Make setting from master 1 to 65535: Fix-Allocation
231	I/O3 Fieldbus Number of Remote Input Ports	0	0 to 256	0	Multiples of 8
232	I/O3 Fieldbus Number of Remote Output Ports	0	0 to 256	0	Multiples of 8
233	I/O3 Fix-Allocated Extension Input Port Start No.	-1	-1 to 299	-1	0 + (Multiples of 8) [Ineffective when -1 is selected]
234	I/O3 Fix-Allocated Extension Input Port Start No.	-1	-1 300 to 599	-1	300 + (Multiples of 8) [Ineffective when -1 is selected]
235	I/O3 Error Monitoring	1	0 to 5	0	0: No Monitoring (Not to use I/O3 module) 1: Monitoring
237	I/O3 Fieldbus Node Address	0	0 to 65535	0	0: Make setting from master 1 to 65535: Fix-Allocation

(3) Example for when using extension I/O2 only EtherCAT®

It is the setting when EtherCAT® is used on 160 points for input and 200 points for output from the extension I/O2 (I/O3), and other input and output ports are not to be used (for standard I/O and extension I/O2).

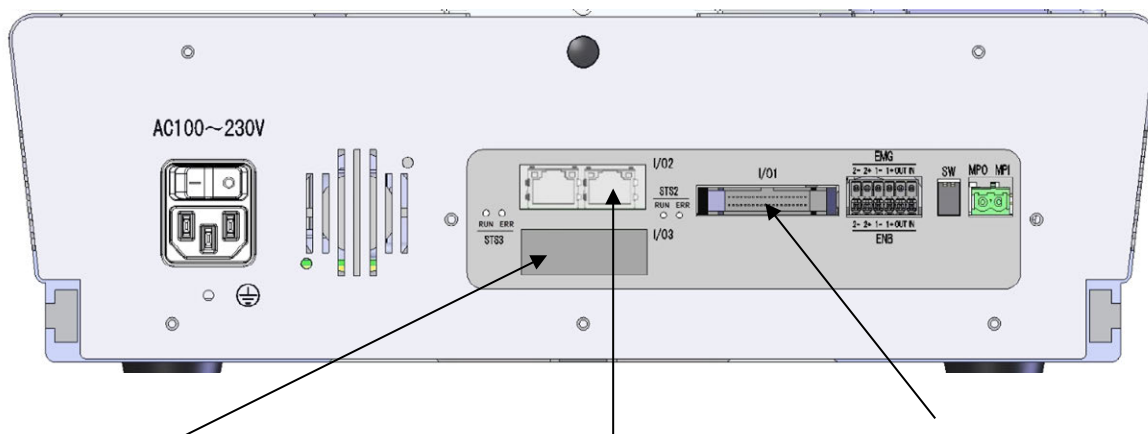

Extension I/O2 (I/O3)

EtherCAT® Board Equipped  
Input Port No.48 to 207  
Output Port No.348 to 547

Extension I/O1 (I/O2)

Not used  
Related Parameter No.14 to 18

Standard I/O Board (I/O1)

Not used  
Related Parameter No.2, 3, 10

Related Parameter No.231 to 235

● I/O Parameter

No.	Parameter name	Default (reference)	Input Range	Unit	Remarks
1	I/O Port Allocation Type	0	For reference only	0	0: Fixed Allocation
2	I/O Fix-Allocated Input Port Start No.	0	-1 to 299	0	0 + (Multiples of 8) [Ineffective when -1 is selected]
3	I/O Fix-Allocated Output Port Start No.	300	-1 300 to 599	300	300 + (Multiples of 8) [Ineffective when -1 is selected]
10	I/O Error Monitoring	1	0 to 5	0	0: No Monitoring (Not to use I/O board) 1: Monitoring 2: Monitoring (Not to monitor 24V I/O power related error) 3: Monitoring (To monitor only 24V I/O power related error)
14	I/O Fieldbus Number of Remote Input Ports	0	0 to 240	0	Multiples of 8
15	Network I/F Module 1 Number of Remote Output Ports	0	0 to 240	0	Multiples of 8
16	I/O Fix-Allocated Input Port Start No.	-1	-1 to 299	-1	0 + (Multiples of 8) [Ineffective when -1 is selected]
17	I/O Fix-Allocated Output Port Start No.	-1	-1 300 to 599	-1	300 + (Multiples of 8) [Ineffective when -1 is selected]
18	I/O Error Monitoring	1	0 to 5	1	0: No Monitoring (Not to use I/O2 module) 1: Monitoring
120	Network Attribute 1	640001 <sub>H</sub>	0 <sub>H</sub> to FFFFFFF <sub>H</sub>	Optional	Bit 28 to 31: I/O2 Fieldbus Link Error / Input Port Data Select at PIO Power Supply Error (0: Clear, 1: Hold)
121	Network Attribute 2	C80000 <sub>H</sub>	0 <sub>H</sub> to FFFFFFF <sub>H</sub>	Optional	Bit 8 to 11: I/O3 Fieldbus Link Error / Input Port Data Select at PIO Power Supply Error (0: Clear, 1: Hold) Bit 16 to 27: Link Timeout Value at Fieldbus Initialization (100ms) Bit 28 to 31: EtherCAT® PDO Mapping Type (0: Variable, 1: Fixed at 32 bytes)

No.	Parameter name	Default (reference)	Input Range	Unit	Remarks
225	Extension I/O Control	*6 <sub>H</sub> 6* <sub>H</sub>	For reference only	60	Bit 0 to 3: I/O2 Module Type 6: EtherCAT® Bit 4 to 7: I/O3 Module Type 6: EtherCAT®
226	I/O2 Fieldbus Node Address	0	0 to 65535	0	0: Make setting from master 1 to 65535: Fix-Allocation
231	I/O3 Fieldbus Number of Remote Input Ports	0	0 to 240	160	Multiples of 8
232	I/O3 Fieldbus Number of Remote Output Ports	0	0 to 240	200	Multiples of 8
233	I/O3 Fix-Allocated Extension Input Port Start No.	-1	-1 to 299	48	0 + (Multiples of 8) [Ineffective when -1 is selected]
234	I/O3 Fix-Allocated Extension Input Port Start No.	-1	-1 300 to 599	348	300 + (Multiples of 8) [Ineffective when -1 is selected]
235	I/O3 Error Monitoring	1	0 to 5	0	0: No Monitoring (Not to use I/O3 module) 1: Monitoring
237	I/O3 Fieldbus Node Address	0	0 to 65535	0	0: Make setting from master 1 to 65535: Fix-Allocation

⚠ Caution: When not using Standard I/O Board (I/O1), set 0 in Parameter No. 2 "Output Port Start Number at I/O1 Fixed Assignment" and 300 in No. 3 "Output Port Start Number at I/O1 Fixed Assignment".  
As setting -1 (Invalid) in Parameter No. 2 and No. 3 makes the internal DI and internal DO unused, the function switch on the front panel and the status LED lamps on the panel window will become non-functional.

## 4.6 I/O Ports of TTA

It is available to add special functions beside the general-purposed input and output in the I/O ports. [Refer to TTA Controller Operation Manual 4.6 How to Use Internal DIO, Chapter 5 Parameter for the details.]

### ● I/O Port Setting at Delivery

Those features described in brackets [ ] are not established at the delivery.

Type	Port No.	Function	Type	Port No.	Function
Internal DI (I/O1)	000	Start	Internal DO (I/O1)	300	ALM (LED on the front panel)
	001	Switch No.1 (Additional Switch)		301	RDY (LED on the front panel)
	002	For future expansion		302	EMG (LED on the front panel)
	003			303	Automatic operation mode (start switch LED)
	004			304	HPS (LED on the front panel)
	005	Switch No.2 (Additional Switch)		305	For future expansion
	006	Switch No.3 (Additional Switch)		306	
	007	Program number specification		307	
	008	Ones place of the digital switch		308	Internal DI No. 001 ON/OFF
	009	Tens place of the digital switch		309	Internal DI No. 002 ON/OFF
	010			310	Internal DI No. 003 ON/OFF
	011	Program number specification		311	Internal DI No. 004 ON/OFF
	012	Tens place of the digital switch		312	Internal DI No. 005 ON/OFF
	013			313	Internal DI No. 006 ON/OFF
	014	Switch No.4 (Additional Switch)		314	For future expansion
015		315	Internal DI No. 015 ON/OFF		
External DI (I/O1)	016 to 031	General-purpose input (I/O connector on the rear panel)	External DO (I/O1)	316 to 331	General-purpose output (I/O connector on the rear panel)
Internal DI (I/O1)	032	For future expansion	Internal DO (I/O1)	332	7-segment user display digit specification
	033			333	7-segment user display digit specification
	034			For future expansion	
	035				335
	036			336	
	037			337	7-segment display refresh
	038			338	7-segment user/system alternate display
	039			339	7-segment user display specification
	040			340	DT0 (7-segment user display bit)
	041			341	DT1 (7-segment user display bit)
	042			342	DT2 (7-segment user display bit)
	043			343	DT3 (7-segment user display bit)
	044			344	DT4 (7-segment user display bit)
	045			345	DT5 (7-segment user display bit)
	046			346	DT6 (7-segment user display bit)
047	347	For future expansion			

Type	Port No.	Function	Type	Port No.	Function
External DI (Ether CAT®)	048	General-purpose input	External DO (Ether CAT®)	348	Alarm output
	049	[Software reset]		349	Ready output
	050	[Servo ON]		350	Emergency stop output
	051	[Auto program start]		351	General-purpose output
	052	[Software interlock]		352	
	053	[Pause reset]		353	
	054	[Pause]		354	
	055	General-purpose input		355	
	056			356	
	057			357	
	058			358	
	059			359	
	060	General-purpose input		360	
	061			361	
	062			362	
	063			363	
064	General-purpose input	364	General-purpose output		
to		to			
287		587			

(Note) Number of I/O ports is input 000 to 299 (300 points max.), and output 300 to 599 (300 points max.). Be careful of the number of I/O ports when using EtherCAT® and PIO together.

(Note) In this table, shows the settings when EtherCAT® Connection Board is installed in "I/O2". For when the board is installed in "I/O3", refer to Instruction Manual of TTA.

## 4.7 I/O Port and Data Reading and Writing

The initial setting of SEL language commands for the operation of I/O (input and output) ports of TTA is set to execute reading and writing without the data being exchanged.

Shown below is an example for the assignments on the EtherCAT® master side and TTA side.

[TTA side output domain ⇒ EtherCAT® master side input domain]

Address	Bit 7 (MSB)	6	5	4	3	2	1	0 (LSB)
TTA Output Port Number	355	354	353	352	351	350	349	348
EtherCAT® Input word address	0 (lower-order byte)							
TTA Output Port Number	363	362	361	360	359	358	357	356
EtherCAT® Input word address	0 (host byte)							
TTA Output Port Number	371	370	369	368	367	366	365	364
EtherCAT® Input word address	1 (lower-order byte)							
TTA Output Port Number	379	378	377	376	375	374	373	372
EtherCAT® Input word address	1 (host byte)							

⋮

- Example Data (1234h) from TTA is changed to 1234h in EtherCAT®.

TTA	HEX	1	2	3	4
	BIN	0001	0010	0011	0100

↓ ↓

Ether CAT® Master	HEX	1	2	3	4
	BIN	0001	0010	0011	0100

[EtherCAT® master side output domain ⇒ TTA side input domain]

Address	Bit 7 (MSB)	6	5	4	3	2	1	0 (LSB)
TTA Input Port Number	55	54	53	52	51	50	49	48
EtherCAT® Output word address	0 (lower-order byte)							
TTA Input Port Number	63	62	61	60	59	58	57	56
EtherCAT® Output word address	0 (host byte)							
TTA Input Port Number	71	70	69	68	67	66	65	64
EtherCAT® Output word address	1 (lower-order byte)							
TTA Input Port Number	79	78	77	76	75	74	73	72
EtherCAT® Output word address	1 (host byte)							

⋮

- Example Data (1234h) from EtherCAT® master is changed to 1234h in TTA.

EtherCAT® Master	HEX	1	2	3	4
	BIN	0001	0010	0011	0100

↓ ↓

TTA	HEX	1	2	3	4
	BIN	0001	0010	0011	0100

●Reference How to Read and Write with Swapping Host 8 Bits with Lower 8 Bits for Every 16-Bit Data

When conducting reading and writing with swapping the host 8 bits with lower 8 bits for every 16-bit data, set Format Type to 1 (Swap host 8 bits with lower 8 bits for every 16-bit data) with FMIO Command before executing an input and output port operation command such as IN Command and OUT Command in TTA.

[Refer to TTA Operation Manual.]

Shown below is an example for the assignments on EtherCAT® master side and TTA controller side.

[EtherCAT® master side output domain ⇒ TTA side input domain]

Address	Bit 7 (MSB)	6	5	4	3	2	1	0 (LSB)
TTA Input Port Number	355	354	353	352	351	350	349	348
EtherCAT® Output bit address	63	62	61	60	59	58	57	56
EtherCAT® Output word address	0 (host byte)							
TTA Input Port Number	363	362	361	360	359	358	357	356
EtherCAT® Output bit address	55	54	53	52	51	50	49	48
EtherCAT® Output word address	0 (lower-order byte)							
TTA Input Port Number	371	370	369	368	367	366	365	364
EtherCAT® Output bit address	79	78	77	76	75	74	73	72
EtherCAT® Output word address	1 (host byte)							
TTA Input Port Number	371	370	369	368	367	366	365	364
EtherCAT® Output bit address	71	70	69	68	67	66	65	64
EtherCAT® Output word address	1 (lower-order byte)							

⋮

● Example Data (1234h) from EtherCAT® master is changed to 3412h in TTA.

EtherCAT® Master	HEX	1	2	3	4
	BIN	0001	0010	0011	0100
TTA	HEX	3	4	1	2
	BIN	0011	0100	0001	0010

## 5. MSEL

### 5.1 Operation Modes and Functions

MSEL applicable for EtherCAT® are applicable for the remote I/O control<sup>(\*1)</sup> (240 points max. for each input and output).

- \*1 I/O port is controlled in one port unit. I/O port is a point to receive and send data located inside the MSEL. 1 port can handle data of 1 contact (1 bit).  
Data are sent and received via either PIO (24V input and output) or field network.  
Connection to one port is available from only one of PIO or field network.  
Set a parameter to determine which of PIO or field network is to be used.

#### • Operation Image

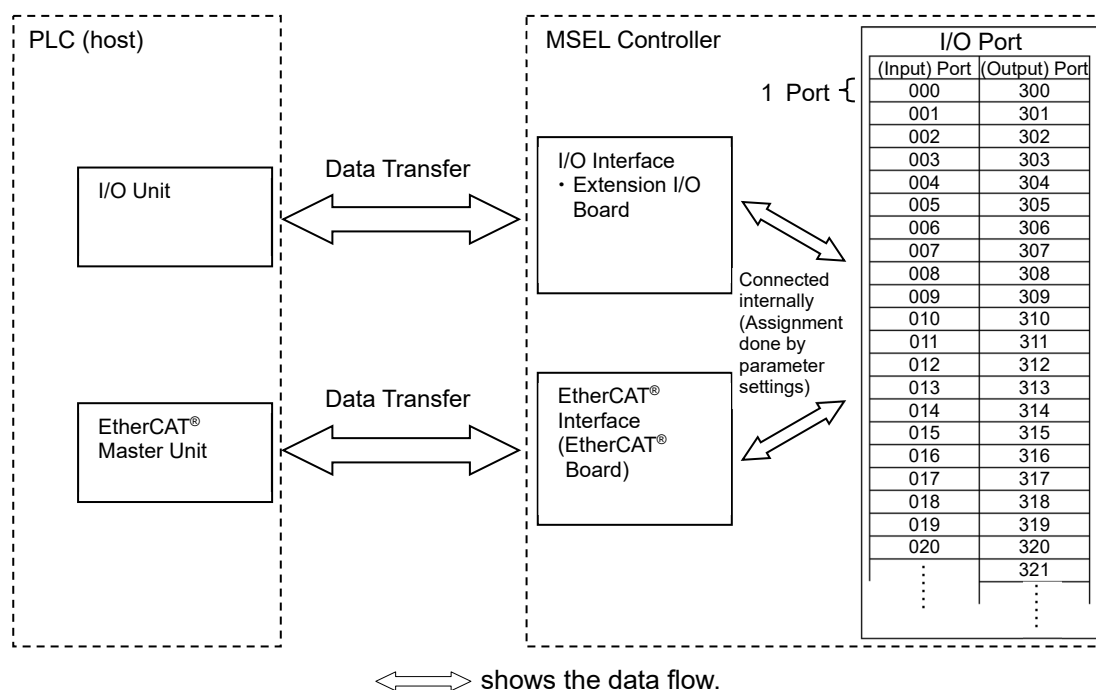

## 5.2 Model

The model code of each of MSEL applicable for EtherCAT® is as shown below.

- MSEL-PC(F)-□-□-□-□-EC
- MSEL-PG(F)-□-□-□-□-EC
- MSEL-PCX-□-□-□-□-EC
- MSEL-PGX-□-□-□-□-EC

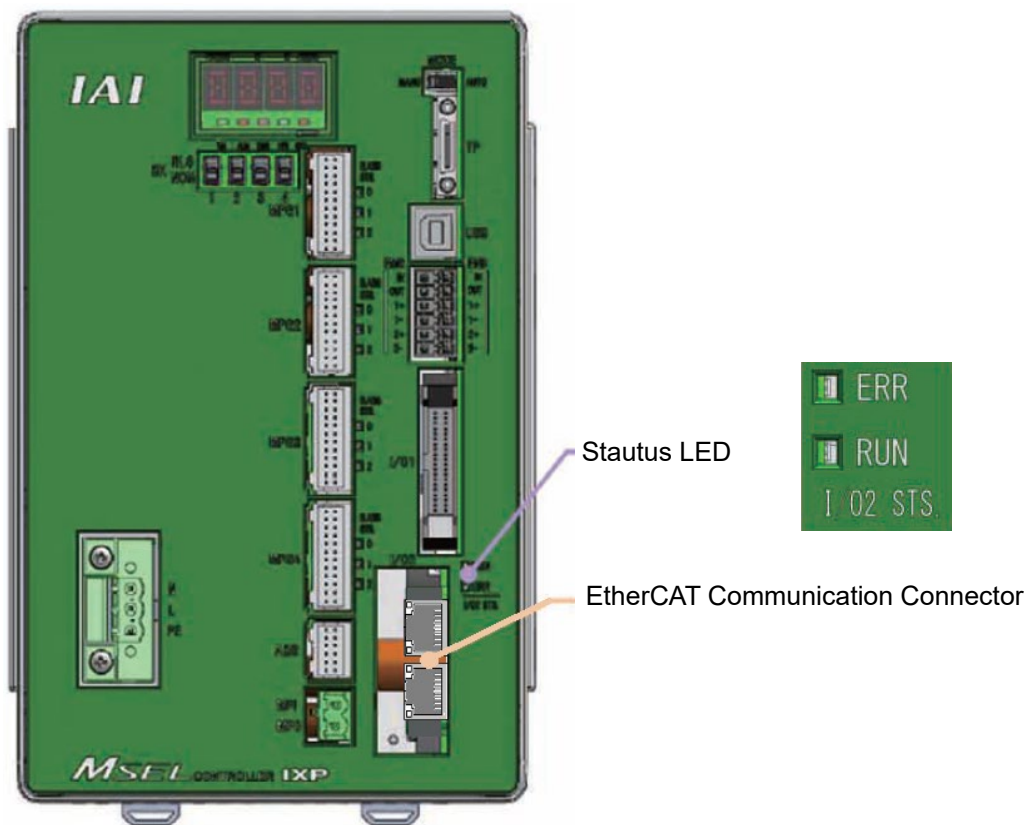

## 5.3 EtherCAT® Interface

### 5.3.1 Name of the Parts

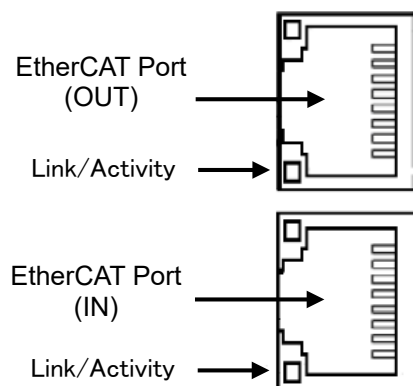

## 5.3.2 Monitor LED indications

LED	Color	Indication Status	Meaning
RUN	Green	Illuminating	Normal Communication Status. Both input and output are available for the process data. (EtherCAT® communication in "OPERATION" condition)
		Blinking *1	Under configuration condition in mailbox communication. Process data invalid. (EtherCAT® communication in "PRE-OPERATION" condition)
		Single flash *2	Configuration complete. Refer below for the process data communication. • Input : Inputting invalid • Output : Outputs 0 data (EtherCAT® communication in "SAFE-OPERATION" condition)
	Orange	Illuminating	An error that cannot be recovered (Module error)
	-	OFF	Initial condition (EtherCAT® communication in "INIT" condition) or the power is OFF
ERR	Orange	Illuminating	An error that cannot be recovered (Module error)
		Blinking *1	Network construction error
		Double flash *3	Communication error (Watchdog Timer Timeout)
	-	OFF	No abnormality or the power is OFF
Link/ Activity	Green	Illuminating	Linked (Communication traffic not detected)
		Flickering *4	Linked (Communication traffic detected)
	-	OFF	No link or the power is OFF

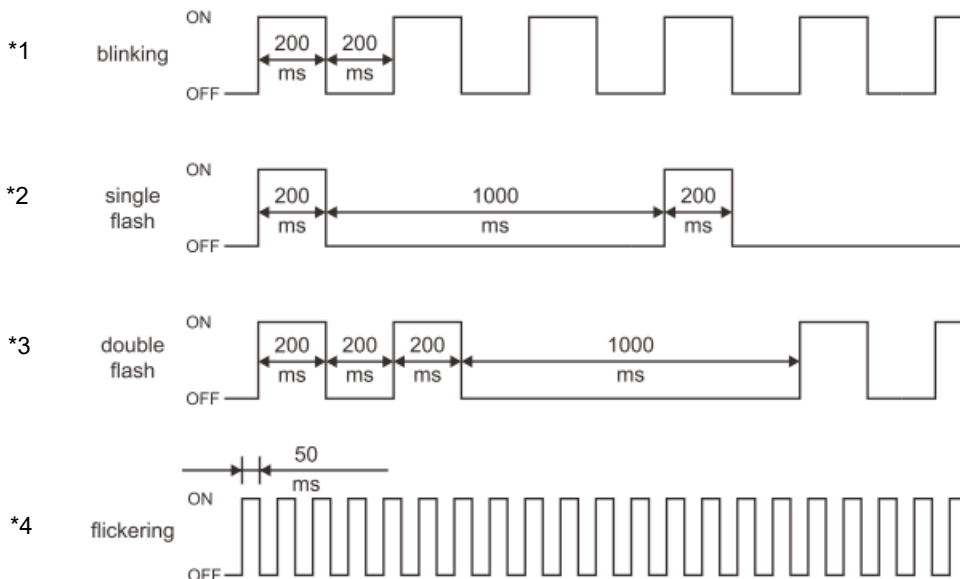

## 5.4 Wiring

### 5.4.1 Wiring (example)

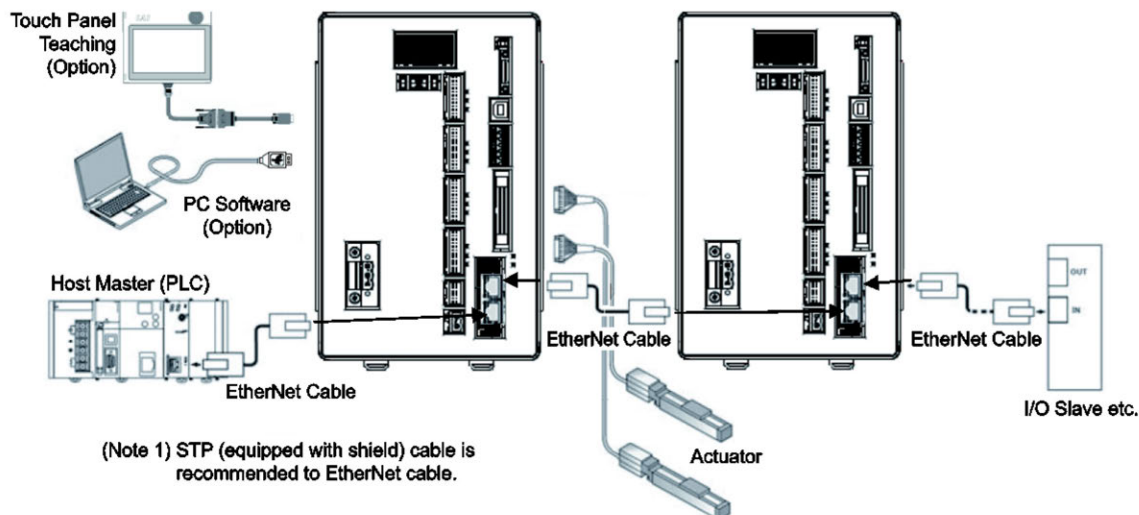

- Note 1 Only the daisy chain is supported in the network topology.
- Note 2 There are IN and OUT designated for the communication port for EtherCAT®. Be careful not to plug in the communication cable in the wrong way.
- Note 3 Terminal processing is not required.

### 5.4.2 Connector Pin Layout

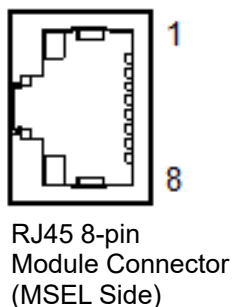

Pin No.	Signal Name	Signal Abbreviation
1	Data transmitted +	TD+
2	Data transmitted -	TD-
3	Data received +	RD+
4	Not used	
5	Not used	
6	Data received -	RD-
7	Not used	
8	Not used	
Connector Hood	Grounding pin for security	FG

## 5.5 Setting

Set to the MSEL parameters in the controller by using a teaching tool.  
Place the front panel's AUTO/MANU switch in the MANU position.  
The versions of teaching tool compatible with EtherCAT® are as follows:

- XSEL PC software : from V12.00.01.00
- TB-01 [MSEL-PCX/PGX] : from V1.02
- TB-01 [MSEL-PC(F)/PG(F)] : from V1.10
- TB-02 : from V1.00
- TB-03 : from V1.80

### 5.5.1 Parameter Setting

#### [1] Check of Network Module Type

Confirm that the 1<sup>st</sup> digit of I/O Parameter No.225 Extension I/O Control setting is showing “6” (EtherCAT®).

No.	Parameter name	Default	Input Range	Unit	Remarks
225	Extension I/O Control	*6H	For reference only	-	Bit 0 to 3: I/O2 Module Type Bit 4 to 7: I/O3 Module Type (0h: Not Mounted 1h: CC-Link, 2h: DeviceNet, 3h: PROFIBUS, 4h to 5h: System Reservation, 6h: EtherCAT®, 7h: EtherNet/IP, 8h: System Reservation, 9h: PIO)

The setting of this parameter is established at the delivery. For EtherCAT®, it is shown as “\*6H”.

#### [2] Node Address Setting

Set the node address to I/O parameter No.226.

- When the node address allocation is automatically conducted from master : set to 0
- When the node address allocation is fixed : set to 1 to 65535

No.	Parameter name	Default (reference)	Input Range	Unit	Remarks
226	I/O2 Fieldbus Node Address	0	0 to 99999999	-	0: Automatic Allocation Conducted from MasterUnit 1 to 65535: Fixed Allocation

“D75: Fieldbus Parameter Error” will occur when a value out of the settable range gets set.

#### [3] Baud Rate Setting

It is unnecessary to establish the baud rate setting. It is fixed to 100BASE-TX (full-double).

## [4] I/O Port Assignment Classification Setting

Check the I/O port assignment classification setting is "0" to I/O Parameter No.1.

No.	Parameter name	Default (reference)	Input Range	Unit	Remarks
1	I/O Port Allocation Type	0	For reference only	-	0: Fixed Allocation

## [5] Number of I/O Port Setting

Set the number of ports to be used for I/O Parameters No.14 to 15.

Set a number that is a multiple of 8.

No.	Parameter name	Default (reference)	Input Range	Unit	Remarks
14	I/O2 Fieldbus Number of Remote Input Ports	0	0 to 240	-	Multiples of 8
15	I/O2 Fieldbus Number of Remote Output Ports	0	0 to 240	-	Multiples of 8

## [6] I/O Port Top Number Setting

Set the top port number of the port range used in I/O Parameters No.16 to 17.

The values entered into these parameters must be evenly divisible by 8.

No.	Parameter name	Default (reference)	Input Range	Unit	Remarks
16	I/O2 Fix-Allocated Input Port Start No.	-1	-1 to 299	-	0 + (Multiples of 8) (0 to 299) (Unavailable when it is negative figure)
17	I/O2 Fix-Allocated Output Port Start No.	-1	-1 300 to 599	-	300 + (Multiples of 8) (300 to 599) (Unavailable when it is negative figure)

## [7] EtherCAT® Board Use Setting

Set "1" (Monitoring: use EtherCAT® board) to I/O Parameter No.18.

No.	Parameter name	Default (reference)	Input Range	Unit	Remarks
18	I/O2 Error Monitor	1	0 to 5	-	0: No Monitoring (Not to use EtherCAT® board) 1: Monitoring (use EtherCAT® board)

## [8] Time Adjustment to Wait for MSEL Link Establishment

Standby time to wait for the link to the master at the MSEL startup is available to adjust. When the setting value is C8H for example, it waits for 20s at the maximum for the establishment of the link with the master since the network I/F initialization.

Change this setting when MSEL starts faster than the network master, which results in a generation of "A6B/D5D: Fieldbus Error (FBRS Link Error)" etc. can be used in time adjustment.

No.	Parameter name	Default (reference)	Input Range	Unit	Remarks
121	Network Attribute 2	C80000 <sub>H</sub>	0H to FFFFFFF <sub>H</sub>	-	Bit 16 to 27: Value of Link Timeout at Fieldbus Initializing (100ms)

[9] Select the Input Port Data at Link Error (Remote I/O Communication)

It is available to select if having the input port data of MSEL at link error to be cleared or to be held (remained). When the setting value is 0H for example, the MSEL input port data for the applicable network to use at a link error is 0.

No.	Parameter name	Default (reference)	Input Range	Unit	Remarks
120	Network Attribute 1	640001 <sub>H</sub>	0 <sub>H</sub> to FFFFFFF <sub>H</sub>	-	Bit 28 to 31: Network I/F Module 1 Input port data select for link error (0: Clear, 1: Hold)

[10] Other Setting (Caution)

When using EtherCAT<sup>®</sup> master supporting only the slave specified fixed PDO mapping such as CJ1W-NC□81/NC□82 manufactured by Omron, set the bit from 28 to 31 in the following parameter to 1h. (Example: C80000<sub>H</sub> → 10C80000<sub>H</sub>)

No.	Parameter name	Default (reference)	Input Range	Unit	Remarks
121	Network Attribute 2	C80000 <sub>H</sub>	0 <sub>H</sub> to FFFFFFF <sub>H</sub>	-	Bit 28 to 31: EtherCAT <sup>®</sup> PDO Mapping Type (0: Ariable, 1: Fixed at 32 bytes)

## 5.5.2 Example for Parameter Settings

Example for the case standard I/O and EtherCAT® are used at the same time

This is a setting to use standard I/O board (16 points each for input and output) and EtherCAT® on extension I/O1 (I/O2) at 240 points of each for input and output.

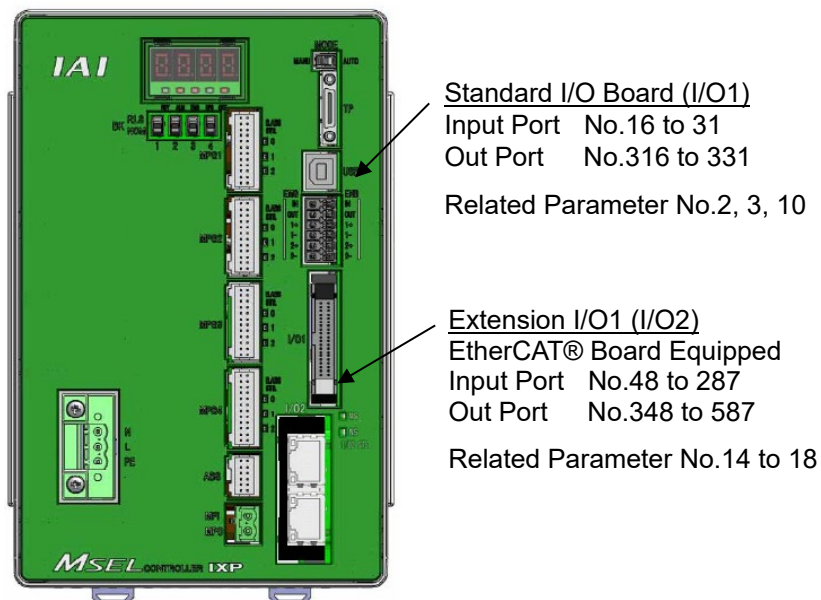

### • I/O Parameter

No.	Parameter name	Default (reference)	Input Range	Unit	Remarks
1	I/O Port Allocation Type	0	For reference only	0	0: Fixed Allocation
2	I/O1 Fix-Allocated Input Port Start No.	0	-1 to 299	0	0 + (Multiples of 8) [Ineffective when -1 is selected]
3	I/O1 Fix-Allocated Output Port Start No.	300	-1 300 to 599	300	300 + (Multiples of 8) [Ineffective when -1 is selected]
10	I/O1 Error Monitoring	1	0 to 5	0	0: No Monitoring (Not to use I/O board) 1: Monitoring 2: Monitoring (Not to monitor 24V I/O power related error) 3: Monitoring (To monitor only 24V I/O power related error)
14	I/O2 Fieldbus Number of Remote Input Ports	0	0 to 240	240	Multiples of 8
15	I/O2 Fieldbus Number of Remote Output Ports	0	0 to 240	240	Multiples of 8
16	I/O2 Fix-Allocated Input Port Start No.	-1	-1 to 299	48	0 + (Multiples of 8) [Ineffective when -1 is selected]
17	I/O2 Fix-Allocated Output Port Start No.	-1	-1 300 to 599	348	300 + (Multiples of 8) [Ineffective when -1 is selected]
18	I/O2 Error Monitoring	1	0 to 5	1	0: No Monitoring (Not to use I/O2 module) 1: Monitoring

No.	Parameter name	Default (reference)	Input Range	Unit	Remarks
120	Network Attribute 1	640001 <sub>H</sub>	0 to FFFFFFFF <sub>H</sub>	Optional	Bit 28 to 31: I/O2 Fieldbus Link Error / Input Port Data Select at PIO Power Supply Error (0: Clear, 1: Hold)
121	Network Attribute 2	C80000 <sub>H</sub>	0 to FFFFFFFF <sub>H</sub>	Optional	Bit 16 to 27: Link Timeout Value at Fieldbus Initialization (100ms) Bit 28 to 31: EtherCAT® PDO Mapping Type (0: Variable, 1: Fixed at 32 bytes)
225	Extension I/O Control	*6 <sub>H</sub>	00 <sub>H</sub> to 37 <sub>H</sub>	06	Bit 0 to 3: I/O2 Module Type 6: EtherCAT®
226	I/O2 Fieldbus Node Address	0	0 to 65535	0	0: Make setting from master 1 to 65535: Fix-Allocation

## 5.6 I/O Ports of MSEL

It is available to add special functions beside the general-purposed input and output in the I/O ports.

[Refer to MSEL Controller Operation Manual 2.2.5 PIO Circuit, Chapter 5 Parameter for the details.]

### ● I/O Port Setting at Delivery

Typr	Port No.	Function	Typr	Port No.	Function
Internal DI (I/O1)	000	For future expansion	Internal DO (I/O1)	300	ALM (LED on the front panel)
	001			301	RDY (LED on the front panel)
	002			302	EMG (LED on the front panel)
	003			303	For future expansion
	004			304	HPS (LED on the front panel)
	005			305	For future expansion
	006			306	
	007			307	
	008			308	
	009			309	
	010			310	
	011			311	
	012			312	
	013			313	
	014			314	
015	315				
External DI (I/O1)	016 to 031	General-purpose input	External DO (I/O1)	316 to 331	General-purpose output
Internal DI (I/O1)	032	For future expansion	Internal DO (I/O1)	332	7-segment user display digit specification
	033			333	7-segment user display digit specification
	034			334	For future expansion
	035			335	
	036			336	
	037			337	7-segment display refresh
	038			338	7-segment user/system alternate display
	039			339	7-segment user display specification
	040			340	DT0 (7-segment user display bit)
	041			341	DT1 (7-segment user display bit)
	042			342	DT2 (7-segment user display bit)
	043			343	DT3 (7-segment user display bit)
	044			344	DT4 (7-segment user display bit)
	045			345	DT5 (7-segment user display bit)
046	346	DT6 (7-segment user display bit)			
047	347	For future expansion			

Typr	Port No.	Function	Typr	Port No.	Function
External DI (Ether CAT®)	048	Program start	External DO (Ether CAT®)	348	Alarm output
	049	General-purpose input		349	Ready output
	050			350	Emergency-stop output
	051			351	General-purpose output
	052			352	
	053			353	
	054			354	
	055			Program number specification (BCD:1 / BIN:1)*	
	056	Program number specification (BCD:2 / BIN:2)*		356	
	057	Program number specification (BCD:4 / BIN:4)*		357	
	058	Program number specification (BCD:8 / BIN:8)*		358	
	059	Program number specification (BCD:10 / BIN:16)*		359	
	060	Program number specification (BCD:20 / BIN:32)*		360	
	061	Program number specification (BCD:40 / BIN:64)*		361	
	062	General-purpose input		362	
	063			363	
064 to 287	General-purpose input	364 to 587	General-purpose output		

\* Switching over between BCD and BIN in Program Number Indication should be conducted in IO Parameter No. 30 Input Function Select 000.

(1: Program Start BCD, 2: Program Start Binary (BIN))

(Note) Number of standard I/O ports is input 000 to 299 (300 points max.), and output 300 to 599 (300 points max.). Be careful of the number of I/O ports when using EtherCAT® and PIO together.

## 5.7 I/O Port and Data Reading and Writing

The initial setting of SEL language commands for the operation of I/O (input and output) ports of MSEL is set to execute reading and writing without the data being exchanged.

Shown below is an example for the assignments on the EtherCAT® master side and MSEL side.

[MSEL side output domain ⇒ EtherCAT® master side input domain]

Address	Bit 7 (MSB)	6	5	4	3	2	1	0 (LSB)
MSEL Output Port Number	355	354	353	352	351	350	349	348
EtherCAT® Input word address	0 (lower-order byte)							
MSEL Output Port Number	363	362	361	360	359	358	357	356
EtherCAT® Input word address	0 (host byte)							
MSEL Output Port Number	371	370	369	368	367	366	365	364
EtherCAT® Input word address	1 (lower-order byte)							
MSEL Output Port Number	379	378	377	376	375	374	373	372
EtherCAT® Input word address	1 (host byte)							

⋮

- Example Data (1234h) from MSEL is changed to 1234h in EtherCAT®.

MSEL	HEX	1	2	3	4
	BIN	0001	0010	0011	0100

↓ ↓

EtherCAT® Master	HEX	1	2	3	4
	BIN	0001	0010	0011	0100

[EtherCAT® master side output domain ⇒ MSEL side input domain]

Address	Bit 7 (MSB)	6	5	4	3	2	1	0 (LSB)
MSEL Input Port Number	55	54	53	52	51	50	49	48
EtherCAT® Output word address	0 (lower-order byte)							
MSEL Input Port Number	63	62	61	60	59	58	57	56
EtherCAT® Output word address	0 (host byte)							
MSEL Input Port Number	71	70	69	68	67	66	65	64
EtherCAT® Output word address	1 (lower-order byte)							
MSEL Input Port Number	79	78	77	76	75	74	73	72
EtherCAT® Output word address	1 (host byte)							

⋮

- Example Data (1234h) from EtherCAT® master is changed to 1234h in MSEL.

EtherCAT® Master	HEX	1	2	3	4
	BIN	0001	0010	0011	0100

↓ ↓

MSEL	HEX	1	2	3	4
	BIN	0001	0010	0011	0100

## ●Reference How to Read and Write with Swapping Host 8 Bits with Lower 8 Bits for Every 16-Bit Data

When conducting reading and writing with swapping the host 8 bits with lower 8 bits for every 16-bit data, set Format Type to 1 (Swap host 8 bits with lower 8 bits for every 16-bit data) with FMIO Command before executing an input and output port operation command such as IN Command and OUT Command in MSEL.

[Refer to MSEL Operation Manual.]

Shown below is an example for the assignments on EtherCAT® master side and MSEL controller side.

[EtherCAT® master side output domain ⇒ MSEL side input domain]

Address	Bit 7 (MSB)	6	5	4	3	2	1	0 (LSB)
MSEL Input Port Number	355	354	353	352	351	350	349	348
EtherCAT® Output bit address	63	62	61	60	59	58	57	56
EtherCAT® Output word address	0 (host byte)							
MSEL Input Port Number	363	362	361	360	359	358	357	356
EtherCAT® Output bit address	55	54	53	52	51	50	49	48
EtherCAT® Output word address	0 (lower-order byte)							
MSEL Input Port Number	371	370	369	368	367	366	365	364
EtherCAT® Output bit address	79	78	77	76	75	74	73	72
EtherCAT® Output word address	1 (host byte)							
MSEL Input Port Number	371	370	369	368	367	366	365	364
EtherCAT® Output bit address	71	70	69	68	67	66	65	64
EtherCAT® Output word address	1 (lower-order byte)							

⋮

## ● Example Data (1234h) from EtherCAT® master is changed to 3412h in MSEL.

EtherCAT® Master	HEX	1	2	3	4
	BIN	0001	0010	0011	0100
MSEL	HEX	3	4	1	2
	BIN	0011	0100	0001	0010



## 6. Appendix

### 6.1 Troubleshooting

- (1) In case it is not possible to connect the network, check the current condition on the display of monitoring LEDs of EtherCAT® Board. [Refer to Section 3.3.2 and 4.3.2 and 5.3.2.]  
Check the settings of the XSEL controller or MSEL or TTA and the settings of the master unit referring to the operation manuals of the master unit.
- (2) When an alarm is issued, an alarm code gets output to the panel window of the IAI controller.
  - 1) Based on the read alarm code, search the alarm description list in the operation manual for the each controller.
  - 2) Deal with it based on the description for the alarm code in question.  
The alarm codes listed below are those you will often see in the startup process.

#### ◎ Alarm Codes in Common with XSEL

Monitor LED	Contents	Cause and Remedy
ErG	Emergency Stop	It is not an alarm. <ul style="list-style-type: none"> <li>• This occurs when the emergency stop switch of a teaching tool such as the PC software is not released.</li> <li>• It is generated when the personal computer cable is not connected to the emergency stop switch box.</li> <li>• Check the emergency stop circuit.</li> </ul>
Enb	Safety Gate Remains Opening Deadman Switch OFF	It is not an alarm. <ul style="list-style-type: none"> <li>• It is generated when the system I/O ENB signal is opened. Check the ENB signal. (It is generated when the safety gate is open. Close the safety gate.)</li> <li>• This occurs when AUTO/MANU switch is on MANU and no teaching tool such as a PC is connected. Connect the teaching pendant or set the AUTO/MANU switch to "AUTO".</li> <li>• When the actuator is to be started up, hold the deadman switch on the teaching pendant to turn it ON.</li> </ul>
ACF	AC Power Interruption Momentary Power Failure Power Voltage Drop	The power voltage is not supplied properly. Check the power supply.
E914	Absolute Data Backup Battery Voltage Error	It will be generated in the case that the battery has not been attached, or the battery voltage is dropped. In the case of the actuator for the single-axis robots or orthogonal robots with the absolute data specifications, it is generated when the power is connected for the first time. Perform the absolute reset.
ED12	Encoder Disconnection Error	It is generated when the cable is broken or the encode cable is not connected to the controller. Check the wiring.
ED19	Encoder Reception Time Out	It is generated when the encoder is broken down, the cable is broken or the encoder cable is not connected to the controller.
EE69 EE6C	24V I/O Error DO Output Current Error	It is generated when the +24V power for I/O is not supplied. Check the power supply.  (How to start up the controller without connecting the I/O 24V power) Set the I/O parameter No.10 to 13 corresponding to the standard or extended I/O board to "0". (Note) I/O cannot be used.
ED5D	Fieldbus Error	This occurs when the network connection is not established. Check the parameters on IAI controller and the parameters on PLC. (Way to boot the controller without connecting to EtherCAT®) Set both the I/O parameter No.18 to "0".

◎ Other Alarm Codes Related to EtherCAT®

● Message Level Error

No.	Error name	Contents / Counteractions
A6B	Fieldbus Error (FBRS Link Error)	FBRS Link Error was detected.

● Cold Start Level Errors

No.	Error name	Contents / Counteractions
678	Extension I/O Port Assignment Parameter Error	There is an error in a parameter related to the extended I/O port assignment.
679	Extended I/O Port Assignment Number Overflow Error	The number of extended I/O port assignment exceeded the specification range.
67A	Extended I/O Port Duplicated Assignment Error	Extended I/O port assignment has duplicated.
D56	Fieldbus Error (MinACK Timeout)	The Min ACK Timeout was detected. Check the conditions of monitoring LEDs.
D59	Fieldbus Error (DPRAM Writing and Reading)	The DPRAM writing and reading error was detected. Check the conditions of monitoring LEDs.
D5A	Fieldbus Error (TOGGLE Timeout)	The TOGGLE Timeout was detected. Check the conditions of monitoring LEDs.
D5B	Fieldbus Error (Access Right Retry Over)	The Access Right Retry Over Error was detected. Check the conditions of monitoring LEDs. [Refer to section 3.3.2 and 4.3.2]
D5D	Fieldbus Error (FBRS Link Error)	The FBRS Link Error was detected. Check the conditions of monitoring LEDs.
D5E	Fieldbus Error (Mail BOX Response)	The Mail BOX Response Error was detected. Check the conditions of monitoring LEDs. [Refer to section 3.3.2 and 4.3.2]
D5F	Network I/F Module Class Mismatch Error	The type of I/F module specified in I/O Parameter No.225 and the type of network module actually mounted do not match. Check the setting in I/O Parameter No.225 and the combination of network I/F module actually mounted.
D75	Fieldbus Parameter Error	There is a failure in the Fieldbus Parameter. Check in I/O Parameters No.226.
D76	Fieldbus Module Unmounted Error	Fieldbus Module is unmounted.
D77	Fieldbus Error (Exception)	The Exception Error was detected. Refer to the operation manual of the field network board and check the conditions of monitoring LEDs on the Fieldbus.
E1F	I/O Assignment Parameter Error	It can be concerned that a value other than the input and output port number (-1 is acceptable) or a value other than Input and Output Board Top No. + [a multiple of 8] is input in I/O Parameter No.2 to 9, or a value other than [a multiple of 8] is input in I/O Parameter No.14 to 17.
E20	I/O Duplication Assignment Error	I/O assignment is duplicated. Check I/O Parameter No.2 to 9, 14 to 17, card model code (input and output number) in the slot and so on.
E21	I/O Assignment Number Overflow Error	I/O assignment has exceeded the specified range. Check I/O Parameter No.2 to 9, 14 to 17, card model code (input and output number) in the slot and so on.
E8F	Fieldbus Logic Error	It is a logic error at the Fieldbus initializing.

## 6.2 List of EtherCAT® Related Parameters

### [1] I/O Parameter of XSEL

No.	Parameter Name	Default (reference)	Input Range	Unit	Remarks
1	I/O Port Allocation Type	0	0 to 20	-	0: Fixed Allocation 1: Automatic Allocation  * Priority of I/O Port Assignment (No.0 to 299/No.300 to 599) (Network I/F Module 1 → I/O slot 1 (I/O1) Mounting board * Assigned for the range of continuous mounting from I/O slot 1 (I/O1) Mounting board = for safety) * Priority of extension I/O ports assignment of XSEL (No.1000 to 3999/No.4000 to 6999) (Network I/F Module 2 → Extension I/O unit → Communication between IA Net Controllers)
2	Standard I/O Fix-Allocated Input Port Start No.	0	-1 to 299	-	0 + (Multiples of 8) [Ineffective when -1 is selected]
3	Standard I/O Fix-Allocated Output Port Start No.	300	-1 300 to 599	-	300 + (Multiples of 8) [Ineffective when -1 is selected]
14	Network I/F Module 1 Number of Remote Input Ports	0	0 to 256	-	Multiples of 8
15	Network I/F Module 1 Number of Remote Output Ports	0	0 to 256	-	Multiples of 8
16	Network I/F Module 1 Fix-Allocated Input Port Start No.	-1	-1 to 299 1000 to 3999	-	0 + (Multiples of 8) (0 to 299) 1000 + (Multiples of 8) (1000 to 3999) (Unavailable when it is negative figure)
17	Network I/F Module 1 Fix-Allocated Output Port Start No.	-1	-1 300 to 599 4000 to 6999	-	300 + (Multiples of 8) (300 to 599) 4000 + (Multiples of 8) (4000 to 6999) (Unavailable when it is negative figure)
18	Network I/F Module 1 Error Monitoring	1	0 to 5	-	0: No Monitoring 1: Monitoring * There are some exceptions
120	Network Attribute 1	640001 <sub>H</sub>	0 <sub>H</sub> to FFFFFFF <sub>H</sub>	-	Bit 0 to 3 : System Reservation Bit 4 to 11 : Network I/F Module 1 Link Error Confirmation Timer Value (10ms) Bit 12 to 15 : For Future Extension Bit 16 to 27 : System Reservation Bit 28 to 31 : Network I/F Module 1 Input port data select for link error (0: Clear, 1: Hold)
121	Network Attribute 2	C80000 <sub>H</sub>	0 <sub>H</sub> to FFFFFFF <sub>H</sub>	Optional	Bits 8 to 11: Network I/F Module 2 Input port data select for link error (0: Clear, 1: Hold) Bits 16 to 27: Value of Link Timeout at initializing of the Fieldbus (100ms)
225	Network I/F Module Control	*6 (*06)	00 <sub>H</sub> to 37 <sub>H</sub> (000 <sub>H</sub> to 307 <sub>H</sub> ) Reference only	06 (006)	Bits 0 to 3: (Bits 0 to 7:) Network I/F Module 1 type 0: Not Mounted 6: EtherCAT® 7: EtherNet/IP Bits 4 to 7: (Bits 8 to 15:) Network I/F Module 2 type 0: Not Mounted 1: CC-Link 2: DeviceNet 3: PROFIBUS-DP 4 to C: System Reservation D: CC-Link IE Field (XSEL-RA/SA only)
	Those stated in brackets ( ) are for XSEL-RA/SA Series				

No.	Parameter Name	Default (reference)	Input Range	Unit	Remarks
226	Network I/F Module 1 Node Address	0	0 to 65535	-	<ul style="list-style-type: none"> <li>At CC-Link : 1 to 64</li> <li>At DeviceNet : 0 to 63</li> <li>At PROFIBUS : 0 to 125</li> <li>At EtherCAT® : 0 to 65535</li> </ul>
227	Network I/F Module 1 Baud Rate	0	0 to 9	-	<ul style="list-style-type: none"> <li>At CC-Link: (0: 156kbps, 1: 625kbps, 2: 2.5Mbps, 3: 5Mbps, 4: 10Mbps)</li> <li>At DeviceNet: (0: 125kbps, 1: 250kbps, 2: 500kbps)</li> <li>At EtherNet/IP: (0: Autonegotiation, 1: 10Mbps (Half-duplex), 2: 10Mbps (Full-duplex), 3: 100Mbps (Half-duplex), 4: 100Mbps (Full-duplex))</li> </ul> <p>* Setting establishment not necessary for PROFIBUS and EtherCAT®</p>
231	Network I/F Module 2 Number of Remote Input Ports	0	0 to 240	-	Multiples of 8
232	Network I/F Module 2 Number of Remote Output Ports	0	0 to 240	-	Multiples of 8
233	Network I/F Module 2 Extension Input Port Start No.	-1	-1 to 299 1000 to 3999	-	0 + (Multiples of 8) or 1000 + (Multiples of 8) [Ineffective when -1 is selected]
234	(Extension) <sup>(Note 1)</sup> Input Port Start No. at Network I/F Module 2 Fixed Assignment	-1	-1 300 to 599 4000 to 6999	-	300 + (Multiples of 8) or 4000 + (Multiples of 8) [Ineffective when -1 is selected]
235	(Extension) <sup>(Note 1)</sup> Output Port Start No. at Network I/F Module 2 Fixed Assignment	1	0 to 5	-	0: No Monitoring 1: Monitoring * There are some exceptions
237	Network I/F Module 2 Node Address	0	0 to 65535	-	<ul style="list-style-type: none"> <li>At CC-Link : 1 to 64</li> <li>At DeviceNet : 0 to 63</li> <li>At PROFIBUS : 0 to 125</li> <li>At EtherCAT® : 0 to 65535</li> </ul>
238	Network I/F Module 2 Baud Rate	0	0 to 9	-	<ul style="list-style-type: none"> <li>At CC-Link: (0: 156kbps, 1: 625kbps, 2: 2.5Mbps, 3: 5Mbps, 4: 10Mbps)</li> <li>At DeviceNet: (0: 125kbps, 1: 250kbps, 2: 500kbps)</li> <li>At EtherNet/IP: (0: Autonegotiation, 1: 10Mbps (Half-duplex), 2: 10Mbps (Full-duplex), 3: 100Mbps (Half-duplex), 4: 100Mbps (Full-duplex))</li> </ul> <p>* Setting establishment not necessary for PROFIBUS and EtherCAT®</p>

\* The actual default value may differ depending on the construction of used option board.

Note 1: The commands with "Extended" in the parameter name should only be applied for XSEL-R/S.

## [2] I/O Parameter of TTA

No.	Parameter Name	Default (reference)	Input Range	Unit	Remarks
1	I/O Port Allocation Type	0	For reference only	-	0: Fixed Allocation
2	I/O1 Fix-Allocated Input Port Start No.	0	-1 to 299	-	0 + (Multiples of 8) [Ineffective when -1 is selected]
3	I/O1 Fix-Allocated Output Port Start No.	300	-1 300 to 599	-	300 + (Multiples of 8) [Ineffective when -1 is selected]
10	Standard I/O Error Monitoring	1	0 to 5	-	0: No Monitoring (Not to use I/O board) 1: Monitoring 2: Monitoring (Not to monitor 24V I/O power related error) 3: Monitoring (To monitor only 24V I/O power related error)
14	I/O2 Fieldbus Number of Remote Input Ports	0	0 to 240	-	Multiples of 8
15	I/O2 Fieldbus Number of Remote Output Ports	0	0 to 240	-	Multiples of 8
16	I/O2 Fix-Allocated Input Port Start No.	-1	-1 to 299	-	0 + (Multiples of 8) (0 to 299) (Unavailable when it is negative figure)
17	I/O2 Fix-Allocated Output Port Start No.	-1	-1 300 to 599	-	300 + (Multiples of 8) (300 to 599) (Unavailable when it is negative figure)
18	I/O2 Error Monitoring	1	0 to 5	-	0: No Monitoring 1: Monitoring * There are some exceptions
120	Network Attribute 1	640001 <sub>H</sub>	0 <sub>H</sub> to FFFFFFF <sub>H</sub>	-	Bit 0 to 3 : System Reservation Bit 4 to 11 : I/O2 Fieldbus Link Error Check Timer Value (10ms) Bit 12 to 15 : For Future Extension Bit 16 to 27 : Value of Link Timeout at Initializing (100ms) Bit 24 to 27 : System Reservation Bit 28 to 31 : I/O2 Fieldbus Link Error/Input Port Data Select at PIO Power Supply Error (0: Clear, 1: Hold)
121	Network Attribute 2	C80000 <sub>H</sub>	0 to FFFFFFF <sub>H</sub>	-	Bit 0 to 7 : System Reservation Bit 8 to 11 : I/O3 Fieldbus Link Error/Input Port Data Select at PIO Power Supply Error (0: Clear, 1: Hold) Bit 12 to 15 : For Future Extension Bit 16 to 27 : Network Link timeout value at initializing (100ms) Bit 28 to 31 : EtherCAT <sup>®</sup> PDO Mapping Type (0: Variable, 1: Fixed at 32 bytes)
225	Extension I/O Control	*6 <sub>H</sub> 6* <sub>H</sub>	For reference only (HEX)	-	Bit 0 to 3 : I/O2 Module Type Bit 4 to 7 : I/O3 Module Type (0h: Not Mounted, 1h: CC-Link, 2h: DeviceNet, 3h: PROFIBUS, 4h to 5h: System Reservation, 6h: EtherCAT <sup>®</sup> , 7h: EtherNet/IP, 8h: System Reservation, 9h: PIO)
226	I/O2 Fieldbus Node Address	0	0 to 65535	-	• At CC-Link : 1 to 64 • At DeviceNet : 0 to 63 • At PROFIBUS : 0 to 125 • At EtherCAT <sup>®</sup> : 0 to 65535

No.	Parameter Name	Default (reference)	Input Range	Unit	Remarks
227	I/O2 Fieldbus Baud Rate	0	0 to 9	-	<ul style="list-style-type: none"> <li>At CC-Link: (0: 156kbps, 1: 625kbps, 2: 2.5Mbps, 3: 5Mbps, 4: 10Mbps)</li> <li>At DeviceNet: (0: 125kbps, 1: 250kbps, 2: 500kbps, 3: Automatically)</li> <li>At EtherNet/IP: (0: Autonegotiation, 1: 10Mbps (Half-duplex), 2: 10Mbps (Full-duplex), 3: 100Mbps (Half-duplex), 4: 100Mbps (Full-duplex))</li> </ul> * Setting establishment not necessary for PROFIBUS and EtherCAT®
231	I/O3 Fieldbus Number of Remote Input Ports	0	0 to 240	-	Multiples of 8
232	I/O3 Fieldbus Number of Remote Output Ports	0	0 to 240	-	Multiples of 8
233	I/O3 Fix-Allocated Input Port Start No.	-1	-1 to 299	-	0 + (Multiples of 8) (0 to 299) [Ineffective when -1 is selected]
234	I/O3 Fix-Allocated Output Port Start No.	-1	-1 300 to 599	-	300 + (Multiples of 8) (300 to 599) [Ineffective when -1 is selected]
235	I/O3 Error Monitoring	1	0 to 5	-	0: No Monitoring 1: Monitoring * There are some exceptions
237	I/O3 Fieldbus Node Address	0	0 to 65535	-	<ul style="list-style-type: none"> <li>At CC-Link : 1 to 64</li> <li>At DeviceNet : 0 to 63</li> <li>At PROFIBUS : 0 to 125</li> <li>At EtherCAT® : 0 to 65535</li> </ul>
238	I/O3 Fieldbus Baud Rate	0	0 to 9	-	<ul style="list-style-type: none"> <li>At CC-Link: (0: 156kbps, 1: 625kbps, 2: 2.5Mbps, 3: 5Mbps, 4: 10Mbps)</li> <li>At DeviceNet: (0: 125kbps, 1: 250kbps, 2: 500kbps, 3: Automatically)</li> <li>At EtherNet/IP: (0: Autonegotiation, 1: 10Mbps (Half-duplex), 2: 10Mbps (Full-duplex), 3: 100Mbps (Half-duplex), 4: 100Mbps (Full-duplex))</li> </ul> * Setting establishment not necessary for PROFIBUS and EtherCAT®

\* The actual default value may differ depending on the construction of used option board.

## [3] I/O Parameter of MSEL

No.	Parameter Name	Default (reference)	Input Range	Unit	Remarks
1	I/O Port Allocation Type	0	For reference only	-	0: Fixed Allocation
14	I/O2 Fieldbus Number of Remote Input Ports	0	0 to 240	-	Multiples of 8
15	I/O2 Fieldbus Number of Remote Output Ports	0	0 to 240	-	Multiples of 8
16	I/O2 Fix-Allocated Input Port Start No.	-1	-1 to 299	-	0 + (Multiples of 8) (0 to 299) (Unavailable when it is negative figure)
17	I/O2 Fix-Allocated Output Port Start No.	-1	-1 300 to 599	-	300 + (Multiples of 8) (300 to 599) (Unavailable when it is negative figure)
18	I/O2 Error Monitoring	1	0 to 5	-	0: No Monitoring 1: Monitoring * There are some exceptions
120	Network Attribute 1	1 <sub>H</sub>	0 <sub>H</sub> to FFFFFF <sub>H</sub>	-	Bit 0 to 3 : System Reservation Bit 4 to 11 : I/O2 Fieldbus Link Error Check Timer Value (10ms) Bit 24 to 27 : System Reservation Bit 28 to 31 : I/O2 Fieldbus Link Error/Input Port Data Select at PIO Power Supply Error (0: Clear, 1: Hold)
121	Network Attribute 2	C8000 <sub>H</sub>	0 to FFFFFF <sub>H</sub>	-	Bit 0 to 15 : System Reservation Bit 16 to 27 : Network Link Timeout Value at Initializing (100ms) Bit 28 to 31 : EtherCAT® PDO Mapping Type (0: Variable, 1: Fixed at 32 bytes)
225	Extension I/O Control	*6 <sub>H</sub>	For reference only (HEX)	-	Bit 0 to 3 : I/O2 Module Type (0h: Not Mounted 1h: CC-Link, 2h: DeviceNet, 3h: PROFIBUS, 4h to 5h: System Reservation, 6h: EtherCAT®, 7h: EtherNet/IP, 8h: System Reservation, 9h: PIO, A : PROFINET IO (Main Application V2.00 or later), B : System Reservation, C : Extension SIO (Main Application V2.00 or later), D to F : System Reservation)
226	I/O2 Fieldbus Node Address	0	0 to 65535	-	• At CC-Link : 1 to 64 • At DeviceNet : 0 to 63 • At PROFIBUS : 0 to 125 • At EtherCAT®: 0 to 65535
227	I/O2 Fieldbus Baud Rate	0	0 to 9	-	• At CC-Link : (0 to 4) • At DeviceNet : (0 to 3) • At EtherNet/IP : (0 to 4) * Setting establishment not necessary for PROFIBUS, EtherCAT® and PROFINET

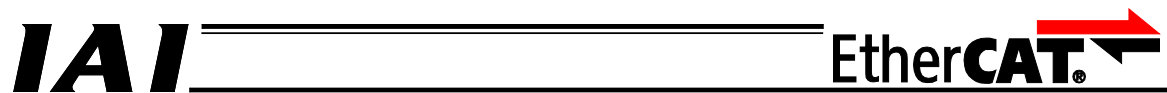

## 6.3 Network Setting File

It is necessary to use network setting file dedicated for controller. Please download from Download Support Page in IAI homepage.

## 6.4 Example for Connectivity Setting

### EtherCAT® Master (NJ Series) Connectivity Setting

Here describes the specifications of SEL controller EtherCAT® type and the connectivity setting to the EtherCAT® master manufactured by Omron (NJ series).

#### 6.4.1 Sysmac Studio Startup and PLC Communication Connectivity

- 1 Double-click "Sysmac Studio" icon to launch the software.
- 2 Click "Connect to Device".

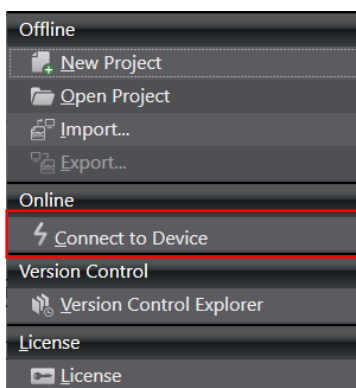

- 3 Connect to Device window shows up.  
Select "Direct connection via USB" in "Connection type". Also, remove the checkmarks on "Transfer from Device." and "Display the Troubleshooting Dialog Box." in "Operation after Connection".  
Click Connect.

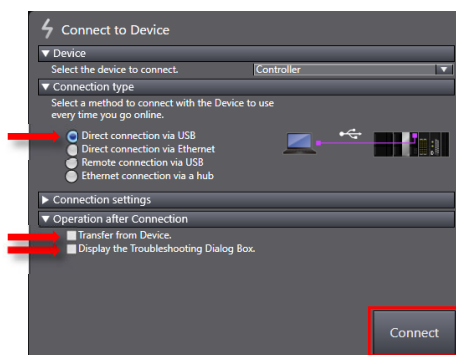

- 4 Complete dialog appears. Click **OK**.

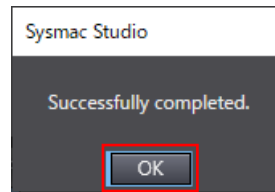

- 5 Auto Connect Project window should get displayed online. Once it gets online, a yellow frame should appear at the top in "Edit Window".

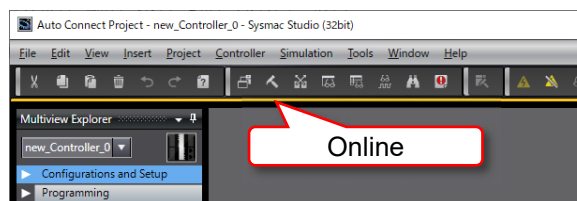

## 6.4.2 Installing Setting File for Network (ESI File)

- 1 From the menu bar in Auto Connect Project window, click "Controller" → "Offline" to set the status offline.

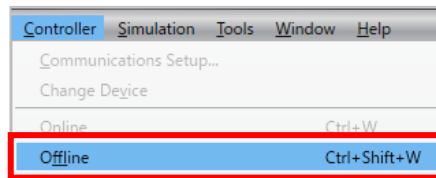

- 2 In Auto Connect Project window, click **Configurations and Setup** from "Multiview Explorer".

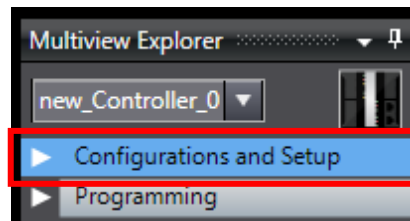

- 3 Double-click "EtherCAT" in "Configurations and Setup".

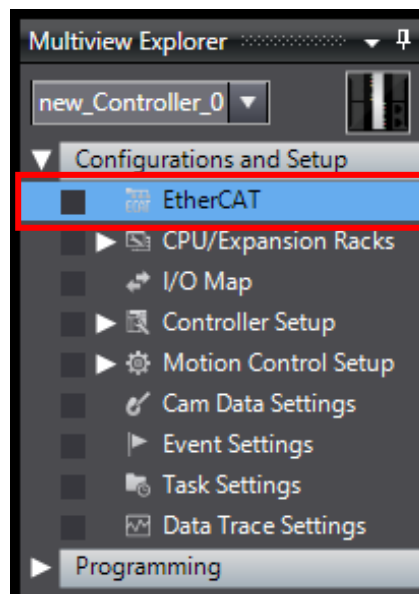

- 4 EtherCAT window should be shown in "Edit Window".

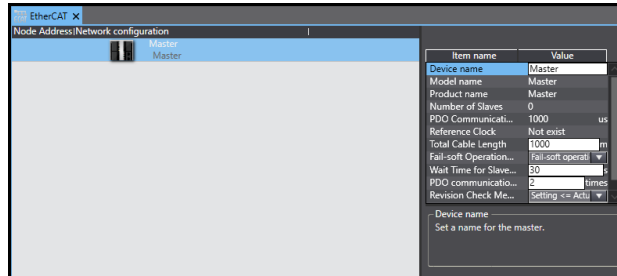

- 5 Right-click "Master" and select "Display ESI Library".

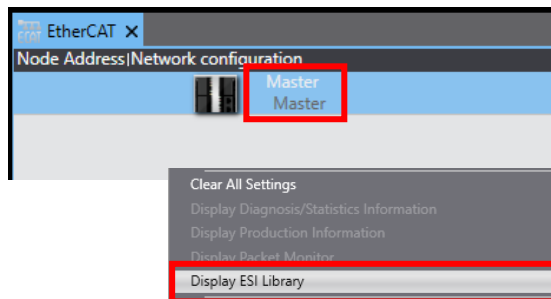

- 6 Click **Install (File)** in ESI Library window.

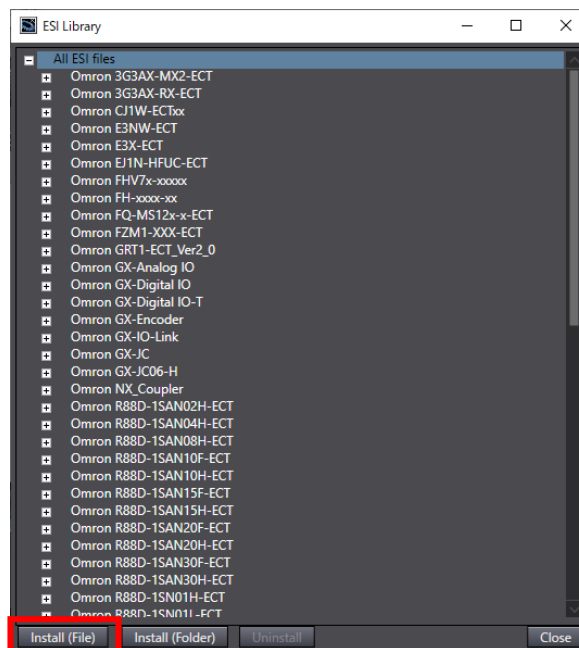

- 7 Select the ESI file that was downloaded from the IAI homepage and click **Open**.

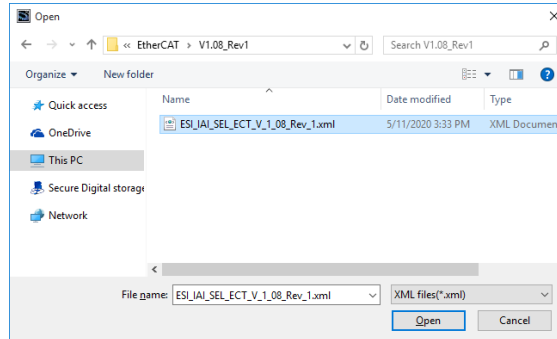

- 8 "Execute Installation" dialog should appear. Confirm the content and click **Yes**.

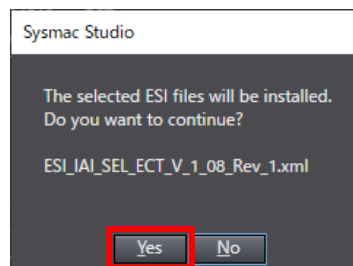

- 9 "Installation Complete" dialog should appear. Click **OK**.

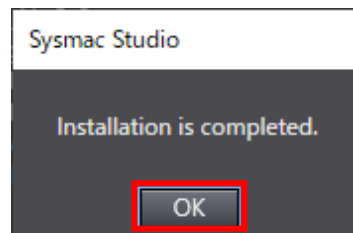

- 10 The installed ESI file should get added in ESI Library window. Click the plus icon to confirm that devices get displayed.

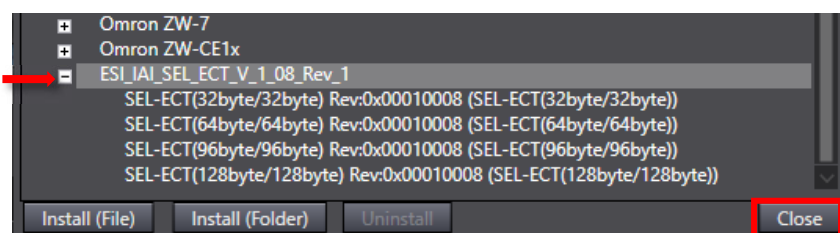

Click **Close**.

## 6.4.3 Setup of EtherCAT Network Configuration

### [1] How to Set up Online (Merge Actual Network Configuration)

- 1 In "EtherCAT" tab in Auto Connect Project window, right-click "Master".

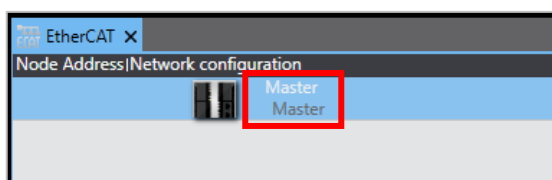

- 2 Click **Compare and Merge with Actual Network Configuration**.

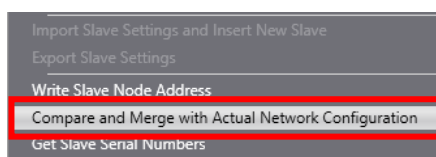

- 3 Click **Apply actual network configuration**.

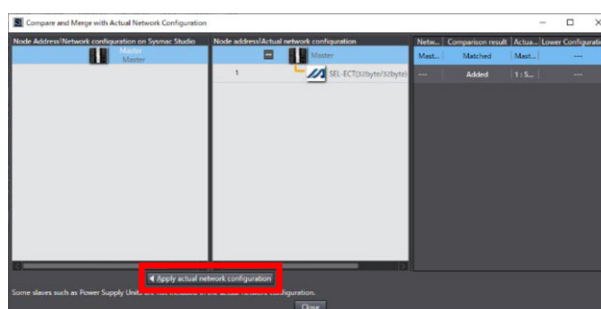

- 4 Apply actual network configuration window should appear. Confirm the content and click **Apply**.

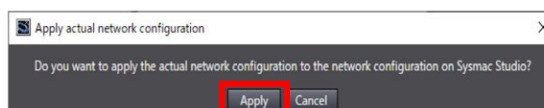

Once the execution result gets displayed, click **Close**.

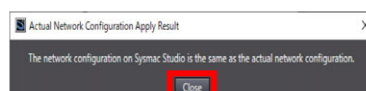

- 5 The slave should be added to "Network configuration on Sysmac Studio" in Compare and Merge with Actual Network Configuration window. Confirm that it is added and click Close.

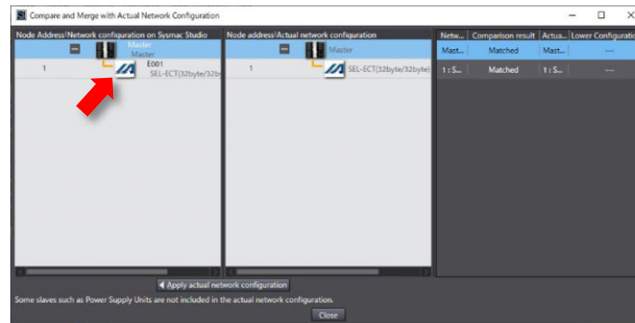

- 6 The slave should be added in "EtherCAT" tab in Auto Connect Project window.

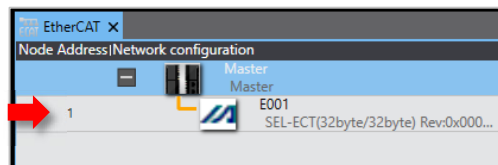

[2] How to Set up Offline (To be selected from the tool box)

- 1 Click "SEL Controller" from "Groups" in "Toolbox" in Auto Connect Project window.

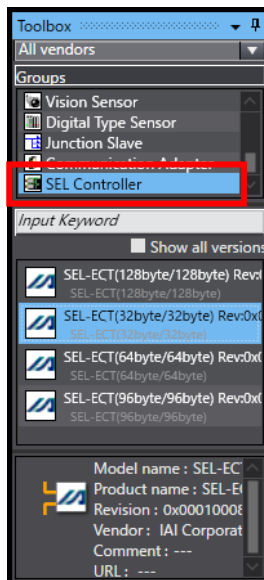

- 2 Double-click the applicable device in the list at the bottom of "Toolbox", or drag & drop to "Master" in "EtherCAT" tab. Select the applicable device referring to the number of used EtherCAT input and output ports.

Number of Used EtherCAT Input and Output Ports	ESI File Applicable Device
8 to 256	SEL-ECT (32bytes/32bytes)

\* As the applicable device should differ depending on the number of ports used for input and output, a device with larger number of ports should be applied.

- 3 The slave should be added in "EtherCAT" tab in Auto Connect Project window.

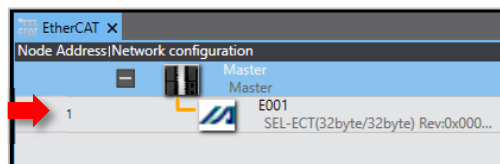

- 4 When the node address of the slave is to be assigned fixed (SEL controller I/O Parameter No. 226 = 1 to 65535), select Slave in "EtherCAT" tab and change "Node Address" in the parameter setting window so it matches with the value in I/O Parameter No. 226 of SEL Controller.

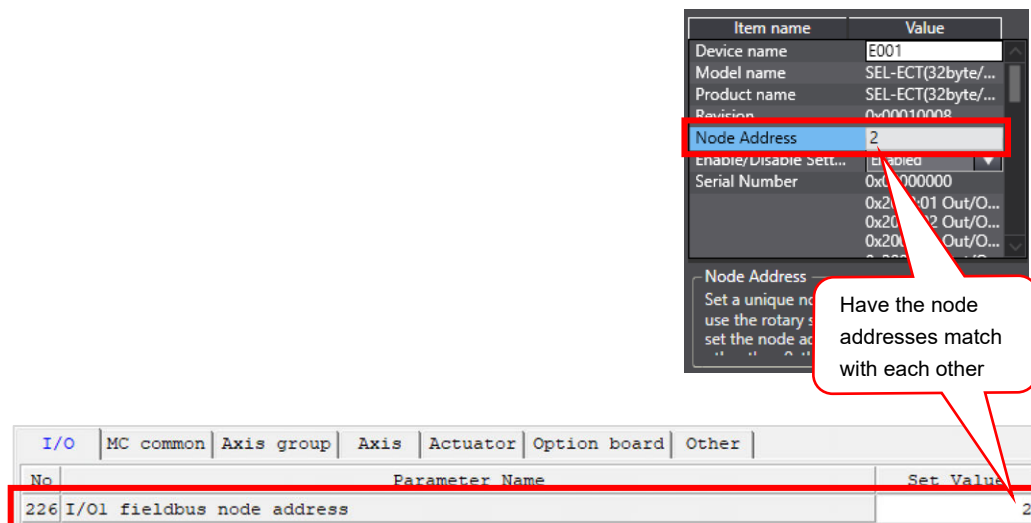

- 5 The node address of the slave in "EtherCAT" tab in Auto Connect Project window should be updated.

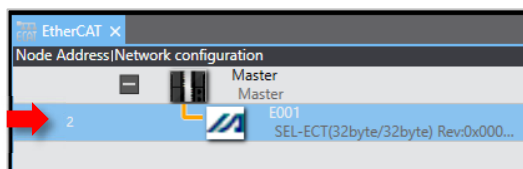

## 6.4.4 Changing PDO Mapping Setting

For the controllers with their setting in Parameter No. 121 "Network Atrbt2" Bits 28-31 "EtherCAT PDO Mapping Classification" = 0 (Variable), it is necessary to match the input and output settings in the master and slave.

No.	Parameter Name	Set. Value
121	Network Atrbt2	C80000h

Bits 28-31 = 0  
(will not be shown upper 4 bits are 0)

- 1 Confirm that it is in the state of PLC and offline.  
If it is online, click "Contr<sup>o</sup>ller" → "Offline" from the menu bar in Auto Connect Project window to set it offline.

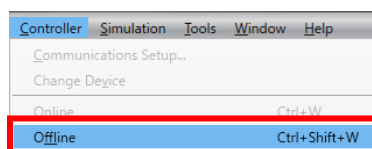

- 2 Select a slave subject to the change of PDO mapping setting in "EtherCAT" tab, and click Edit PDO Map Settings in the parameter setting window.

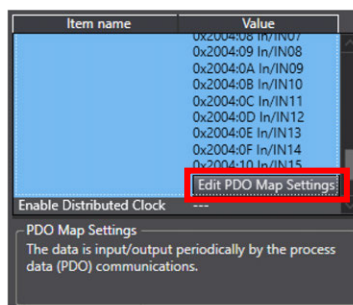

**3** Edit the process data size of input and output in "Edit PDO Map Settings" window.

- When the input of the process data size do not match with the setting in I/O Parameter No. 15 "Number of ports used for I/O1 fieldbus remote output" of controller.

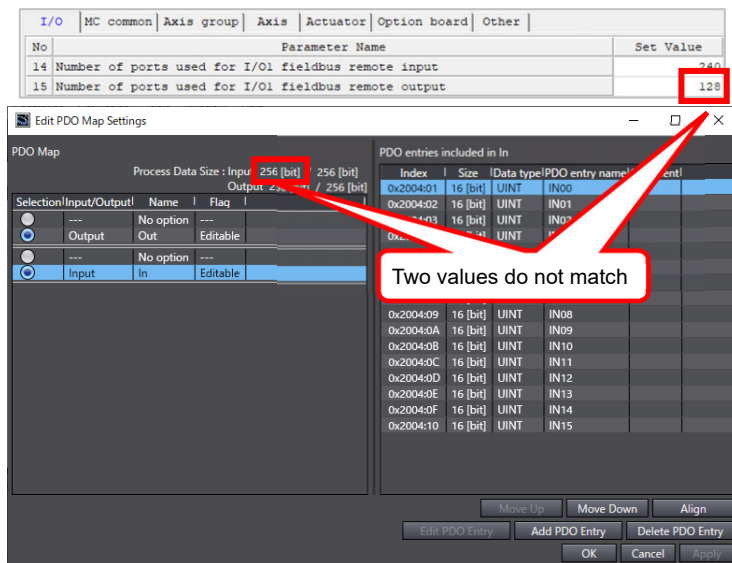

- (1) Select "Input" from the PDO mapping list, and delete the PDO entries till the input of the process data size matches with I/O Parameter No. 15 "Number of ports used for I/O1 fieldbus remote output" in SEL Controller. Select the PDO entries in the descending order of the index from "PDO entries included in In", and click Delete PDO Entry.

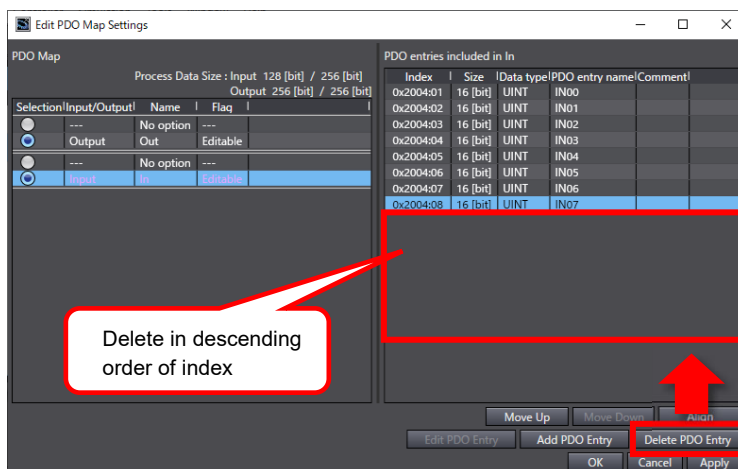

- (2) Once the input of the process data size matches with I/O Parameter No. 15 "Number of ports used for I/O1 fieldbus remote output" in SEL Controller, click **Apply**.

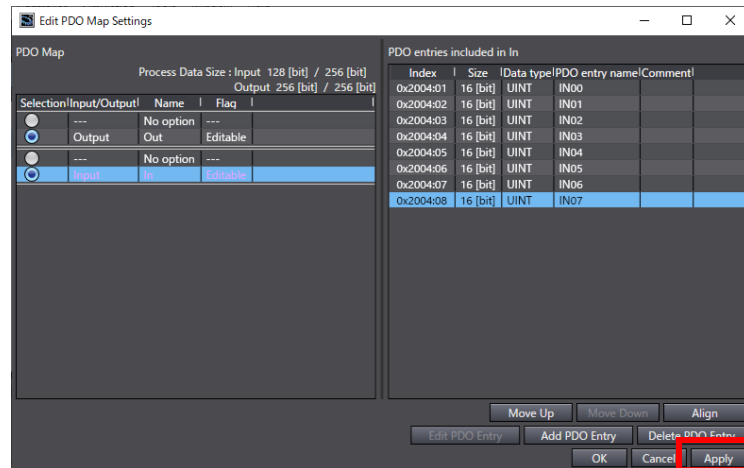

- When the output of the process data size do not match with the setting in I/O Parameter No. 14 "Number of ports used for I/O1 fieldbus remote input" of controller.

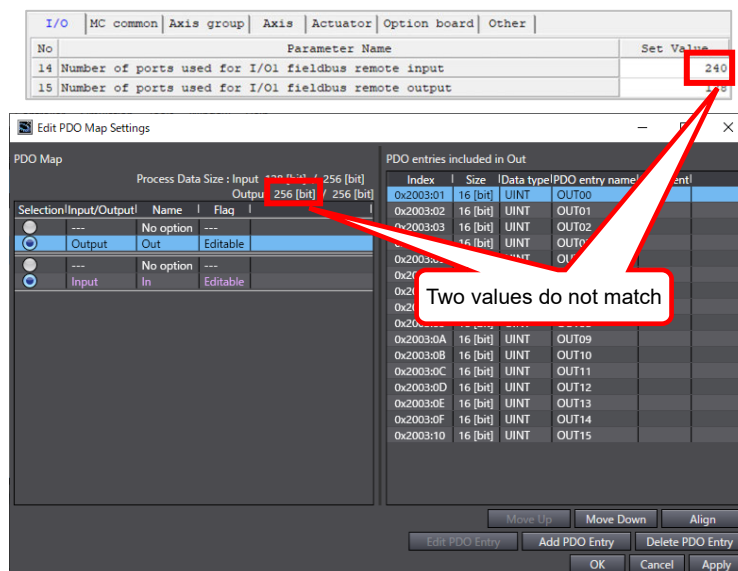

- Select "Output" from the PDO mapping list, and delete the PDO entries till the output of the process data size matches with I/O Parameter No. 14 " Number of ports used for I/O1 fieldbus remote input " in Controller. Select the PDO entries in the descending order of the index from "PDO entries included in Out", and click Delete PDO Entry.

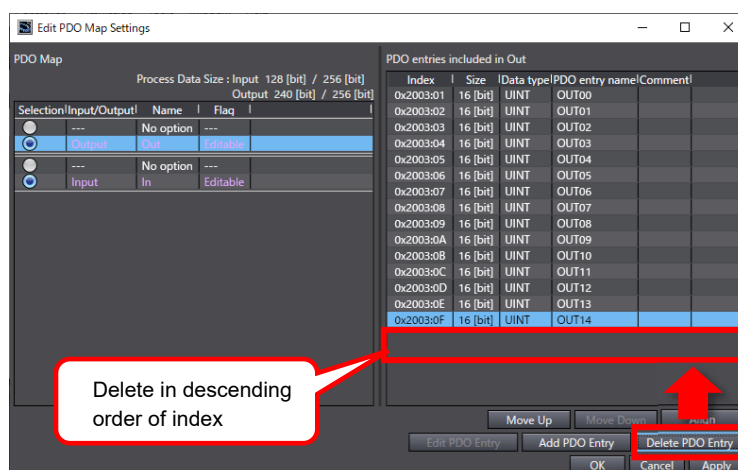

- (2) Once the input of the process data size matches with I/O Parameter No. 14 "Number of ports used for I/O1 fieldbus remote input" in SEL Controller, click **Apply**.

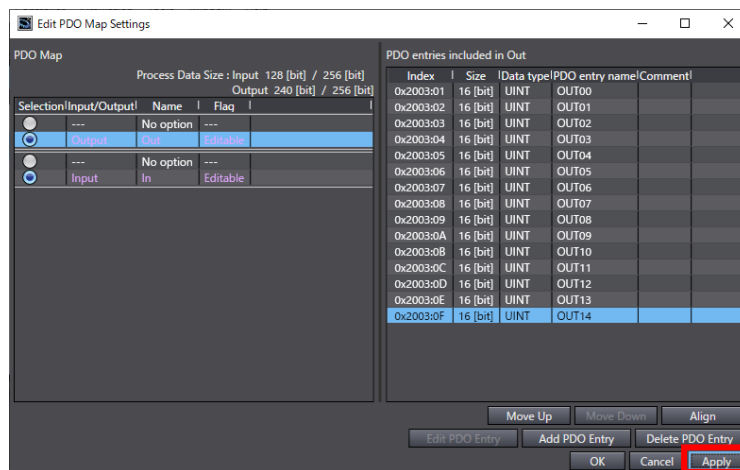

Once the process data size in both the input and the output matches with the number of used ports in the slave, click **OK** to finish the edit.

## 6.4.5 Data Transfer to PLC

- 1 Confirm that it is in the state of PLC and online. If it is online, a yellow frame should be displayed at the top in "Edit Window".

If it is offline, click "Controller" → "Online" from the menu bar in Auto Connect Project window to set it online.

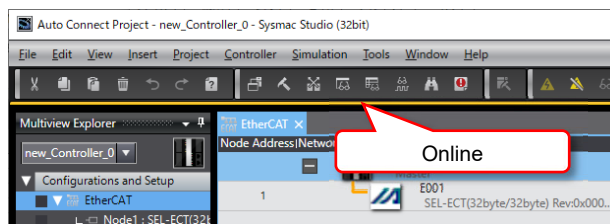

- 2 Click "Controller" → "Synchronize..." from the menu bar in Auto Connect Project window.

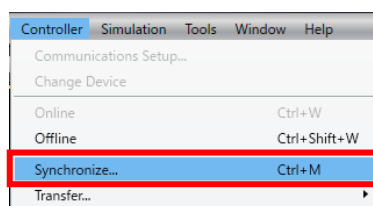

- 3 Synchronization window should appear. Put a checkmark on the data subject to transfer.

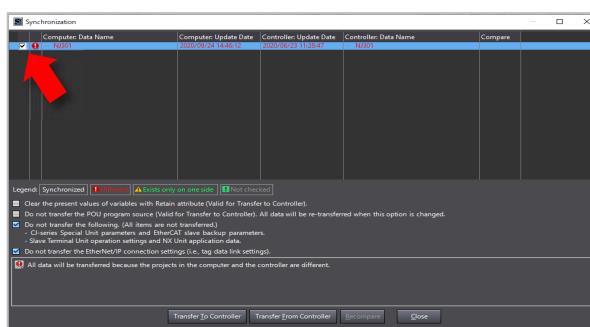

- 4 Click **Transfer To Controller**.

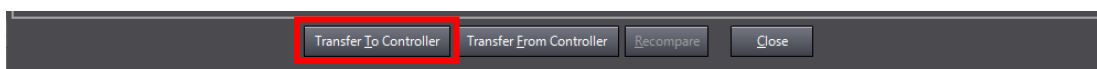

- 5 As the Transfer execution confirmation window appears, confirm that there is no problem if PLC operation stops, and click **Yes**.

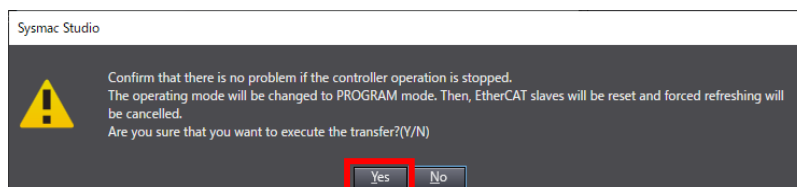

- 6 As the Operation mode change confirmation window appears, confirm that there is no problem if PLC operation stops, and click **Yes**.

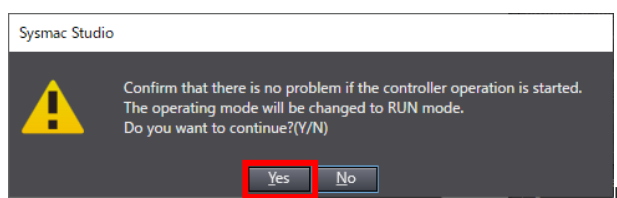

- 7 Confirm that "Synchronization" is complete and click **Close**.

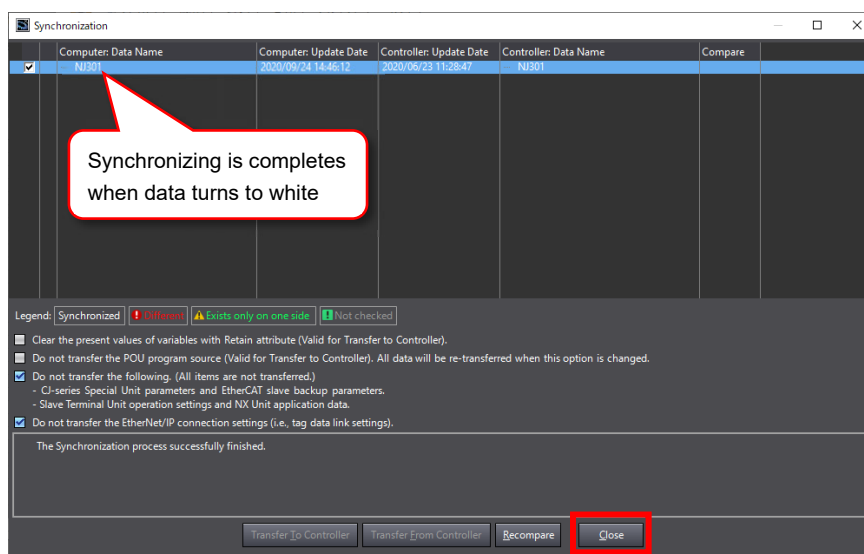

## Change History

Revision Date	Description of Revision
2012.09	First edition
2012.11	Second edition Contents changed in I/O Parameters No.226 (Setting establishment not necessary for node address)
2013.07	Third edition Missing
2015.12	Fourth edition Applicable models added (TTA) Contents revised for description
2016.03	Fifth edition MSEL added
2016.07	Sixth edition XSEL-RA/SA Series added
2018.05	Sixth B edition 4.6, 5.6 Contents revised in delivery setting table for I/O ports on TTA and MSEL
2018.06	Sixth C edition 1. Outline: Descriptions revised 3.2, 4.2 and 5.2: Models added in model codes Parameter No. 1, 120, 121, 225, 233 and 234: Descriptions revised
2021.06	Seventh edition Chapter 1 Overview: Model codes added in List of EtherCAT related instruction manuals (PCON-CBP, RSEL, REC) 3.5.1, 3.5.2: CC-Link IE Field parameters added Appendix: xamples added for connectivity of EtherCAT connection type controller to PLC Unification of terms and expressions throughout this manual
2022.01	Eighth edition Change made to cover page design Description revised for the [Please Read Before Use] Description revised in Safety Guide 1. Overview Added RCON-NCN to the explanation column of controllers other than this manual.







## ***IAI Corporation***

Head Office: 577-1 Obane Shimizu-KU Shizuoka City Shizuoka 424-0103, Japan  
TEL +81-54-364-5105 FAX +81-54-364-2589  
website: [www.iai-robot.co.jp/](http://www.iai-robot.co.jp/)

Technical Support available in USA, Europe and China

## ***IAI America, Inc.***

Head Office: 2690 W. 237th Street, Torrance, CA 90505  
TEL (310) 891-6015 FAX (310) 891-0815  
Chicago Office: 110 East State Parkway, Schaumburg, IL 60173  
TEL(847) 908-1400 FAX (847) 908-1399  
Atlanta Office: 1220 Kennestone Circle, Suite 108, Marietta, GA 30066  
TEL (678) 354-9470 FAX (678) 354-9471  
website: [www.intelligentactuator.com](http://www.intelligentactuator.com)

## ***IAI Industrieroboter GmbH***

Ober der Röth 4, D-65824 Schwalbach am Taunus, Germany  
TEL 06196-88950 FAX 06196-889524  
website:[www.iai-automation.com](http://www.iai-automation.com)

## ***IAI (Shanghai) Co., Ltd.***

SHANGHAI JIAHUA BUSINESS CENTER A8-303, 808, Hongqiao Rd. Shanghai 200030, China  
TEL 021-6448-4753 FAX 021-6448-3992  
website: [www.iai-robot.com](http://www.iai-robot.com)

## ***IAI Robot (Thailand) Co., Ltd.***

825 PhairojKijja Tower 7th Floor, Debaratana RD., Bangna-Nuea, Bangna, Bangkok 10260, Thailand  
TEL +66-2-361-4458 FAX +66-2-361-4456  
website:[www.iai-robot.co.th](http://www.iai-robot.co.th)