

Ethernet

Instruction Manual Seventh Edition *ME0140-7A*



Overview	Chapter 1
Ethernet Interface Specifications	Chapter 2
Wiring of Ethernet	Chapter 3
Ethernet Communication Setting	Chapter 4
IAI Protocol B/TCP	Chapter 5
Transmission by SEL Program	Chapter 6
Remote I/O (Modbus/TCP)	Chapter 7
Appendix	Chapter 8

Please Read Before Use

Thank you for purchasing our product.

This instruction manual explains the handling methods, structure and maintenance of this product, providing the information you need in order to use the product safely.

Before using the product, be sure to read this manual and fully understand the contents explained herein to ensure safe use of the product.

Please download the user's manual from our website.

You can download it free of charge. User registration is required for the first time downloading.

URL: www.iai-robot.co.jp/data_dl/CAD_MANUAL/

When using the product, print out of the necessary portions of the relevant manual, or please display it on your computer, tablet terminal, etc. so that you can check it immediately.

After reading the instruction manual, keep it in a convenient place so that whoever is handling the product can refer to it quickly when necessary.

[Important]

- This instruction manual is an original document dedicated for this product.
- This product cannot be used in ways not shown in this instruction manual. IAI shall not be liable for any result whatsoever arising from the use of the product in any other way than what is noted in the manual.
- The information contained in this instruction manual is subject to change without notice for the purpose of product improvement.
- If any issues arise regarding the information contained in this instruction manual, contact our customer center or the nearest sales office.
- Use or reproduction of this instruction manual in full or in part without permission is prohibited.
- The company names, names of products and trademarks of each company shown in the text are registered trademarks.

Ethernet Instruction Manual Configuration

Product name	Instruction manual name	Control number
Ethernet Connection	Ethernet Instruction Manual (This manual)	ME0140
EtherNet/IP Connection	EtherNet/IP Instruction Manual Programming Type Controller Edition	ME0308
XSEL2	XSEL2 Instruction Manual	ME0478
RSEL	RSEL Instruction Manual	ME0392
XSEL-RA/SA/RAX/SAX/RAXD/SAXD	XSEL-RA/SA/RAX/SAX/RAXD/SAXD Instruction Manual	ME0359
MSEL	MSEL Instruction Manual	ME0336
TTA	TTA Instruction Manual	ME0320
XSEL-R_S_RX_SX_RXD_SXD	XSEL-R_S_RX_SX_RXD_SXD Instruction Manual	ME0313
SSEL	SSEL Instruction Manual	ME0157
ASEL	ASEL Instruction Manual	ME0165
PSEL	PSEL Instruction Manual	ME0172
XSEL-P_Q	XSEL-P_Q Instruction Manual	ME0148
XSEL-PX_QX	XSEL-PX_QX Instruction Manual	ME0152
XSEL-J_K	XSEL-J_K Instruction Manual	ME0116
XSEL-JX_KX	XSEL-JX_KX Instruction Manual	ME0119
XSEL-KT_KET	XSEL-KT_KET Instruction Manual	ME0134
TT	TT Instruction Manual	ME0149
SEL language	SEL Language Programming Manual	ME0224
PC Software	PC Software for XSEL Instruction Manual	ME0154
PC Software	PC Software for XSEL Instruction Manual RSEL Edition	ME0398
Touch Panel Teaching Pendant TB-01	TB-01/01D/01DR Applicable for Program Controller Instruction Manual	ME0325
Touch Panel Teaching Pendant TB-02	TB-02/02D Applicable for Program Controller Instruction Manual	ME0356
Touch Panel Teaching Pendant TB-03	TB-03 Program Controller Wired Link Instruction Manual	ME0377

Contents

Safety Guide	Intro-1
Precautions for Handling	Intro-8

Chapter 1 Overview

1.1 Ethernet Communication of Program Controller	1-1
1.2 Characteristics	1-2
1.2.1 Communication / Control of Ethernet	1-2
1.2.2 Transmission by SEL Program (4 channels)	1-3
1.3 Functional Systems of Ethernet	1-4
1.4 Applicable Model List for Ethernet Communication Features	1-5

Chapter 2 Ethernet Interface Specifications

2.1 Standard Ethernet Port for XSEL2	2-1
2.1.1 Name of Each Part	2-1
2.1.2 Network Specification	2-1
2.1.3 Monitor LED Indications	2-2
2.2 Standard Ethernet Port for XSEL-RA/SA/RAX/SAX/RAXD/SAXD	2-3
2.2.1 Name of Each Part	2-3
2.2.2 Network Specification	2-3
2.2.3 Monitor LED Indications	2-4
2.3 Standard Ethernet Port for RSEL (SEL unit)	2-5
2.3.1 Name of Each Part	2-5
2.3.2 Network Specification	2-5
2.3.3 Monitor LED Indications	2-6
2.4 XSEL-R/S/RX/SX/RXD/SXD	2-7
2.4.1 Model Codes and Name of Each Part	2-7
2.4.2 Network Specification	2-8
2.4.3 Monitor LED Indications	2-9
2.5 TTA Ethernet	2-10
2.5.1 Model Codes and Name of Each Part	2-10
2.5.2 Network Specification	2-11
2.5.3 Monitor LED Indications	2-12
2.6 MSEL Ethernet	2-13
2.6.1 Name of Each Part	2-13
2.6.2 Network Specification	2-14

2.6.3	Monitor LED Indications	2-15
2.7	ASEL/PSEL/SSEL Ethernet.....	2-16
2.7.1	Name of Each Part.....	2-16
2.7.2	Network Specification	2-17
2.7.3	Monitor LED Indications	2-18
2.8	XSEL-J/K/JX/KX/P/Q/PX/QX Interface Board (Option)	2-19
2.8.1	Name of Each Part.....	2-19
2.8.2	Network Specification	2-20
2.8.3	Monitor LED Indications	2-21

Chapter 3 Wiring for Ethernet

3.1	Wiring Example	3-1
3.2	Pin Assignment in Ethernet Connector.....	3-2

Chapter 4 Ethernet Communication Setting

4.1	XSEL2, XSEL-RA/SA/RAX/SAX/RAXD/SAXD and RSEL System (SEL unit).....	4-1
4.1.1	Ethernet Environment Setting of Self Station	4-1
4.1.2	How to Check Communication and Operation.....	4-3
4.1.3	Related Parameters	4-4
4.2	XSEL-R/S/RX/SX/RXD/SXD, TTA, MSEL, ASEL/PSEL/SSEL Ethernet.....	4-7
4.2.1	Ethernet Environment Setting of Self Station	4-7
4.2.2	How to Check Communication and Operation.....	4-11
4.2.3	Related Parameters	4-12
4.3	XSEL-J/K/KT/KET/JX/KX/KXT/P/Q/PX/QX	4-15
4.3.1	Ethernet Environment Setting of Self Station	4-15
4.3.2	How to Check Communication and Operation.....	4-17
4.3.3	Related Parameters	4-18
4.4	Feature Setting Related to Communication.....	4-21
4.4.1	Keep-Alive Feature Setting	4-21
4.4.2	Serial Communication Multiple Channels Applicable Feature	4-22
4.5	Check Ping Response from PC.....	4-24

Chapter 5 IAI Protocol B/TCP

5.1	What is IAI Protocol B/TCP	5-1
5.2	Ethernet Connection of XSEL PC Software.....	5-2
5.2.1	Software Versions Supporting This Function	5-2

5.2.2	Items to Note	5-3
5.2.3	When Using PC (XSEL PC software) as Sever	5-4
5.2.4	When Using PC (XSEL PC Software) as Client	5-11
5.3	How to Check Operation of IAI Protocol B/TCP by Telnet Client	5-17

Chapter 6 Transmission by SEL Program

6.1	Setup of Ethernet Environment	6-2
6.2	Related Parameters I/O Parameters	6-3
6.2.1	Standard Ethernet Port for XSEL-RA/SA/RAX/SAX/RAXD/SAXD and RSEL System (SEL unit)	6-3
6.2.2	XSEL-J/K/JX/KX/P/Q/PX/QX Interface Board (Option)	6-4
6.3	Message Communication with SEL Program (Non-Procedure Communication)	6-6
6.3.1	List of SEL Commands	6-6
6.3.2	Details of SEL Commands	6-7

Chapter 7 Remote I/O (Modbus/TCP)

7.1	Setup of Communication Environment	7-2
7.2	Remote I/O Setup Procedure	7-4
7.2.1	Configuration with Modbus/TCP Only (No expansion I/O board)	7-4
7.2.2	Combined Use of Expansion I/O Board (Modbus/TCP + Expanded I/O)	7-6
7.3	Setup Procedure for Exception Status Support	7-8
7.4	Correspondence of Modbus/TCP Address and XSEL I/O	7-9
7.4.1	Little Endian Operation	7-10
7.4.2	Big Endian Operation	7-13
7.5	Installation to a Modbus/TCP System	7-16

Chapter 8 Appendix

8.1	List of Related Alarms	8-1
8.2	ASCII Code List	8-5

Revision History	Post-1
------------------------	--------

Safety Guide

“Safety Guide” has been written to use the machine safely and so prevent personal injury or property damage beforehand. Make sure to read it before the operation of this product.

Safety Precautions for Our Products

The common safety precautions for the use of any of our robots in each operation.

No.	Operation Description	Description
1	Model Selection	<ul style="list-style-type: none"> ● This product has not been planned and designed for the application where high level of safety is required, so the guarantee of the protection of human life is impossible. Accordingly, do not use it in any of the following applications. <ol style="list-style-type: none"> 1) Medical equipment used to maintain, control or otherwise affect human life or physical health. 2) Mechanisms and machinery designed for the purpose of moving or transporting people (For vehicle, railway facility or air navigation facility) 3) Important safety parts of machinery (Safety device, etc.) ● Do not use the product outside the specifications. Failure to do so may considerably shorten the life of the product. ● Do not use it in any of the following environments. <ol style="list-style-type: none"> 1) Location where there is any inflammable gas, inflammable object or explosive 2) Place with potential exposure to radiation 3) Location with the ambient temperature or relative humidity exceeding the specification range 4) Location where radiant heat is added from direct sunlight or other large heat source 5) Location where condensation occurs due to abrupt temperature changes 6) Location where there is any corrosive gas (sulfuric acid or hydrochloric acid) 7) Location exposed to significant amount of dust, salt or iron powder 8) Location subject to direct vibration or impact ● For an actuator used in vertical orientation, select a model which is equipped with a brake. If selecting a model with no brake, the moving part may drop when the power is turned OFF and may cause an accident such as an injury or damage on the work piece.

No.	Operation Description	Description
2	Transportation	<ul style="list-style-type: none"> ● When carrying a heavy object, do the work with two or more persons or utilize equipment such as crane. ● When the work is carried out with 2 or more persons, make it clear who is to be the “leader” and who to be the “follower(s)” and communicate well with each other to ensure the safety of the workers. ● When in transportation, consider well about the positions to hold, weight and weight balance and pay special attention to the carried object so it would not get hit or dropped. ● Transport it using an appropriate transportation measure. The actuators available for transportation with a crane have eyebolts attached or there are tapped holes to attach bolts. Follow the instructions in the instruction manual for each model. ● Do not step or sit on the package. ● Do not put any heavy thing that can deform the package, on it. ● When using a crane capable of 1t or more of weight, have an operator who has qualifications for crane operation and sling work. ● When using a crane or equivalent equipments, make sure not to hang a load that weighs more than the equipment’s capability limit. ● Use a hook that is suitable for the load. Consider the safety factor of the hook in such factors as shear strength. ● Do not get on the load that is hung on a crane. ● Do not leave a load hung up with a crane. ● Do not stand under the load that is hung up with a crane.
3	Storage and Preservation	<ul style="list-style-type: none"> ● The storage and preservation environment conforms to the installation environment. However, especially give consideration to the prevention of condensation. ● Store the products with a consideration not to fall them over or drop due to an act of God such as earthquake.
4	Installation and Start	<p>(1) Installation of Robot Main Body and Controller, etc.</p> <ul style="list-style-type: none"> ● Make sure to securely hold and fix the product (including the work part). A fall, drop or abnormal motion of the product may cause a damage or injury. Also, be equipped for a fall-over or drop due to an act of God such as earthquake. ● Do not get on or put anything on the product. Failure to do so may cause an accidental fall, injury or damage to the product due to a drop of anything, malfunction of the product, performance degradation, or shortening of its life. ● When using the product in any of the places specified below, provide a sufficient shield. <ol style="list-style-type: none"> 1) Location where electric noise is generated 2) Location where high electrical or magnetic field is present 3) Location with the mains or power lines passing nearby 4) Location where the product may come in contact with water, oil or chemical droplets

No.	Operation Description	Description
4	Installation and Start	<p>(2) Cable Wiring</p> <ul style="list-style-type: none"> ● Use our company's genuine cables for connecting between the actuator and controller, and for the teaching tool. ● Do not scratch on the cable. Do not bend it forcibly. Do not pull it. Do not coil it around. Do not insert it. Do not put any heavy thing on it. Failure to do so may cause a fire, electric shock or malfunction due to leakage or continuity error. ● Perform the wiring for the product, after turning OFF the power to the unit, so that there is no wiring error. ● When the direct current power (+24V) is connected, take the great care of the directions of positive and negative poles. If the connection direction is not correct, it might cause a fire, product breakdown or malfunction. ● Connect the cable connector securely so that there is no disconnection or looseness. Failure to do so may cause a fire, electric shock or malfunction of the product. ● Never cut and/or reconnect the cables supplied with the product for the purpose of extending or shortening the cable length. Failure to do so may cause the product to malfunction or cause fire. <p>(3) Grounding</p> <ul style="list-style-type: none"> ● The grounding operation should be performed to prevent an electric shock or electrostatic charge, enhance the noise-resistance ability and control the unnecessary electromagnetic radiation. ● For the ground terminal (PE) on the AC power cable of the controller and the grounding plate in the control panel, make sure for grounding work. For security grounding, it is necessary to select an appropriate wire thickness suitable for the load. Perform wiring that satisfies the specifications (electrical equipment standards and criteria). For detail, follow the description in [an instruction manual of each controller or controller built-in actuator]. ● Conduct functional grounding on the FG terminal for a controller supplying 24V DC or a controller built-in type actuator. In order to minimize influence to mechanical operation given by electromagnetic interference (noise) to an electrical device or insulation failure, conduct grounding on a terminal or a conductor that is electrically stable. The reference impedance should be Type D (Former Class 3, ground resistance 100Ω or less).





No.	Operation Description	Description
4	Installation and Start	<p>(4) Safety Measures</p> <ul style="list-style-type: none"> ● When the work is carried out with 2 or more persons, make it clear who is to be the “leader” and who to be the “follower(s)” and communicate well with each other to ensure the safety of the workers. ● When the product is under operation or in the ready mode, take the safety measures (such as the installation of safety and protection fence) so that nobody can enter the area within the robot’s movable range. When the robot under operation is touched, it may result in death or serious injury. ● Make sure to install the emergency stop circuit so that the unit can be stopped immediately in an emergency during the unit operation. ● Take the safety measure not to start up the unit only with the power turning ON. Failure to do so may start up the machine suddenly and cause an injury or damage to the product. ● Take the safety measure not to start up the machine only with the emergency stop cancellation or recovery after the power failure. Failure to do so may result in an electric shock or injury due to unexpected power input. ● When the installation or adjustment operation is to be performed, give clear warnings such as “Under Operation; Do not turn ON the power!” etc. Sudden power input may cause an electric shock or injury. ● Take the measure so that the work part is not dropped in power failure or emergency stop. ● Wear protection gloves, goggle or safety shoes, as necessary, to secure safety. ● Do not insert a finger or object in the openings in the product. Failure to do so may cause an injury, electric shock, damage to the product or fire. ● When releasing the brake on a vertically oriented actuator, exercise precaution not to pinch your hand or damage the work parts with the actuator dropped by gravity.
5	Teaching	<ul style="list-style-type: none"> ● When the work is carried out with 2 or more persons, make it clear who is to be the “leader” and who to be the “follower(s)” and communicate well with each other to ensure the safety of the workers. ● Perform the teaching operation from outside the safety protection fence, if possible. In the case that the operation is to be performed unavoidably inside the safety protection fence, prepare the “Stipulations for the Operation” and make sure that all the workers acknowledge and understand them well. ● When the operation is to be performed inside the safety protection fence, the worker should have an emergency stop switch at hand with him so that the unit can be stopped any time in an emergency. ● When the operation is to be performed inside the safety protection fence, in addition to the workers, arrange a watchman so that the machine can be stopped any time in an emergency. Also, keep watch on the operation so that any third person can not operate the switches carelessly. ● Place a sign “Under Operation” at the position easy to see. ● When releasing the brake on a vertically oriented actuator, exercise precaution not to pinch your hand or damage the work parts with the actuator dropped by gravity. <p>* Safety protection Fence : In the case that there is no safety protection fence, the movable range should be indicated.</p>

No.	Operation Description	Description
6	Trial Operation	<ul style="list-style-type: none"> ● When the work is carried out with 2 or more persons, make it clear who is to be the “leader” and who to be the “follower(s)” and communicate well with each other to ensure the safety of the workers. ● After the teaching or programming operation, perform the check operation one step by one step and then shift to the automatic operation. ● When the check operation is to be performed inside the safety protection fence, perform the check operation using the previously specified work procedure like the teaching operation. ● Make sure to perform the programmed operation check at the safety speed. Failure to do so may result in an accident due to unexpected motion caused by a program error, etc. ● Do not touch the terminal block or any of the various setting switches in the power ON mode. Failure to do so may result in an electric shock or malfunction.
7	Automatic Operation	<ul style="list-style-type: none"> ● Check before starting the automatic operation or rebooting after operation stop that there is nobody in the safety protection fence. ● Before starting automatic operation, make sure that all peripheral equipment is in an automatic-operation-ready state and there is no alarm indication. ● Make sure to operate automatic operation start from outside of the safety protection fence. ● In the case that there is any abnormal heating, smoke, offensive smell, or abnormal noise in the product, immediately stop the machine and turn OFF the power switch. Failure to do so may result in a fire or damage to the product. ● When a power failure occurs, turn OFF the power switch. Failure to do so may cause an injury or damage to the product, due to a sudden motion of the product in the recovery operation from the power failure.

No.	Operation Description	Description
8	Maintenance and Inspection	<ul style="list-style-type: none"> ● When the work is carried out with 2 or more persons, make it clear who is to be the “leader” and who to be the “follower(s)” and communicate well with each other to ensure the safety of the workers. ● Perform the work out of the safety protection fence, if possible. In the case that the operation is to be performed unavoidably inside the safety protection fence, prepare the “Stipulations for the Operation” and make sure that all the workers acknowledge and understand them well. ● When the work is to be performed inside the safety protection fence, basically turn OFF the power switch. ● When the operation is to be performed inside the safety protection fence, the worker should have an emergency stop switch at hand with him so that the unit can be stopped any time in an emergency. ● When the operation is to be performed inside the safety protection fence, in addition to the workers, arrange a watchman so that the machine can be stopped any time in an emergency. Also, keep watch on the operation so that any third person can not operate the switches carelessly. ● Place a sign “Under Operation” at the position easy to see. ● For the grease for the guide or ball screw, use appropriate grease according to the instruction manual for each model. ● Do not perform the dielectric strength test. Failure to do so may result in a damage to the product. ● When releasing the brake on a vertically oriented actuator, exercise precaution not to pinch your hand or damage the work parts with the actuator dropped by gravity. ● The slider or rod may get misaligned OFF the stop position if the servo is turned OFF. Be careful not to get injured or damaged due to an unnecessary operation. ● Pay attention not to lose the removed cover or screws, and make sure to put the product back to the original condition after maintenance and inspection works. <p>Use in incomplete condition may cause damage to the product or an injury.</p> <p>* Safety protection Fence : In the case that there is no safety protection fence, the movable range should be indicated.</p>
9	Modification and Dismantle	<ul style="list-style-type: none"> ● Do not modify, disassemble, assemble or use of maintenance parts not specified based at your own discretion.
10	Disposal	<ul style="list-style-type: none"> ● When the product becomes no longer usable or necessary, dispose of it properly as an industrial waste. ● When removing the actuator for disposal, pay attention to drop of components when detaching screws. ● Do not put the product in a fire when disposing of it. The product may burst or generate toxic gases.
11	Other	<ul style="list-style-type: none"> ● Do not come close to the product or the harnesses if you are a person who requires a support of medical devices such as a pacemaker. Doing so may affect the performance of your medical device. ● See Overseas Specifications Compliance Manual to check whether complies if necessary. ● For the handling of actuators and controllers, follow the dedicated instruction manual of each unit to ensure the safety.

Alert Indication

The safety precautions are divided into “Danger”, “Warning”, “Caution” and “Notice” according to the warning level, as follows, and described in the instruction manual for each model.

Level	Degree of Danger and Damage	Symbol
Danger	This indicates an imminently hazardous situation which, if the product is not handled correctly, will result in death or serious injury.	 Danger
Warning	This indicates a potentially hazardous situation which, if the product is not handled correctly, could result in death or serious injury.	 Warning
Caution	This indicates a potentially hazardous situation which, if the product is not handled correctly, may result in minor injury or property damage.	 Caution
Notice	This indicates lower possibility for the injury, but should be kept to use this product properly.	 Notice

Precautions for Handling

1. Make sure to follow the usage condition, environment and specification range of the product.

In case it is not secured, it may cause a drop in performance or malfunction of the product.

2. Use the dedicated teaching tool.

There are some descriptions regarding information of support start versions, caution notes and how to establish connection in [5.2 Ethernet Connection of XSEL PC Software]. Please check it accordingly.

3. Back up controller data in order to be prepared for a breakdown.

The data to be registered in this controller such as the position data, programs and parameters are written in the flash ROM and FRAM. Therefore, you will not usually lose the data even if the power is shut down. However, make sure to save the latest data so a quick recovery action can be taken in case when the controller is broken and needs to be replaced with another one.

How to save

- (1) Save the data to external memory or hard disk with using the PC software

4. Be cautious about the following points when making communication.

- (1) The Ethernet will be enabled when a reset is executed on the controller equipped with an Ethernet interface board, following a parameter setup (Ethernet function-selection parameter and network environment parameters) by transferring the parameters to the controller and writing them to the flash ROM, and an Ethernet cable connection.

* As Ethernet is equipped in standard for XSEL2 controller, XSEL-RA/SA/RAX/SAX/RAXD/SAXD controllers and RSEL system (SEL unit), the contents described above are valid. Check the connection to the network using a "Ping" command (the command for checking the status of communication on the IP level of TCP/IP using a command prompt) or similar command.

- (2) Build the system by ensuring a sufficient period so that the port opening order of the connected device and controller will satisfy “server port open → client port open”.
- (3) When the controller is used as a server, the number of clients that can be connected to one server-port channel simultaneously is 1.
- (4) When the controller is used as a server, if the IP address and port number of the connected device do not match, the network status will become “connected” and then the connection will close.
When the controller is used as a server, the port number on the client side is not already known in a system where the client’s port number is not bound (the own port number on the client side is assigned automatically). Therefore, set the port number of connection destination to “0” (= Ignore port number of connected device).
With this setting, the first connection from the specified IP address will be considered a valid connection. All connections from other ports of the same IP address will be considered invalid and rejected until the first connection is disconnected.
- (5) When the controller is used as a server, no other port may not be opened (socket cannot be generated) in the event of insufficient socket space caused by continuous external connection to the server port.
- (6) When using the controller side as the server, it is recommended to keep the connection with the mating device while in operation. When having “connecting” → “sending and receiving” → “disconnecting repeatedly” on the mating device side, set an interval of three seconds or more between disconnection and reconnection.
- (7) Build the system in such a way that the power will be shut off only after a disconnection process (socket closure) is performed on the connected-device side whenever the power is to be shut off only to the connected device while maintaining power to the controller.
- (8) The system to be connected to the controller should constantly perform a connection check via polling, etc., and return a close response upon receipt of a closing command from the controller. Given the lack of a close response, in some cases the controller may not be able to open the port (generate a socket).

- (9) Select a straight cable or crossed cable Ethernet cable as deemed appropriate for the connection environment.

[Normal]

Connection details	Cable type
Controller ↔ HUB connection	Straight cable
Connection between controllers	Crossed cable
Controller ↔ PC connection	Crossed cable

- (10) If a firewall (including the firewall function of virus protection software) is installed in the PC, etc., the port block must be canceled or the firewall function disabled before a connection can be made. (This is because the very purpose of firewall software is to block external connection to the protecting device.)
- (11) When the Ethernet is enabled, the system will detect a “link error” if the connection is not made using the correct Ethernet cable. Set I/O parameter No. 10 “Standard I/O error monitor” to “0: Do not monitor” during debugging, teaching or other operation using an SEL program where the Ethernet cable is not connected.
With this setting, in the online mode errors will not be detected even when the Ethernet cable is abnormal. If the system will be used in the online mode, set the above parameter to “1: Monitor” or “2: Monitor (Do not monitor 24V I/O power error)”.
- (12) The IP address of the controller itself cannot be specified as the controller’s connection destination. (Accordingly, a communication test or other operation involving different channels of the same controller cannot be performed.)
- (13) Due to the associated device restrictions, do not set I/O parameter No. 124 “Network attribute 5” to “2: Client (Specify own port number)”.
- (14) When a parameter has been changed, always transfer the setting to the controller, write it to the flash ROM and then reset the software.

(15) If you are contacting IAI to inquire about the encountered problem, please have the following information ready so that we can better assist in a quick recovery and prevent any recurrence of the problem. That information is an essential part of the troubleshooting process.

1)Error list file

2)Parameter file

3)Lighting conditions of the monitor LEDs on the front panel of the Ethernet interface board

* Refer to [Chapter 2 Ethernet Interface Specifications], for details on the monitor LEDs.

4)SEL program file

5)Symbol file

6)Position data file

(16) This manual does not explain how to set up or how to use when using an EtherNet/IP module as a remote I/O.

Refer to [EtherNet/IP Instruction Manual Programming Type Controller Edition (Control Number: ME0308)] provided separately when setting up a remote I/O connection of EtherNet/IP.

(17) The descriptions provided in this manual are based on the standard parameter settings. The content of this manual is subject to change without notice for the purpose of product improvement.

The product names and company names mentioned in this manual are trademarks or registered trademarks of their respective companies.

Ethernet

Chapter **1**

Overview

1.1	Ethernet Communication of Program Controller	1-1
1.2	Characteristics	1-2
1.2.1	Communication / Control of Ethernet	1-2
1.2.2	Transmission by SEL Program (4 channels)	1-3
1.3	Functional Systems of Ethernet	1-4
1.4	Applicable Model List for Ethernet Communication Features	1-5

1.1 Ethernet Communication of Program Controller

Ethernet option^{*2} allows the program controller^{*1} to perform control in an open network environment using the Ethernet infrastructure, the de-facto standard and most common form of communication media for linking PCs and host computers.

*1 It is a generic name of XSEL2, XSEL, RSEL, TTA, MSEL, ASEL/PSEL/SSEL controllers.

*2 It shows an option that equips an Ethernet module or an EtherNet/IP module.

* XSEL2 controller, XSEL-RA/SA/RAX/SAX/RAXD/SAXD controllers and RSEL system (SEL unit) are equipped with Ethernet in standard. (hereinafter described as the “standard Ethernet port”) The standard Ethernet port is available for use only for the message communication.

1.2 Characteristics

1.2.1 Communication / Control of Ethernet

There are two types of communication and control in communication using Ethernet.

* There are some features not applicable depending on controllers.

[1] Message communication

The communication capabilities supported by the RS232C communication function of the program controller can be implemented via Ethernet.

- IAI protocol B/TCP (applicable for TCP/IP of Serial Communication IAI Protocol B)

By this, connection with the XSEL PC teaching software using the Ethernet communication can be available.

[2] Remote I/O control (Modbus/TCP, EtherNet/IP)

The program controller supports remote I/O control via Modbus/TCP.

Modbus/TCP is an Ethernet application of the Modbus protocol used in serial communication.

The input and output are 256 points each at the maximum. Also, the applicable models are as follows.

- XSEL-J/K/JX/KT/KET/KX
- XSEL-P/Q/PX/QX

The controllers applicable for both the message communication and the remote I/O communication in the EtherNet/IP option are as follows:

- XSEL-R/S/RX/SX/RXD/SXD
- XSEL-P/Q type (main application version 1.05 or later)
- XSEL-PX/QX type (main application version 0.51 or later)
- ASEL, PSEL, SSEL, MSEL, TTA

EtherNet/IP available for setting to the program controller options is only for a feature as an adapter (equivalent to slave). It is not applicable for Implicit Message.

Also, refer to [EtherNet/IP Instruction Manual Program Controller Edition (ME0308)] for the remote I/O features and the setup at the startup of EtherNet/IP and related parameters.

1.2.2 Transmission by SEL Program (4 channels)

Four channels of ASCII-based, delimiter-controlled communication are supported, using a set of transmission commands in a system roughly equivalent to that used in the XSEL controller, TTA, MSEL controller and ASEL/PSEL/SSEL controllers serial communication.

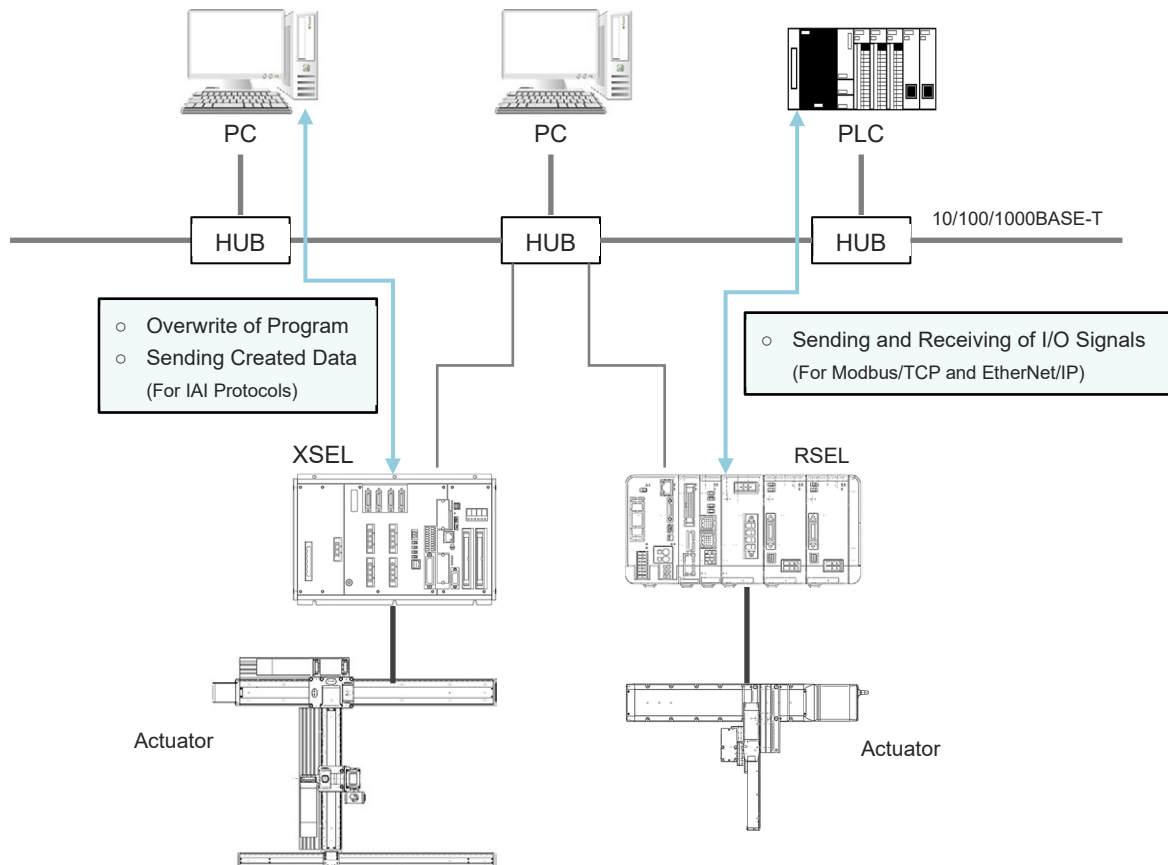

1.3 Functional Systems of Ethernet

A hierarchy of the functions provided by the Ethernet is shown below.

Functions are selected by parameters. Additionally, the network environment parameters must be set.

- * XSEL2 controller, XSEL-RA/SA/RAX/SAX/RAXD/SAXD controllers and RSEL system (SEL unit) are equipped with Ethernet in standard. As the Ethernet in standard feature, it is applicable only for the message communication.
- * Select EtherNet/IP option for XSEL, TTA, MSEL controllers and ASEL/PSEL/SSEL controllers.

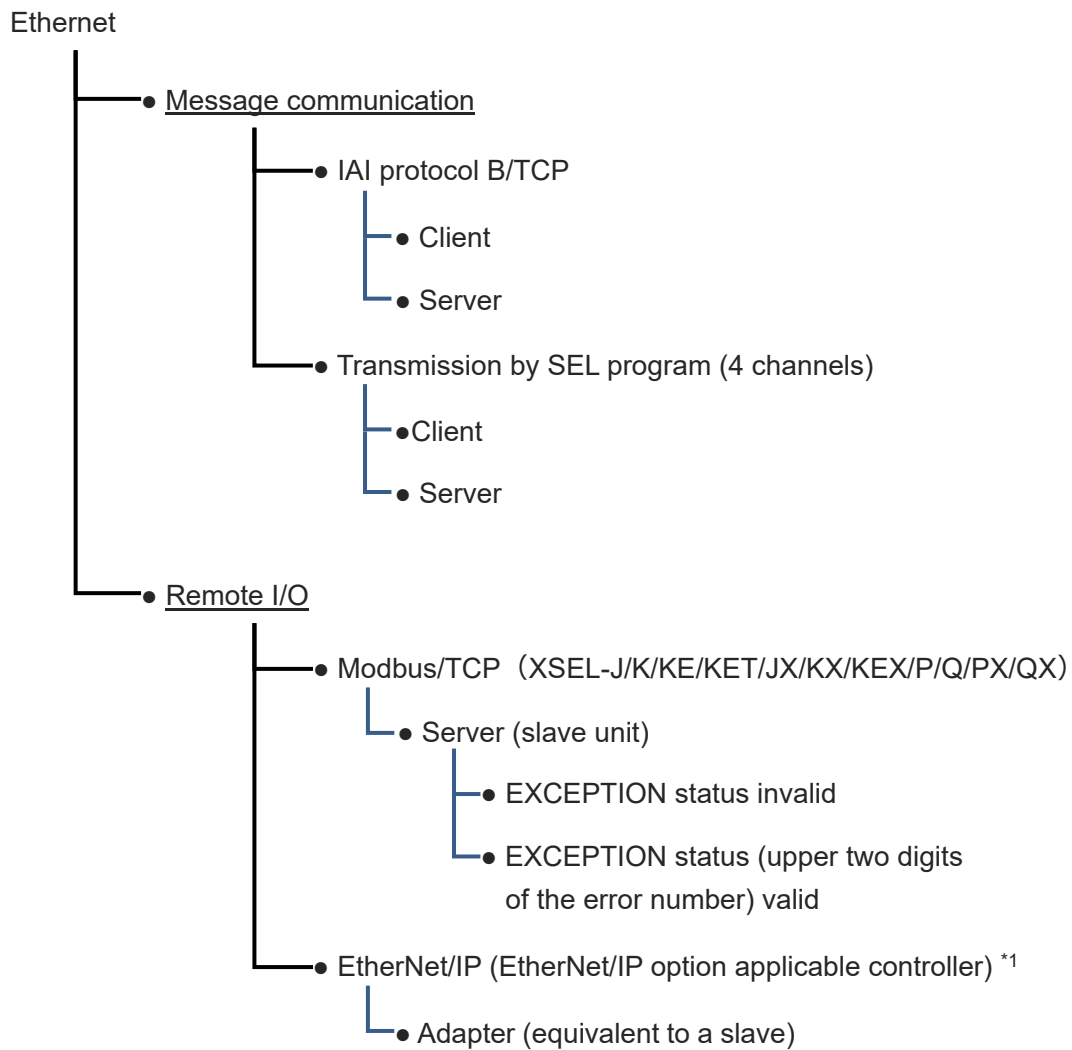

*1 Refer to [EtherNet/IP Instruction Manual Program Controller Edition (ME0308)] for details.

1.4 Applicable Model List for Ethernet Communication Features

	IAI Protocol Format B/TCP	Sending and Receiving by SEL Program in Ethernet Communication		Remote I/O		
		Non-Procedure Communication	Vision System I/F Communication	Modbus/TCP	EtherNet/IP (Note 1)	
Applicable Models	XSEL2	○	○	○	×	△ (Note 1)
	RSEL	○	○	○	×	△ (Note 1)
	XSEL-RA/SA	○	○	○	×	△ (Note 1)
	XSEL-RAX/SAX/RAXD/SAXD	○	○	○	×	△ (Note 1)
	XSEL-R/S	△ (Note 1)	△ (Note 1)	△ (Note 1)	×	△ (Note 1)
	XSEL-RX/SX/RXD/SXD	△ (Note 1)	△ (Note 1)	×	×	△ (Note 1)
	TTA	△ (Note 1)	△ (Note 1)	△ (Note 1)	×	△ (Note 1)
	MSEL-PC/PG/PCF/PGF	△ (Note 1)	△ (Note 1)	△ (Note 1)	×	△ (Note 1)
	MSEL-PCX□/PGX□	△ (Note 1)	△ (Note 1)	×	×	△ (Note 1)
	ASEL/PSEL/SSEL	△ (Note 1)	△ (Note 1)	×	×	△ (Note 1)
	XSEL-P/Q	△ (Note 3)	△ (Note 3)	△ (Note 3)	△ (Note 3)	△ (Note 1)
	XSEL-PX/QX	△ (Note 3)	△ (Note 3)	×	△ (Note 3)	△ (Note 1)
	XSEL-J/K/KE	△ (Note 2)	△ (Note 2)	×	△ (Note 2)	×
	XSEL-JX/KX	△ (Note 2)	△ (Note 2)	×	△ (Note 2)	×

○: Applicable in Standard, △: Applicable in Option, ×: Not Applicable

Note 1 In order to be applicable to this feature, it is necessary to set up EtherNet/IP Option (model code: EP).

Note 2 In order to be applicable to this feature, it is necessary to set up Ethernet Option (model code: ET).

Note 3 In order to be applicable to this feature, it is necessary to set up either Ethernet Option (model code: ET) or EtherNet/IP Option (model code: EP).

*1 Refer to [EtherNet/IP Instruction Manual Program Controller Edition (Control Number: ME0308)] provided separately for EtherNet/IP.



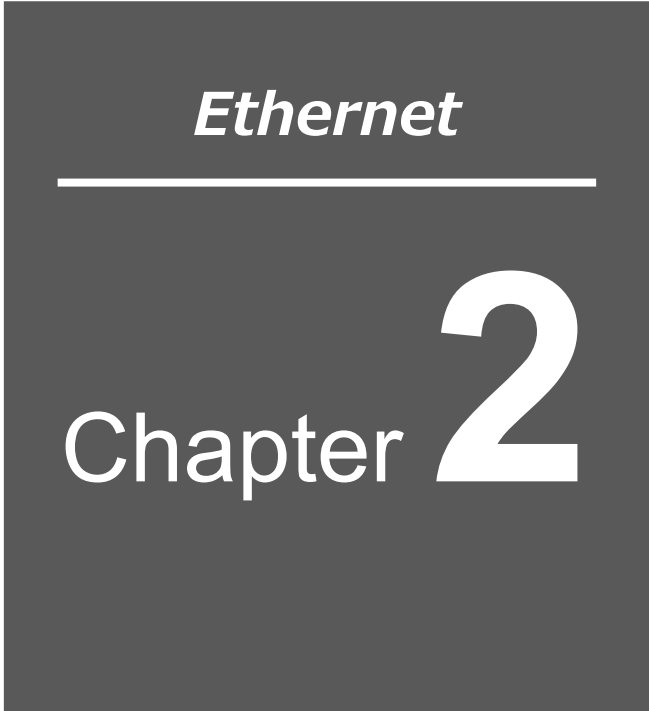

Ethernet Interface Specifications

- 2.1 Standard Ethernet Port for XSEL2 2-1
 - 2.1.1 Name of Each Part 2-1
 - 2.1.2 Network Specification 2-1
 - 2.1.3 Monitor LED Indications 2-2
- 2.2 Standard Ethernet Port for XSEL-RA/SA/RAX/SAX/RAXD/SAXD 2-3
 - 2.2.1 Name of Each Part 2-3
 - 2.2.2 Network Specification 2-3
 - 2.2.3 Monitor LED Indications 2-4
- 2.3 Standard Ethernet Port for RSEL (SEL unit) 2-5
 - 2.3.1 Name of Each Part 2-5
 - 2.3.2 Network Specification 2-5
 - 2.3.3 Monitor LED Indications 2-6

2.4	XSEL-R/S/RX/SX/RXD/SXD	2-7
2.4.1	Model Codes and Name of Each Part	2-7
2.4.2	Network Specification	2-8
2.4.3	Monitor LED Indications	2-9
2.5	TTA Ethernet.....	2-10
2.5.1	Model Codes and Name of Each Part	2-10
2.5.2	Network Specification	2-11
2.5.3	Monitor LED Indications	2-12
2.6	MSEL Ethernet	2-13
2.6.1	Name of Each Part	2-13
2.6.2	Network Specification	2-14
2.6.3	Monitor LED Indications	2-15
2.7	ASEL/PSEL/SSEL Ethernet	2-16
2.7.1	Name of Each Part	2-16
2.7.2	Network Specification	2-17
2.7.3	Monitor LED Indications	2-18
2.8	XSEL-J/K/JX/KX/P/Q/PX/QX Interface Board (Option) ..	2-19
2.8.1	Name of Each Part	2-19
2.8.2	Network Specification	2-20
2.8.3	Monitor LED Indications	2-21

2.1 Standard Ethernet Port for XSEL2

When it is necessary to use the Ethernet features in XSEL2-TS/TL/TXS/TXL, use the standard Ethernet port equipped on the main unit.

2.1.1 Name of Each Part

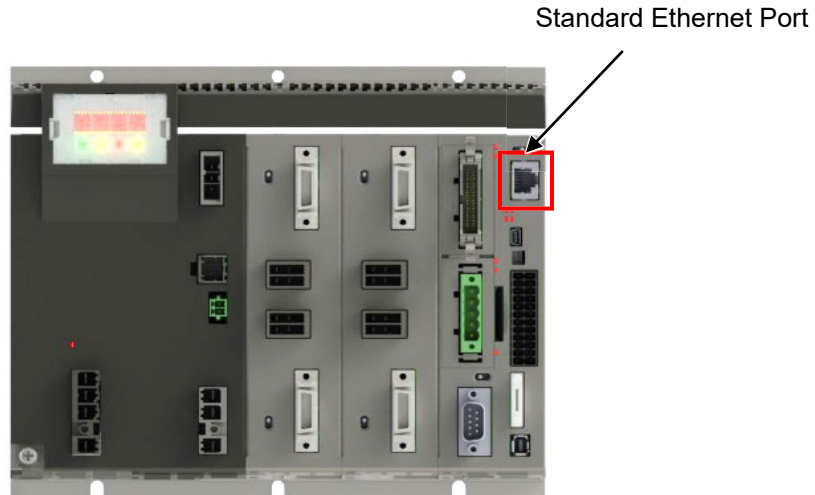

2.1.2 Network Specification

Item	Specification
Network specification	10/100/1000BASE-T (Auto-negotiation)
Communication standard	IEEE802.3
Communication speed	10/100/1000 Mbps (Auto-negotiation)
Protocol	TCP/IP Message Communication 1. IAI protocol B/TCP 2. Transmission by SEL program (4 channels)
Connector	RJ-45
Cable	Ethernet (LAN) cable (Recommended cable : STP cable (manufactured by 3M) Category 5e or above)

* Refer to [3.2 Pin Assignment in Ethernet Connector] for the pin assignment in the connector.

2.1.3 Monitor LED Indications

Two LED lamps located near the connector tell you the operation status of the board and connection status to Ethernet.

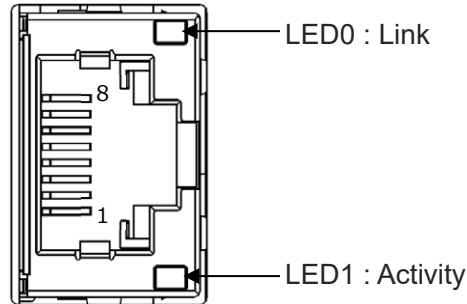

LED	Color	Status	Explanation (factor)
Link	Green	Lit	Linked
		Unlit	Not Linked, Concern of Cable Breakage
Activity	Orange	Blinking	With Traffic
		Unlit	Without Traffic

2.2 Standard Ethernet Port for XSEL-RA/SA/RAX/SAX/RAXD/SAXD

When it is necessary to use the Ethernet features in XSEL-RA/SA/RAX/SAX/RAXD/SAXD, use the standard Ethernet port equipped on the main unit.

2.2.1 Name of Each Part

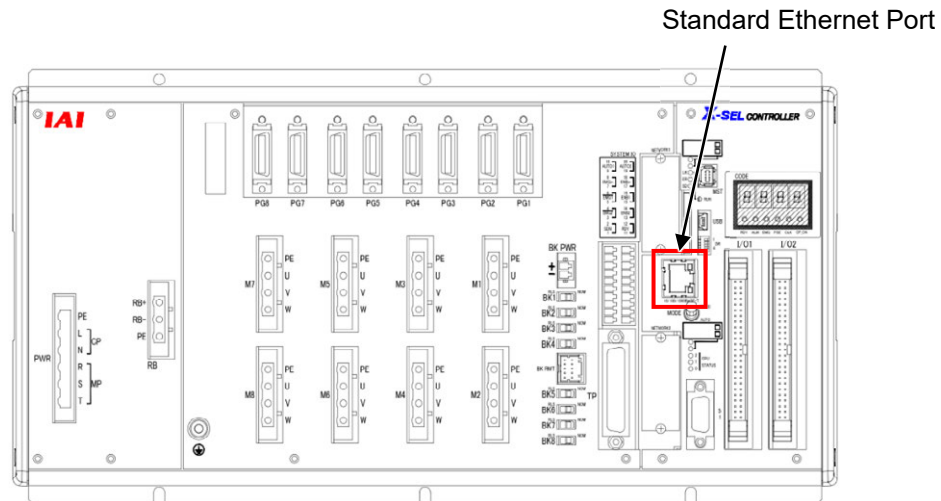

2.2.2 Network Specification

Item	Specification
Network specification	10/100/1000BASE-T (Auto-negotiation)
Communication standard	IEEE802.3
Communication speed	10/100/1000 Mbps (Auto-negotiation)
Protocol	TCP/IP Message Communication 1. IAI protocol B/TCP 2. Transmission by SEL program (4 channels)
Connector	RJ-45
Cable	Category 5 or above (Category 5e or above is recommended.)

* Refer to [3.2 Pin Assignment in Ethernet Connector] for the pin assignment in the connector.

2.2.3 Monitor LED Indications

Two LED lamps located near the connector tell you the operation status of the board and connection status to Ethernet.

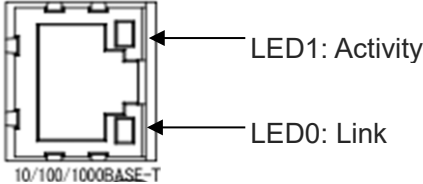

LED	Color	Status	Explanation (factor)
Activity	Orange	Blinking	With Traffic
		Unlit	Without Traffic
Link	Green	Lit	Linked
		Unlit	Not Linked, Concern of Cable Breakage

2.3 Standard Ethernet Port for RSEL (SEL unit)

When it is necessary to use the Ethernet features in RSEL, use the standard Ethernet port equipped on the main unit.

2.3.1 Name of Each Part

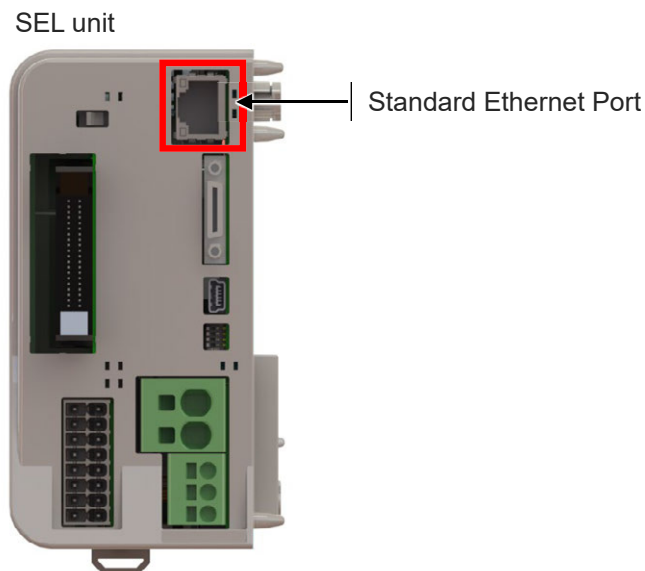

2.3.2 Network Specification

Item	Specification
Network specification	10/100BASE-T
Communication standard	IEEE802.3
Communication speed	10/100 Mbps (Auto-negotiation)
Protocol	TCP/IP Message Communication 1. IAI protocol B/TCP 2. Transmission by SEL program (4 channels)
Connector	RJ-45
Cable	Category 5 or above (Category 5e or above is recommended.)

* Refer to [3.2 Pin Assignment in Ethernet Connector] for the pin assignment in the connector.

2.3.3 Monitor LED Indications

Two LED lamps located near the connector tell you connection status to Ethernet.

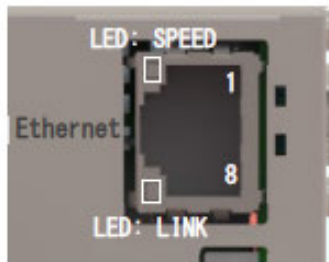

LED	Color	Display Status	Description
SPEED	Orange	Lit	100Mbps Connect
LINK	Green	Unlit	Not Linked
		Lit	Linkage Status Under Detection

2.4 XSEL-R/S/RX/SX/RXD/SXD

2.4.1 Model Codes and Name of Each Part

In order to use the Ethernet features in XSEL-R/S/RX/SX/RXD/SXD, it is necessary to have EtherNet/IP option.

The models are as shown below.

- XSEL-R-□-EP-□
- XSEL-S-□-EP-□
- XSEL-RX-□-EP-□
- XSEL-SX-□-EP-□
- XSEL-RXD-□-EP-□
- XSEL-SXD-□-EP-□

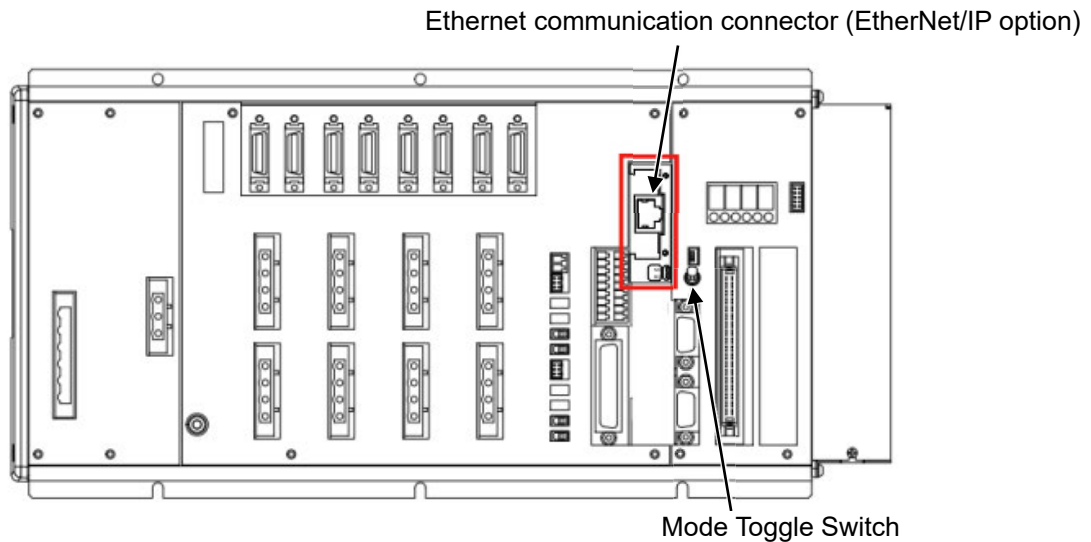

- * Refer to [EtherNet/IP Instruction Manual Program Controller Edition (ME0308)] for how to start up EtherNet/IP and its related parameters.

2.4.2 Network Specification

Item	Specification
Network specification	10/100/1000BASE-T (Auto-negotiation)
Communication standard	IEEE802.3
Communication speed	10/100/1000 Mbps (Auto-negotiation)
Protocol	TCP/IP Message Communication
	<ol style="list-style-type: none"> 1. IAI protocol B/TCP 2. Transmission by SEL program (4 channels)
Connector	RJ-45
Cable	Category 5 or above (Category 5e or above is recommended.)

* Refer to [3.2 Pin Assignment in Ethernet Connector] for the pin assignment in the connector.

2.4.3 Monitor LED Indications

Two LED (Monitor LED) lamps located near the connector tell you the operation status of the board and connection status to Ethernet.

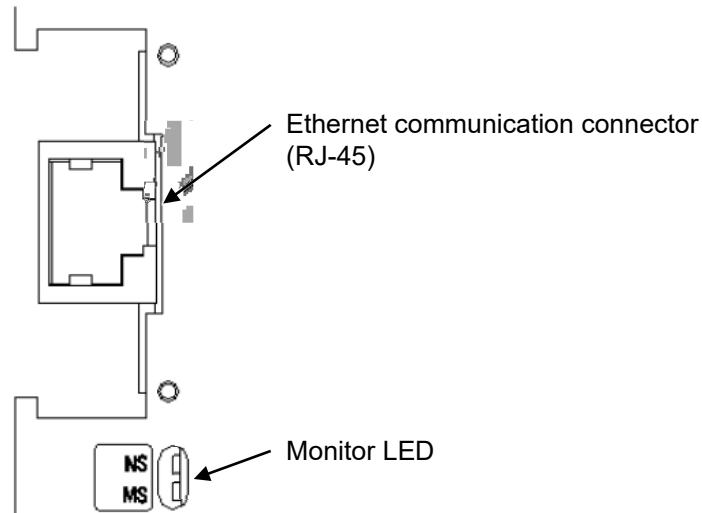

LED	Color	Display Status	Description
NS	Green	Lit	Online, in normal communication in EtherNet/IP
		Blinking	Online, no connectivity to EtherNet/IP
	Orange	Lit	IP address duplicated Critical link error
		Blinking	EtherNet/IP Connection timeout
	–	Unlit	No power supply / IP address sitting unestablished
MS	Green	Lit	In normal operation
		Blinking	EtherNet/IP configuration setting unestablished or incomplete
	Orange	Lit	Error not possible to recover
		Blinking	Error possible to recover
	–	Unlit	No power supply

Note When only TCP/IP message communication is used, both NS and MS flash in green.

2.5.2 Network Specification

Item	Specification
Network specification	10/100BASE-TX (Auto-negotiation)
Communication standard	IEEE802.3
Communication speed	10/100 Mbps (Auto-negotiation)
Protocol	TCP/IP Message Communication
	<ol style="list-style-type: none"> 1. IAI protocol B/TCP 2. Transmission by SEL program (4 channels)
Connector	RJ-45
Cable	Category 5 or above (Category 5e or above is recommended.)

* Refer to [3.2 Pin Assignment in Ethernet Connector] for the pin assignment in the connector.

2.5.3 Monitor LED Indications

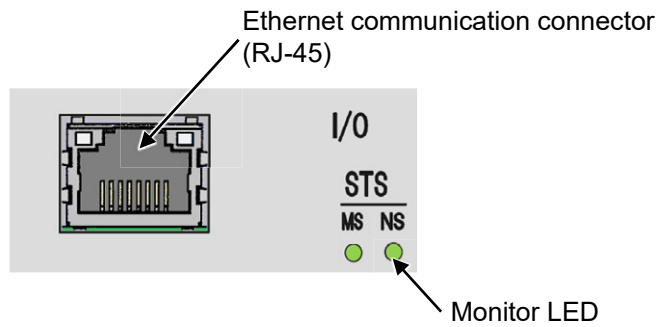

LED	Color	Display Status	Description
NS	Green	Lit	Online, in normal communication in EtherNet/IP
		Blinking	Online, no connectivity to EtherNet/IP
	Orange	Lit	IP address duplicated Critical link error
		Blinking	EtherNet/IP Connection timeout
	–	Unlit	No power supply / IP address sitting unestablished
MS	Green	Lit	In normal operation
		Blinking	EtherNet/IP configuration setting unestablished or incomplete
	Orange	Lit	Error not possible to recover
		Blinking	Error possible to recover
	–	Unlit	No power supply

Note When only TCP/IP message communication is used, both NS and MS flash in green.

2.6 MSEL Ethernet

2.6.1 Name of Each Part

In other to use the Ethernet feature in MSEL, it is necessary to have EtherNet/IP option.
The model codes of MSEL are as shown below.

- MSEL-PC/PG/PCF/PGF-□-EP-□
- MSEL-PCX□/PGX□-□-EP-□

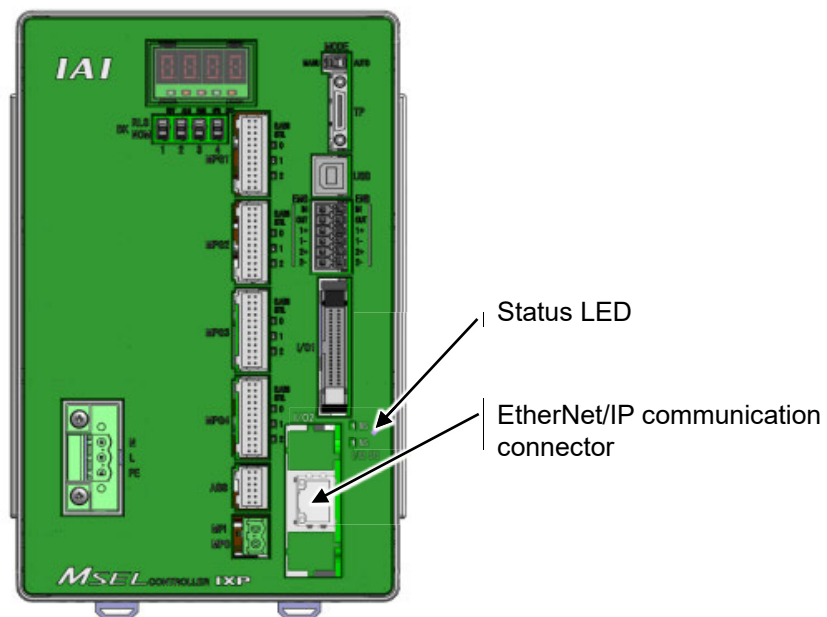

- * Refer to [EtherNet/IP Instruction Manual Program Controller Edition (ME0308)] for how to start up EtherNet/IP and its related parameters.

2.6.2 Network Specification

Item	Specification
Network specification	10/100BASE-TX (Auto-negotiation)
Communication standard	IEEE802.3
Communication speed	10/100 Mbps (Auto-negotiation)
Protocol	TCP/IP Message Communication
	<ol style="list-style-type: none"> 1. IAI protocol B/TCP 2. Transmission by SEL program (4 channels)
Connector	RJ-45
Cable	Category 5 or above (Category 5e or above is recommended.)

* Refer to [3.2 Pin Assignment in Ethernet Connector] for the pin assignment in the connector.

2.6.3 Monitor LED Indications

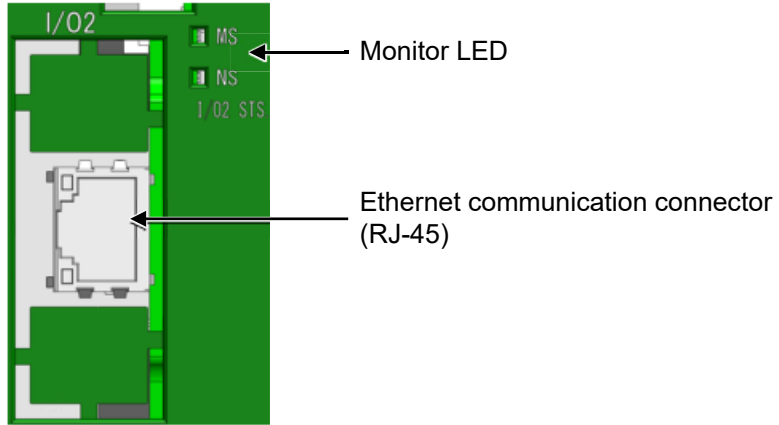

LED	Color	Display Status	Description
NS	Green	Lit	Online, in normal communication in EtherNet/IP
		Blinking	Online, no connectivity to EtherNet/IP
	Orange	Lit	IP address duplicated Critical link error
		Blinking	EtherNet/IP Connection timeout
	–	Unlit	No power supply / IP address sitting unestablished
MS	Green	Lit	In normal operation
		Blinking	EtherNet/IP configuration setting unestablished or incomplete
	Orange	Lit	Error not possible to recover
		Blinking	Error possible to recover
	–	Unlit	No power supply

Note When only TCP/IP message communication is used, both NS and MS flash in green.

2.7 ASEL/PSEL/SSEL Ethernet

2.7.1 Name of Each Part

In other to use the Ethernet features in ASEL/PSEL/SSEL, it is necessary to have EtherNet/IP option. The model codes of ASEL/PSEL/SSEL are as shown below.

- ASEL-CS-□-EP-□
- PSEL-CS-□-EP-□
- SSEL-CS-□-EP-□

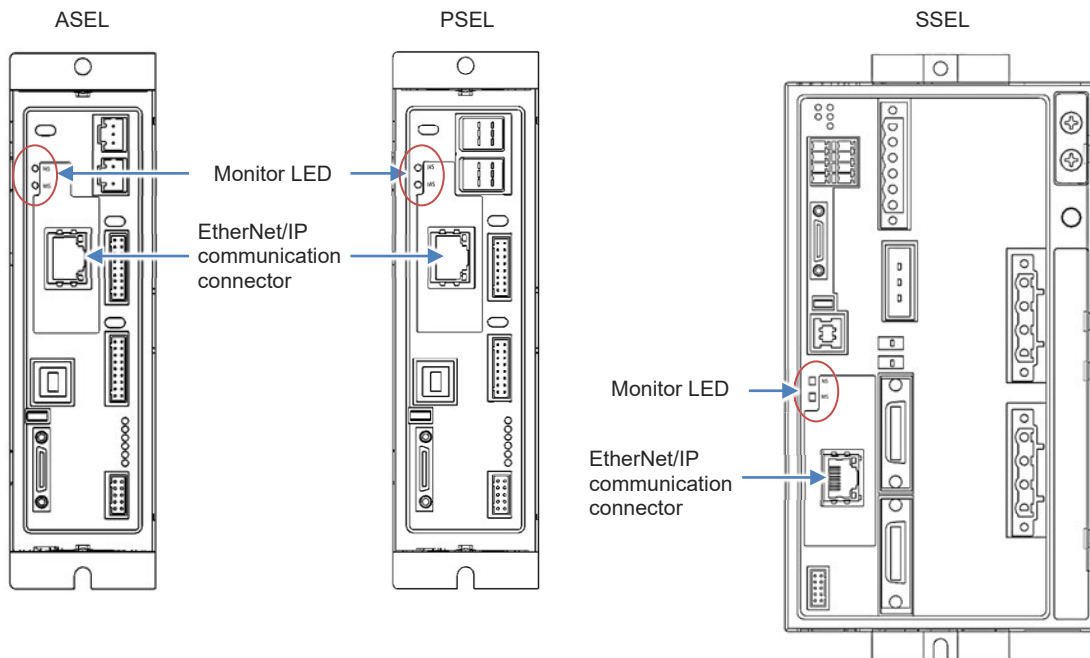

* Refer to [EtherNet/IP Instruction Manual Program Controller Edition (ME0308)] for how to start up EtherNet/IP and its related parameters.

2.7.2 Network Specification

Item	Specification
Network specification	10/100BASE-TX (Auto-negotiation)
Communication standard	IEEE802.3
Communication speed	10/100 Mbps (Auto-negotiation)
Protocol	TCP/IP Message Communication
	<ol style="list-style-type: none"> 1. IAI protocol B/TCP 2. Transmission by SEL program (4 channels)
Connector	RJ-45
Cable	Category 5 or above (Category 5e or above is recommended.)

* Refer to [3.2 Pin Assignment in Ethernet Connector] for the pin assignment in the connector.

2.7.3 Monitor LED Indications

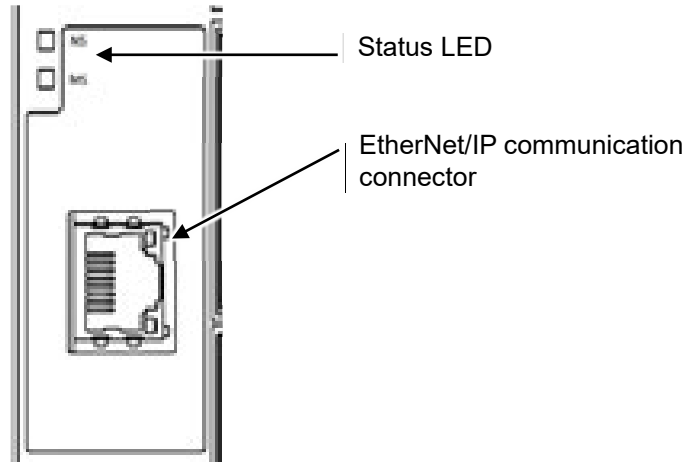

LED	Color	Display Status	Description
NS	Green	Lit	Online, in normal communication in EtherNet/IP
		Blinking	Online, no connectivity to EtherNet/IP
	Orange	Lit	IP address duplicated Critical link error
		Blinking	EtherNet/IP Connection timeout
	-	Unlit	No power supply / IP address sitting unestablished
MS	Green	Lit	In normal operation
		Blinking	EtherNet/IP configuration setting unestablished or incomplete
	Orange	Lit	Error not possible to recover
		Blinking	Error possible to recover
	-	Unlit	No power supply

Note When only TCP/IP message communication is used, both NS and MS flash in green.

2.8 XSEL-J/K/JX/KX/P/Q/PX/QX Interface Board (Option)

2.8.1 Name of Each Part

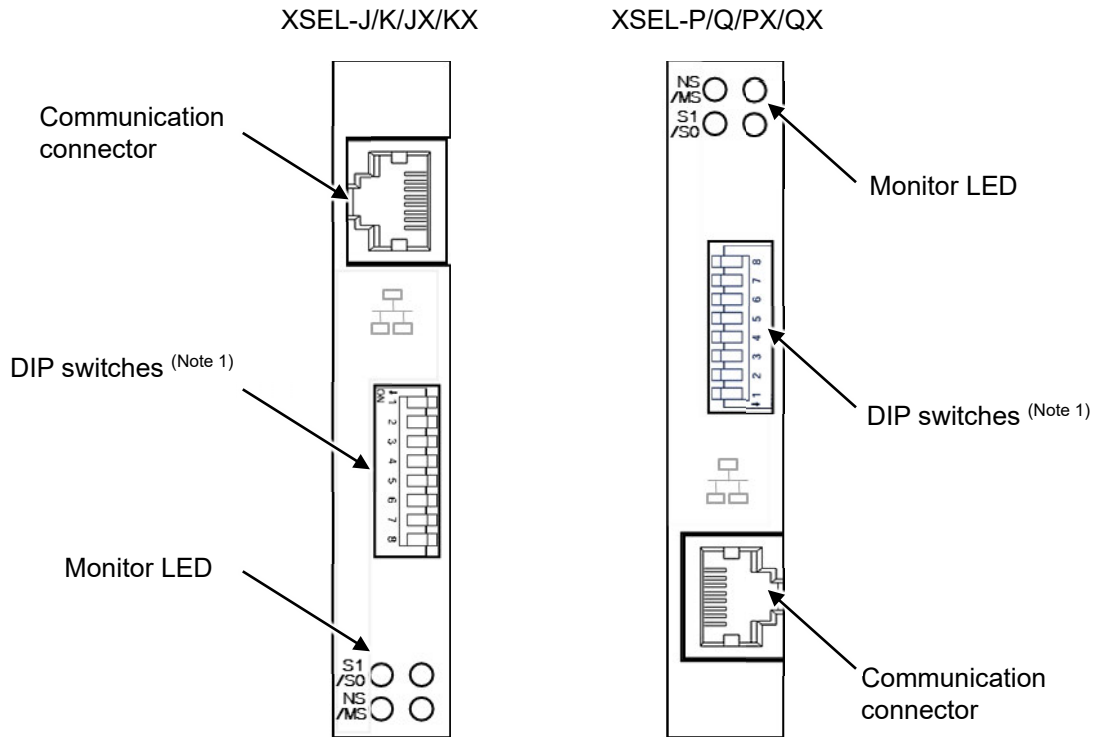

Note 1 The DIP switches are used to set the least significant byte of the IP address. With the XSEL system, however, the IP address is set by a controller parameter without the use of DIP switches.

Set all switches to OFF. (Setting the switches in any other pattern will have no effect.)

* Refer to [EtherNet/IP Instruction Manual Program Controller Edition (Control Number: ME0308)] provided separately when using the remote I/O about the EtherNet/IP options in XSEL-P/Q/PX/QX.

2.8.2 Network Specification

Item	Specification					
Network specification	10BASE-T/100BASE-T (Auto-negotiation)					
Communication standard	IEEE802.3					
Communication speed	10/100Mbps (Auto-negotiation)					
Protocol	Remote I/O				TCP/IP Message Communication	
	Open Modbus/TCP		EtherNet/IP			
	Supported commands	Class 1	Read Coil	Class 1 Class 3 UCMM	Cyclic communication Connection type Non-connection type	1. IAI protocol B/TCP 2. Transmission by SEL program (4 channels)
		Class 1	Read Input Discretes			
		Class 0	Read multiple registers			
		Class 1	Read Input registers			
		Class 1	Write Coils			
		Class 1	Write Single register			
		Class 1	Read Exception status			
		Class 2	Force multiple Coils			
		Class 0	Force multiple registers			
		Class 2	Mask Write register			
Class 2	Read/Write registers					
Connector	RJ-45					
Cable	Category 5 UTP twisted cable ^(Note)					

Note Use a straight cable or crossed cable Ethernet cable according to the connection environment.

Connection method	Cable type
Controller ⇔ HUB	Straight cable
Controller ⇔ Controller	Crossed cable
Controller ⇔ PC	Crossed cable

2.8.3 Monitor LED Indications

The operating condition of the interface board and its connection status to Ethernet can be checked via the four LEDs provided on the front panel of the interface board.

* The LED indications of operating condition and connection condition vary between Modbus/TCP and EtherNet/IP.

● Modbus/TCP or TCP/IP message communication

LED	Color	Status	Definition	Explanation (factor)	
				Open Modbus/TCP (Remote I/O)	TCP/IP Message Communication
S0 (LINK)	–	Unlit	Not linked	The system is not connected to Ethernet.	
	Green	Lit	Linked	The system is connected to Ethernet.	
S1 (TRX)	–	Unlit	No packet	TCP/IP packets are not being transmitted.	
	Green	Lit	Packet detected	TCP/IP packets are being transmitted.	
MS	–	Unlit	No power supply	<ul style="list-style-type: none"> Power is not supplied to the board from the XSEL system. Interface board initialization is not complete. The interface board is being reset. The UTP cable is not connected. 	
	Green	Lit	Default IP operation	IP address is not specified from the controller during operation. (As a rule, this condition should not occur.)	
		Blinking at 1 Hz	Normal operation	The server has started normally via the controller.	
	Red	Lit	Duplicate IPs	Duplicate IP addresses were detected on Ethernet.	
Blinking		Catastrophic failure	<ul style="list-style-type: none"> Module MAC address error (LED blinking at 1 Hz) Network definition read error (LED blinking at 2 Hz) Other module error (LED blinking at 4 Hz) 		
NS	–	Unlit	No Modbus/TCP connection	The Modbus/TCP connection has not been established.	The LED will not be lit in the case of TCP/IP message communication.
	Green	Blinking	Modbus/TCP connection established	A Modbus/TCP connection has been established. (The blinking frequency indicates the number of connections: 1 Hz → 1 connection, 2 Hz → 2 connections.)	

Ethernet

Chapter **3**

Wiring for Ethernet

3.1	Wiring Example	3-1
3.2	Pin Assignment in Ethernet Connector	3-2

3.1 Wiring Example

Shown below is an example of wiring for the Ethernet ports.

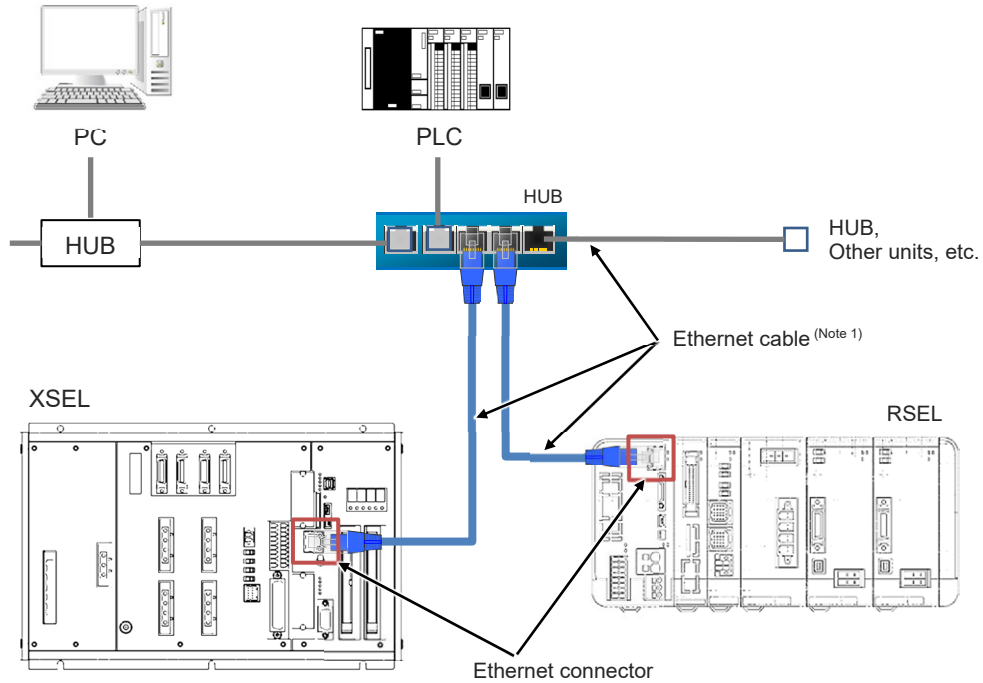

Note 1 Ethernet Cable: Straight cable in Category 5 or higher, 100m or less
(Double shielded cable braid with aluminum tape)

Note Termination is not necessary.

3.2 Pin Assignment in Ethernet Connector

The pin assignment for the Ethernet connector should be as shown below.

[1] Network Specification : 10/100/1000BASE-T

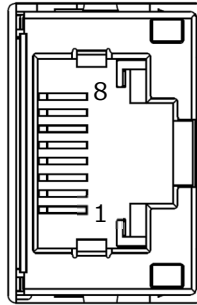

Pin No.	Signal Name		Signal Name
	1000Mbps	10/100Mbps	
1	TRD0+	TXP	Transmission Differential + (Data 0) / Transmit +
2	TRD0-	TNX	Transmission Differential - (Data 0) / Transmit -
3	TRD1+	RXP	Transmission Differential + (Data 1) / Transmit +
4	TRD2+	–	Transmission Differential + (Data 2)
5	TRD2-	–	Transmission Differential - (Data 2)
6	TRD1-	RXN	Transmission Differential - (Data 0) / Transmit -
7	TRD3+	–	Transmission Differential + (Data 3)
8	TRD3-	–	Transmission Differential - (Data 3)

[2] Network Specification : 10BASE-T/100BASE-T

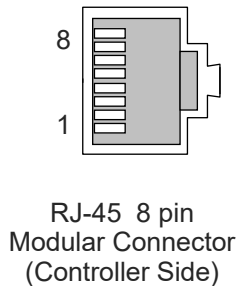

Pin No.	Signal Name	Signal Name
1	Transmit data +	TD+
2	Transmit data –	TD -
3	Receive data +	RD+
4	Not for use	
5	Not for use	
6	Receive data –	RD -
7	Not for use	
8	Not for use	
Connector hood	Protective Ground	FG

Ethernet

Chapter **4**

Ethernet Communication Setting

4.1	XSEL2, XSEL-RA/SA/RAX/SAX/RAXD/SAXD and RSEL System (SEL unit)	4-1
4.1.1	Ethernet Environment Setting of Self Station	4-1
4.1.2	How to Check Communication and Operation	4-3
4.1.3	Related Parameters	4-4
4.2	XSEL-R/S/RX/SX/RXD/SXD, TTA, MSEL, ASEL/PSEL/SSEL Ethernet	4-7
4.2.1	Ethernet Environment Setting of Self Station	4-7
4.2.2	How to Check Communication and Operation	4-11
4.2.3	Related Parameters	4-12
4.3	XSEL-J/K/KT/KET/JX/KX/KXT/P/Q/PX/QX	4-15
4.3.1	Ethernet Environment Setting of Self Station	4-15
4.3.2	How to Check Communication and Operation	4-17
4.3.3	Related Parameters	4-18

4.4	Feature Setting Related to Communication	4-21
4.4.1	Keep-Alive Feature Setting	4-21
4.4.2	Serial Communication Multiple Channels	
	Applicable Feature	4-22
4.5	Check Ping Response from PC	4-24

4.1 XSEL2, XSEL-RA/SA/RAX/SAX/RAXD/SAXD and RSEL System (SEL unit)

4.1.1 Ethernet Environment Setting of Self Station

The XSEL2 controller, XSEL-RA/SA/RAX/SAX/RAXD/SAXD controller and SEL unit provides IP addresses and other network-definition areas in its I/O parameters for control of IAI protocol B/TCP operation.

[1] Setup for TCP/IP Message Communication Use

Set "1: Use TCP/IP Message Communication" in I/O Parameter No. 129 "Network Attribute 10 (Bit 4-7)".

Set "1: Client (self port number automatic assignment)" or "3: Server (Self Port Number Indication)" in I/O Parameter No. 124 "Network Attribute 5 (Bit 0-3 (MANU Mode) or Bit 4-7 (AUTO Mode))".

No.	Parameter name	Setting value	Input range	Remarks
124	Network attribute 5	MANU mode 1 _H or 3 _H AUTO mode 10 _H or 30 _H	0 _H ~ FFFFFFF _H	Ethernet TCP/IP message communication attribute Ethernet client/server type 0: Do not use 1: Client (Assign own port number automatically) 2: System reservation 3: Server (Specify own port number) Note: Number of clients that can be connected to one server-port channel simultaneously = 1 Bits 0 to 3: IAI protocol B/TCP (MANU mode) Bits 4 to 7: IAI protocol B/TCP (AUTO mode) Bits 8 to 11: User-open channel 31 Bits 12 to 15: User-open channel 32 Bits 16 to 19: User-open channel 33 Bits 20 to 23: User-open channel 34 * IAI protocol B/TCP MANU/AUTO The connection will be cut off briefly during switching between the MANU and AUTO modes, if the parameter settings of "own port number", "client/server type", "IP address of connection destination" and "port number of connection destination" do not fully correspond between the two modes.
129	Network attribute 10	10 _H	0 _H ~ FFFFFFF _H	Ethernet operation requirement Bits 0 to 3: Remote I/O * Dependent to controller type Bits 4 to 7: TCP/IP message communication 0: Do not use 1: Use Bits 8 to 31: Reserve (Ethernet operation requirement)

[2] TCP/IP Setting of Self Station

Set "IP Address", "Subnet Mask" and "Default Gateway" of the controller in I/O Parameter No. 172 to 183.

No.	Parameter name	Setting value	Input range	Remarks
172	Ethernet I/F Own IP address (H)	192	1 ~ 255	* Setting of "0" and "127" is prohibited.
173	Ethernet I/F Own IP address (MH)	168	0 ~ 255	
174	Ethernet I/F Own IP address (ML)	0	0 ~ 255	
175	Ethernet I/F Own IP address (L)	1	1 ~ 254	* Setting of "0" and "255" is prohibited.
176	Ethernet I/F Subnet mask (H)	255	0 ~ 255	
177	Ethernet I/F Subnet mask (MH)	255	0 ~ 255	
178	Ethernet I/F Subnet mask (ML)	255	0 ~ 255	
179	Ethernet I/F Subnet mask (L)	0	0 ~ 255	
180	Ethernet I/F Default gateway (H)	0	0 ~ 255	
181	Ethernet I/F Default gateway (MH)	0	0 ~ 255	
182	Ethernet I/F Default gateway (ML)	0	0 ~ 255	
183	Ethernet I/F Default gateway (L)	0	0 ~ 255	

[3] Baud Rate Setting

The Ethernet communication baud rate of XSEL2, XSEL-RA/SA/RAX/SAX/RAXD/SAXD and RSEL system (SEL Unit) should be "Auto Negotiation". There is no parameter setting.

**Caution**

- Set the necessary parameters according to the network environment before connecting to the network. Establishing a connection without setting the parameters may disable normal communication to and from other devices on the network.

4.1.2 How to Check Communication and Operation

[1] Communication Check by Ping Command

To check whether the network setup of the controller is correct, use a “ping” command (the command for checking the status of communication on the IP level of TCP/IP using a command prompt) or similar command.

Refer to [4.5 Check Ping Response from PC] for the detailed process.

[2] Operation Check of IAI Protocol B/TCP

When a controller is used as a server, by setting the connected port number in a Windows enclosed tool “telnet” and the self port number on the controller side, the message communication can be checked.

The connected port during communication should be aligned to the setting in I/O Parameter No. 144 (MANU Mode) or I/O Parameter No. 159 (AUTO Mode) and transfer data following the serial communication specification manual format ^(Note 1) to check its behavior.

Note 1 Refer to [Program Type Controller Serial Communication Specification Manual (Format B) (ME0347)] provided separately for details.

[I/O parameters]

No.	Parameter name	Setting value	Input range	Remarks
144	IAI protocol B/TCP own port number (MANU mode)	64511	1025 ~ 65535	⚠Note: Be sure to set a unique number for each own port number. (The duplication of own port numbers is permitted only in the IAI protocol B/TCP MANU/AUTO modes.)
159	IAI protocol B/TCP own port number (AUTO mode)	64516	1025 ~ 65535	⚠Note: Be sure to set a unique number for each own port number. (The duplication of own port numbers is permitted only in the IAI protocol B/TCP MANU/AUTO modes.)

Refer to [5.3 How to Check IAI Protocol B/TCP Operation by Telnet Client] for detailed process.

4.1.3 Related Parameters

In XSEL2 controller, XSEL-RA/SA/RAX/SAX/RAXD/SAXD controllers and RSEL system (SEL unit), TCP/IP setting (I/P Address • Subnet mask • Default gateway) for Ethernet system field Network (I/O Parameters No. 132 to 143) and for TCP/IP message communication (I/O Parameters No. 172 to 183) should be provided in separate parameters.

Therefore, it is necessary to establish TCP/IP settings for both Ethernet system field Network and TCP/IP message communication when use both of them.

[I/O parameters]

No.	Parameter name	Setting value	Input range	Remarks
124	Network attribute 5	MANU mode 1 _H or 3 _H AUTO mode 10 _H or 30 _H	0 _H ~ FFFFFFF _H	Ethernet TCP/IP message communication attribute Ethernet client/server type 0: Do not use 1: Client (Assign own port number automatically) 2: System reservation 3: Server (Specify own port number) Note: Number of clients that can be connected to one server-port channel simultaneously = 1 Bits 0 to 3: IAI protocol B/TCP (MANU mode) Bits 4 to 7: IAI protocol B/TCP (AUTO mode) Bits 8 to 11: User-open channel 31 Bits 12 to 15: User-open channel 32 Bits 16 to 19: User-open channel 33 Bits 20 to 23: User-open channel 34 * IAI protocol B/TCP MANU/AUTO The connection will be cut off briefly during switching between the MANU and AUTO modes, if the parameter settings of "own port number", "client/server type", "IP address of connection destination" and "port number of connection destination" do not fully correspond between the two modes.
129	Network attribute 10	10 _H	0 _H ~ FFFFFFF _H	Ethernet operation requirement Bits 0 to 3: Remote I/O * Dependent to controller type Bits 4 to 7: TCP/IP message communication 0: Do not use 1: Use Bits 8 to 31: Reserve (Ethernet operation requirement)
144	IAI protocol B/TCP: Own port number (MANU mode)	64511	1025 ~ 65535	⚠Note: Be sure to set a unique number for each own port number. (The duplication of own port numbers is permitted only in the IAI protocol B/TCP MANU/AUTO modes.)
145	User-open channel 31 (TCP/IP): Own port number	64512	1025 ~ 65535	⚠Note: Be sure to set a unique number for each own port number.
146	User-open channel 32 (TCP/IP): Own port number	64513	1025 ~ 65535	⚠Note: Be sure to set a unique number for each own port number.
147	User-open channel 33 (TCP/IP): Own port number	64514	1025 ~ 65535	⚠Note: Be sure to set a unique number for each own port number.
148	User-open channel 34 (TCP/IP): Own port number	64515	1025 ~ 65535	⚠Note: Be sure to set a unique number for each own port number.
149	IAI protocol B/TCP: IP address of connection destination (MANU mode) (H)	192	0 ~ 255	* Setting of "0" and "127" is prohibited.
150	IAI protocol B/TCP: IP address of connection destination (MANU mode) (MH)	168	0 ~ 255	
151	IAI protocol B/TCP: IP address of connection destination (MANU mode) (ML)	0	0 ~ 255	

4.1 XSEL2, XSEL-RA/SA/RAX/SAX/RAXD/SAXD and RSEL System (SEL unit)

No.	Parameter name	Setting value	Input range	Remarks
152	IAI protocol B/TCP: IP address of connection destination (MANU mode) (L)	100	0 ~ 254	* Setting of "0" and "255" is prohibited.
153	IAI protocol B/TCP: Port number of connection destination (MANU mode)	64611	0 ~ 65535	* Available to set to "0" when using as server 0 = Ignore port number of connection destination (Only the IP address is checked.) * In the client mode "0" cannot be set.
154	IAI protocol B/TCP: IP address of connection destination (AUTO mode) (H)	192	0 ~ 255	* Setting of "0" and "127" is prohibited.
155	IAI protocol B/TCP: IP address of connection destination (AUTO mode) (MH)	168	0 ~ 255	
156	IAI protocol B/TCP: IP address of connection destination (AUTO mode) (ML)	0	0 ~ 255	
157	IAI protocol B/TCP: IP address of connection destination (AUTO mode) (L)	100	0 ~ 254	* Setting of "0" and "255" is prohibited.
158	IAI protocol B/TCP: Port number of connection destination (AUTO mode)	64611	0 ~ 65535	* Available to set to "0" when using as server 0 = Ignore port number of connection destination (Only the IP address is checked.) * In the client mode "0" cannot be set.
159	IAI protocol B/TCP: Own port number (AUTO mode)	64516	1025 ~ 65535	⚠Note: Be sure to set a unique number for each own port number. (The duplication of own port numbers is permitted only in the IAI protocol B/TCP MANU/AUTO modes.)
172	Ethernet I/F Own IP address (H)	192	1 ~ 255	* Setting of "0" and "127" is prohibited.
173	Ethernet I/F Own IP address (MH)	168	0 ~ 255	
174	Ethernet I/F Own IP address (ML)	0	0 ~ 255	
175	Ethernet I/F Own IP address (L)	1	1 ~ 254	* Setting of "0" and "255" is prohibited.
176	Ethernet I/F Subnet mask (H)	255	0 ~ 255	
177	Ethernet I/F Subnet mask (MH)	255	0 ~ 255	
178	Ethernet I/F Subnet mask (ML)	255	0 ~ 255	
179	Ethernet I/F Subnet mask (L)	0	0 ~ 255	
180	Ethernet I/F Default gateway (H)	0	0 ~ 255	
181	Ethernet I/F Default gateway (MH)	0	0 ~ 255	
182	Ethernet I/F Default gateway (ML)	0	0 ~ 255	
183	Ethernet I/F Default gateway (L)	0	0 ~ 255	

- * Check the following notice.
1. In order to establish connection to IAI's PC software, both "1: Client (Assign own port number automatically)" and "3: Server (Specify own port number)" are available.
 2. IAI's PC software will detect "Error code ECF: Socket error (PC)" if the controller-side port is disabled due to a mode change on the controller side (MANU ⇔ AUTO switching), reception of an IAI protocol serial-communication message or other reason while the controller is connected to the PC software. This does not indicate abnormal status.
 3. The connection will be cut off briefly during switching between the MANU and AUTO modes under IAI protocol B/TCP, if the parameter settings of "own port number," "client/server type," "IP address of connection destination" and "port number of connection destination" do not fully correspond between the two modes.
 4. One of the two ports will be used for connection, depending on the MANU/AUTO mode.
 5. The port will be enabled at the following intervals:
 - When the initialization after power ON reset is complete
 - When no IAI protocol serial-communication message has been received for approximately five seconds after the completion of controller initialization
 6. The port will be disabled at the following intervals:
 - Upon reception of an IAI protocol serial-communication message
 - * Serial communication having priority. If the PC software is connected via serial communication, Ethernet connection will be cut off.
 - Upon mode change (MANU ⇔ AUTO switching)
 - Upon software reset
 7. If the controller is used as a client, a connection retry will be initiated within approximately two seconds after the recognition of a connection failure (refused, timed out, failed, etc.).
 8. Refer to [Program Type Controller Serial Communication Specification Manual (Format B) (ME0347)] provided separately for details of the message format.
 9. Detection of cable breakage is not available when using only TCP/IP message communication. ("A6B/D5D: Fieldbus Error (FBRS Link Error)" would not occur.)
 10. It may take time for communication process when using several functions of TCP/IP message communication at once or depending on contents of the user program.

4.2 XSEL-R/S/RX/SX/RXD/SXD, TTA, MSEL, ASEL/PSEL/SSEL Ethernet

4.2.1 Ethernet Environment Setting of Self Station

The XSEL-R/S/RX/SX/RXD/SXD, TTA, MSEL controller and ASEL/PSEL/SSEL controllers provides IP addresses and other network-definition areas in its I/O parameters for control of IAI protocol B/TCP operation.

[1] Setup for TCP/IP Message Communication Use

Set "1: Use TCP/IP Message Communication" in I/O Parameter No. 129 "Network Attribute 10 (Bit 4-7)".

Set "1: Client (self port number automatic assignment)" or "3: Server (Self Port Number Indication)" in I/O Parameter No. 124 "Network Attribute 5 (Bit 0-3 (MANU Mode) or Bit 4-7 (AUTO Mode))" when using IAI Protocol B/TCP Features.

[I/O parameters]

No.	Parameter name	Setting value	Input range	Remarks
124	Network attribute 5	MANU mode 1 _H or 3 _H AUTO mode 10 _H or 30 _H	0 _H ~ FFFFFFF _H	<p>Ethernet TCP/IP message communication attribute Ethernet client/server type</p> <p>0: Do not use 1: Client (Assign own port number automatically) 2: System reservation 3: Server (Specify own port number) Note: Number of clients that can be connected to one server-port channel simultaneously = 1</p> <p>Bits 0 to 3: IAI protocol B/TCP (MANU mode) Bits 4 to 7: IAI protocol B/TCP (AUTO mode) Bits 8 to 11: User-open channel 31 Bits 12 to 15: User-open channel 32 Bits 16 to 19: User-open channel 33 Bits 20 to 23: User-open channel 34</p> <p>* IAI protocol B/TCP MANU/AUTO The connection will be cut off briefly during switching between the MANU and AUTO modes, if the parameter settings of "own port number," "client/server type," "IP address of connection destination" and "port number of connection destination" do not fully correspond between the two modes.</p>
129	Network attribute 10	10 _H	0 _H ~ FFFFFFF _H	<p>Ethernet operation requirement</p> <p>Bits 0 to 3: Remote I/O * Dependent to controller type</p> <p>Bits 4 to 7: TCP/IP message communication 0: Do not use 1: Use</p> <p>Bits 8 to 31: Reserve (Ethernet operation requirement)</p>

[2] TCP/IP Setting of Self Station

Set "IP Address", "Subnet Mask" and "Default Gateway" of the controller in I/O Parameter No. 132 to 143.

No.	Parameter name	Setting value	Input range	Remarks
132	Own IP address (H)	192	1 ~ 255	* Setting of "0" and "127" is prohibited.
133	Own IP address (MH)	168	0 ~ 255	
134	Own IP address (ML)	0	0 ~ 255	
135	Own IP address (L)	1	1 ~ 254	* Setting of "0" and "255" is prohibited. (Available to set in the main application V2.00 and later only for MSEL and TTA)
136	Subnet mask (H)	255	0 ~ 255	
137	Subnet mask (MH)	255	0 ~ 255	
138	Subnet mask (ML)	255	0 ~ 255	
139	Subnet mask (L)	0	0 ~ 255	
140	Default gateway (H)	0	0 ~ 255	
141	Default gateway (MH)	0	0 ~ 255	
142	Default gateway (ML)	0	0 ~ 255	
143	Default gateway (L)	0	0 ~ 255	

[3] Baud Rate Setting

The setting of the baud rate is available. It should be set to "0: Automatic Negotiation" on delivery and it is not necessary to make a change to the parameters in the normal use. Set the values in 1 to 4 in case the connectivity of the automatic negotiation cannot be established.

- For XSEL-R/S/RX/SX/RXD/SXD

[I/O parameters]

No.	Parameter name	Setting value	Input range	Parameter name
227	Network I/F Module 1 Communication Attribute 2	0	0 ~ 9	<ul style="list-style-type: none"> For EtherNet/IP: <ul style="list-style-type: none"> 0: Automatic Negotiation 1: 10Mbps (Half Duplex) 2: 10Mbps (Full Duplex) 3: 100Mbps (Half Duplex) 4: 100Mbps (Full Duplex)

• For TTA

The parameter numbers should differ depending on the slots mounted on the EtherNet/IP board.

Set as follows in each condition:

- When EtherNet/IP mounted on Extension I/O Slot 1 (I/O2): I/O Parameter No. 227
- When EtherNet/IP mounted on Extension I/O Slot 2 (I/O3): I/O Parameter No. 238

[I/O parameters]

No.	Parameter name	Default Setting	Input range	Remarks
227	I/O2 Fieldbus Baud Rate	0	0 ~ 9	<ul style="list-style-type: none"> • For EtherNet/IP: 0: Automatic Negotiation 1: 10Mbps (Half Duplex) 2: 10Mbps (Full Duplex) 3: 100Mbps (Half Duplex) 4: 100Mbps (Full Duplex)
238	I/O3 Fieldbus Baud Rate			

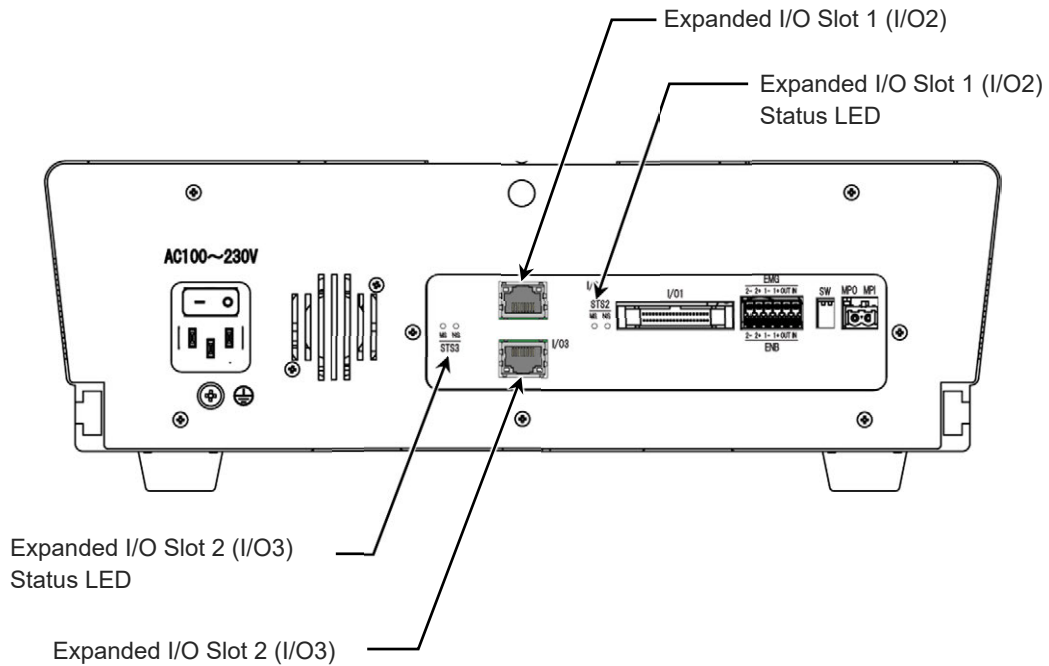

Caution

- The EtherNet/IP connection type option of TTA is available for setting only either to Extension I/O Slot 1 or 2. Also, when an EtherNet/IP module is mounted on Extension I/O Slot 1, the option cannot be set to Extension I/O Slot 2.

• For MSEL

[I/O parameters]

No.	Parameter name	Setting value	Input range	Parameter name
227	I/O2 Fieldbus Baud Rate	0	0 ~ 9	<ul style="list-style-type: none"> • For EtherNet/IP: 0: Automatic Negotiation 1: 10Mbps (Half Duplex) 2: 10Mbps (Full Duplex) 3: 100Mbps (Half Duplex) 4: 100Mbps (Full Duplex)

• For ASEL/PSEL/SSEL

[I/O parameters]

No.	Parameter name	Setting value	Input range	Parameter name
227	Network I/F Module Communication Attribute 2	0	0 ~ 9	Network I/F Module Baud Rate Type * For EtherNet/IP: 0: Automatic Negotiation 1: 10 Mbps (Half Duplex) 2: 20 Mbps (Full Duplex) 3: 100 Mbps (Half Duplex) 4: 100 Mbps (Full Duplex)



Caution

- Set the necessary parameters according to the network environment before connecting to the network. Establishing a connection without setting the parameters may disable normal communication to and from other devices on the network.

4.2.2 How to Check Communication and Operation

[1] Communication Check by Ping Command

To check whether the network setup of the controller is correct, use a “ping” command (the command for checking the status of communication on the IP level of TCP/IP using a command prompt) or similar command.

Refer to [4.5 Check Ping Response from PC] for the detailed process.

[2] Operation Check of IAI Protocol B/TCP

When a controller is used as a server, by setting the connected port number in a Windows enclosed tool “telnet” and the self port number on the controller side, the message communication can be checked.

The connected port during communication should be aligned to the setting in I/O Parameter No. 144 (MANU Mode) or I/O Parameter No. 159 (AUTO Mode) and transfer data following the serial communication specification manual format (Note 1) to check its behavior.

Note 1 Refer to [Program Type Controller Serial Communication Specification Manual (Format B) (ME0347)] provided separately for details.

[I/O parameters]

No.	Parameter name	Setting value	Input range	Remarks
144	IAI protocol B/TCP own port number (MANU mode)	64511	1025 ~ 65535	⚠Note: Be sure to set a unique number for each own port number. (The duplication of own port numbers is permitted only in the IAI protocol B/TCP MANU/AUTO modes.)
159	IAI protocol B/TCP own port number (AUTO mode)	64516	1025 ~ 65535	⚠Note: Be sure to set a unique number for each own port number. (The duplication of own port numbers is permitted only in the IAI protocol B/TCP MANU/AUTO modes.)

Refer to [5.3 How to Check IAI Protocol B/TCP Operation by Telnet Client] for detailed process.

4.2.3 Related Parameters

For XSEL-R/RX/SX/RXD/SXD, TTA, MSEL controllers and ASEL/PSEL/SSEL controllers, the Ethernet system field network and TCP/IP setting for TCP/IP message communication (IP address, subnet mask and default gateway) should be in common.

Therefore, it is not available to use the Ethernet system field network and TCP/IP message communication at the same time.

No.	Parameter name	Setting value	Input range	Remarks
116	(For TTA/MSEL) IAI Protocol Communication Attribute	10 _H	0 _H ~ FFFFFFF _H	Bits 0 to 3: Permission Select of IAI Protocol Multiple Channel Communication 0: Not to Permit * Communication exclusively with priority Teaching port > Ethernet 1: Permit * V2.00 and later of main application part in TTA/MSEL Bits 4 to 11: Select IAI Protocol Execution Command Communication Enabled Channel in AUTO Mode 01 _H : Teaching port 02 _H : Extension SIO (User Release SIO Channel 2) 26 _H : Ethernet * Enabled when Permission Select of IAI Protocol Multiple Channel Communication = "1 (Permit)". * Communication available exclusively with priority Teaching port > Ethernet > Extension SIO in MANU Mode. * Communication available for all the channels for reference command and stop command (execution command). * V2.00 and later of main application part in TTA/MSEL.
124	Network attribute 5	MANU mode 1 _H or 3 _H AUTO mode 10 _H or 30 _H	0 _H ~ FFFFFFF _H	Ethernet TCP/IP message communication attribute Ethernet client/server type 0: Do not use 1: Client (Assign own port number automatically) 2: System reservation 3: Server (Specify own port number) Note: Number of clients that can be connected to one server-port channel simultaneously = 1 Bits 0 to 3: IAI protocol B/TCP (MANU mode) Bits 4 to 7: IAI protocol B/TCP (AUTO mode) Bits 8 to 11: User-open channel 31 Bits 12 to 15: User-open channel 32 Bits 16 to 19: User-open channel 33 Bits 20 to 23: User-open channel 34 * IAI protocol B/TCP MANU/AUTO The connection will be cut off briefly during switching between the MANU and AUTO modes, if the parameter settings of "own port number," "client/server type," "IP address of connection destination" and "port number of connection destination" do not fully correspond between the two modes.
129	Network attribute 10	10 _H	0 _H ~ FFFFFFF _H	Ethernet operation requirement Bits 0 to 3: Remote I/O * Dependent to controller type Bits 4 to 7: TCP/IP message communication 0: Do not use 1: Use Bits 8 to 31: Reserve (Ethernet operation requirement)
132	Own IP address (H)	192	1 ~ 255	* Setting of "0" and "127" is prohibited.

4.2 XSEL-R/S/RX/SX/RXD/SXD, TTA, MSEL, ASEL/PSEL/SSEL Ethernet

No.	Parameter name	Setting value	Input range	Remarks
133	Own IP address (MH)	168	0 ~ 255	
134	Own IP address (ML)	0	0 ~ 255	
135	Own IP address (L)	1	1 ~ 254	* Setting of "0" and "255" is prohibited. (Available to set in the main application V2.00 and later only for MSEL and TTA)
136	Subnet mask (H)	255	0 ~ 255	
137	Subnet mask (MH)	255	0 ~ 255	
138	Subnet mask (ML)	255	0 ~ 255	
139	Subnet mask (L)	0	0 ~ 255	
140	Default gateway (H)	0	0 ~ 255	
141	Default gateway (MH)	0	0 ~ 255	
142	Default gateway (ML)	0	0 ~ 255	
144	IAI protocol B/TCP: Own port number (MANU mode)	64511	1025 ~ 65535	⚠Note: Be sure to set a unique number for each own port number. (The duplication of own port numbers is permitted only in the IAI protocol B/TCP MANU/AUTO modes.)
145	User-open channel31 (TCP/IP): Own port number	64512	1025 ~ 65535	⚠Note: Be sure to set a unique number for each own port number.
146	User-open channel32 (TCP/IP): Own port number	64513	1025 ~ 65535	⚠Note: Be sure to set a unique number for each own port number.
147	User-open channel33 (TCP/IP): Own port number	64514	1025 ~ 65535	⚠Note: Be sure to set a unique number for each own port number.
148	User-open channel34 (TCP/IP): Own port number	64515	1025 ~ 65535	⚠Note: Be sure to set a unique number for each own port number.
149	IAI protocol B/TCP: IP address of connection destination (MANU mode) (H)	192	0 ~ 255	* Setting of "0" and "127" is prohibited.
150	IAI protocol B/TCP: IP address of connection destination (MANU mode) (MH)	168	0 ~ 255	
151	IAI protocol B/TCP: IP address of connection destination (MANU mode) (ML)	0	0 ~ 255	
152	IAI protocol B/TCP: IP address of connection destination (MANU mode) (L)	100	0 ~ 254	* Setting of "0" and "255" is prohibited.
153	IAI protocol B/TCP: Port number of connection destination (MANU mode)	64611	0 ~ 65535	* Available to set to "0" when using as server 0 = Ignore port number of connection destination (Only the IP address is checked.) * In the client mode "0" cannot be set.
154	IAI protocol B/TCP: IP address of connection destination (AUTO mode) (H)	192	0 ~ 255	* Setting of "0" and "127" is prohibited.
155	IAI protocol B/TCP: IP address of connection destination (AUTO mode) (MH)	168	0 ~ 255	

No.	Parameter name	Setting value	Input range	Remarks
156	IAI protocol B/TCP: IP address of connection destination (AUTO mode) (ML)	0	0 ~ 255	
157	IAI protocol B/TCP: IP address of connection destination (AUTO mode) (L)	100	0 ~ 254	* Setting of "0" and "255" is prohibited.
158	IAI protocol B/TCP: Port number of connection destination (AUTO mode)	64611	0 ~ 65535	* Available to set to "0" when using as server 0 = Ignore port number of connection destination (Only the IP address is checked.) * In the client mode "0" cannot be set.
159	IAI protocol B/TCP own port number (AUTO mode)	64516	1025 ~ 65535	⚠Note: Be sure to set a unique number for each own port number. (The duplication of own port numbers is permitted only in the IAI protocol B/TCP MANU/AUTO modes.)

Note Check the following notice.

1. The connection will be cut off briefly during switching between the MANU and AUTO modes under IAI protocol B/TCP, if the parameter settings of "own port number," "client/server type," "IP address of connection destination" and "port number of connection destination" do not fully correspond between the two modes.
2. One of the two ports will be used for connection, depending on the MANU/AUTO mode.
3. The port will be enabled at the following intervals:
 - When the initialization after power ON reset is complete
 - When no IAI protocol serial-communication message has been received for approximately five seconds after the completion of controller initialization
4. The port will be disabled at the following intervals:
 - Upon reception of an IAI protocol serial-communication message
 - * Serial communication having priority. If the PC software is connected via serial communication, Ethernet connection will be cut off.
 - Upon mode change (MANU ⇔ AUTO switching)
 - Upon software reset
 - When the power supply to a controller is cut off
5. If the program controller is used as a client, a connection retry will be initiated within approximately two seconds after the recognition of a connection failure (refused, timed out, failed, etc.).
6. In V2.00 and later of the main CPU application part in TTA/MSEL, one channel exclusively is available for the IAI protocol communication, however, by setting in I/O Parameter No. 116 "IAI Protocol Communication Attribute (bits 0 to 3)" to "1_H", multiple channels gets available for the IAI protocol communication simultaneously.
7. Refer to [Program Type Controller Serial Communication Specification Manual (Format B) (ME0347)] provided separately for details of the message format.

4.3 XSEL-J/K/KT/KET/JX/KX/KXT/P/Q/PX/QX

4.3.1 Ethernet Environment Setting of Self Station

The XSEL-J/K/KT/KET/JX/KX/KXT/P/Q/PX/QX controller provides IP addresses and other network-definition areas in its I/O parameters for control of IAI protocol B/TCP operation.

[1] Setup for TCP/IP Message Communication Use

Set "1: Use TCP/IP Message Communication" in I/O Parameter No. 129 "Network Attribute 10 (Bit 4-7)".

Set "1: Client (self port number automatic assignment)" or "3: Server (Self Port Number Indication)" in I/O Parameter No. 124 "Network Attribute 5 (Bit 0-3 (MANU Mode) or Bit 4-7 (AUTO Mode))" when using IAI Protocol B/TCP Features.

[I/O parameters]

No.	Parameter name	Setting value	Input range	Remarks
124	Network attribute 5	MANU mode 1 _H or 3 _H AUTO mode 10 _H or 30 _H	0 _H ~ FFFFFFF _H	Ethernet TCP/IP message communication attribute Ethernet client/server type 0: Do not use 1: Client (Assign own port number automatically) 2: System reservation 3: Server (Specify own port number) Note: Number of clients that can be connected to one server-port channel simultaneously = 1 Bits 0 to 3: IAI protocol B/TCP (MANU mode) Bits 4 to 7: IAI protocol B/TCP (AUTO mode) Bits 8 to 11: User-open channel 31 Bits 12 to 15: User-open channel 32 Bits 16 to 19: User-open channel 33 Bits 20 to 23: User-open channel 34 * IAI protocol B/TCP MANU/AUTO The connection will be cut off briefly during switching between the MANU and AUTO modes, if the parameter settings of "own port number," "client/server type," "IP address of connection destination" and "port number of connection destination" do not fully correspond between the two modes.
129	Network attribute 10	10 _H	0 _H ~ FFFFFFF _H	Ethernet operation requirement Bits 0 to 3: Remote I/O * Dependent to controller type Bits 4 to 7: TCP/IP message communication 0: Do not use 1: Use Bits 8 to 31: Reserve (Ethernet operation requirement)

[2] TCP/IP Setting of Self Station

Set "IP Address", "Subnet Mask" and "Default Gateway" of the controller in I/O Parameter No. 132 to 143.

No.	Parameter name	Setting value	Input range	Remarks
132	Own IP address (H)	192	1 ~ 255	* Setting of "0" and "127" is prohibited.
133	Own IP address (MH)	168	0 ~ 255	
134	Own IP address (ML)	0	0 ~ 255	
135	Own IP address (L)	1	1 ~ 254	* Setting of "0" and "255" is prohibited. (Available to set in the main application V2.00 and later only for MSEL and TTA)
136	Subnet mask (H)	255	0 ~ 255	
137	Subnet mask (MH)	255	0 ~ 255	
138	Subnet mask (ML)	255	0 ~ 255	
139	Subnet mask (L)	0	0 ~ 255	
140	Default gateway (H)	0	0 ~ 255	
141	Default gateway (MH)	0	0 ~ 255	
142	Default gateway (ML)	0	0 ~ 255	
143	Default gateway (L)	0	0 ~ 255	

[3] Baud Rate Setting

The Ethernet communication baud rate of XSEL-J/K/KT/KET/JX/KX/KXT/P/Q/PX/QX should be "Auto Negotiation". There is no parameter setting.

**Caution**

- Set the necessary parameters according to the network environment before connecting to the network. Establishing a connection without setting the parameters may disable normal communication to and from other devices on the network.

4.3.2 How to Check Communication and Operation

[1] Communication Check by Ping Command

To check whether the network setup of the controller is correct, use a “ping” command (the command for checking the status of communication on the IP level of TCP/IP using a command prompt) or similar command.

Refer to [4.5 Check Ping Response from PC] for the detailed process.

[2] Operation Check of IAI Protocol B/TCP

When a controller is used as a server, by setting the connected port number in a Windows enclosed tool “telnet” and the self port number on the controller side, the message communication can be checked.

The connected port during communication should be aligned to the setting in I/O Parameter No. 144 (MANU Mode) or I/O Parameter No. 159 (AUTO Mode) and transfer data following the serial communication specification manual format (Note 1) to check its behavior.

Note 1 Refer to [Program Type Controller Serial Communication Specification Manual (Format B) (ME0347)] provided separately for details.

[I/O parameters]

No.	Parameter name	Setting value	Input range	Remarks
144	IAI protocol B/TCP own port number (MANU mode)	64511	1025 ~ 65535	⚠Note: Be sure to set a unique number for each own port number. (The duplication of own port numbers is permitted only in the IAI protocol B/TCP MANU/AUTO modes.)
159	IAI protocol B/TCP own port number (AUTO mode)	64516	1025 ~ 65535	⚠Note: Be sure to set a unique number for each own port number. (The duplication of own port numbers is permitted only in the IAI protocol B/TCP MANU/AUTO modes.)

Refer to [5.3 How to Check IAI Protocol B/TCP Operation by Telnet Client] for detailed process.

4.3.3 Related Parameters

[I/O parameters]

No.	Parameter name	Setting value	Input range	Remarks
124	Network attribute 5	MANU mode 1 _H or 3 _H AUTO mode 10 _H or 30 _H	0 _H ~ FFFFFF _H	Ethernet TCP/IP message communication attribute Ethernet client/server type 0: Do not use 1: Client (Assign own port number automatically) 2: Client (Specify own port number) →This setting is not recommended in view of the associated device restrictions, such as a forced-error detection if the port is opened for approximately 10 minutes in a condition where a close response cannot be confirmed due to a power failure in the connected device, etc. 3: Server (Specify own port number) Note: Number of clients that can be connected to one server-port channel simultaneously = 1 Bits 0 to 3: IAI protocol B/TCP (MANU mode) Bits 4 to 7: IAI protocol B/TCP (AUTO mode) Bits 8 to 11: User-open channel 31 Bits 12 to 15: User-open channel 32 Bits 16 to 19: User-open channel 33 Bits 20 to 23: User-open channel 34 * IAI protocol B/TCP MANU/AUTO The connection will be cut off briefly during switching between the MANU and AUTO modes, if the parameter settings of "own port number", "client/server type", "IP address of connection destination" and "port number of connection destination" do not fully correspond between the two modes.
⋮	⋮	⋮	⋮	⋮
129	Network attribute 10	10 _H	0 _H ~ FFFFFF _H	Ethernet operation requirement Bits 0 to 3: Remote I/O 0: Do not use 1: Use Modbus/TCP (EXCEPTION status invalid) 2: Use Modbus/TCP (EXCEPTION status valid) 3: Use EtherNet/IP Bits 4 to 7: TCP/IP message communication 0: Do not use 1: Use Bits 8 to 31: Not used
130	Own MAC address (H)	0030 _H	Reference value (HEX)	Only the lower two bytes are valid. (This parameter is not settable.)
131	Own MAC address (L)	11 _H	Reference value (HEX)	(This parameter is not settable.)
132	Own IP address (H)	192	1 ~ 255	* Setting of "0" and "127" is prohibited.
133	Own IP address (MH)	168	0 ~ 255	
134	Own IP address (ML)	0	0 ~ 255	
135	Own IP address (L)	1	1 ~ 254	* Setting of "0" and "255" is prohibited.
136	Subnet mask (H)	255	0 ~ 255	
137	Subnet mask (MH)	255	0 ~ 255	
138	Subnet mask (ML)	255	0 ~ 255	
139	Subnet mask (L)	0	0 ~ 255	

No.	Parameter name	Setting value	Input range	Remarks
140	Default gateway (H)	0	0 ~ 255	
141	Default gateway (MH)	0	0 ~ 255	
142	Default gateway (ML)	0	0 ~ 255	
143	Default gateway (L)	0	0 ~ 255	
⋮	⋮	⋮	⋮	⋮
149	IAI protocol B/TCP: IP address of connection destination (MANU mode) (H)	192	1 ~ 255	* Setting of "0" and "127" is prohibited.
150	IAI protocol B/TCP: IP address of connection destination (MANU mode) (MH)	168	0 ~ 255	
151	IAI protocol B/TCP: IP address of connection destination (MANU mode) (ML)	0	0 ~ 255	
152	IAI protocol B/TCP: IP address of connection destination (MANU mode) (L)	100	1 ~ 254	* Setting of "0" and "255" is prohibited.
153	IAI protocol B/TCP: Port number of connection destination (MANU mode)	64611	0 ~ 65535	In parameter No.124, * Available to set to "0" when using as server 0 = Ignore port number of connection destination (Only the IP address is checked.) * Not available to set to "0" when set as client
154	IAI protocol B/TCP: IP address of connection destination (AUTO mode) (H)	192	1 ~ 255	* Setting of "0" and "127" is prohibited.
155	IAI protocol B/TCP: IP address of connection destination (AUTO mode) (MH)	168	0 ~ 255	
156	IAI protocol B/TCP: IP address of connection destination (AUTO mode) (ML)	0	0 ~ 255	
157	IAI protocol B/TCP: IP address of connection destination (AUTO mode) (L)	100	1 ~ 254	* Setting of "0" and "255" is prohibited.
158	IAI protocol B/TCP: Port number of connection destination (AUTO mode)	64611	0 ~ 65535	In parameter No.124, * Available to set to "0" when using as server 0 = Ignore port number of connection destination (Only the IP address is checked.) * Not available to set to "0" when set as client

Note Check the following notice.

1. In order to establish connection to IAI's PC software, both "1: Client (Assign own port number automatically)" and "3: Server (Specify own port number)" are available. However, it is necessary to set to "1: Client (Assign own port number automatically)" when connecting to the PC software version V13.00.00.00 or earlier.
2. IAI's PC software will detect "Error No. ECF: Socket error (PC)" if the controller-side port is disabled due to a mode change on the controller side (MANU \leftrightarrow AUTO switching), reception of an IAI protocol serial-communication message or other reason while the controller is connected to the PC software. This does not indicate abnormal status.
3. The connection will be cut off briefly during switching between the MANU and AUTO modes under IAI protocol B/TCP, if the parameter settings of "own port number," "client/server type," "IP address of connection destination" and "port number of connection destination" do not fully correspond between the two modes.
4. One of the two ports will be used for connection, depending on the MANU/AUTO mode.
5. The port will be enabled at the following intervals:
 - When the initialization after power ON reset is complete
 - When no IAI protocol serial-communication message has been received for approximately five seconds after the completion of controller initialization
6. The port will be disabled at the following intervals:
 - Upon reception of an IAI protocol serial-communication message (serial communication having priority. If the PC software is connected via serial communication, Ethernet connection will be cut off.)
 - Upon mode change (MANU \leftrightarrow AUTO switching)
 - Upon software reset
7. If the controller is used as a client, a connection retry will be initiated within approximately two seconds after the recognition of a connection failure (refused, timed out, failed, etc.).
8. Refer to [Program Type Controller Serial Communication Specification Manual (Format B) (ME0347)] provided separately for details of the message format.

4.4 Feature Setting Related to Communication

4.4.1 Keep-Alive Feature Setting

Using the keep-alive feature, and confirmation of alive can be conducted to see if the host (to be connected) can receive a response by sending TCP Keep Alive Packet when there is no communication held for a certain period of time.

Applicable Models
XSEL2 RSEL XSEL-RA/SA, XSEL-RAX/RAXD/SAX/SAXD, XSEL-R/S, XSEL-RX/SX/RXD/SXD ASEL/PSEL/SSEL, TTA, MSEL

- I/O parameter

No.	Parameter name	Default Setting	Input range	Remarks
123	Network attribute 4	0 _H	0 _H ~ FFFFFFF _H	Bits 0 to 3: Ethernet TCP/IP message communication Selection of whether or not to permit IP address 0.0.0.0 (a specification to ignore the IP address of the connected device) as the connection destination when the controller is used as a server (0: Do not permit, 1: Permit (This setting is not recommended)) Note: Number of clients that can be connected to one server-port channel simultaneously = 1 Bits 4 to 7: Ethernet IAI protocol B/TCP (MANU mode) Select Keep-Alive Feature Bits 8 to 11: Ethernet IAI protocol B/TCP (AUTO mode) Select Keep-Alive Feature Bits 12 to 15: Ethernet user-open channel 31 Select Keep-Alive Feature Bits 16 to 19: Ethernet user-open channel 32 Select Keep-Alive Feature Bits 20 to 23: Ethernet user-open channel 33 Select Keep-Alive Feature Bits 24 to 27: Ethernet user-open channel 34 Select Keep-Alive Feature * Setting of Bit 4-7 to Bit 24-27 should be 0: Do not use, 1: Use KeepAlive * The connection may get cut when a mating device is not applicable for TCP KeepAlive Feature.

The detail of specifications for the keep-alive feature in the program controllers should be as shown below.

Contents	Value
Time before first Keep Alive Packet sent	120min
Frequency of sending Keep Alive Packet	75s
Retry count for sending Keep Alive Packet	8 Times

* The connection may get cut when a host (to be connected) is not applicable for TCP KeepAlive Feature, so do not attempt to use.

4.4.2 Serial Communication Multiple Channels Applicable Feature

Serial communication is effective only to one channel currently. However, it can be applicable to multiple channel communication with this feature.

Use with connection of the PC software, teaching pendant, programmable display and so on at the same time cones available.

Applicable Models
XSEL2 ^{Note 1} RSEL ^{Note 2} TTA, MSEL ^{Note 3}

Note 1 XSEL2 is applicable in the main CPU application “V1.01 and after”.

Note 2 RSEL is applicable in the main CPU application “V1.09 and after”.

Note 3 TTA and MSEL are applicable in the main CPU application “V2.00 and after”.

* This feature is set “disabled” on delivery.

[I/O parameters]

No.	Parameter name	Setting value	Input range	Remarks
116	(For TTA/MSEL) IAI Protocol Communication Attribute	10 _H	0 _H ~ FFFFFFF _H	Bits 0 to 3: Permission Select of IAI Protocol Multiple Channel Communication 0: Not to Permit * Communication exclusively with priority Teaching port > Ethernet 1: Permit Bits 4 to 11: Select IAI Protocol Execution Command Communication Enabled Channel in AUTO Mode 01 _H : Teaching port 02 _H : Extension SIO (User Release SIO Channel 2) 26 _H : Ethernet * Enabled when Permission Select of IAI Protocol Multiple Channel Communication = 1 (Permit) * Communication available exclusively with priority Teaching port > Ethernet > Extension SIO in MANU Mode * Communication available for all the channels for reference command and stop command (execution command)

The inquiry system commands in the IAI protocol should always be enabled in multiple channels, but the execution system commands may get disabled depending on channels. In the channels disabled, the execution system commands should have no response (communication cutoff for teaching pendant and XSEL PC software), thus it is necessary to construct the user system to have one channel for the execution command sending.

The channels that the execution system commands get enabled should differ in MANU Mode and AUTO Mode.

■ **MANU mode**

In case it is required to receive the execution system commands in multiple channels simultaneously.

The priority should be “(Teaching port) > (Ethernet) > (Extension SIO)”.

For instance, if an execution system command is attempted to be received by a teaching port and the extension SIO at the same time, the execution command received by the teaching port should get enabled and respond, and the command received by the extension SIO should get disabled and be no response.

■ **AUTO mode**

Only the channels set in I/O Parameter No. 116 “IAI Protocol Communication Attribute (Bits 4 to 11)” should get enabled and execution system commands in channels not set should get disabled and be no response.

4.5 Check Ping Response from PC

Using Ping commands, the communication should be confirmed between a program controller and a PC.

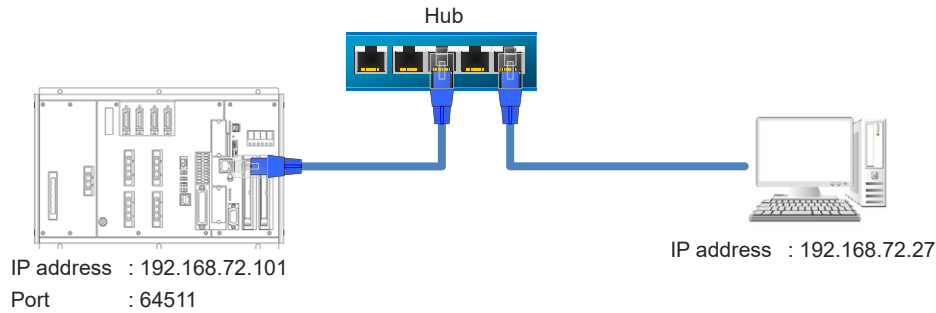

[How to Check]

- * Start up in advance the command line tool such as a command prompt.

- 1) Input "ping_IP address" and press the Enter key.

```
S C:\Users\¥User> ping 192.168.250.10
```

- 2) Input "ping_IP address" and press the Enter key.

```
PS C:\Users\¥User> ping 192.168.250.10
Pinging 192.168.250.100 with 32 bytes of data:
Reply from 192.168.250.100: bytes=32 time<1ms TTL=64
Reply from 192.168.250.100: bytes=32 time<1ms TTL=64
Reply from 192.168.250.100: bytes=32 time<1ms TTL=64
Reply from 192.168.250.100: bytes=32 time<1ms TTL=64

Ping statistics for 192.168.250.100:
    Packets: Sent = 4, Received = 4, Lost = 0 (0% loss),
    Approximate round trip times in milli-seconds:
        Minimum = 0ms, Maximum = 0ms, Average = 0ms
```

In case of communication failure, the following message should be shown.

```
PS C:\Users\User> ping 192.168.250.10
Pinging 192.168.250.10 with 32 bytes of data:
Reply from 192.168.72.27: Destination host unreachable.
Reply from 192.168.72.27: Destination host unreachable.
Reply from 192.168.72.27: Destination host unreachable.
Reply from 192.168.72.27: Destination host unreachable.
Ping statistics for 192.168.250.10:
    Packets: Sent = 4, Received = 4, Lost = 0 (0% loss),
PS C:\Users\User>
```

- * If a security software with the firewall feature effective is installed, there may be a case “Request timed out” is displayed even if the connection with a mating device is established. If a security software is installed, deactivate the firewall feature and conduct a ping command again.
Consult with each software supplier for process regarding the setup.

Ethernet

Chapter 5

IAI Protocol B/TCP

5.1	What is IAI Protocol B/TCP	5-1
5.2	Ethernet Connection of XSEL PC Software	5-2
5.2.1	Software Versions Supporting This Function	5-2
5.2.2	Items to Note	5-3
5.2.3	When Using PC (XSEL PC software) as Sever	5-4
5.2.4	When Using PC (XSEL PC Software) as Client	5-11
5.3	How to Check Operation of IAI Protocol B/TCP by Telnet Client	5-17

5.1 What is IAI Protocol B/TCP

This protocol uses TCP packets embedded with the message format of IAI protocol B for serial communication. The program controller supports the slaves under this protocol, regardless of the connection method (client or server).

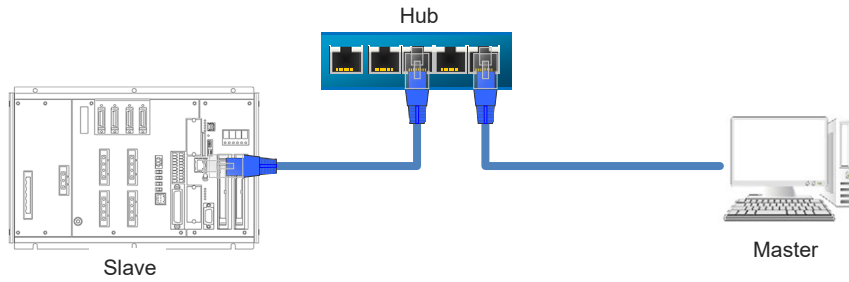

* The connected device always becomes the protocol master.

5.2 Ethernet Connection of XSEL PC Software

5.2.1 Software Versions Supporting This Function

- PC software (Applicable only for server) V2.1.0.0
- PC software (Applicable for both server and client) V13.0.0.0

Supplement Program controllers and Ethernet communication (IAI protocol B/TCP communication) for XSEL PC software are now available for both server and client from the XSEL PC software version V13.0.0.0.

5.2.2 Items to Note

- (1) When connecting via Ethernet, the IP address parameter must be set via serial connection beforehand in accordance with the applicable environment.
- (2) If a firewall (including the firewall function of virus protection software) is installed in the PC, etc., the port block must be canceled or the firewall function disabled before a connection can be made. (This is because the very purpose of firewall software is to block external connection to the protecting device.)
- (3) Ethernet connection is enabled only when the checkbox “The connection to the CTL by Ethernet is supported”, as provided on the “Setting” tab accessed by selecting “Tools” → “Environment Setup” from the menu, is selected.

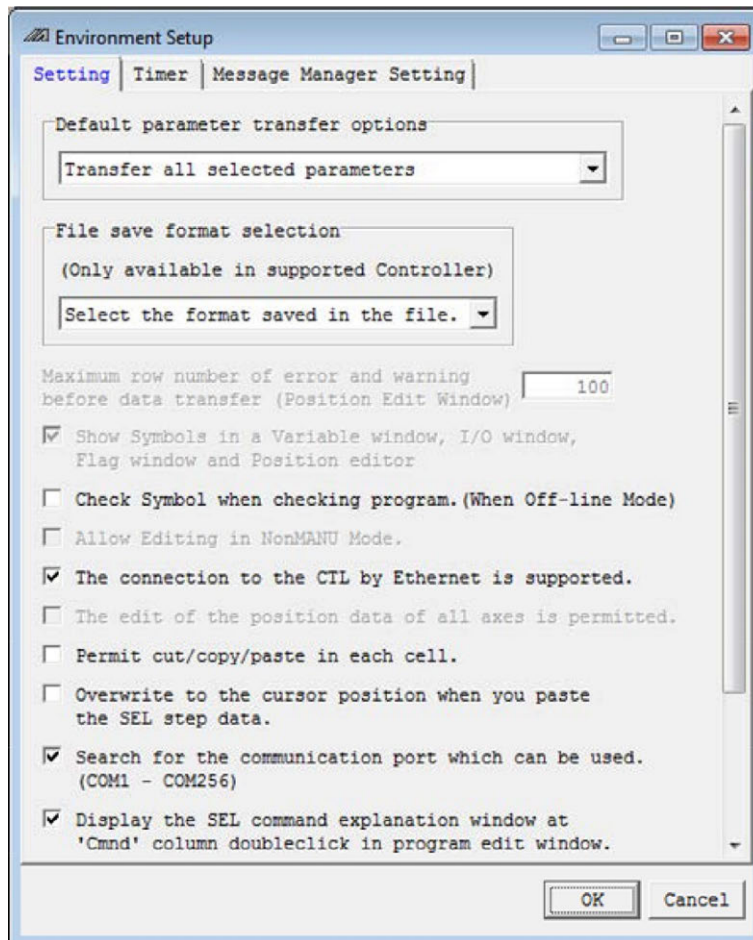

5.2.3 When Using PC (XSEL PC software) as Sever

[1] Parameter setting

Establish the setting of I/O Parameters in advance as shown below:

[I/O parameters]

No.	Name	Setting value
124	Network attribute 5	Set Bits 0 to 3 "IAI protocol B/TCP (MANU mode)" and Bits 4 to 7 "IAI protocol B/TCP (AUTO mode)" to "1: Client (Assign own port number automatically)". (Set Bits 0 to 3 when communication in MANU mode and set Bits 4 to 7 when communication in AUTO mode)
129	Network attribute 10	Set bits 4 to 7 "TCP/IP message communication" to "1: Use"
132-135	Own IP address	IP Address on Controller (Setting to be established for controllers other than XSEL-RA/SA/RAX/SAX/RAXD/SAXD and RSEL system (SEL unit))
136-139	Subnet mask	Subnet Mask for Network Environment of Your Use (Setting to be established for controllers other than XSEL-RA/SA/RAX/SAX/RAXD/SAXD and RSEL system (SEL unit))
140-143	Default gateway	Default Gateway for Network Environment of Your Use (Setting to be established for controllers other than XSEL-RA/SA/RAX/SAX/RAXD/SAXD and RSEL system (SEL unit))
149-152	IAI protocol B/TCP: IP address of connection destination (MANU mode)	IP Address of PC to Communicate with Controller (Setting to be established when communication in MANU mode)
153	IAI protocol B/TCP: Port number of connection destination (MANU mode)	Standby Port Number for XSEL PC Software (Server) (Setting to be established when communication in MANU mode)
154-157	IAI protocol B/TCP: IP address of connection destination (AUTO mode)	IP Address of PC to Communicate with Controller (Setting to be established when communication in AUTO mode)
158	IAI protocol B/TCP: Port number of connection destination (AUTO mode)	Standby Port Number for XSEL PC Software (Server) (Setting to be established when communication in AUTO mode)
172-175	Ethernet I/F own IP address	IP Address on Controller (Setting to be established for XSEL-RA/SA/RAX/SAX/RAXD/SAXD controllers and RSEL system (SEL unit))
176-179	Ethernet I/F subnet mask	Subnet Mask for Network Environment of Your Use (Setting to be established for XSEL-RA/SA/RAX/SAX/RAXD/SAXD controllers and RSEL system (SEL unit))
180-183	Ethernet I/F default gateway	Default Gateway for Network Environment of Your Use (Setting to be established for XSEL-RA/SA/RAX/SAX/RAXD/SAXD controllers and RSEL system (SEL unit))

[How to set up Parameters in Simple Setup]

Here, explains how to establish setup using the parameter simple setup window.

1. From “Parameter” in the main menu window, click **Easy Parameter Setup** .

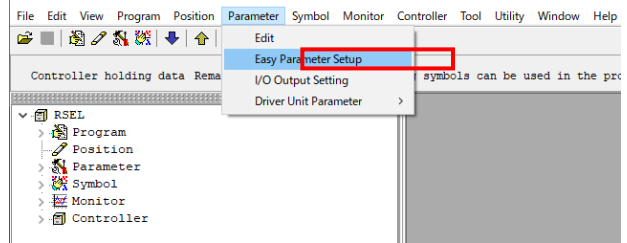

2. As the parameter simple setup window shows up, click **Ethernet** .

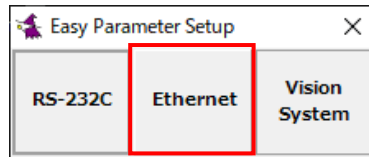

3. Input values to be set in “IP Address (SEL controller)”, “Subnet Mask” and “Default Gateway” from Common in the Ethernet Setup window.

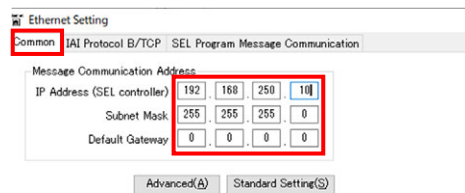

Caution

- Make sure the IP address would not duplicate with another device in the same network when the setup is established.

- Click "IAI Protocol B/TCP" in the Ethernet Setup window, select or input each item. By clicking **Set same as "For Controller MANU Mode" (M)**, the setting in AUTO Mode can be made the same as the one input in MANU Mode. After the setup is complete, click **Transmit to Controller**.

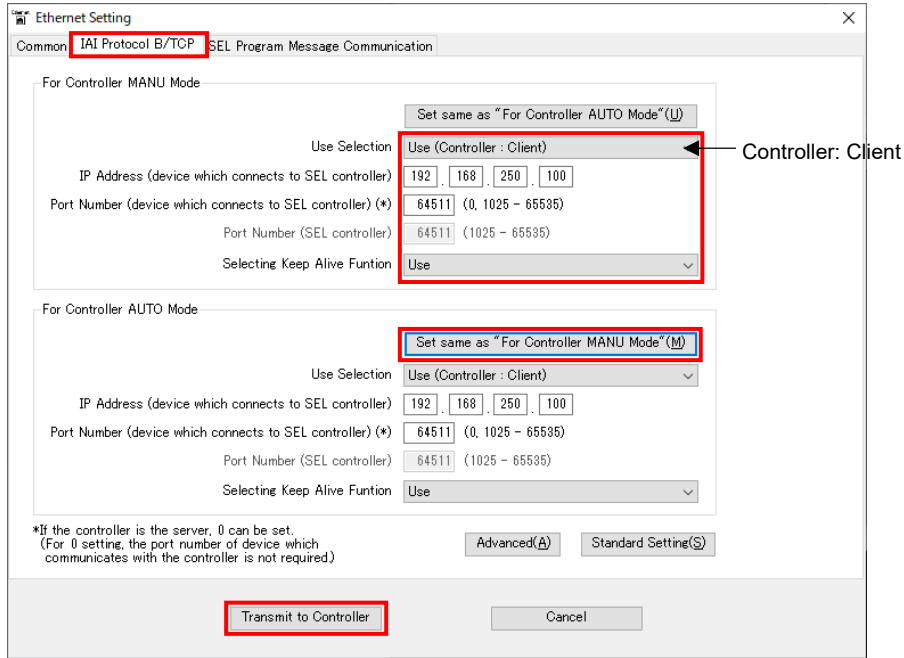

- As the confirmation window should appear, transfer the parameter setting to the controller.

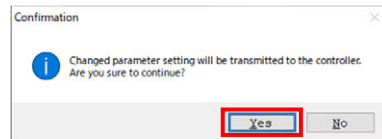

As the confirmation window should appear after the transfer is complete, click **OK**.

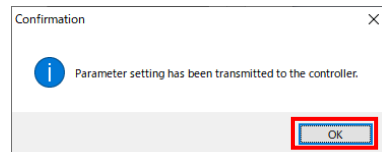

6. Close the parameter simple setup window, and write the parameters in the flash ROM.

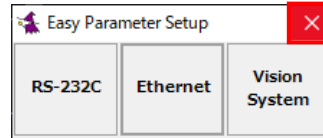

Remove a check mark →

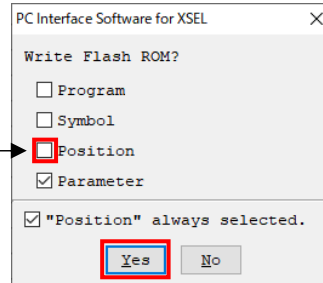

7. Reboot the controller after writing the parameters to the flash ROM.

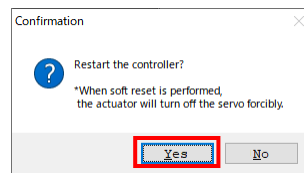

That is all for the parameter setup.



Caution

- In order to activate the parameter that was set up, it is necessary to have flash ROM writing and controller reboot (software reset).

[2] Connection confirmation

1) Selecting the communication port

Select "Ethernet (PC: Server)" in the communication port list in the connection confirmation window for the PC software version V13.0.0.0 and later.

Select "Ethernet" for the PC software version earlier than V13.0.0.0.

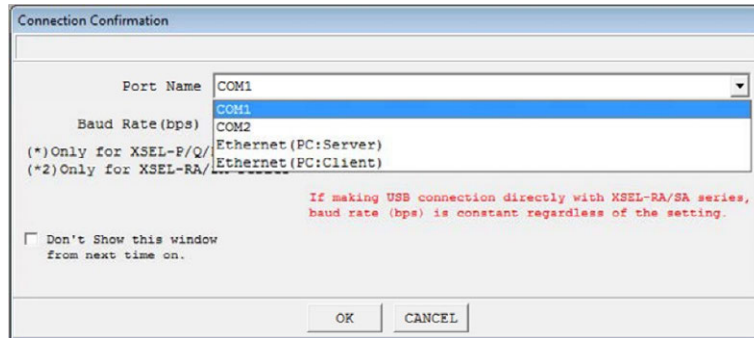

2) Entering the port number (PC)

Selecting "Ethernet (PC: Server)" will change the field label "Baud Rate (bps)" to "Port No. (PC)".

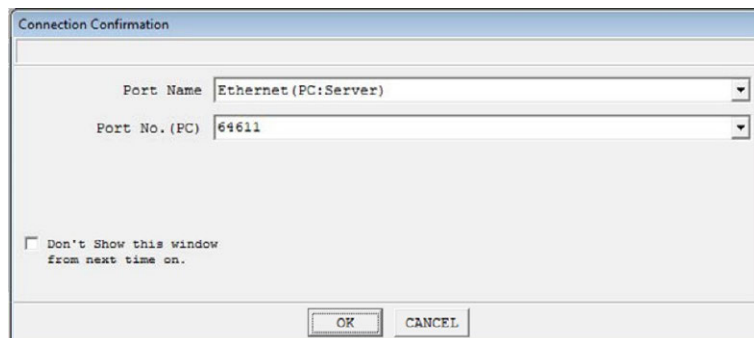

Input the standby port number for the XSEL PC software (Server) to "Port No. (PC)." The number should match the port number specified in I/O parameter No. 153 (MANU mode) or No. 158 (AUTO mode).

* Enter a number between 1025 and 65535 not already used in another application.

3) Selecting the controller

Entering the port number and clicking the **OK** switches the display to the Select Controller screen.

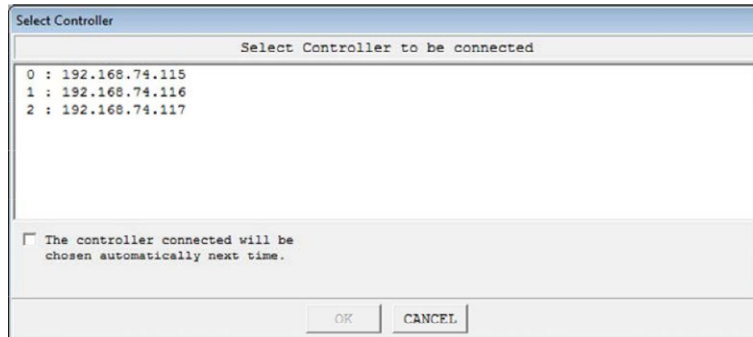

Each time a connection is established from a controller, the IP address of the connecting controller is added to the list. Select the IP address of the controller to be connected, and then click the **OK**.

Communication will be established with the selected controller and the application will start in the online mode.

Clicking the **CANCEL** will activate the offline mode. Even after the application is started in the offline mode, you can still switch to the online mode through “reconnection”.

If the checkbox “The controller connected will be chosen automatically next time.” is selected, the application will automatically establish connection with the controller that was connected first.

* Check this option only when you are communicating with a single controller or using peer-to-peer connection.

[3] Connection destination change

If you want to switch between multiple controllers, the connecting controller can be changed via the following procedure.

Select “Controller” → “Request Release Pause” from the menu.

* This menu item will be added only when connections have been established from two or more controllers.

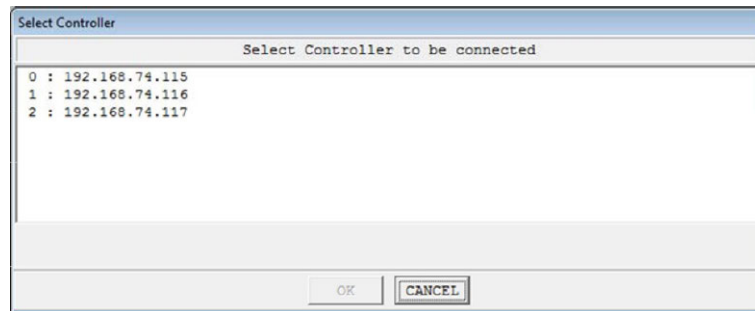

Select the IP address of the controller to be connected, and then click the **OK** .
Communication will be established with the selected controller.

5.2.4 When Using PC (XSEL PC Software) as Client

Note It is applicable for client in the PC software version V13.0.0.0 and later.

[1] Parameter setting

Establish the settings of the Parameters in advance as shown below:

[I/O parameters]

No.	Name	Setting value
124	Network attribute 5	Set Bits 0 to 3 "IAI protocol B/TCP (MANU mode)" and Bits 4 to 7 "IAI protocol B/TCP (AUTO mode)" to "3: Server (specify own port number)". (Set Bits 0 to 3 when communication in MANU mode and set Bits 4 to 7 when communication in AUTO mode)
132-135	Own IP address	IP Address on Controller (Setting to be established for controllers other than XSEL-RA/SA/RAX/SAX/RAXD/SAXD and RSEL system (SEL unit))
136-139	Subnet mask	Subnet Mask for Network Environment of Your Use (Setting to be established for controllers other than XSEL-RA/SA/RAX/SAX/RAXD/SAXD and RSEL system (SEL unit))
140-143	Default gateway	Default Gateway for Network Environment of Your Use (Setting to be established for controllers other than XSEL-RA/SA/RAX/SAX/RAXD/SAXD and RSEL system (SEL unit))
144	IAI protocol B/TCP: Own port number (MANU mode)	Standby Port Number on Controller (Server) (Setting to be established when communication in MANU mode)
149-152	IAI protocol B/TCP: IP address of connection destination (MANU mode)	IP Address of PC to communicate with Controller (Setting to be established when communication in MANU mode)
153	IAI protocol B/TCP: Port number of connection destination (MANU mode)	0 (Ignore port number of connection destination) (Setting to be established when communication in MANU mode)
154-157	IAI protocol B/TCP: IP address of connection destination (AUTO mode)	IP Address of PC to communicate with Controller (Setting to be established when communication in AUTO mode)
158	IAI protocol B/TCP: Port number of connection destination (AUTO mode)	0 (Ignore port number of connection destination) (Setting to be established when communication in AUTO mode)
159	IAI protocol B/TCP: Own port number (AUTO mode)	Standby Port Number on Controller (Server) (Setting to be established when communication in AUTO mode)
172-175	Ethernet I/F own IP address	IP Address on Controller (Setting to be established for controllers other than XSEL-RA/SA/RAX/SAX/RAXD/SAXD and RSEL system (SEL unit))
176-179	Ethernet I/F subnet mask	Subnet Mask for Network Environment of Your Use (Setting to be established for controllers other than XSEL-RA/SA/RAX/SAX/RAXD/SAXD and RSEL system (SEL unit))
180-183	Ethernet I/F default gateway	Default Gateway for Network Environment of Your Use (Setting to be established for controllers other than XSEL-RA/SA/RAX/SAX/RAXD/SAXD and RSEL system (SEL unit))

[How to set up Parameters in Simple Setup]

Here, explains how to establish setup using the parameter simple setup window.

1. From "Parameter" in the main menu window, click **Easy Parameter Setup**.

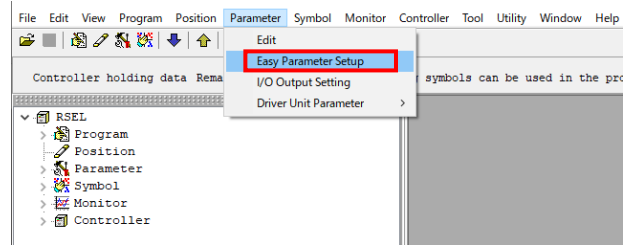

2. As the parameter simple setup window shows up, click **Ethernet**.

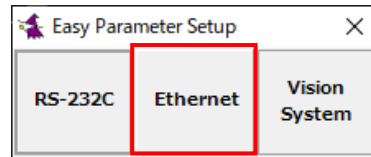

3. Input values to be set in "IP Address (SEL controller)", "Subnet Mask" and "Default Gateway" from Common in the Ethernet Setup window.

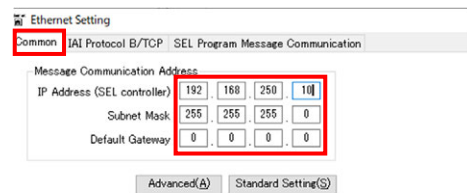

Caution

- Make sure the IP address would not duplicate with another device in the same network when the setup is established.

- Click "IAI Protocol B/TCP" in the Ethernet Setup window, select or input each item. By clicking **Set same as "For Controller MANU Mode" (M)**, the setting in AUTO Mode can be made the same as the one input in MANU Mode. After the setup is complete, click **Transmit to Controller**.

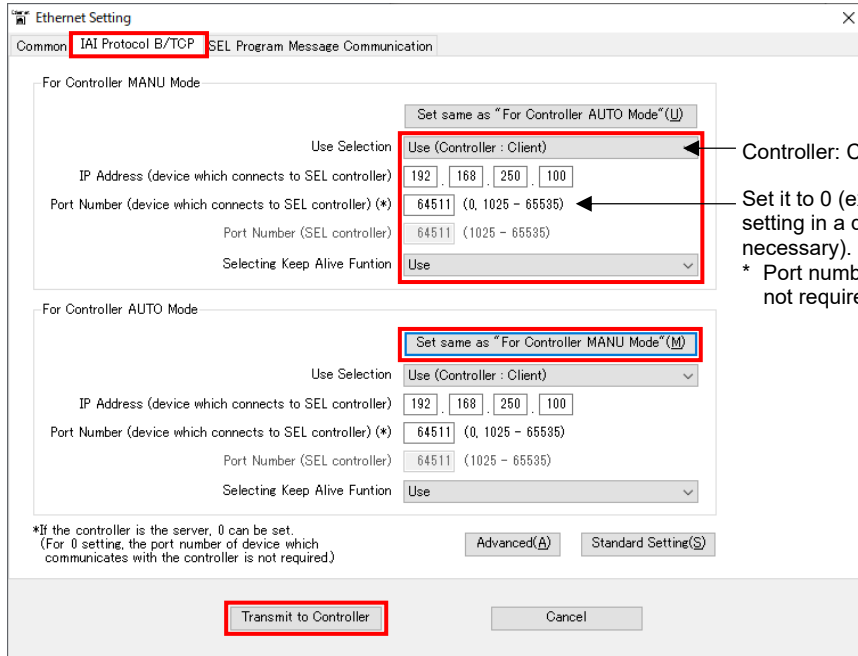

Controller: Client
 Set it to 0 (except for cases when setting in a device to connect to is necessary).
 * Port number for connected device not required when set to 0

- As the confirmation window should appear, transfer the parameter setting to the controller.

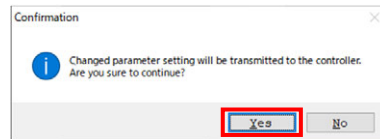

As the confirmation window should appear after the transfer is complete, click **OK**.

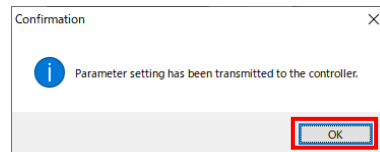

6. Close the parameter simple setup window, and write the parameters in the flash ROM.

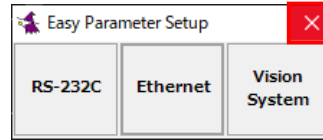

Remove a check mark →

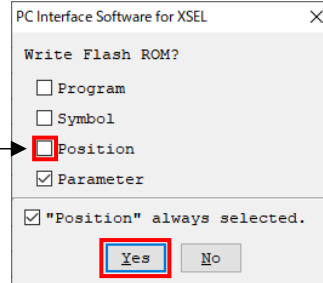

7. Reboot the controller after writing the parameters to the flash ROM.

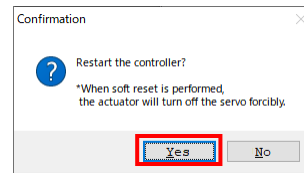

That is all for the parameter setup.



Caution

- In order to activate the parameter that was set up, it is necessary to have flash ROM writing and controller reboot (software reset).

[2] Connection confirmation

1) Selecting the communication port

Select "Ethernet (PC: Client)" in the port name list on the Connection Confirmation screen.

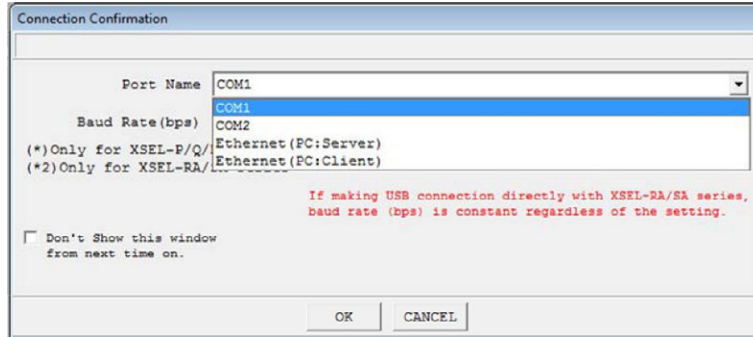

2) Entering the IP address and port number (controller)

Select "Ethernet (PC: Client)" and the window displays as shown below.

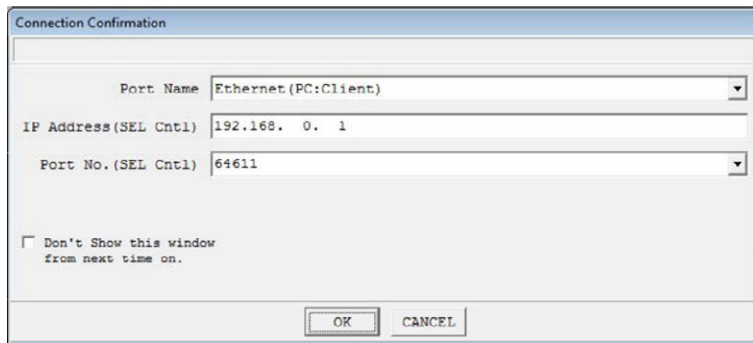

Input the IP address of the destination controller for connection (server) to "IP Address (SEL Cnt1)".

Input the same IP address as that indication in I/O Parameters No. 132 to 135 "Own IP Address" when connected to controllers other than XSEL-RA/SA/RAX/SAX/RAXD/SAXD and RSEL system (SEL unit), and as that indicated in I/O Parameter No. 172 to 175 "Ethernet I/F Own IP Address" when connected to XSEL-RA/SA/RAX/SAX/ RAXD/SAXD controllers and RSEL system (SEL unit).

Input the standby port number of the destination controller for connection (server) to "Port No. (SEL Cnt1)."

The number should match the port number specified in I/O parameter No. 144 (MANU mode) or No. 159 (AUTO mode).

* Enter a number between 1025 and 65535 not already used in another application.

Input the port number and IP address of the destination controller for connection, and click to start communication with the controller and start up the application in the online mode.

The following message will appear when connection to the controller is failed. Check if there is anything wrong in the setting established in IP Address (SEL Cnt1) or Port No. (SEL Cnt1).



5.3 How to Check Operation of IAI Protocol B/TCP by Telnet Client

When a program controller is a server, operation check by the telnet service in Windows can be conducted.

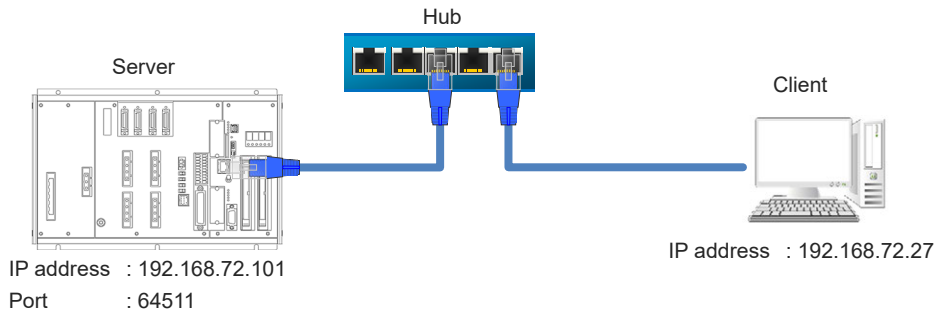

[How to Check]

* Start up in advance the command line tool such as a command prompt.

1) Start up the Telnet Service. Input "Telnet" and press the Enter key.

```

Command Prompt
Microsoft Windows [Version 10.0.19044.1826]
(c) Microsoft Corporation. All rights reserved.

C:\Users\User>telnet_

```

2) Input "set localecho" and press the Enter key.
Activate the local echo.

```

Command Prompt - telnet
Welcome to Microsoft Telnet Client
Escape Character is 'CTRL+]'
Microsoft Telnet: set localecho_

```



```

Microsoft Telnet> set localecho
Local echo on
Microsoft telnet> _

```

- 3) Input "open 192.168.250.100.64551" and press the Enter key.
(Connect to IP address: 192.168.250.100, Port No. 64551.)

```
telnet 192.168.250.100
Welcome to Microsoft Telnet Client
Escape Character is 'CTRL+]'
Microsoft Telnet> set localecho
Local echo on
Microsoft Telnet> open 192.168.250.100 64551
```



```
Microsoft Telnet> set localecho
Local echo on
Microsoft Telnet> open 192.168.250.100 64551
Connecting To 192.168.250.100...
```

Confirmation of Connection

- 4) Send an IAI Protocol B "Test Call" command message to the program controller.
Input "!992001234567890@@" and press the Enter key.

```
!992001234567890@@
```

- 5) Receiving Response from Program Controller

Below shows an example of when "Test Call" of IAI Protocol B has been received in normal condition.

```
!992001234567890@@
#99200123456789034
```

* "Telnet" is easy to handle with "local echo activated".

Ethernet

Chapter 6

Transmission by SEL Program

6.1	Setup of Ethernet Environment	6-2
6.2	Related Parameters I/O Parameters	6-3
6.2.1	Standard Ethernet Port for XSEL-RA/SA/RAX/SAX/RAXD/SAXD and RSEL System (SEL unit)	6-3
6.2.2	XSEL-J/K/JX/KX/P/Q/PX/QX Interface Board (Option)	6-4
6.3	Message Communication with SEL Program (Non-Procedure Communication)	6-6
6.3.1	List of SEL Commands	6-6
6.3.2	Details of SEL Commands	6-7

Four channels of ASCII-based, delimiter-controlled communication (CH31 through CH34) are supported, using a set of transmission commands in a system roughly equivalent to that used in the XSEL controller's serial communication.

(The specification of each SEL command may vary slightly from the corresponding command specification in serial communication, so exercise due caution.)

* Data transmission is performed by SEL program based on the specifications of the following items:

- CH (channel) selection
- IP address of connection destination
- Port number

For program details, refer to [6.3 Message Communication with SEL Program (Non-Procedure Communication)].

6.1 Setup of Ethernet Environment

Set I/O parameter No. 129 “Network attribute 10 (bits 4 to 7)” to “1: Use TCP/IP message communication”. In addition, I/O Parameter No. 124 “Network attribute 5 bits 8 to 11 (CH31), bits 12 to 15 (CH32), bits 16 to 19 (CH33) or bits 20 to 23 (CH34)” is set to “1: Client (Assign own port number automatically)” or “3: Server (Specify own port number)” selects the transmission function by SEL program.

No.	Parameter name	Setting value	Input range	Remarks
124	Network attribute 5	MANU mode 1 _H or 3 _H AUTO mode 10 _H or 30 _H	0 _H ~ FFFFFFF _H	<p>Ethernet TCP/IP message communication attribute Ethernet client/server type</p> <p>0: Do not use 1: Client (Assign own port number automatically) 2: System reservation 3: Server (Specify own port number) Note: Number of clients that can be connected to one server-port channel simultaneously = 1</p> <p>Bits 0 to 3: IAI protocol B/TCP (MANU mode) Bits 4 to 7: IAI protocol B/TCP (AUTO mode) Bits 8 to 11: User-open channel 31 Bits 12 to 15: User-open channel 32 Bits 16 to 19: User-open channel 33 Bits 20 to 23: User-open channel 34</p> <p>* IAI protocol B/TCP MANU/AUTO The connection will be cut off briefly during switching between the MANU and AUTO modes, if the parameter settings of “own port number”, “client/server type”, “IP address of connection destination” and “port number of connection destination” do not fully correspond between the two modes.</p>
129	Network attribute 10	10 _H	0 _H ~ FFFFFFF _H	<p>Ethernet operation requirement</p> <p>Bits 0 to 3: Remote I/O * Dependent to controller type</p> <p>Bits 4 to 7: TCP/IP message communication 0: Do not use 1: Use</p> <p>Bits 8 to 31: Reserve (Ethernet operation requirement)</p>

6.2 Related Parameters I/O Parameters

6.2.1 Standard Ethernet Port for XSEL-RA/SA/RAX/SAX/RAXD/SAXD and RSEL System (SEL unit)

[I/O parameters]

No.	Parameter name	Setting value	Input range	Remarks
124	Network attribute 5	(MANU mode) 1 _H or 3 _H (AUTO mode) 10 _H or 30 _H	0 _H ~ FFFFFFF _H	<p>Ethernet TCP/IP message communication attribute Ethernet client/server type 0: Do not use 1: Client (Assign own port number automatically) 2: System reservation 3: Server (Specify own port number) Note: Number of clients that can be connected to one server-port channel simultaneously = 1</p> <p>Bits 0 to 3: IAI protocol B/TCP (MANU mode) Bits 4 to 7: IAI protocol B/TCP (AUTO mode) Bits 8 to 11: User-open channel 31 Bits 12 to 15: User-open channel 32 Bits 16 to 19: User-open channel 33 Bits 20 to 23: User-open channel 34</p> <p>* IAI protocol B/TCP MANU/AUTO The connection will be cut off briefly during switching between the MANU and AUTO modes, if the parameter settings of "own port number", "client/server type", "IP address of connection destination" and "port number of connection destination" do not fully correspond between the two modes.</p>
129	Network attribute 10	10 _H	0 _H ~ FFFFFFF _H	<p>Ethernet operation requirement Bits 0 to 3: Remote I/O * Dependent to controller type Bits 4 to 7: TCP/IP message communication 0: Do not use 1: Use Bits 8 to 31: Reserve (Ethernet operation requirement)</p>
172	Ethernet I/F Own IP address (H)	192	1 ~ 255	* Setting of "0" and "127" is prohibited.
173	Ethernet I/F Own IP address (MH)	168	0 ~ 255	
174	Ethernet I/F Own IP address (ML)	0	0 ~ 255	
175	Ethernet I/F Own IP address (L)	1	1 ~ 254	* Setting of "0" and "255" is prohibited.
176	Ethernet I/F Subnet mask (H)	255	0 ~ 255	
177	Ethernet I/F Subnet mask (MH)	255	0 ~ 255	
178	Ethernet I/F Subnet mask (ML)	255	0 ~ 255	
179	Ethernet I/F Subnet mask (L)	0	0 ~ 255	
180	Ethernet I/F Default gateway (H)	0	0 ~ 255	
181	Ethernet I/F Default gateway (MH)	0	0 ~ 255	
182	Ethernet I/F Default gateway (ML)	0	0 ~ 255	
183	Ethernet I/F Default gateway (L)	0	0 ~ 255	

6.2.2 XSEL-J/K/JX/KX/P/Q/PX/QX Interface Board (Option)

[I/O parameters]

No.	Parameter name	Setting value	Input range	Remarks
124	Network attribute 5	00***100 _H (Channel 31) 00**1*00 _H (Channel 32) 00*1**00 _H (Channel 33) 001***00 _H (Channel 34) or 00***300 _H (Channel 31) 00**3*00 _H (Channel 32) 00*3**00 _H (Channel 33) 003***00 _H (Channel 34)	0 _H ~ FFFFFFF _H	Ethernet TCP/IP message communication attribute Ethernet client/server type 0: Do not use 1: Client (Assign own port number automatically) 2: Client (Specify own port number) ▲Note: As this setting has a device restriction that an error would occur when a close response cannot be confirmed due to such a reason as power supply cutoff at the mating device and open for approximately 10 minutes afterwards, it is not recommended. 3: Server (Specify own port number) Note: Number of clients that can be connected to one server-port channel simultaneously = 1 Bits 0 to 3: IAI protocol B/TCP (MANU mode) Bits 4 to 7: IAI protocol B/TCP (AUTO mode) Bits 8 to 11: User-open channel 31 Bits 12 to 15: User-open channel 32 Bits 16 to 19: User-open channel 33 Bits 20 to 23: User-open channel 34 * IAI protocol B/TCP MANU/AUTO The connection will be cut off briefly during switching between the MANU and AUTO modes, if the parameter settings of "own port number", "client/server type", "IP address of connection destination" and "port number of connection destination" do not fully correspond between the two modes.
⋮	⋮	⋮	⋮	⋮
129	Network attribute 10	10 _H	0 _H ~ FFFFFFF _H	Ethernet operation requirement Bits 0 to 3: Remote I/O 0: Do not use 1: Use Modbus/TCP (EXCEPTION status invalid) 2: Use Modbus/TCP (EXCEPTION status valid) 3: Use EtherNet/ IP Bits 4 to 7: TCP/IP message communication 0: Do not use 1: Use Bits 8 to 31: Not used
130	Own MAC address (H)	0030 _H	Reference value (HEX)	Only the lower two bytes are valid. (This parameter is not settable.)
131	Own MAC address (L)	11 _H	Reference value (HEX)	(This parameter is not settable.)
132	Own IP address (H)	192	1 ~ 255	* Setting of "0" and "127" is prohibited.
133	Own IP address (MH)	168	0 ~ 255	
134	Own IP address (ML)	0	0 ~ 255	
135	Own IP address (L)	1	1 ~ 254	* Setting of "0" and "255" is prohibited.
136	Subnet mask (H)	255	0 ~ 255	
137	Subnet mask (MH)	255	0 ~ 255	
138	Subnet mask (ML)	255	0 ~ 255	

No.	Parameter name	Setting value	Input range	Remarks
139	Subnet mask (L)	0	0 ~ 255	
140	Default gateway (H)	0	0 ~ 255	
141	Default gateway (MH)	0	0 ~ 255	
142	Default gateway (ML)	0	0 ~ 255	
143	Default gateway (L)	0	0 ~ 255	

6.3 Message Communication with SEL Program (Non-Procedure Communication)

6.3.1 List of SEL Commands

Category	Condition	Command	Operand 1	Operand 2	Output	Function
Communication	Optional	OPEN	Channel No.	Prohibited	CP	Open channel
	Optional	CLOS	Channel No.	Prohibited	CP	Close channel
	Optional	READ	Channel No.	Column number	CC	Input from channel
	Optional	TMRW	Read timer setting	Prohibited	CP	Set READ/WRIT timeout value
	Optional	TMRD	Timer period	Prohibited	CP	Set READ timeout value
	Optional	WRIT	Channel No.	Column number	CP	Output to channel
	Optional	SCHA	Character code	Prohibited	CP	Character setting for sending and receiving
	Optional	IPCN	Channel No.	Integer variable number	CP	IP address/port number settings of connection destination
Timer	Optional	TIMC	Program No.	Prohibited	CP	Cancel waiting

* Output operation types

CC: Command successful, CP: Command passing

* XSEL-J/JX, XSEL-K/KE/KT/KET/KX/KETX support the “Ethernet SEL commands” in the following versions.

- XSEL (Cartesian) Main Application V0.79 or later
- XSEL (IX SCARA) Main Application V0.29 or later

* The XSEL PC teaching software supports it in Ver. 2.1.1.0 and later.



Caution

- The following controller if “Open 0” is executed the teaching pendant connector (D-sub25 pin) is cut off. (This is because channel 0 is used by both the teaching pendant and PC software.)

XSEL-P/Q/PCT/QCT/PX/QX/R/S/RX/SX/RXD/SXD/RA/SA/RAX/SAX/RAXD/SAXD,
ASEL/PSEL/SSEL, RSEL

- The following controller if “Open 1” is executed the teaching pendant connector (D-sub25 pin) is cut off. (This is because channel 1 is used by both the teaching pendant and PC software.)

XSEL-J/JX, XSEL-K/KE/KT/KET/KX/KETX, TT, TTA, MSEL

6.3.2 Details of SEL Commands

[1] OPEN (Channel open) * When the Ethernet is used

Extension condition (LD, A, O, AB, OB)	Input condition (I/O, flag)	Command, declaration			Output (Output, flag)
		Command, declaration	Operand 1	Operand 2	
E	N, Cnd	Cmnd	Operand1	Operand2	Pst
Optional	Optional	OPEN	Channel No.	Prohibited	CP

Applicable models
All models

[Function] Open the channel specified in operand 1.

Transmission via the specified channel will hereafter be enabled.

Before executing this command, the end character must be set with an SCHA command and the IP address/port address of connection destination with an IPCN command.

Note 1 Channel Nos. 31 through 34 can be specified in operand 1 with the Ethernet.

Up to four channels can be opened simultaneously.

Note 2 Be sure to design the program in such a way that the normal completion or abnormal completion of the return code will always be confirmed before moving on to the next process.

Note 3 To change the connection destination, the channel must be closed once using a "CLOS" command.

It may take approximately four seconds to reopen the closed channel.

Executing an OPEN command for a given channel while the channel is already open will generate a B1B "Ethernet socket open-without-close error".

Note 4 To avoid occurrence of system trouble, it is recommended that the system be built by ensuring a sufficient period so that the port opening order of the connected device and controller will satisfy server port open → client port open.

(1) Server open

Opens the port and waits for a connection request from the client (specified with an IPCN command).

(2) Client open

Opens the port and issues a connection request to the server (specified with an IPCN command).

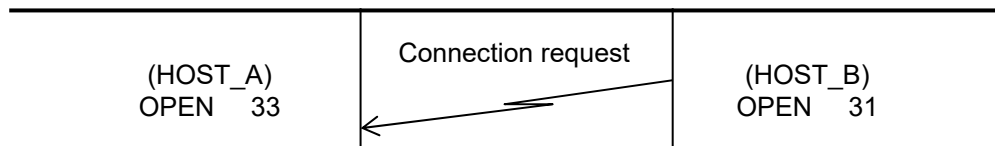

- Note 5 When the controller is used as a server, the number of clients that can be connected to one server-port channel simultaneously is 1.
- Note 6 If a firewall (including the firewall function of virus protection software) is installed in the PC, etc., the port block must be canceled or the firewall function disabled before a connection can be made. (This is because the very purpose of firewall software is to block external connection to the protecting device.)
- Note 7 The client/server mode is determined upon reset via I/O parameter No. 124 "Network attribute 5, bits 8 to 11 (CH31), bits 12 to 15 (CH32), bits 16 to 19 (CH33) or bits 20 to 23 (CH34)". The controller cannot be used during dynamic switching between the client and server modes.
- Note 8 The diagram below explains the mechanism of "socket interface".
 * Bear in mind that "socket", "connect", "write", "read", "close", "bind", "listen" and "accept" are not SEL language commands (SEL commands).

(1) Client open

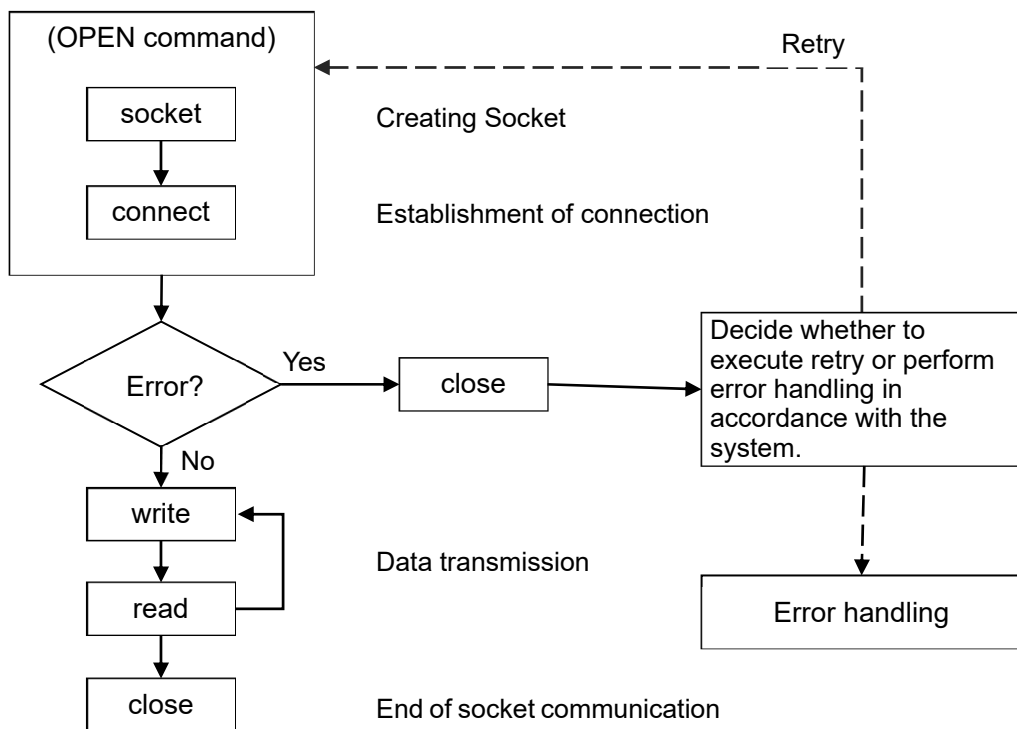

(2) Server open

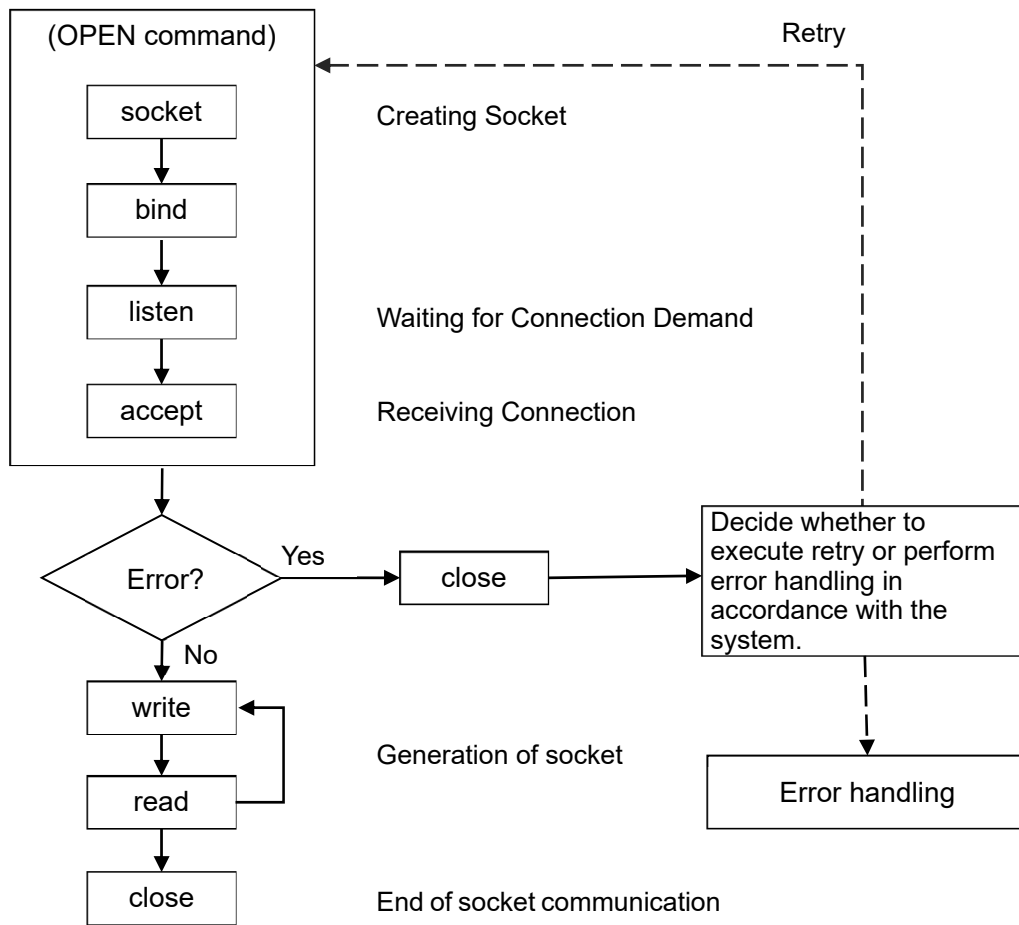

[Return code of the OPEN command]

The return code is stored in the local variable specified in other parameter No. 24 the default setting is variable 99.

Return code	Contents	Remarks
0	OPEN completed successfully	Terminated in normal condition.
1	OPEN timeout	Timed out. The duration of timeout can be adjusted in the following parameters. <ul style="list-style-type: none"> I/O Parameter No. 127 "Network Attribute 8 (Bit 0-7)" when SEL controller is used as client I/O Parameter No. 128 "Network Attribute 9 (Bit 0-15)" when SEL controller is used as server
2	OPEN cancel timer	The timer has been cancelled by such as TIMC Command from another program.
5	OPEN factor error	A program compulsory termination error has occurred. (This error cannot be recognized through SEL commands.)
6	OPEN end task	There was such as a compulsory termination request of a program. (This error cannot be recognized through SEL commands.)
15	OPEN connection error	Connection from the mating device has been cut. Execute CLOS Command and then OPEN Command again.
16	OPEN other command error	A controller internal error has occurred. Execute CLOS Command and then OPEN Command again.
17	OPEN other error	
18	OPEN Job Compulsorily Terminated Error	
19	OPEN Socket Generation Command Failure Error	There was a failure in generating a socket. Execute CLOS Command and then OPEN Command again.
20	OPEN No vacant Socket Error	
50 ~	OPEN device error	There was an Ethernet device error. Execute CLOS Command and then OPEN Command again.

The detail of Return Code 50 is shown in the following page.

- 50 ~: Device error information
 - 50 Invalid Message ID
 - 51 Invalid Message Type
 - 52 Invalid Command
 - 53 Invalid Data Size
 - 54 Invalid Frame Count
 - 55 Invalid Frame Number
 - 56 Invalid Offset
 - 57 Invalid Address
 - 58 Invalid Response
 - 59 Flash Config Error
 - 60 ~ 64 Invalid To Be Defined 1-7
 - 101 Invalid IP-address or Subnet mask
 - 102 Invalid socket type
 - 103 No free socket
 - 104 Invalid socket
 - 105 Not connected
 - 106 Command failed
 - 107 Invalid data size
 - 108 Invalid fragment type
 - 109 Fragment error
 - 110 Invalid timeout time
 - 111 Can't send more
 - 112 ~ 115 (reserved)
 - 116 Command aborted
 - 117 Too many registered objects
 - 118 Object already registered
 - 119 Deregistering invalid objects
 - 121 Unsupported Command
 - 122 (reserved)
 - 123 No timeout
 - 124 Invalid port number
 - 125 Duplicate port number
 - 126 (reserved)
 - 127 Mapping Failed
 - 128 Reset notification unsupported

6.3 Message Communication with SEL Program (Non-Procedure Communication)

[Example for SEL Program]

No.	E	N	Cnd	Cmnd	Operand1	Operand2	Pst	Comment
1				LET	90	192		IP address of connection destination (H) = 192
2				LET	91	168		IP address of connection destination (MH) = 168
3				LET	92	72		IP address of connection destination (ML) = 72
4				IET	93	101		IP address of connection destination (L)= 101
5				LET	94	64514		Port number of connection destination = 64514
6				IPCN	31	90		Declare the IP address/port number storage area for the connection destination of channel 31 = Local integer variable between 90 to 94.
7				SCHA	10			Set 10 (=LF) as the end character.
8				OPEN	31		990	Open channel 31.
9				TRAN	1	99		Store the return code in variable 1.
10		N	990	GOTO	15			OPEN failed → Proceed to error handling or retry process after closing.

[2] CLOS (Channel close) * When the Ethernet is used

Extension condition (LD, A, O, AB, OB)	Input condition (I/O, flag)	Command, declaration			Output (Output, flag)
		Command, declaration	Operand 1	Operand 2	
E	N, Cnd	Cmnd	Operand1	Operand2	Pst
Optional	Optional	CLOS	Channel No..	Prohibited	CP

Applicable models
All models

[Function] Close the channel specified in operand 1.

Transmission via the specified channel will hereafter be disabled.

Note 1 Channel No. 31 through 34 can be specified in operand 1 with the Ethernet.

[Example for SEL Program]

Cmnd	Operand 1	Operand 2	
CLOS	31	11	Close channel 31.
LET	1	32	Assign 32 to variable 1.
CLOS	*1		Close the content of variable 1 (channel 32).

[3] READ (Read) * When the Ethernet is used

Extension condition (LD, A, O, AB, OB)	Input condition (I/O, flag)	Command, declaration			Output (Output, flag)
		Command, declaration	Operand 1	Operand 2	
E	N, Cnd	Cmnd	Operand1	Operand2	Pst
Optional	Optional	READ	Channel No..	Column No.	CC

Applicable models
All models

[Function] Read a character string from the channel specified in operand 1 to the column specified in operand 2.

The reading will end upon reaching the character specified with a SCHA command.

Either a local or global column may be specified.

A return code will be stored in a local variable (variable 99 under the factory setting) immediately after this command is executed.

Whether or not the command has been executed successfully can be checked based on this return code. Define appropriate processing to handle situations where the command execution failed due to an error.

Note 1 Channel No. 31 through 34 can be specified in operand 1 with the Ethernet.

Note 2 Be sure to design the program in such a way that the normal completion or abnormal completion of the return code will always be confirmed before moving on to the next process.

Note 3 A READ command must be executed before the other side sends the end character.

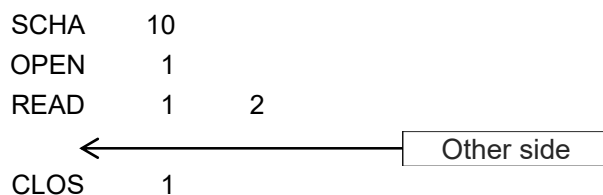

Note 4 Dummy read (operand 2: 0) cannot be specified for channel No. 31 to 34 (Ethernet).

[Return code of the READ command]

The return code is stored in the local variable specified in Other parameter No. 24. The default setting is variable 99.

Return code	Contents	Remarks
0	READ completed successfully	Terminated in normal condition.
1	READ timeout	Timed out. The duration of timeout can be adjusted in TMRW (TMRD) Command.
2	READ timer cancelled	The timer has been cancelled by such as TIMC Command from another program.
5	READ factor error	A program compulsory termination error has occurred. (This error cannot be recognized through SEL commands.)
6	READ task ended	There was such as a compulsory termination request of a program. (This error cannot be recognized through SEL commands.)
13	READ receive buffer overflow error	The receiving data buffer in SEL controller has overflowed. Execute CLOS Command and then OPEN Command again.
15	READ connection error	Connection from the mating device has been cut. Execute CLOS Command and then OPEN Command again.
16	READ other command error	A controller internal error has occurred. Execute CLOS Command and then OPEN Command again.
17	READ other error	
18	READ Job Compulsorily Terminated Error	
50 ~	READ device error	There was an Ethernet device error. Execute CLOS Command and then OPEN Command again.

6.3 Message Communication with SEL Program (Non-Procedure Communication)

[Example for SEL Program]

No.	E	N	Cnd	Cmnd	Operand1	Operand2	Pst	Comment
				SCHA	10			Set 10 (=LF) as the end character.
				OPEN	31			Open channel 31.
				...				
				READ	1	2		Read a character string from channel 31 to column 2 until LF is reached.
				TRAN	1	99		Store the return code (variable 99) in variable 2.
				CLOS	31			Close the channel 31.
				SLTC				The processing flow branches out in accordance with each return code. Note Using a GOTO command to branch out of an SLCT-EDSL syntax or to other branch processing within the syntax is prohibited.
				WHEQ	1	0		If the content of variable "1" is "0" (Completed successfully), (1) will be executed.
				:				
				(1)				In (1), define the processing that should take place upon successful command execution.
				:				
				WHEQ	1	1		If the content of variable "1" is "1" (Timeout), (2) will be executed. * In (2), define appropriate processing to handle this situation, if necessary.
				:				
				(2)				In (2) describes measures when timeout occurs.
				:				
				WHEQ	1	2		If the content of variable "1" is "2" (Timer cancelled), (3) will be executed. * In (3), define appropriate processing to handle this situation, if necessary.
				:				
				(3)				In (3) describes measures when timer cancelled.
				:				
				OTHE				If the content of variable "1" is not "0", "1" or "2", (4) will be executed. * In (4), define appropriate processing to handle this situation, if necessary.
				:				
				(4)				In (4), define appropriate error handling.
				:				
				EDSL				Once one of the specified conditions was met and the corresponding command has been executed, the processing will move here.

[4] TMRW (Set READ/WRIT timeout value) * When the Ethernet is used

Extension condition (LD, A, O, AB, OB)	Input condition (I/O, flag)	Command, declaration			Output (Output, flag)
		Command, declaration	Operand 1	Operand 2	
E	N, Cnd	Cmnd	Operand1	Operand2	Pst
Optional	Optional	TMRW	Read timer setting	Prohibited	CP

Applicable models
XSEL2, RSEL, XSEL-P/Q/PCT/QCT, XSEL-R/S, XSEL-RA/SA XSEL-PX/QX, XSEL-RX/SX/RXD/SXD, XSEL-RAX/SAX/RAXD/SAXD ASEL/PSEL/SSEL, TTA, MSEL

[Function] Set the timeout to be applied to a READ command.

The timer setting specified in operand 1 will set the maximum time the program will wait for the character string read to end when a READ command is executed.

If the end character could not be read before the timer is up during the execution of the READ command, a timeout will occur and the program will move to the next step.

* You can check if a timeout has occurred by checking the return code which is stored in a local variable (factory setting: variable 99) immediately after the READ command has been executed.

If the timer period is set to 0, the READ command causes the program to wait infinitely until the end characters are read, by assuming that there is no timeout.

The timer setting is input in [s]. Values are valid up to two decimal places (setting range: 0 to 99.00s).

A variable can be specified indirectly in operand 1.

Note 1 TMRW is set to "0" in the default condition before TMRW setting is performed.

Note 2 WRIT Timeout during Ethernet should be performed with I/O Parameter No. 127 "Network Attribute 8 (Bit 16-23)". Operation 2 in TMRW Command will be disregarded.

[Example for SEL Program]

Read completes successfully within 30s → Variable No. 1 = 0

Timeout occurs → Variable No. 1 = 1

No.	E	N	Cnd	Cmnd	Operand1	Operand2	Pst	Comment
				...				
				...				
				SCHA	10			Set 10 (=LF) as the end character.
				TMRW	30			Set the READ timeout value to 30s.
				...				
				OPEN	31			Open channel 31.
				READ	31	2		Read the character string from channel 31 to column 2 until LF is read.
				TRAN	1	99		Assign the return code to variable 1.
				CLOS	31			Close the channel 31.

* The return code of READ command may not be limited to 0 or 1.

The variable to store the return code can be set in "Other parameter No. 24".

Refer to the [explanation of READ command] for details.

[5] TMRD (Set READ timeout value)

Extension condition (LD, A, O, AB, OB)	Input condition (I/O, flag)	Command, declaration			Output (Output, flag)
		Command, declaration	Operand 1	Operand 2	
E	N, Cnd	Cmnd	Operand1	Operand2	Pst
Optional	Optional	TMRD	Timer	Prohibited	CP

Applicable models
XSEL-J/K/KE/KT/KET, XSEL-JX/KX/ KTX, TT

[Function] Set the timeout to be applied to a READ command.

The timer setting specified in operand 1 will set the maximum time the program will wait for the character string read to end when a READ command is executed.

If the end character could not be read before the timer is up during the execution of the READ command, a timeout will occur and the program will move to the next step.

* You can check if a timeout has occurred by checking the return code which is stored in a local variable (factory setting: variable 99) immediately after the READ command has been executed. If necessary, program an appropriate processing to be performed when a timeout occurs.

Setting the timer to "0" will allow the READ command to wait infinitely, without timeout, until the end character is read.

The timer setting is input in seconds (setting range: 0 to 99.00s) including up to two decimal places.

Note TMRD is set to "0" in the default condition before TMRD setting is performed.

[Example for SEL Program]

Read completes successfully within 30s → Variable No. 1 = 0

Timeout occurs → Variable No. 1 = 1

No.	E	N	Cnd	Cmnd	Operand1	Operand2	Pst	Comment
				...				
				...				
				SCHA	10			Set 10 (=LF) as the end character.
				TMRD	30			Set the READ timeout value to 30s.
				...				
				OPEN	31			Open channel 31.
				READ	31	2		Read the character string from channel 31 to column 2 until LF is read.
				TRAN	1	99		Assign the return code to variable 1.
				CLOS	31			Close the channel 31.

* The return code of READ command may not be limited to 0 or 1.

The variable to store the return code can be set in "Other parameter No. 24".

For details, refer to the explanation of the READ command.

[6] WRIT (Write) * When the Ethernet is used

Extension condition (LD, A, O, AB, OB)	Input condition (I/O, flag)	Command, declaration			Output (Output, flag)
		Command, declaration	Operand 1	Operand 2	
E	N, Cnd	Cmnd	Operand1	Operand2	Pst
Optional	Optional	WRIT	Channel No..	Column No.	CC (*1)

Applicable models
All models

[Function] Write the character string in the column specified in operand 2 to the channel specified in operand 1.

The operation will end when the character specified by a SCHA command is written.

Either a local or global column can be specified.

Note 1 Channel No. 31 through 34 can be specified in operand 1 with the Ethernet.

Note 2 Be sure to design the program in such a way that the normal completion or abnormal completion of the return code will always be confirmed before moving on to the next process.

*1 Other than Channel 1 and 2 should be CP.

[Example for SEL Program

No.	E	N	Cnd	Cmnd	Operand1	Operand2	Pst	Comment
				...				
				...				
				SCHA	10			Set 10 (=LF) as the end character.
				...				
				...				
				WRIT	31	5	992	Read the character string from channel 31 to column 5 until LF is read.
				TRAN	3	99		Store the return code in variable 3.
		N	992	GOTO	17			READ failed → Proceed to error handling or retry process after closing.

[Return code of WRIT command]

The return code is stored in the local variable specified in Other parameter No. 24. The default setting is variable 99.

Return code	Contents	Remarks
0	WRIT completed successfully	Terminated in normal condition.
1	WRIT timeout	Timed out. The duration of timeout can be adjusted in the following parameters. I/O Parameter No. 127 "Network Attribute 8 (Bit 16-23)"
2	WRIT timer cancelled	The timer has been cancelled by such as TIMC Command from another program.
5	WRIT factor error	A program compulsory termination error has occurred. (This error cannot be recognized through SEL commands.)
6	WRIT task ended	There was such as a compulsory termination request of a program. (This error cannot be recognized through SEL commands.)
15	WRIT connection error	Connection from the mating device has been cut. Execute CLOS Command and then OPEN Command again.
16	WRIT other command error	A controller internal error has occurred. Execute CLOS Command and then OPEN Command again.
17	WRIT other error	
18	WRIT Job Compulsorily Terminated Error	
50~	WRIT device error	There was an Ethernet device error. Execute CLOS Command and then OPEN Command again.

[7] SCHA (Set end character)

Extension condition (LD, A, O, AB, OB)	Input condition (I/O, flag)	Command, declaration			Output (Output, flag)
		Command, declaration	Operand 1	Operand 2	
E	N, Cnd	Cmnd	Operand1	Operand2	Pst
Optional	Optional	SCHA	Character code	Prohibited	

Applicable models
All models

[Function] Set the end character to be used by a READ or WRIT command.

Any character from 0 to 255 (character code used in BASIC, etc.) can be specified.

[Example for SEL Program]

Refer to [READ and WRIT Commands].

[8] IPCN (Connected Destination IP address / Port Number Setting) * When the Ethernet is used

Extension condition (LD, A, O, AB, OB)	Input condition (I/O, flag)	Command, declaration			Output (Output, flag)
		Command, declaration	Operand 1	Operand 2	
E	N, Cnd	Cmnd	Operand1	Operand2	Pst
Optional	Optional	IPCN	Channel No..	Integer variable No.	CP

Applicable models
All models

[Function] It is a command used in the non-procedure communication in Ethernet.

The storage area for the connected destination IP address and port number in the free-for-user TCP/IP channel should be set established. The connected destination information stored in the five integer variables in a row starting from an integer variable number indicated in Operation 2 should be set as the connected destination of the free-for-user TCP/IP channel number indicated in Operation 1.

Make sure that this command is executed before OPEN Command.

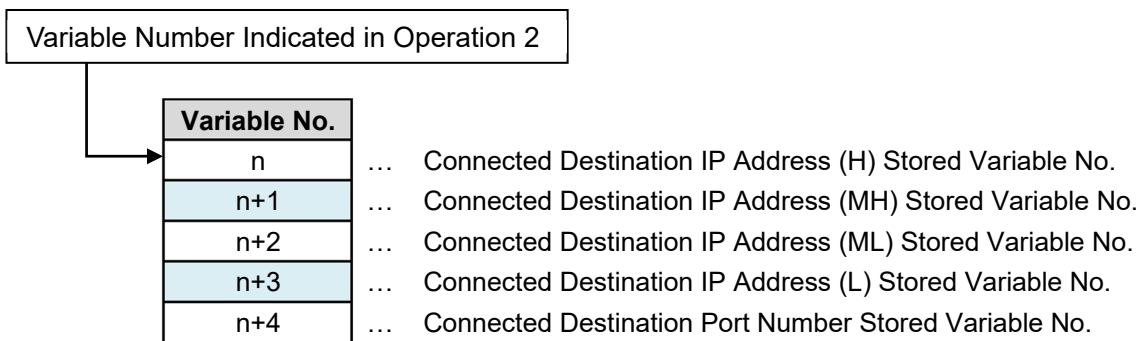

Note 1 The channel numbers available to indicate in Operation 1 in the Ethernet option should be from 31 to 34.

Note 2 If this command gets executed during open, it should be set as the command for the next open.

[Example for SEL Program]

No.	E	N	Cnd	Cmnd	Operand1	Operand2	Pst	Comment
1				LET	90	192		Connected Destination IP Address (H) = 192
2				LET	91	168		Connected Destination IP Address (MH) = 168
3				LET	92	72		Connected Destination IP Address (ML) = 72
4				IET	93	101		Connected Destination IP Address (L) = 101
5				LET	94	64514		Connected Destination Port Number = 64514
6				IPCN	31	90		Declares Channel 21 connected destination IP address / port number stored area = Local integer variables from 90 to 94.

Note In this example, IP address 192. 168. 72. 101 and port number 64514 are set as the connected destination for Free-for-User TCP/IP Channel No. 31.

[9] TIMC (Cancel timer)

Extension condition (LD, A, O, AB, OB)	Input condition (I/O, flag)	Command, declaration			Output (Output, flag)
		Command, declaration	Operand 1	Operand 2	
E	N, Cnd	Cmnd	Operand1	Operand2	Pst
Optional	Optional	TIMC	Program	Prohibited	CP

Applicable models
All models

[Function] Cancel a timer in other program running in parallel.

Note 1 Timers in TIMW, WTON, WTOF, READ, OPEN, SLVS, WRIT and GTVD commands can be cancelled. In the case of WTON, WTOF and READ commands, even if timeout is not specified it is assumed that an unlimited timer has been specified and the wait time will be cancelled.

[Example for SEL Program]

(1)

Cmnd	Operand1	Operand2
TIMC	10	

Cancel the wait time in program 10.

(2)

Cmnd	Operand1	Operand2
LET	1	10
TIMC	*1	

Assign 10 to variable 1.

Cancel the wait time in the content of variable 1 (program 10).

(3)

Program 1

Cmnd	Operand1
:	
:	
:	
TIMC	10

Program 10

Cmnd	Operand1	Operand2
:		
WTON	8	20
(Wait for input 8)		
(Wait for input 8)		

Program 10 waits for input 8 for 20s.

Cancel the wait in Program 10 and proceed to the next command.

Note The steps shown in the above example represent those executed simultaneously in different programs.

Ethernet

Chapter 7

Remote I/O (Modbus/TCP)

7.1	Setup of Communication Environment	7-2
7.2	Remote I/O Setup Procedure	7-4
7.2.1	Configuration with Modbus/TCP Only (No expansion I/O board)	7-4
7.2.2	Combined Use of Expansion I/O Board (Modbus/TCP + Expanded I/O)	7-6
7.3	Setup Procedure for Exception Status Support	7-8
7.4	Correspondence of Modbus/TCP Address and XSEL I/O	7-9
7.4.1	Little Endian Operation	7-10
7.4.2	Big Endian Operation	7-13
7.5	Installation to a Modbus/TCP System	7-16

In this chapter, explains about controls of the remote I/O using Modbus/TCP.

Modbus/TC can be used in XSEL-J/JX,XSEL-K/KE/KT/KET/KX/KETX, TT and XSEL-P/Q/PX/QX equipped with the EtherNet/IP option.



Caution

- In this manual, anything related to how to set up or how to use an EtherNet/IP module as a remote I/O is not explained.

When EtherNet/IP is to be used as a remote I/O, refer to [EtherNet/IP Instruction Manual Program Controller Edition (Control Number: ME0308)].

7.1 Setup of Communication Environment

The SEL controller provides IP addresses and other network-definition areas in its I/O parameters for control of Modbus/TCP operation.



Warning

- Set the necessary parameters according to the network environment before connecting to the network. Establishing a connection without setting the parameters may disable normal communication to and from other devices on the network.
-

[I/O parameters]

No.	Parameter name	Setting value	Input range	Remarks
129	Network attribute 10	1 _H	0 _H ~ FFFFFFFF _H	Ethernet operation requirement <ul style="list-style-type: none"> • Bits 0 to 3: Remote I/O <ul style="list-style-type: none"> 0: Do not use 1: Use Modbus/TCP (EXCEPTION status invalid) 2: Use Modbus/TCP (EXCEPTION^{*1} status valid) 3: Use EtherNet/IP^{*2} • Bits 4 to 7: TCP/IP message communication <ul style="list-style-type: none"> 0: Do not use, 1: Use • Bits 8 to 31: Not used
130	Own MAC address (H)	0030 _H	Reference value (HEX)	Only the lower two bytes are valid. (This parameter is not settable.)
131	Own MAC address (L)	11 _H	Reference value (HEX)	(This parameter is not settable.)
132	Own IP address (H)	192	1 ~ 255	* Setting of "0" and "127" is prohibited.
133	Own IP address (MH)	168	0 ~ 255	
134	Own IP address (ML)	0	0 ~ 255	
135	Own IP address (L)	1	1 ~ 254	* Setting of "0" and "255" is prohibited.
136	Subnet mask (H)	255	0 ~ 255	
137	Subnet mask (MH)	255	0 ~ 255	
138	Subnet mask (ML)	255	0 ~ 255	
139	Subnet mask (L)	0	0 ~ 255	
140	Default gateway (H)	0	0 ~ 255	
141	Default gateway (MH)	0	0 ~ 255	
142	Default gateway (ML)	0	0 ~ 255	
143	Default gateway (L)	0	0 ~ 255	

*1 The XSEL Ethernet option supports the function that notifies the host of an error condition (the upper two digits of the error number) of the XSEL controller using an exception code stored in Modbus/TCP.

Refer to [7.3 How to Set up Support for Exception Status] for details.

*2 The models applicable for EtherNet/IP should be XSEL-P/Q/PX/QX types (applicable version: Main Application Ver. 1.05 and later). Also, it is necessary to have an interface board applicable for EtherNet/IP in order to use EtherNet/IP.

Refer to [EtherNet/IP Instruction Manual Program Controller Edition (Control Number: ME0308)] for details when using EtherNet/IP.

* Set I/O parameter No. 129 to "1" to perform Modbus/TCP operation.

* The Modbus/TCP port number on the controller side is fixed at "502".

7.2 Remote I/O Setup Procedure

The system is configured only with the remote I/Os of Modbus/TCP, with the I/O port numbers being specified according to fixed port assignment.

7.2.1 Configuration with Modbus/TCP Only (No expansion I/O board)

The following settings are applicable when the system is configured only with the remote I/Os of Modbus/TCP and the standard I/O ports are mapped on Modbus/TCP without connections to any external devices via I/O boards.

[I/O parameters: XSEL-J/K/JX/KX]

No.	Parameter name	Setting value	Input range	Remarks
1	I/O port assignment type	0	0 ~ 20	0: Fixed assignment I/O port numbers are specified by parameters. 1: Automatic assignment (priority sequence: slot 1~)
2	Standard I/O input-port start number (I/O1)	0	-1 ~ 599	Set as 0 + "multiple of 8". * It gets inactivated when a negative value is set. 0: Assign Modbus/TCP remote DIs from No. 0.
3	Standard I/O output-port start number (I/O1)	300	-1 ~ 599	Set as 300 + "multiple of 8". * It gets inactivated when a negative value is set. 300: Assign Modbus/TCP remote DOs from No. 300.
4	Expanded I/O1 input-port start number based on fixed assignment (I/O2)	-1	-1 ~ 599	Set as 0 + "multiple of 8". (A negative value is invalid.) -1: No DI (input assignment) in Extension I/O 1
5	Expanded I/O1 output-port start number based on fixed assignment (I/O2)	-1	-1 ~ 599	Set as 300 + "multiple of 8". (A negative value is invalid.) -1: No DO (output assignment) in Extension I/O 1
6	Expanded I/O2 input-port start number based on fixed assignment (I/O3)	-1	-1 ~ 599	Set as 0 + "multiple of 8". (A negative value is invalid.) -1: No DI (input assignment) in Extension I/O 2
7	Expanded I/O2 output-port start number based on fixed assignment (I/O3)	-1	-1 ~ 599	Set as 300 + "multiple of 8". (A negative value is invalid.) -1: No DO (output assignment) in Extension I/O 2
8	Expanded I/O3 input-port start number based on fixed assignment (I/O4)	-1	-1 ~ 599	Set as 0 + "multiple of 8". (A negative value is invalid.) -1: No DI (input assignment) in Extension I/O 3
9	Expanded I/O3 output-port start number based on fixed assignment (I/O4)	-1	-1 ~ 599	Set as 300 + "multiple of 8". (A negative value is invalid.) -1: No DO (output assignment) in Extension I/O 3
10	Standard I/O error monitor (I/O1)	2	0 ~ 5	0: Do not monitor 1: Monitor 2: Monitor (Do not monitor 24V I/O power error) 3: Monitor (Monitor 24V I/O power error only)
11	Expanded I/O1 error monitor (I/O2)	0	0 ~ 5	
12	Expanded I/O2 error monitor (I/O3)	0	0 ~ 5	
13	Expanded I/O3 error monitor (I/O4)	0	0 ~ 5	
14	Number of ports using network I/F-card remote input	n	0 ~ 256	Specify the Modbus/TCP remote DI bits by a multiple of 8 ($8 \leq n \leq 256$).
15	Number of ports using network I/F-card remote output	m	0 ~ 256	Specify the Modbus/TCP remote DO bits by a multiple of 8 ($8 \leq n \leq 256$).

Note When word registers are to be used in Modbus/TCP, set the remote I/O head numbers (I/O port start numbers: I/O parameters 2 and 3) on a 16-bit boundary, and also set the remote I/O bits (numbers of ports using input/output: I/O parameters 14 and 15) as a multiple of 16.

[I/O parameters: XSEL-P/Q/PX/QX]

No.	Parameter name	Setting value	Input range	Remarks
1	I/O port assignment type	0	0 ~ 20	0: Fixed assignment I/O port numbers are specified by parameters. 1: Automatic assignment (priority sequence: slot 1~)
2	Standard I/O input-port start number based on fixed assignment (I/O1)	-1	-1 ~ 599	Set as 0 + "multiple of 8". * It gets inactivated when a negative value is set. 0: Assign Modbus/TCP remote DIs from No. 0.
3	Standard I/O output-port start number based on fixed assignment (I/O1)	-1	-1 ~ 599	Set as 300 + "multiple of 8". * It gets inactivated when a negative value is set. 300: Assign Modbus/TCP remote DOs from No. 300.
4	Expanded I/O1 input-port start number based on fixed assignment (I/O2)	-1	-1 ~ 599	Set as 0 + "multiple of 8". (A negative value is invalid.) -1: No DI (input assignment) in Extension I/O 1
5	Expanded I/O1 output-port start number based on fixed assignment (I/O2)	-1	-1 ~ 599	Set as 300 + "multiple of 8". (A negative value is invalid.) -1: No DO (output assignment) in Extension I/O 1
6	Expanded I/O2 input-port start number based on fixed assignment (I/O3)	-1	-1 ~ 599	Set as 0 + "multiple of 8". (A negative value is invalid.) -1: No DI (input assignment) in Extension I/O 2
7	Expanded I/O2 output-port start number based on fixed assignment (I/O3)	-1	-1 ~ 599	Set as 300 + "multiple of 8". (A negative value is invalid.) -1: No DO (output assignment) in Extension I/O 2
8	Expanded I/O3 input-port start number based on fixed assignment (I/O4)	-1	-1 ~ 599	Set as 0 + "multiple of 8". (A negative value is invalid.) -1: No DI (input assignment) in Extension I/O 3
9	Expanded I/O3 output-port start number based on fixed assignment (I/O4)	-1	-1 ~ 599	Set as 300 + "multiple of 8". (A negative value is invalid.) -1: No DO (output assignment) in Extension I/O 3
10	Standard I/O error monitor (I/O1)	0	0 ~ 5	0: Do not monitor 1: Monitor 2: Monitor (Do not monitor 24V I/O power error) 3: Monitor (Monitor 24V I/O power error only)
11	Expanded I/O1 error monitor (I/O2)	0	0 ~ 5	
12	Expanded I/O2 error monitor (I/O3)	0	0 ~ 5	
13	Expanded I/O3 error monitor (I/O4)	0	0 ~ 5	
14	Number of ports using network I/F-card remote input	n	0 ~ 256	Indicate the input-port number with a multiple of 8 ($8 \leq n \leq 256$).
15	Number of ports using network I/F-card remote output	m	0 ~ 256	Indicate the output-port number with a multiple of 8 ($8 \leq m \leq 256$).
16	Input port start number when network I/F module fixed assignment	0	-1 ~ 599	Set as 0 + "multiple of 8". (A negative value is invalid.)
17	Output-port start number when network I/F module fixed assignment	300	-1 ~ 599	Set as 300 + "multiple of 8". (A negative value is invalid.)
18	Network I/F module error monitor	1	0 ~ 5	0: Do not monitor 1: Monitor

Note When word registers are to be used in Modbus/TCP, set the remote I/O head numbers (I/O port start numbers: I/O parameters 2 and 3) on a 16-bit boundary, and also set the remote I/O bits (numbers of ports using input/output: I/O parameters 14 and 15) as a multiple of 16.

7.2.2 Combined Use of Expansion I/O Board (Modbus/TCP + Expanded I/O)

The following settings are applicable when the standard I/O ports are mapped on Modbus/TCP (input-port start No. 0 and output-port start No. 300), while the I/O boards are used with port assignments starting with input-port start No. 200 and output-port start No. 500.

[I/O parameters: XSEL-J/K/JX/KX]

No.	Parameter name	Setting value	Input range	Remarks
1	I/O port assignment type	0	0 ~ 20	0: Fixed assignment I/O port numbers are specified by parameters. 1: Automatic assignment (priority sequence: slot 1~)
2	Standard I/O input-port start number (I/O1)	0	-1 ~ 599	Set as 0 + "multiple of 8". * It gets inactivated when a negative value is set. 0: Assign Modbus/TCP remote DIs from No. 0.
3	Standard I/O output-port start number (I/O1)	300	-1 ~ 599	Set as 300 + "multiple of 8". * It gets inactivated when a negative value is set. 300: Assign Modbus/TCP remote DOs from No. 300.
4	Expanded I/O1 input-port start number based on fixed assignment (I/O2)	200	-1 ~ 599	Set as 0 + "multiple of 8". (A negative value is invalid.) -1: No DI (input assignment) in Extension I/O 1
5	Expanded I/O1 output-port start number based on fixed assignment (I/O2)	500	-1 ~ 599	Set as 300 + "multiple of 8". (A negative value is invalid.) -1: No DO (output assignment) in Extension I/O 1
6	Expanded I/O2 input-port start number based on fixed assignment (I/O3)	-1	-1 ~ 599	Set as 0 + "multiple of 8". (A negative value is invalid.) -1: No DI (input assignment) in Extension I/O 2
7	Expanded I/O2 output-port start number based on fixed assignment (I/O3)	-1	-1 ~ 599	Set as 300 + "multiple of 8". (A negative value is invalid.) -1: No DO (output assignment) in Extension I/O 2
8	Expanded I/O3 input-port start number based on fixed assignment (I/O4)	-1	-1 ~ 599	Set as 0 + "multiple of 8". (A negative value is invalid.) -1: No DI (input assignment) in Extension I/O 3
9	Expanded I/O3 output-port start number based on fixed assignment (I/O4)	-1	-1 ~ 599	Set as 300 + "multiple of 8". (A negative value is invalid.) -1: No DO (output assignment) in Extension I/O 3
10	Standard I/O error monitor (I/O1)	2	0 ~ 5	0: Do not monitor 1: Monitor 2: Monitor (Do not monitor 24 V I/O power error) 3: Monitor (Monitor 24 V I/O power error only)
11	Expanded I/O1 error monitor (I/O2)	1	0 ~ 5	
12	Expanded I/O2 error monitor (I/O3)	0	0 ~ 5	
13	Expanded I/O3 error monitor (I/O4)	0	0 ~ 5	
14	Number of ports using network I/F-card remote input	n	0 ~ 256	Specify the Modbus/TCP remote DI bits by a multiple of 8 ($8 \leq n \leq 256$).
15	Number of ports using network I/F-card remote output	m	0 ~ 256	Specify the Modbus/TCP remote DO bits by a multiple of 8 ($8 \leq n \leq 256$).

- (Note) 1. Establish the setting to have both the number of input points and output points at 300 or less.
- The last DI (digital input port) number should be 299 or below, while the last DO (digital output port) number should be 599 or below.
 - When word registers are to be used in Modbus/TCP, set the remote I/O head numbers (I/O parameters No. 2 and No. 3) on a 16-bit boundary. In addition, set the remote I/O bits (number of input/output points to be used: I/O parameters No. 14 and No. 15) as a multiple of 16.

[I/O parameters: XSEL-P/Q/PX/QX]

No.	Parameter name	Setting value	Input range	Remarks
1	I/O port assignment type	0	0 ~ 20	0: Fixed assignment I/O port numbers are specified by parameters. 1: Automatic assignment (priority sequence: slot 1~)
2	Standard I/O input-port start number based on fixed assignment (I/O1)	200	-1 ~ 599	Set as 0 + "multiple of 8". (A negative value is invalid.)
3	Standard I/O output-port start number based on fixed assignment (I/O1)	500	-1 ~ 599	Set as 300 + "multiple of 8". (A negative value is invalid.)
4	Expanded I/O1 input-port start number based on fixed assignment (I/O2)	-1	-1 ~ 599	Set as 0 + "multiple of 8". (A negative value is invalid.) -1: No expanded I/O1 DI
5	Expanded I/O1 output-port start number based on fixed assignment (I/O2)	-1	-1 ~ 599	Set as 300 + "multiple of 8". (A negative value is invalid.) -1: No expanded I/O1 DO
6	Expanded I/O2 input-port start number based on fixed assignment (I/O3)	-1	-1 ~ 599	Set as 0 + "multiple of 8". (A negative value is invalid.) -1: No expanded I/O2 DI
7	Expanded I/O2 output-port start number based on fixed assignment (I/O3)	-1	-1 ~ 599	Set as 300 + "multiple of 8". (A negative value is invalid.) -1: No expanded I/O2 DO
8	Expanded I/O3 input-port start number based on fixed assignment (I/O4)	-1	-1 ~ 599	Set as 0 + "multiple of 8". (A negative value is invalid.) -1: No expanded I/O3 DI
9	Expanded I/O3 output-port start number based on fixed assignment (I/O4)	-1	-1 ~ 599	Set as 300 + "multiple of 8". (A negative value is invalid.) -1: No expanded I/O3 DO
10	Standard I/O error monitor (I/O1)	1	0 ~ 5	0: Do not monitor 1: Monitor 2: Monitor (Do not monitor 24 V I/O power error) 3: Monitor (Monitor 24 V I/O power error only)
11	Expanded I/O1 error monitor (I/O2)	0	0 ~ 5	
12	Expanded I/O2 error monitor (I/O3)	0	0 ~ 5	
13	Expanded I/O3 error monitor (I/O4)	0	0 ~ 5	
14	Number of ports using network I/F-card remote input	n	0 ~ 256	Indicate the input-port number with a multiple of 8 ($8 \leq n \leq 256$).
15	Number of ports using network I/F-card remote output	m	0 ~ 256	Indicate the Output-port number with a multiple of 8 ($8 \leq n \leq 256$).
16	Input-port start number when network I/F module fixed assignment	0	-1 ~ 599	Set as 0 + "multiple of 8". (A negative value is invalid.)
17	Output-port start number when network I/F module fixed assignment	300	-1 ~ 599	Set as 300 + "multiple of 8". (A negative value is invalid.)
18	Network I/F module error monitor	1	0 ~ 5	0: Do not monitor 1: Monitor

Note When word registers are to be used in Modbus/TCP, set the remote I/O head numbers (I/O parameters No. 2 and No. 3) on a 16-bit boundary. In addition, set the remote I/O bits (number of input/output points to be used: I/O parameters No. 14 and No. 15) as a multiple of 16.

7.3 Setup Procedure for Exception Status Support

The XSEL Ethernet option supports the function that notifies the host of an error condition (the upper two digits of the error number) of the XSEL controller using an exception code stored in Modbus/TCP.

By setting I/O Parameter No. 129 “Network Attribute 10 (Bit 0-3)” to “2 (HEX)”, it is available to notify an error to the host controller via Modbus/TCP when an error has occurred in an XSEL controller.

The EXCEPTION status stores the upper two digits (one byte) of the system error number (consisting of three digits). When this EXCEPTION status is used, provide measures appropriate for the error level by referring to the [descriptions in the “Error Level Control” section of the instruction manual for the XSEL controller].



Caution

- The system error number cannot be specified from the EXCEPTION status (two digits). (This is because the error number consists of three digits.)

7.4 Correspondence of Modbus/TCP Address and XSEL I/O

Modbus/TCP can address the same object using either bit addressing or word addressing. The DI area (bit numbers from No. 0 up to No. 299 can be defined) of the XSEL controller is mapped in the word address 0x400 (1024) (coil and holding register as viewed from the PC side) under Modbus/TCP.

The DO area (bit numbers from No. 300 up to No. 599 can be defined) of the XSEL controller is mapped in the word address 0x000 (0) (input discrete and input register as viewed from the PC side) under Modbus/TCP.

Since the DI addressing in the XSEL controller and the addressing via Modbus are different, it is important to note the following two points:

- 1) The number order of one byte in the byte boundary is reversed.

(Example)

XSEL DI7 → Modbus bit address 1 (Modbus/TCP bit address 0)

DI0 → Modbus bit address 8 (Modbus/TCP bit address 7)

- 2) When register access is executed from the XSEL controller using an IN, INB, OUT or OUTB command, the upper and lower bytes will be reversed.

(Example)

Writing 0x1234 to 16 bits from XSEL DO300

→ Modbus input register 0 (Modbus/TCP bit address 0)

DI0 → Modbus bit address 8 (Modbus/TCP bit address 7)

Both the Motorola and Intel formats can be supported using an FMIO command.

(Refer in the section for [Chapter 2 Explanation of Command Language in SEL Programming Manual (ME0224)])

The FMIO command changes the endian in IN/OUT commands. Executing input or output after an FMIO command execution with the “format type set to 1” will align the byte order with Modbus/TCP. Each FMIO command is valid only with respect to the task for which the command is executed.

In the following page, explains details about how to treat this.

7.4.1 Little Endian Operation

The default endian mode of DI (digital input)/DO (digital output) operation commands of the XSEL controller is the little endian. In the little endian mode, the remote I/O field accessed via word operation with an IN, INB, OUT or OUTB command of the XSEL controller will have its upper and lower bytes reversed in relation to the XSEL data if the same field is word-accessed via Modbus/TCP.

The following examples are based on 256-bit assignments from the head DO number (= 300) in XSEL as Modbus/TCP remote I/Os.



Caution

- Remote I/Os can be defined only as consecutive numbers.
The assignable head number must satisfy: $300 + 8n$ ($31 \geq n \geq 0$).
The total number of assignable bits must satisfy: $m + n < 32$ & $32 \geq m$, where m represents the number of assigned remote I/O bytes.
-

[Modbus/TCP input areas (assignment of XSEL DO area 300 onward)]

Address	BIT7 (MSB)	6	5	4	3	2	1	0 (LSB)
XSEL DO	307	306	305	304	303	302	301	300
Modbus/TCP bit address	0	1	2	3	4	5	6	7
Modbus/TCP word address	0 Lower byte							
Modbus input status	10001	10002	10003	10004	10005	10006	10007	10008
Modbus input register	30001 Lower byte							
XSEL DO	315	314	313	312	311	310	309	308
Modbus/TCP bit address	8	9	10	11	12	13	14	15
Modbus/TCP word address	0 Upper byte							
Modbus input status	10009	10010	10011	10012	10013	10014	10015	10016
Modbus input register	30001 Upper byte							
:								
:								
XSEL DO	547	546	545	544	543	542	541	540
Modbus/TCP bit address	240	241	242	243	244	245	246	247
Modbus/TCP word address	15 Lower byte							
Modbus input status	10248	10249	10250	10251	10252	10253	10254	10255
Modbus input register	30016 Lower byte							
XSEL DO	555	554	553	552	551	550	549	548
Modbus/TCP word address	15 Upper byte							
Modbus/TCP bit address	248	249	250	251	252	253	254	255
Modbus input status	10249	10250	10251	10252	10253	10254	10255	10256
Modbus input register	30016 Upper byte							
	Cannot be used							

Input status: input discretetes single bit, provided by an I/O system, read-only
Output coil: output discretetes single bit, alterable by an application program, read-write
Input register: input registers 16-bit quantity, provided by an I/O system, read-only
Output register: output registers 16-bit quantity, alterable by an application program, read-write

The output areas are described on the next page.

7.4 Correspondence of Modbus/TCP Address and XSEL I/O

[Modbus/TCP output areas (assignment of XSEL DI area 300 onward), FMIO = 0]

Address	BIT7 (MSB)	6	5	4	3	2	1	0 (LSB)
XSEL DI	7	6	5	4	3	2	1	0
Modbus/TCP bit address	16384	16385	16386	16387	16388	16389	16390	16391
Modbus/TCP word address	1024 Lower byte							
Modbus output coil	1	2	3	4	5	6	7	8
Modbus hold register	40001 Lower byte							
XSEL DI	15	14	13	12	11	10	9	8
Modbus/TCP bit address	16392	16393	16394	16395	16396	16397	16398	16399
Modbus/TCP word address	1024 Upper byte							
Modbus output coil	9	10	11	12	13	14	15	16
Modbus hold register	40001 Upper byte							
:								
:								
XSEL DI	247	246	245	244	243	242	241	240
Modbus/TCP bit address	16624	16625	16626	16627	16628	16629	16630	16631
Modbus/TCP word address	1039 Lower byte							
Modbus output coil	241	242	243	244	245	246	247	248
Modbus hold register	40016 Lower byte							
XSEL DI	255	254	253	252	251	250	249	248
Modbus/TCP bit address	16632	16633	16634	16635	16636	16637	16638	16639
Modbus/TCP word address	1039 Upper byte							
Modbus output coil	249	250	251	252	253	254	255	256
Modbus hold register	40016 Upper byte							
	Cannot be used							

7.4.2 Big Endian Operation

To align the word handling between Modbus/TCP and the XSEL controller, the I/O operation mode must be set to the big endian with an FMIO command before executing a DI (digital input)/DO (digital output) operation command in any XSEL task.

With this setting the remote I/O field accessed via word operation with an IN, INB, OUT or OUTB command of the XSEL controller can be handled as the same data when the same field is word-accessed via Modbus/TCP.

The following examples are based on 256-bit assignments from the head DO number (= 300) in XSEL as Modbus/TCP remote I/Os.

The only difference from the examples shown in [6.4.1 Little Endian Operation], is the byte order of the word registers.



Caution

- Remote I/Os can be defined only as consecutive numbers.
The assignable head number must satisfy: $300 + 8n$ ($31 \geq n \geq 0$).
The total number of assignable bits must satisfy: $m + n < 32$ & $32 \geq m$, where m represents the number of assigned remote I/O bytes.

7.4 Correspondence of Modbus/TCP Address and XSEL I/O

[Modbus/TCP input areas (assignment of XSEL DO area 300 onward)]

Address	BIT7 (MSB)	6	5	4	3	2	1	0 (LSB)
XSEL DO	307	306	305	304	303	302	301	300
Modbus/TCP bit address	0	1	2	3	4	5	6	7
Modbus/TCP word address	0 Upper byte							
Modbus input status	10001	10002	10003	10004	10005	10006	10007	10008
Modbus input register	30001 Upper byte							
XSEL DO	315	314	313	312	311	310	309	308
Modbus/TCP bit address	8	9	10	11	12	13	14	15
Modbus/TCP word address	0 Lower byte							
Modbus input status	10009	10010	10011	10012	10013	10014	10015	10016
Modbus input register	30001 Lower byte							
:								
:								
XSEL DO	547	546	545	544	543	542	541	540
Modbus/TCP bit address	240	241	242	243	244	245	246	247
Modbus/TCP word address	15 Upper byte							
Modbus input status	10248	10249	10250	10251	10252	10253	10254	10255
Modbus input register	30016 Upper byte							
XSEL DO	555	554	553	552	551	550	549	548
Modbus/TCP word address	15 Lower byte							
Modbus/TCP bit address	248	249	250	251	252	253	254	255
Modbus input status	10249	10250	10251	10252	10253	10254	10255	10256
Modbus input register	30016 Lower byte							
	Cannot be used							

Input status: input discretetes single bit, provided by an I/O system, read-only
 Output coil: output discretetes single bit, alterable by an application program, read-write
 Input register: input registers 16-bit quantity, provided by an I/O system, read-only
 Output register: output registers 16-bit quantity, alterable by an application program, read-write

The output areas are described on the next page.

[Modbus/TCP output areas (assignment of XSEL DI area 300 onward), FMIO = 0]

Address	BIT7 (MSB)	6	5	4	3	2	1	0 (LSB)
XSEL DI	7	6	5	4	3	2	1	0
Modbus/TCP bit address	16384	16385	16386	16387	16388	16389	16390	16391
Modbus/TCP word address	1024 Upper byte							
Modbus output coil	1	2	3	4	5	6	7	8
Modbus hold register	40001 Upper byte							
XSEL DI	15	14	13	14	15	10	9	8
Modbus/TCP bit address	16392	16393	16394	16395	16396	16397	16398	16399
Modbus/TCP word address	1024 Lower byte							
Modbus output coil	9	10	11	12	13	14	15	16
Modbus hold register	40001 Lower byte							
:								
:								
XSEL DI	247	246	245	244	243	242	241	240
Modbus/TCP bit address	16624	16625	16626	16627	16628	16629	16630	16631
Modbus/TCP word address	1039 Upper byte							
Modbus output coil	241	242	243	244	245	246	247	248
Modbus hold register	40016 Upper byte							
XSEL DI	255	254	253	252	251	250	249	248
Modbus/TCP bit address	16632	16633	16634	16635	16636	16637	16638	16639
Modbus/TCP word address	1039 Lower byte							
Modbus output coil	249	250	251	252	253	254	255	256
Modbus hold register	40016 Lower byte							
	Cannot be used							

7.5 Installation to a Modbus/TCP System

No special tools are required for operation of the XSEL controller via Modbus/TCP on Ethernet. Simply set the controller parameters, connect the Ethernet cable and turn on the power. The Modbus/TCP server in the controller will be started, enabling remote I/O control.

The Ethernet port number of Modbus/TCP is fixed at “502”.

Modbus/TCP connection is established by specifying IP address port 502 for the XSEL controller via an OPC (OLE for process control) server or other Modbus/TCP software.

To check whether the network setup of the controller is correct, use a “ping” command (the command for checking the status of communication on the IP level of TCP/IP using a command prompt) or similar command. (Refer to [4.5 Check Ping Response from PC] for details.)

Ethernet

Chapter 8

Appendix

8.1	List of Related Alarms	8-1
8.2	ASCII Code List	8-5

8.1 List of Related Alarms

- Secret level error

No.	Error name	Detail / Countermeasure
80F (104)	Ethernet control status 1	<p>[Detail & Cause] Ethernet control information (for manufacturer analysis). (This is not an error.)</p> <p>[Countermeasure] Switch the communication channel open and close for several times and if TCP/IP message communication cannot be established, report the content in the error list and the symptoms to IAI.</p>
810 (104)	Ethernet control status 2	<p>[Detail & Cause] Ethernet control information (for manufacturer analysis). (This is not an error.)</p> <ol style="list-style-type: none"> 1) The connection request output from SEL controller in TCP/IP message communication was rejected by the mating device. Or, the mating device is not activated. 2) TCP/IP message communication was shut down by the mating device. 3) An overflow occurred in the TCP/IP message communication receiving data buffer. <p>[Countermeasure] 1) 2) Confirm that the IP address and the port number on the mating device are correct. Also, check the condition of the mating device. 3) Confirm that the delimiter is being sent from the mating device. Also, check that the data to be sent does not exceed the receiving data buffer size of the SEL controller.</p>

- Message level error

No.	Error name	Detail / Countermeasure
A6C (234)	PC/TP operation refusal error during AUTO mode	<p>[Detail & Cause] Operation of an actuator from a teaching tool (servo on or movement command) has been conducted during AUTO Mode.</p> <p>[Countermeasure] Set the AUTO/MANU toggle switch on the controller front panel to MANU side before operation.</p>

Note The codes in brackets () are alarm codes for RSEL.

● Operation-cancellation level error

No.	Error name	Detail / Countermeasure
B00 (41B)	SCHA setting error	<p>[Detail & Cause] The input in Operant 1 in SCHA Command is a value out of the range from 0 to 255 in ASCII Code description.</p> <p>[Countermeasure] Check the value input to Operant1 in SCHA Command in ASCII Code List (refer to [8.2 ASCII Code List]) and change it to a value in the range from 0 to 255.</p> <p>[Complement] 1) The SCHA Command sets the termination character used in READ and WRIT Commands. 2) A value (character) can indicate in the range from 0 to 255 (ASCII Code description used in BASIC and so on. Although a value (character) is a free input as long as it is in the range, what should be usually used as the end character is 10 (LF).</p>
B12 (485)	SEL command return dome storage variable number error	<p>[Detail & Cause] A value out of the range is set in Other Parameter No. 24 "SEL Communication Command Return Code Storage Local Variable Number". (Occurred while OPEN Command, READ Command or WRITE Command has been executed)</p> <p>[Countermeasure] Set a value in a range from 1 to 99 or from 1001 to 1099 in Other Parameter No. 24.</p>
B1B (473)	Ethernet unclosed socket open error	<p>[Detail & Cause] During Ethernet communication, OPEN Command was executed again before closing a socket with CLOS Command in SEL program.</p> <p>[Countermeasure] Check the program that had the error and change it to close a channel with CLOS Command that opened with OPEN Command. * Make it not to have CLOSE Command executed by GOTO Command, conditional branching or input conditions.</p>
B1C ^{**}	Ethernet other task in use error	It was attempted to open a channel again that has already been open in another task.
B1D ^{**}	Ethernet non-open error	It was attempted to use a channel that is not open in its task.
B1E ^{**}	Ethernet duplicated WRIT execution error	WRIT Command attempted to be executed to the same channel in several tasks, or WRIT Command was executed again without executing CLOS Command → OPEN Command after WRIT failure (such as communication error).
B1F ^{**}	Ethernet job busy error	A new process attempted to start as the Ethernet mailbox control job was busy.

No.	Error name	Detail / Countermeasure
B20 (474)	Ethernet uninitialized device use error	<p>[Detail & Cause]</p> <ol style="list-style-type: none"> 1) The IP address setting in the Ethernet communication does not match with that in the mating device. Or, it is set to an IP address that does not exist. 2) The port number setting in the Ethernet communication does not match with that in the mating device. Or, it is set to a port number that does not exist. 3) The Ethernet communication is disabled in the parameter setting. <p>[Countermeasure]</p> <ol style="list-style-type: none"> 1) Set the following parameters or IP address in IPCN Command in the range from 0 to 255. Also, set a value other than 0, 127 or 255 in the 1st digit and other than 0 or 255 in the 4th digit. <p>The Ethernet system tries to be used while the initialization of the Ethernet devices has not been completed. Check I/O parameters such as No. 123 to 159, 14, 15, and so on depending on the purpose of use.</p>
B21 (474)	Ethernet IP address error	<p>An error will generate under the following conditions during normal use. When IP address (H) (first octet) through IP address (L) (fourth octet) are given as IP_H, IP_MH, IP_ML and IP_L, the error conditions are described as follows: IP_H ≤ 0 or IP_H = 127 or IP_H > 255 or IP_MH < 0 or IP_MH > 255 or IP_ML < 0 or IP_ML > 255 or IP_L ≤ 0 or IP_L ≥ 255 Check I/O parameters No. 132 to 135, 149 to 152, 154 to 157 or the integer variable connected IP address indicated in IPCN command.</p>
B22 (474)	Ethernet port number error	<p>An error will generate if own port number < 1025, or own port number > 65535, or own port number duplication, or connection-destination port number for client ≤ 0, or connection-destination port number for client > 65535, or connection-destination port number for server < 0, or connection-destination port number for server > 65535 is satisfied. Check I/O parameter Nos. 144 to 148, 153, 158, and 159, the port number of connection destination specified by an IPCN command in an integer variable, or the like.</p>
B26**1	Ethernet communication mode error	<p>It is a communication mode error. It could be considered that;</p> <ul style="list-style-type: none"> • The vision system operation command (SLVS) was issued to a channel in use for communication (OPEN, CLOS, READ or WRIT). • The communication command (OPEN, CLOS, READ or WRIT) was issued to a channel in use for the vision system I/F feature. <p>The communication command (OPEN, CLOS, READ, WRIT, etc.) and the vision system operation command (SLVS, etc.) cannot be issued at the same time to one channel.</p>

8.1 List of Related Alarms

No.	Error name	Detail / Countermeasure
C3A (41A)	User-open communication channel number error	<p>[Detail & Cause] During Ethernet communication, OPEN Command was executed again before closing a socket with CLOS Command in SEL program.</p> <p>[Countermeasure] Check the program that had the error and change it to close a channel with CLOS Command that opened with OPEN Command. * Make it not to have CLOSE Command executed by GOTO Command, conditional branching or input conditions.</p>
C4B (43D)	Delimiter non-definition error	<p>[Detail & Cause] An end character is not defined.</p> <p>[Countermeasure] Set the end character with the SCHA instruction before the OPEN instruction.</p>

*1 It should not occur in XSEL-RA/SA/RAX/SAX/RAXD/SAXD or RSEL.

Note The codes in brackets () are alarm codes for RSEL.

● Cold-start level error

No.	Error name	Detail / Countermeasure
D4C (617)	Ethernet parameter error	<p>[Detail & Cause] There is an error in the parameter setting in the Ethernet IP address or port number.</p> <ul style="list-style-type: none"> • Default root (1st Octet 0), loop back address (1st Octet 127) indicated in IP address • Self port number duplicated or connected port number in inappropriate number <p>[Countermeasure] Check values in I/O Parameter No. 144 to 164 and correct values set in the parameters. Make correction in I/O Parameters from No. 172 to 175 for XSEL-RA/SA/RAX/SAX/RAXD/SAXD and RSEL.</p>
D75 (60D)	Fieldbus master parameter error (Fieldbus parameter error)	<p>[Detail & Cause] The parameters related to the fieldbus do not match with the specification of the controller, or a value is out of the range.</p> <ol style="list-style-type: none"> 1) I/O Parameter No. 255 "I/O Control" does not match with the field module type actually equipped. 2) I/O Parameter No. 226 "I/O1 Fieldbus Node Address" exceeds the setting range. 3) I/O Parameter No. 227 "I/O1 Fieldbus Baud Rate" exceeds the setting available range. 4) There is an error in the setting in I/O Parameters from 132 to 135 (set IP address on controller side). 5) Operation error due to noise. <p>[Countermeasure] 1) There is a concern that a wrong parameter (of another controller) has been transferred. Transfer the backup data or initialize the parameters. 2) Use it within the range of network specifications. 3) Establish the setting in the ranges of the network specifications. 4) Establish the setting within the range from 0 to 255. * Communication cannot be established if the IP address is set the same as PLC or another device. Make sure to set another number. 5) Cut the power off to the peripheral devices, activate only the controllers and actuators of IAI to check if this alarm would occur again. There may be influence of noise from a peripheral device concerned if it does not occur. Reconsider the countermeasure for noise (grounding, static electricity shield of cables, etc.) on the peripheral devices.</p>

8.2 ASCII Code List

Here shows the list of ASCII codes.

Upper 3 bits→ ↓Lower 4 bits	0	1	2	3	4	5	6	7
0	NUL	DLE	SP ^(Note1)	0	@	P	`	p
1	SOH	DC1	!	1	A	Q	a	q
2	STX	DC2	“	2	B	R	b	r
3	ETX	DC3	#	3	C	S	c	s
4	EOT	DC4	\$	4	D	T	d	t
5	ENQ	NAK	%	5	E	U	e	u
6	ACK	SYN	&	6	F	V	f	v
7	BEL	ETB	‘	7	G	W	g	w
8	BS	CAN	(8	H	X	h	x
9	HT	EM)	9	I	Y	i	y
A	LF	SUB	*	:	J	Z	j	z
B	VT	ESC	+	;	K	[k	{
C	FF	FS	,	<	L	\	l	
D	CR	GS	–	=	M]	m	}
E	SO	RS	.	>	N	^	n	~
F	SI	US	/	?	O	_	o	DEL

Note 1 SP means “Space (half-sized space)”.

Note Shown below is detail of control characters.

Control character	Meaning	Control character	Meaning	Control character	Meaning
NUL	Null character	DLE	Data link escape	DEL	Delete
SOH	Start header	DC1	Device control 1		
STX	Start text	DC2	Device control 2		
ETX	End text	DC3	Device control 3		
EOT	End transfer	DC4	Device control 4		
ENQ	Inquiry	NAK	Receiving failed		
ACK	Receiving Succeeded	SYN	Synchronizing		
BEL	Warning	ETB	End transfer block		
BS	Move backward	CAN	Undo		
HT	Horizontal tab	EM	End media		
LF	Begin a new line	SUB	Substitute		
VT	Vertical tab	ESC	Escape		
FF	Begin a new page	FS	Split form		
CR	Recover	GS	Split group		
SO	Shift out	RS	Split record		
SI	Shift in	US	Split unit		

Revision History

Revision date	Description of Revision
2017.02	Fourth Edition <ul style="list-style-type: none"> • Statements added for contents related to Ethernet equipped in standard to XSEL-RA/SA/RAX/SAX/ RAXD/SAXD controllers • Statements added for contents related to PC software (PC software version V13.0.0.0 and later) become available for connection to both server and client
2020.11	Fifth edition <ul style="list-style-type: none"> • Statements added regarding Ethernet of RSEL (SEL Unit), MSEL, ASEL, PSEL, SSEL and TTA
2023.07	Sixth edition <ul style="list-style-type: none"> • Full-Scale Revision • XSEL-P/Q/PX/QX deleted from this manual
2024.10	Seventh edition <ul style="list-style-type: none"> • XSEL2 controller added • 2.1 XSEL standard Ethernet ports added, later sections pulled down • 3.2 10//100/1000BASE-T added in pin assignment for Ethernet connector



IAI Corporation

Head Office: 1210 Ihara Shimizu-KU Shizuoka City Shizuoka 424-0114, Japan
TEL +81-54-364-5105 FAX +81-54-364-2589
website: www.iai-robot.co.jp/

IAI America, Inc.

Head Office: 2690 W. 237th Street, Torrance, CA 90505
TEL +1-310-891-6015 FAX +1-310-891-0815
Chicago Office: 110 East State Parkway, Schaumburg, IL 60173
TEL +1-847-908-1400 FAX +1-847-908-1399
Atlanta Office: 1220 Kennestone Circle, Suite 108, Marietta, GA 30066
TEL +1-678-354-9470 FAX +1-678-354-9471
website: www.intelligentactuator.com

Technical Support available in Europe

IAI Industrieroboter GmbH

Ober der Röth 4, D-65824 Schwalbach am Taunus, Germany
TEL +49(0)6196-88950 FAX +49(0)6196-889524
website: www.iai-automation.com

Technical Support available in Great Britain



Duttons Way, Shadsworth Business Park, Blackburn, Lancashire, BB1 2QR, United Kingdom
TEL +44(0)1254-685900
website: www.lcautomation.com

IAI (Shanghai) Co., Ltd.

SHANGHAI JIAHUA BUSINESS CENTER A8-303, 808, Hongqiao Rd. Shanghai 200030, China
TEL +86-21-6448-4753 FAX +86-21-6448-3992
website: www.iai-robot.com

IAI Robot (Thailand) Co., Ltd.

825 PhairojKijja Tower 7th Floor, Debaratana RD., Bangna-Nuea, Bangna, Bangkok 10260, Thailand
TEL +66-2-361-4458 FAX +66-2-361-4456
website: www.iai-robot.co.th