

# PROFINET IO

---

Instruction Manual, First Edition

MSEL



## Please Read Before Use

Thank you for purchasing our product.

This Instruction Manual describes all necessary information items to operate this product safely such as the operation procedure, structure and maintenance procedure.

To ensure the safe operation of this product, please read and fully understand this manual. The enclosed DVD in this product package includes the Instruction Manual for this product. For the operation of this product, print out the necessary sections in the Instruction Manual or display them using the personal computer.

After reading through this manual, keep this Instruction Manual at hand so that the operator of this product can read it whenever necessary.

### [Important]

- This Instruction Manual is original.
- The product cannot be operated in any way unless expressly specified in this Instruction Manual. IAI shall assume no responsibility for the outcome of any operation not specified herein.
- Information contained in this Instruction Manual is subject to change without notice for the purpose of product improvement.
- If you have any question or comment regarding the content of this manual, please contact the IAI sales office near you.
- Using or copying all or part of this Instruction Manual without permission is prohibited.
- The company names, names of products and trademarks of each company shown in the sentences are registered trademarks.
- PROFINET is a trademark used under the license of PROFIBUS Association.



## Table of Contents

Safety Guide .....	1
1. Overview .....	9
2. Specifications .....	10
3. MSEL .....	11
3.1 Operation Modes and Functions .....	11
3.2 Model Numbers .....	12
3.3 PROFINET IO Interface .....	12
3.3.1 Names of the Parts .....	12
3.3.2 Monitor LED Indications .....	13
3.4 Wiring Example .....	14
3.4.1 Connection Diagram (Example) .....	14
3.4.2 Connector Pin Layout .....	14
3.5 Setting .....	15
3.5.1 Parameter Setting .....	15
3.5.2 Example for Parameter Settings .....	17
3.6 I/O Ports of MSEL .....	19
3.7 I/O Port and Data Reading and Writing .....	21
3.8 Caution .....	23
4. Appendix .....	24
4.1 Troubleshooting .....	25
4.2 List of PROFINET-IO Related Parameters .....	26
4.3 Network Setting File .....	27
Change History .....	28



## Safety Guide

“Safety Guide” has been written to use the machine safely and so prevent personal injury or property damage beforehand. Make sure to read it before the operation of this product.

### Safety Precautions for Our Products

The common safety precautions for the use of any of our robots in each operation.

No.	Operation Description	Description
1	Model Selection	<ul style="list-style-type: none"><li>● This product has not been planned and designed for the application where high level of safety is required, so the guarantee of the protection of human life is impossible. Accordingly, do not use it in any of the following applications.<ol style="list-style-type: none"><li>1) Medical equipment used to maintain, control or otherwise affect human life or physical health.</li><li>2) Mechanisms and machinery designed for the purpose of moving or transporting people (For vehicle, railway facility or air navigation facility)</li><li>3) Important safety parts of machinery (Safety device, etc.)</li></ol></li><li>● Do not use the product outside the specifications. Failure to do so may considerably shorten the life of the product.</li><li>● Do not use it in any of the following environments.<ol style="list-style-type: none"><li>1) Location where there is any inflammable gas, inflammable object or explosive</li><li>2) Place with potential exposure to radiation</li><li>3) Location with the ambient temperature or relative humidity exceeding the specification range</li><li>4) Location where radiant heat is added from direct sunlight or other large heat source</li><li>5) Location where condensation occurs due to abrupt temperature changes</li><li>6) Location where there is any corrosive gas (sulfuric acid or hydrochloric acid)</li><li>7) Location exposed to significant amount of dust, salt or iron powder</li><li>8) Location subject to direct vibration or impact</li></ol></li><li>● For an actuator used in vertical orientation, select a model which is equipped with a brake. If selecting a model with no brake, the moving part may drop when the power is turned OFF and may cause an accident such as an injury or damage on the work piece.</li></ul>

No.	Operation Description	Description
2	Transportation	<ul style="list-style-type: none"> <li>● When carrying a heavy object, do the work with two or more persons or utilize equipment such as crane.</li> <li>● When the work is carried out with 2 or more persons, make it clear who is to be the leader and who to be the follower(s) and communicate well with each other to ensure the safety of the workers.</li> <li>● When in transportation, consider well about the positions to hold, weight and weight balance and pay special attention to the carried object so it would not get hit or dropped.</li> <li>● Transport it using an appropriate transportation measure. The actuators available for transportation with a crane have eyebolts attached or there are tapped holes to attach bolts. Follow the instructions in the instruction manual for each model.</li> <li>● Do not step or sit on the package.</li> <li>● Do not put any heavy thing that can deform the package, on it.</li> <li>● When using a crane capable of 1t or more of weight, have an operator who has qualifications for crane operation and sling work.</li> <li>● When using a crane or equivalent equipments, make sure not to hang a load that weighs more than the equipment's capability limit.</li> <li>● Use a hook that is suitable for the load. Consider the safety factor of the hook in such factors as shear strength.</li> <li>● Do not get on the load that is hung on a crane.</li> <li>● Do not leave a load hung up with a crane.</li> <li>● Do not stand under the load that is hung up with a crane.</li> </ul>
3	Storage and Preservation	<ul style="list-style-type: none"> <li>● The storage and preservation environment conforms to the installation environment. However, especially give consideration to the prevention of condensation.</li> <li>● Store the products with a consideration not to fall them over or drop due to an act of God such as earthquake.</li> </ul>
4	Installation and Start	<p>(1) Installation of Robot Main Body and Controller, etc.</p> <ul style="list-style-type: none"> <li>● Make sure to securely hold and fix the product (including the work part). A fall, drop or abnormal motion of the product may cause a damage or injury. Also, be equipped for a fall-over or drop due to an act of God such as earthquake.</li> <li>● Do not get on or put anything on the product. Failure to do so may cause an accidental fall, injury or damage to the product due to a drop of anything, malfunction of the product, performance degradation, or shortening of its life.</li> <li>● When using the product in any of the places specified below, provide a sufficient shield.             <ol style="list-style-type: none"> <li>1) Location where electric noise is generated</li> <li>2) Location where high electrical or magnetic field is present</li> <li>3) Location with the mains or power lines passing nearby</li> <li>4) Location where the product may come in contact with water, oil or chemical droplets</li> </ol> </li> </ul>

No.	Operation Description	Description
4	Installation and Start	<p>(2) Cable Wiring</p> <ul style="list-style-type: none"><li>● Use our company's genuine cables for connecting between the actuator and controller, and for the teaching tool.</li><li>● Do not scratch on the cable. Do not bend it forcibly. Do not pull it. Do not coil it around. Do not insert it. Do not put any heavy thing on it. Failure to do so may cause a fire, electric shock or malfunction due to leakage or continuity error.</li><li>● Perform the wiring for the product, after turning OFF the power to the unit, so that there is no wiring error.</li><li>● When the direct current power (+24V) is connected, take the great care of the directions of positive and negative poles. If the connection direction is not correct, it might cause a fire, product breakdown or malfunction.</li><li>● Connect the cable connector securely so that there is no disconnection or looseness. Failure to do so may cause a fire, electric shock or malfunction of the product.</li><li>● Never cut and/or reconnect the cables supplied with the product for the purpose of extending or shortening the cable length. Failure to do so may cause the product to malfunction or cause fire.</li></ul> <p>(3) Grounding</p> <ul style="list-style-type: none"><li>● The grounding operation should be performed to prevent an electric shock or electrostatic charge, enhance the noise-resistance ability and control the unnecessary electromagnetic radiation.</li><li>● For the ground terminal on the AC power cable of the controller and the grounding plate in the control panel, make sure to use a twisted pair cable with wire thickness 0.5mm<sup>2</sup> (AWG20 or equivalent) or more for grounding work. For security grounding, it is necessary to select an appropriate wire thickness suitable for the load. Perform wiring that satisfies the specifications (electrical equipment technical standards).</li><li>● Perform Class D Grounding (former Class 3 Grounding with ground resistance 100Ω or below).</li></ul>





No.	Operation Description	Description
4	Installation and Start	<p>(4) Safety Measures</p> <ul style="list-style-type: none"> <li>● When the work is carried out with 2 or more persons, make it clear who is to be the leader and who to be the follower(s) and communicate well with each other to ensure the safety of the workers.</li> <li>● When the product is under operation or in the ready mode, take the safety measures (such as the installation of safety and protection fence) so that nobody can enter the area within the robot's movable range. When the robot under operation is touched, it may result in death or serious injury.</li> <li>● Make sure to install the emergency stop circuit so that the unit can be stopped immediately in an emergency during the unit operation.</li> <li>● Take the safety measure not to start up the unit only with the power turning ON. Failure to do so may start up the machine suddenly and cause an injury or damage to the product.</li> <li>● Take the safety measure not to start up the machine only with the emergency stop cancellation or recovery after the power failure. Failure to do so may result in an electric shock or injury due to unexpected power input.</li> <li>● When the installation or adjustment operation is to be performed, give clear warnings such as "Under Operation; Do not turn ON the power!" etc. Sudden power input may cause an electric shock or injury.</li> <li>● Take the measure so that the work part is not dropped in power failure or emergency stop.</li> <li>● Wear protection gloves, goggle or safety shoes, as necessary, to secure safety.</li> <li>● Do not insert a finger or object in the openings in the product. Failure to do so may cause an injury, electric shock, damage to the product or fire.</li> <li>● When releasing the brake on a vertically oriented actuator, exercise precaution not to pinch your hand or damage the work parts with the actuator dropped by gravity.</li> </ul>
5	Teaching	<ul style="list-style-type: none"> <li>● When the work is carried out with 2 or more persons, make it clear who is to be the leader and who to be the follower(s) and communicate well with each other to ensure the safety of the workers.</li> <li>● Perform the teaching operation from outside the safety protection fence, if possible. In the case that the operation is to be performed unavoidably inside the safety protection fence, prepare the "Stipulations for the Operation" and make sure that all the workers acknowledge and understand them well.</li> <li>● When the operation is to be performed inside the safety protection fence, the worker should have an emergency stop switch at hand with him so that the unit can be stopped any time in an emergency.</li> <li>● When the operation is to be performed inside the safety protection fence, in addition to the workers, arrange a watchman so that the machine can be stopped any time in an emergency. Also, keep watch on the operation so that any third person can not operate the switches carelessly.</li> <li>● Place a sign "Under Operation" at the position easy to see.</li> <li>● When releasing the brake on a vertically oriented actuator, exercise precaution not to pinch your hand or damage the work parts with the actuator dropped by gravity.</li> </ul> <p>* Safety protection Fence : In the case that there is no safety protection fence, the movable range should be indicated.</p>

No.	Operation Description	Description
6	Trial Operation	<ul style="list-style-type: none"><li>• When the work is carried out with 2 or more persons, make it clear who is to be the leader and who to be the follower(s) and communicate well with each other to ensure the safety of the workers.</li><li>• After the teaching or programming operation, perform the check operation one step by one step and then shift to the automatic operation.</li><li>• When the check operation is to be performed inside the safety protection fence, perform the check operation using the previously specified work procedure like the teaching operation.</li><li>• Make sure to perform the programmed operation check at the safety speed. Failure to do so may result in an accident due to unexpected motion caused by a program error, etc.</li><li>• Do not touch the terminal block or any of the various setting switches in the power ON mode. Failure to do so may result in an electric shock or malfunction.</li></ul>
7	Automatic Operation	<ul style="list-style-type: none"><li>• Check before starting the automatic operation or rebooting after operation stop that there is nobody in the safety protection fence.</li><li>• Before starting automatic operation, make sure that all peripheral equipment is in an automatic-operation-ready state and there is no alarm indication.</li><li>• Make sure to operate automatic operation start from outside of the safety protection fence.</li><li>• In the case that there is any abnormal heating, smoke, offensive smell, or abnormal noise in the product, immediately stop the machine and turn OFF the power switch. Failure to do so may result in a fire or damage to the product.</li><li>• When a power failure occurs, turn OFF the power switch. Failure to do so may cause an injury or damage to the product, due to a sudden motion of the product in the recovery operation from the power failure.</li></ul>

No.	Operation Description	Description
8	Maintenance and Inspection	<ul style="list-style-type: none"> <li>● When the work is carried out with 2 or more persons, make it clear who is to be the leader and who to be the follower(s) and communicate well with each other to ensure the safety of the workers.</li> <li>● Perform the work out of the safety protection fence, if possible. In the case that the operation is to be performed unavoidably inside the safety protection fence, prepare the “Stipulations for the Operation” and make sure that all the workers acknowledge and understand them well.</li> <li>● When the work is to be performed inside the safety protection fence, basically turn OFF the power switch.</li> <li>● When the operation is to be performed inside the safety protection fence, the worker should have an emergency stop switch at hand with him so that the unit can be stopped any time in an emergency.</li> <li>● When the operation is to be performed inside the safety protection fence, in addition to the workers, arrange a watchman so that the machine can be stopped any time in an emergency. Also, keep watch on the operation so that any third person can not operate the switches carelessly.</li> <li>● Place a sign “Under Operation” at the position easy to see.</li> <li>● For the grease for the guide or ball screw, use appropriate grease according to the Instruction Manual for each model.</li> <li>● Do not perform the dielectric strength test. Failure to do so may result in a damage to the product.</li> <li>● When releasing the brake on a vertically oriented actuator, exercise precaution not to pinch your hand or damage the work parts with the actuator dropped by gravity.</li> <li>● The slider or rod may get misaligned OFF the stop position if the servo is turned OFF. Be careful not to get injured or damaged due to an unnecessary operation.</li> <li>● Pay attention not to lose the cover or untightened screws, and make sure to put the product back to the original condition after maintenance and inspection works. Use in incomplete condition may cause damage to the product or an injury.</li> </ul> <p>* Safety protection Fence : In the case that there is no safety protection fence, the movable range should be indicated.</p>
9	Modification and Dismantle	<ul style="list-style-type: none"> <li>● Do not modify, disassemble, assemble or use of maintenance parts not specified based at your own discretion.</li> </ul>
10	Disposal	<ul style="list-style-type: none"> <li>● When the product becomes no longer usable or necessary, dispose of it properly as an industrial waste.</li> <li>● When removing the actuator for disposal, pay attention to drop of components when detaching screws.</li> <li>● Do not put the product in a fire when disposing of it. The product may burst or generate toxic gases.</li> </ul>
11	Other	<ul style="list-style-type: none"> <li>● Do not come close to the product or the harnesses if you are a person who requires a support of medical devices such as a pacemaker. Doing so may affect the performance of your medical device.</li> <li>● See Overseas Specifications Compliance Manual to check whether complies if necessary.</li> <li>● For the handling of actuators and controllers, follow the dedicated instruction manual of each unit to ensure the safety.</li> </ul>

## Alert Indication

The safety precautions are divided into “Danger”, “Warning”, “Caution” and “Notice” according to the warning level, as follows, and described in the Instruction Manual for each model.

Level	Degree of Danger and Damage	Symbol
Danger	This indicates an imminently hazardous situation which, if the product is not handled correctly, will result in death or serious injury.	 Danger
Warning	This indicates a potentially hazardous situation which, if the product is not handled correctly, could result in death or serious injury.	 Warning
Caution	This indicates a potentially hazardous situation which, if the product is not handled correctly, may result in minor injury or property damage.	 Caution
Notice	This indicates lower possibility for the injury, but should be kept to use this product properly.	 Notice



## 1. Overview

PROFINET IO is an open field network of the industrial EtherNet. It is a standardized global open network specified by the IEC 61158 and IEC61748 series of international standards.

You can connect MSEL controllers to PROFINET IO to build a system with minimum wiring.

(Note 1) For detailed explanations of PROFINET, refer to the instruction manual for the programmable controller (hereinafter referred to as "PLC") in which the master unit is installed.

Use this instruction manual along with instruction manual of each controller.  
Usage other than the ones described in this instruction manual is prohibited.

### • System Configuration Example

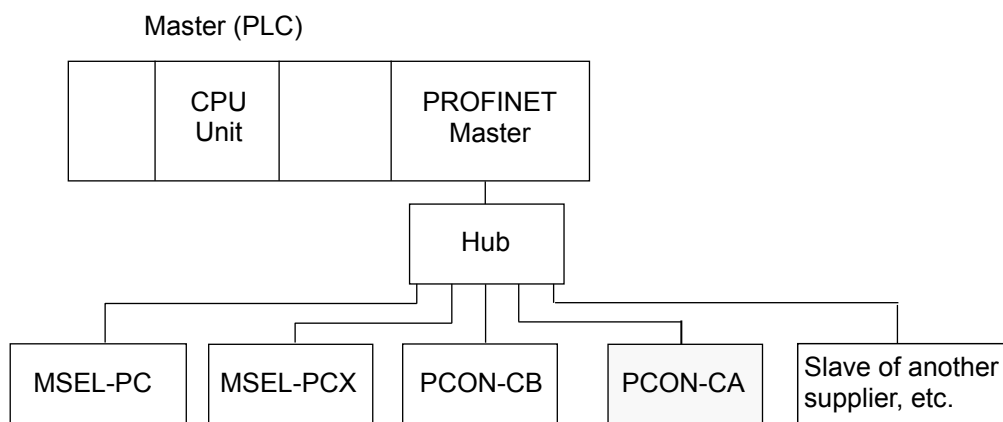

## 2. Specifications

Item	Specification
Conformance class	A (RT Communication)
Device class	IO device
Baud rate	100Mbps
Communication cable length	Distance between each segment: 100m or less
Number of connection	Depends on master unit
Applicable node address	0.0.0.0 to 255.255.255.255
Communications cable	Category 5 or above (Aluminum tape and braided double-shielded cable are recommended.)
Connector	RJ45 connector (1 per connector)

## 3. MSEL

### 3.1 Operation Modes and Functions

MSEL applicable for PROFINET-IO are applicable for the remote I/O control<sup>(\*)</sup> (240 points max. for each input and output).

- \*1 I/O port is controlled in one port unit. I/O port is a point to receive and send data located inside the controller. 1 port can handle data of 1 contact (1 bit). Data are sent and received via either PIO (24V input and output) or field network. Connection to one port is available from only one of PIO or field network. Set a parameter to determine which of PIO or field network is to be used.

#### • Operation Image

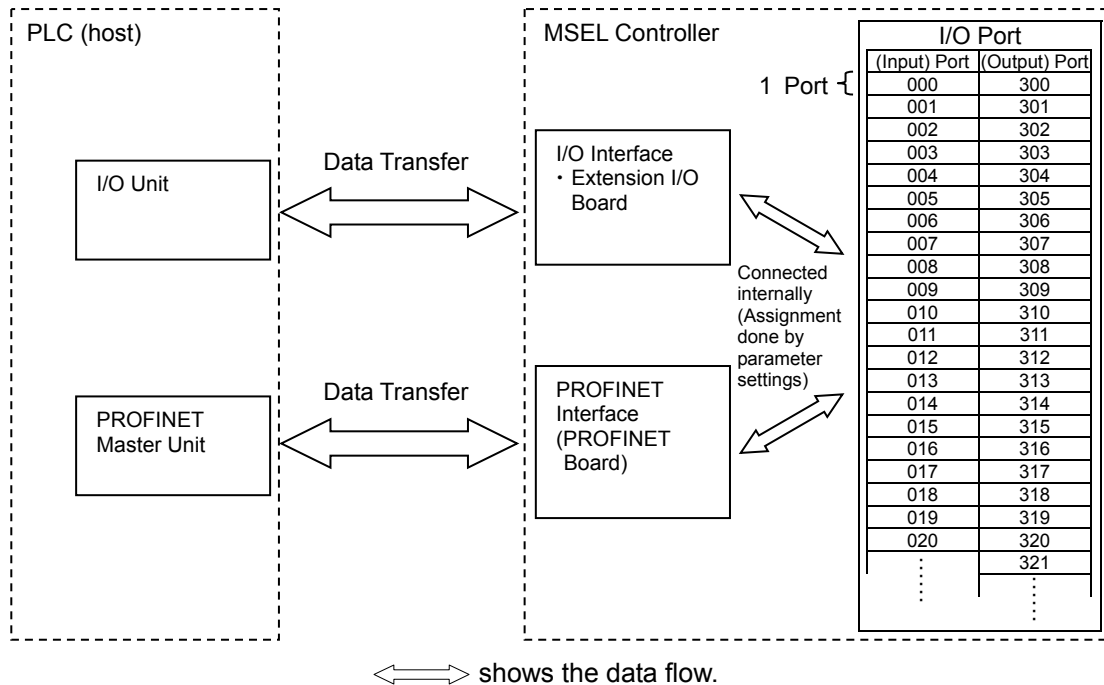

## 3.2 Model Numbers

The Model numbers of MSEL controllers applicable to PROFINET IO are described as follows.

- MSEL-PC□-□-PRT-□
- MSEL-PG□-□-PRT-□

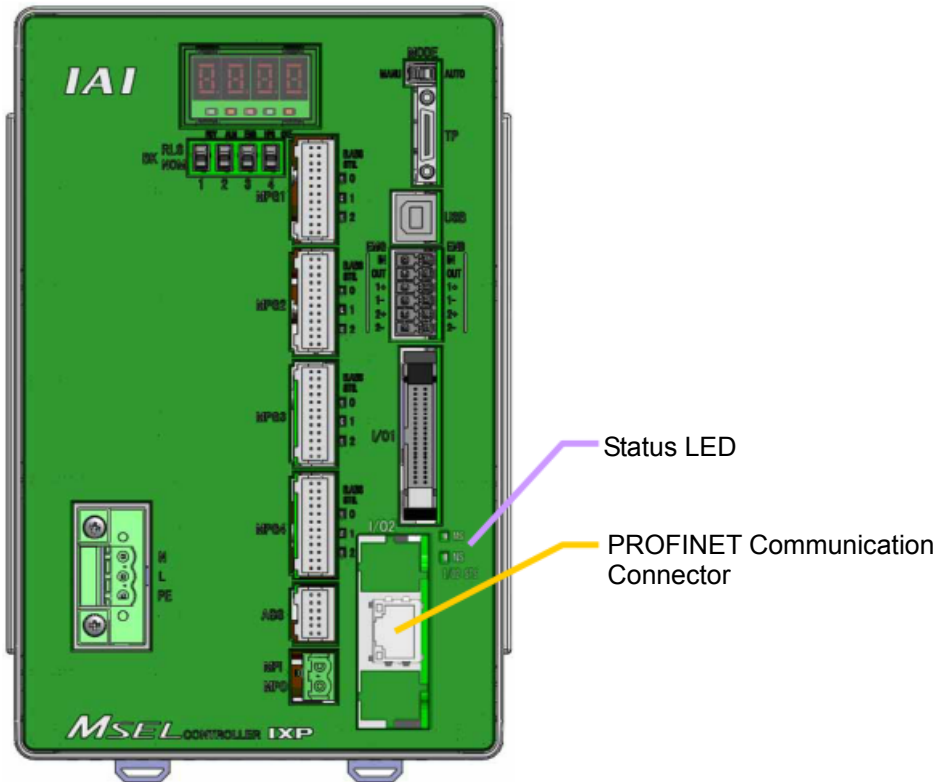

## 3.3 PROFINET-IO Interface

### 3.3.1 Names of the Parts

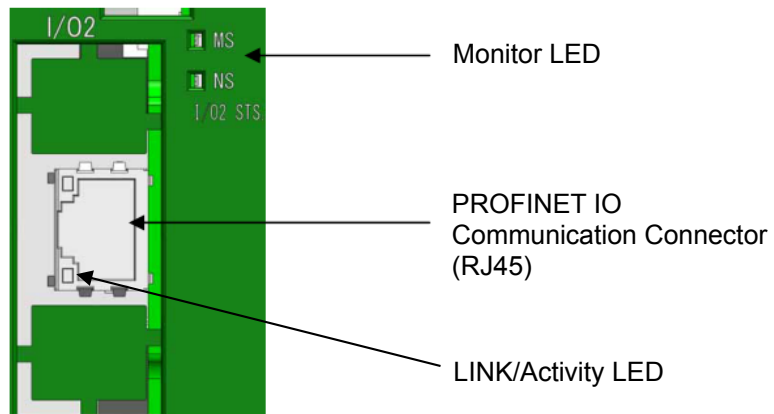

### 3.3.2 Monitor LED Indications

The controller condition, as well as network condition, can be checked using the two LEDs, MS and NS, provided on the front panel of the controller.

○ : Illuminating, × : OFF, ☆ : Flashing

Name	Color	Display	Explanation
MS	-	×	Power is OFF, or Initialization complete
		○	Operation is normal.
	Green	☆1	Communication under diagnosis
		☆2	Engineering tool identifying nodes
	Orange	○	Exceptional error
		☆1	There is an error in communication setting.
		☆2	There is an error in IP address setting.
		☆3	A wrong station name has been applied.
NS	-	×	Power is OFF, or there is no connectable controller.
		○	Connection has been established and proper communication is in progress. (in RUN condition)
	Green	☆	Connection is established but communication is paused (in STOP condition: network in normal condition).
		×	Not established Link
Link/Activity	Green	○	Link established (no communication)
		☆	In activity (communication)

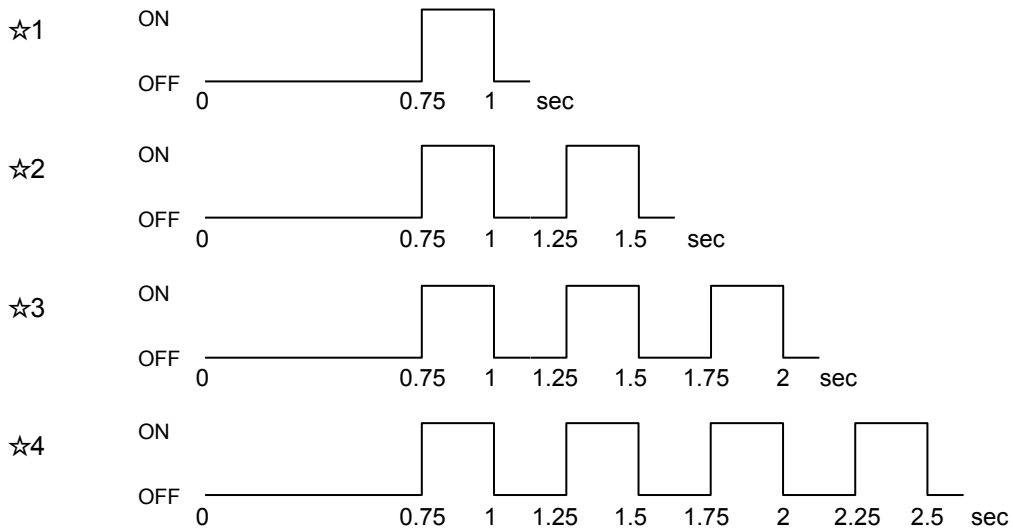

## 3.4 Wiring Example

### 3.4.1 Connection Diagram (Example)

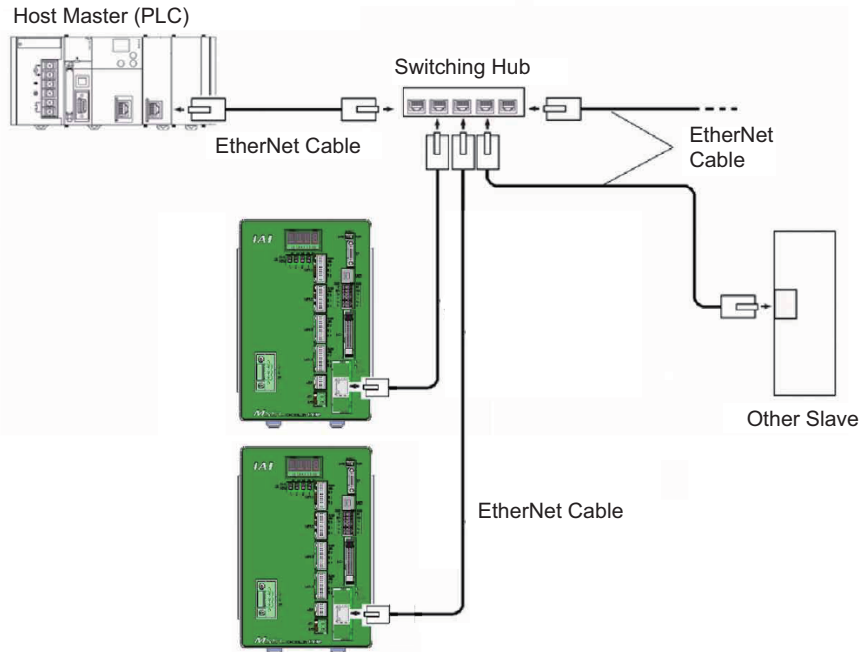

Note 1 It is recommended to choose a cable with a shield classified to Category 5e or higher for the EtherNet cable.

### 3.4.2 Connector Pin Layout

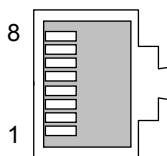

RJ45 8-pin modular connector (MSEL side)

Pin number	Signal name	Signal abbreviation
1	Data transmitted +	TD+
2	Data transmitted -	TD-
3	Data received +	RD+
4	Not used	
5	Not used	
6	Data received -	RD-
7	Not used	
8	Not used	
Connector hood	Grounding pin for security	FG

## 3.5 Setting

Using the teaching tool, set controller parameters of MSEL.  
Set the mode toggle switch on the front panel to "MANU" side.

### 3.5.1 Parameter Setting

#### [1] Check of Network Module Type

Confirm that the 1<sup>st</sup> digit of I/O Parameter No.225 Extension I/O Control setting is showing "A" (PROFINET-IO).

No.	Parameter name	Default	Input Range	Unit	Remarks
225	Extension I/O Control	*Ah	For reference only	-	Bit 0 to 3: I/O2 Module Type Bit 4 to 7: I/O3 Module Type (0h: Not Mounted 1h: CC-Link, 2h: DeviceNet, 3h: PROFIBUS, 4h to 5h: System Reservation, 6h: EtherCAT®, 7h: EtherNet/IP, 8h: System Reservation, 9h: PIO Ah: PROFINET-IO)

#### [2] Node Address Setting

It should be established on the master side. It is not necessary to establish setting on the IAI controller side.  
Refer to the instruction manual of host unit.

#### [3] Baud Rate Setting

It is unnecessary to establish the baud rate setting. It is fixed to 100Mbps.

#### [4] I/O Port Assignment Classification Setting

Check the I/O port assignment classification setting is "0" to I/O Parameter No.1.

No.	Parameter name	Default (reference)	Input Range	Unit	Remarks
1	I/O Port Allocation Type	0	For reference only	-	0: Fixed Allocation

#### [5] Number of I/O Port Setting

Set the number of ports to be used for I/O Parameters No.14 to 15.  
Set a number that is a multiple of 16.

No.	Parameter name	Default (reference)	Input Range	Unit	Remarks
14	I/O2 Fieldbus Number of Remote Input Ports	0	0 to 240	-	Multiples of 16
15	I/O2 Fieldbus Number of Remote Output Ports	0	0 to 240	-	Multiples of 16

(Note) It is recommended to set a multiple of 16 for the number of used ports in I/O Parameters No. 14 and 15. It is because it is necessary to use 1-word (16-bit) module of I/O for MSEL occupation in the network configuration of PROFINET.  
If the numbers in I/O Parameters No. 14 and 15 are not set to a multiple of 16, the I/O size for MSEL occupation will be moved up to a multiple of 16 bits. [Refer to 3.8 Caution]

[6] I/O Port Top Number Setting

Set the top port number of the port range used in I/O Parameters No.16 to 17.  
The values entered into these parameters must be evenly divisible by 8.

No.	Parameter name	Default (reference)	Input Range	Unit	Remarks
16	I/O2 Fix-Allocated Input Port Start No.	-1	-1 to 299	-	0 + (Multiples of 8) (0 to 299) (Unavailable when it is negative figure)
17	I/O2 Fix-Allocated Output Port Start No.	-1	-1 300 to 599	-	300 + (Multiples of 8) (300 to 599) (Unavailable when it is negative figure)

[7] PROFINET-IO Board Use Setting

Set "1" (Monitoring: use PROFINET-IO board) to I/O Parameter No.18.

No.	Parameter name	Default (reference)	Input Range	Unit	Remarks
18	I/O2 Error Monitor	1	0 to 5	-	0: No Monitoring (Not to use PROFINET-IO board) 1: Monitoring (use PROFINET-IO board)

[8] Time Adjustment to Wait for MSEL Link Establishment

Standby time to wait for the link to the master at the MSEL startup is available to adjust. When the setting value is C8H for example, it waits for 20s at the maximum for the establishment of the link with the master since the network I/F initialization. Change this setting when MSEL starts faster than the network master, which results in a generation of "A6B/D5D: Fieldbus Error (FBRS Link Error)" etc. can be used in time adjustment.

No.	Parameter name	Default (reference)	Input Range	Unit	Remarks
121	Network Attribute 2	C80000 <sub>H</sub>	0H to FFFFFFF <sub>H</sub>	-	Bit 16 to 27: Value of Link Timeout at Fieldbus Initializing (100msec)

[9] Select the Input Port Data at Link Error (Remote I/O Communication)

It is available to select if having the input port data of MSEL at link error to be cleared or to be held (remained). When the setting value is 0H for example, the MSEL input port data for the applicable network to use at a link error is 0.

No.	Parameter name	Default (reference)	Input Range	Unit	Remarks
120	Network Attribute 1	640001 <sub>H</sub>	0H to FFFFFFF <sub>H</sub>	-	Bit 28 to 31: I/O2 Fieldbus link error/ Input port data select at PIO power supply error (0: Clear, 1: Hold)

## 3.5.2 Example for Parameter Settings

Example for the case standard I/O and PROFINET-IO are used at the same time

This is a setting to use standard I/O board (16 points each for input and output) and PROFINET-IO on extension I/O1 (I/O2) at 240 points of each for input and output.

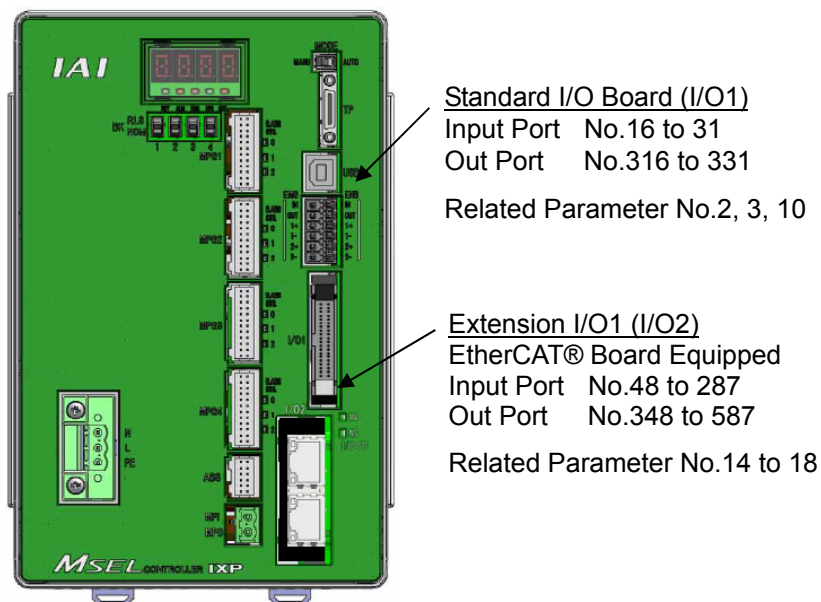

### • I/O Parameter

No.	Parameter name	Default (reference)	Input Range	Unit	Remarks
1	I/O Port Allocation Type	0	For reference only	0	0: Fixed Allocation
2	I/O1 Fix-Allocated Input Port Start No.	0	-1 to 299	0	0 + (Multiples of 8) [Ineffective when -1 is selected]
3	I/O1 Fix-Allocated Output Port Start No.	300	-1 300 to 599	300	300 + (Multiples of 8) [Ineffective when -1 is selected]
10	I/O1 Error Monitoring	1	0 to 5	0	0: No Monitoring (Not to use I/O board) 1: Monitoring 2: Monitoring (Not to monitor 24V I/O power related error) 3: Monitoring (To monitor only 24V I/O power related error)
14	I/O2 Fieldbus Number of Remote Input Ports	64	0 to 240	240	Multiples of 16
15	I/O2 Fieldbus Number of Remote Output Ports	64	0 to 240	240	Multiples of 16
16	I/O2 Fix-Allocated Input Port Start No.	48	-1 to 299	48	0 + (Multiples of 8) [Ineffective when -1 is selected]
17	I/O2 Fix-Allocated Output Port Start No.	348	-1 300 to 599	348	300 + (Multiples of 8) [Ineffective when -1 is selected]
18	I/O2 Error Monitoring	1	0 to 5	1	0: No Monitoring (Not to use I/O2 module) 1: Monitoring

No.	Parameter name	Default (reference)	Input Range	Unit	Remarks
120	Network Attribute 1	640001 <sub>H</sub>	0 to FFFFFFFF <sub>H</sub>	Optional	Bit 28 to 31: I/O2 Fieldbus Link Error / Input Port Data Select at PIO Power Supply Error (0: Clear, 1: Hold)
121	Network Attribute 2	C80000 <sub>H</sub>	0 to FFFFFFFF <sub>H</sub>	Optional	Bit 16 to 27: Link Timeout Value at Fieldbus Initialization (100msec)
225	Extension I/O Control	*A <sub>H</sub>	00 <sub>H</sub> to 37 <sub>H</sub>	06	Bit 0 to 3: I/O2 Module Type A: PROFINET-IO

## 3.6 I/O Ports of MSEL

It is available to add special functions beside the general-purposed input and output in the I/O ports.

[Refer to MSEL Controller Operation Manual 2.2.5 PIO Circuit, Chapter 5 Parameter for the details.]

● I/O Port Setting at Delivery

Type	Port No.	Function	Type	Port No.	Function
Internal DI (I/O1)	000	For future expansion	Internal DO (I/O1)	300	ALM (LED on the front panel)
	001			301	RDY (LED on the front panel)
	002			302	EMG (LED on the front panel)
	003			303	For future expansion
	004			304	HPS (LED on the front panel)
	005			305	For future expansion
	006			306	
	007			307	
	008			308	
	009			309	
	010			310	
	011			311	
	012			312	
	013			313	
	014			314	
015	315				
External DI (I/O1)	016 to 031	General-purpose input	External DO (I/O1)	316 to 331	General-purpose output
Internal DI (I/O1)	032	For future expansion	Internal DO (I/O1)	332	7-segment user display digit specification
	033			333	7-segment user display digit specification
	034			334	For future expansion
	035			335	
	036			336	
	037			337	7-segment display refresh
	038			338	7-segment user/system alternate display
	039			339	7-segment user display specification
	040			340	DT0 (7-segment user display bit)
	041			341	DT1 (7-segment user display bit)
	042			342	DT2 (7-segment user display bit)
	043			343	DT3 (7-segment user display bit)
	044			344	DT4 (7-segment user display bit)
	045			345	DT5 (7-segment user display bit)
	046			346	DT6 (7-segment user display bit)
047	347	For future expansion			

Type	Port No.	Function	Type	Port No.	Function
External DI (PROFI NET IO)	048	Program start	External DO (PROFI NET IO)	348	Alarm output
	049	General-purpose input		349	Ready output
	050			350	Emergency stop output
	051			General-purpose output	351
	052				352
	053				353
	054				354
	055	Program number specification (BCD:1/BIN:1)*			355
	056	Program number specification (BCD:2/BIN:2)*			356
	057	Program number specification (BCD:4/BIN:4)*			357
	058	Program number specification (BCD:8/BIN:8)*			358
	059	Program number specification (BCD:10/BIN:16)*			359
	060	Program number specification (BCD:20/BIN:32)*			360
	061	Program number specification (BCD:40/BIN:64)*		361	
	062	General-purpose input		362	
063	363				
064 to 111	General-purpose input	364 to 411	General-purpose output		

\* Switching over between BCD and BIN in Program Number Indication should be conducted in IO Parameter No. 30 Input Function Select 000.

(1: Program Start BCD, 2: Program Start Binary (BIN))

(Note) Number of standard I/O ports is input 000 to 299 (300 points max.), and output 300 to 599 (300 points max.). Be careful of the number of I/O ports when using PROFINET-IO and PIO together.

## 3.7 I/O Port and Data Reading and Writing

The initial setting of SEL language commands for the operation of I/O (input and output) ports of MSEL is set to execute reading and writing without the data being exchanged.

Shown below is an example for the assignments on the PROFINET-IO master side and MSEL side.

[MSEL side output domain ⇒ PROFINET-IO master side input domain]

Address	Bit 7 (MSB)	6	5	4	3	2	1	0 (LSB)
MSEL Output Port Number	355	354	353	352	351	350	349	348
PROFINET-IO Input word address	0 (lower-order byte)							
MSEL Output Port Number	363	362	361	360	359	358	357	356
PROFINET-IO Input word address	0 (host byte)							
MSEL Output Port Number	371	370	369	368	367	366	365	364
PROFINET-IO Input word address	1 (lower-order byte)							
MSEL Output Port Number	379	378	377	376	375	374	373	372
PROFINET-IO Input word address	1 (host byte)							

⋮

- Example Data (1234h) from MSEL is changed to 1234h in PROFINET-IO.

MSEL	HEX	1	2	3	4
	BIN	0001	0010	0011	0100

↓ ↓

PROFINET-IO Master	HEX	1	2	3	4
	BIN	0001	0010	0011	0100

[PROFINET-IO master side output domain ⇒ MSEL side input domain]

Address	Bit 7 (MSB)	6	5	4	3	2	1	0 (LSB)
MSEL Input Port Number	55	54	53	52	51	50	49	48
PROFINET-IO Output word address	0 (lower-order byte)							
MSEL Input Port Number	63	62	61	60	59	58	57	56
PROFINET-IO Output word address	0 (host byte)							
MSEL Input Port Number	71	70	69	68	67	66	65	64
PROFINET-IO Output word address	1 (lower-order byte)							
MSEL Input Port Number	79	78	77	76	75	74	73	72
PROFINET-IO Output word address	1 (host byte)							

⋮

- Example Data (1234h) from PROFINET-IO master is changed to 1234h in MSEL.

PROFINET-IO Master	HEX	1	2	3	4
	BIN	0001	0010	0011	0100

↓ ↓

MSEL	HEX	1	2	3	4
	BIN	0001	0010	0011	0100

●Reference How to Read and Write with Swapping Host 8 Bits with Lower 8 Bits for Every 16-Bit Data

When conducting reading and writing with swapping the host 8 bits with lower 8 bits for every 16-bit data, set Format Type to 1 (Swap host 8 bits with lower 8 bits for every 16-bit data) with FMIO Command before executing an input and output port operation command such as IN Command and OUT Command in MSEL. [Refer to MSEL Operation Manual.]

Shown below is an example for the assignments on PROFINET-IO master side and MSEL controller side.

[PROFINET-IO master side output domain ⇒ MSEL side input domain]

Address	Bit 7 (MSB)	6	5	4	3	2	1	0 (LSB)
MSEL Input Port Number	355	354	353	352	351	350	349	348
PROFINET-IO Output bit address	63	62	61	60	59	58	57	56
PROFINET-IO Output word address	0 (host byte)							
MSEL Input Port Number	363	362	361	360	359	358	357	356
PROFINET-IO Output bit address	55	54	53	52	51	50	49	48
PROFINET-IO Output word address	0 (lower-order byte)							
MSEL Input Port Number	371	370	369	368	367	366	365	364
PROFINET-IO Output bit address	79	78	77	76	75	74	73	72
PROFINET-IO Output word address	1 (host byte)							
MSEL Input Port Number	371	370	369	368	367	366	365	364
PROFINET-IO Output bit address	71	70	69	68	67	66	65	64
PROFINET-IO Output word address	1 (lower-order byte)							

⋮

● Example Data (1234h) from PROFINET-IO master is changed to 3412h in MSEL.

PROFINET-IO Master	HEX	1	2	3	4
	BIN	0001	0010	0011	0100
MSEL	HEX	3	4	1	2
	BIN	0011	0100	0001	0010

## 3.8 Caution

- (1) It is necessary to register the I/O size of MSEL using 1-word (=2-byte) module in the configuration of PROFINET master.

• Table for Register Module on PLC Side in Network Configuration

I/O Parameter No.15 Setting Value	PLC Side Registered Module	I/O Parameter No.14 Setting Value	PLC Side Registered Module
0	-	0	-
8	Input 1 word×1	8	Output 1 word×1
16		16	
24	Input 1 word×2	24	Output 1 word×2
32		32	
40	Input 1 word×3	40	Output 1 word×3
48		48	
56	Input 1 word×4	56	Output 1 word×4
64		64	
72	Input 1 word×5	72	Output 1 word×5
80		80	
88	Input 1 word×6	88	Output 1 word×6
96		96	
104	Input 1 word×7	104	Output 1 word×7
112		112	
120	Input 1 word×8	120	Output 1 word×8
128		128	
136	Input 1 word×9	136	Output 1 word×9
144		144	
152	Input 1 word×10	152	Output 1 word×10
160		160	
168	Input 1 word×11	168	Output 1 word×11
176		176	
184	Input 1 word×12	184	Output 1 word×12
192		192	
200	Input 1 word×13	200	Output 1 word×13
208		208	
216	Input 1 word×14	216	Output 1 word×14
224		224	
232	Input 1 word×15	232	Output 1 word×15
240		240	

- (2) It is necessary to register in the order of Input Module and then Output Module in the configuration of PROFINET master.



## 4. Appendix

### 4.1 Troubleshooting

- (1) In case it is not possible to connect the network, check the current condition on the display of monitoring LEDs of PROFINET-IO Board. [Refer to Section 3.3.2.]  
Check the settings of the MSEL and the settings of the master unit referring to the operation manuals of the master unit.
- (2) When an alarm is issued, an alarm code gets output to the MSEL.
  - 1) Based on the read alarm code, search the alarm description list in the operation manual for the MSEL.
  - 2) Deal with it based on the description for the alarm code in question.  
The alarm codes listed below are those you will often see in the startup process.

◎ Alarm Codes in Common with XSEL

Monitor LED	Contents	Cause and Remedy
ErG	Emergency Stop	It is not an alarm. <ul style="list-style-type: none"> <li>• This occurs when the emergency stop switch of a teaching tool such as the PC software is not released.</li> <li>• It is generated when the personal computer cable is not connected to the emergency stop switch box.</li> <li>• Check the emergency stop circuit.</li> </ul>
Enb	Safety Gate Remains Opening Deadman Switch OFF	It is not an alarm. <ul style="list-style-type: none"> <li>• It is generated when the system I/O ENB signal is opened. Check the ENB signal. (It is generated when the safety gate is open. Close the safety gate.)</li> <li>• This occurs when AUTO/MANU switch is on MANU and no teaching tool such as a PC is connected. Connect the teaching pendant or set the AUTO/MANU switch to "AUTO".</li> <li>• When the actuator is to be started up, hold the deadman switch on the teaching pendant to turn it ON.</li> </ul>
ACF	AC Power Interruption Momentary Power Failure Power Voltage Drop	The power voltage is not supplied properly. Check the power supply.
E914	Absolute Data Backup Battery Voltage Error	It will be generated in the case that the battery has not been attached, or the battery voltage is dropped. In the case of the actuator for the single-axis robots or orthogonal robots with the absolute data specifications, it is generated when the power is connected for the first time. Perform the absolute reset.
ED12	Encoder Disconnection Error	It is generated when the cable is broken or the encode cable is not connected to the controller. Check the wiring.
ED19	Encoder Reception Time Out	It is generated when the encoder is broken down, the cable is broken or the encoder cable is not connected to the controller.
EE69 EE6C	24V I/O Error DO Output Current Error	It is generated when the +24V power for I/O is not supplied. Check the power supply.  (How to start up the controller without connecting the I/O 24V power) Set the I/O parameter No.10 to "0". (Note) I/O cannot be used.
ED5D	Fieldbus Error	This occurs when the network connection is not established. Check the parameters on MSEL controller and the parameters on PLC. (Way to boot the controller without connecting to PROFINET-IO) Set the I/O parameter No.18 to "0".

◎ Other Alarm Codes Related to EtherCAT®

● Message Level Error

No.	Error name	Contents / Counteractions
A6B	Fieldbus Error (FBRS Link Error)	FBRS Link Error was detected.

● Cold Start Level Errors

No.	Error name	Contents / Counteractions
678	Extension I/O Port Assignment Parameter Error	There is an error in a parameter related to the extended I/O port assignment.
679	Extended I/O Port Assignment Number Overflow Error	The number of extended I/O port assignment exceeded the specification range.
67A	Extended I/O Port Duplicated Assignment Error	Extended I/O port assignment has duplicated.
D5F	Network I/F Module Class Mismatch Error	The type of I/F module specified in I/O Parameter No.225 and the type of network module actually mounted do not match. Check the setting in I/O Parameter No.225 and the combination of network I/F module actually mounted.
D75	Fieldbus Parameter Error	There is a failure in the Fieldbus Parameter. Check in I/O Parameters No.226.
D76	Fieldbus Module Unmounted Error	Fieldbus Module is unmounted.
D77	Fieldbus Error (Exception)	The Exception Error was detected. Refer to the operation manual of the field network board and check the conditions of monitoring LEDs on the Fieldbus.
E1F	I/O Assignment Parameter Error	It can be concerned that a value other than the input and output port number (-1 is acceptable) or a value other than Input and Output Board Top No. + [a multiple of 8] is input in I/O Parameter No.2 to 9, or a value other than [a multiple of 8] is input in I/O Parameter No.14 to 17.
E20	I/O Duplication Assignment Error	I/O assignment is duplicated. Check I/O Parameter No.2 to 9, 14 to 17, card model code (input and output number) in the slot and so on.
E21	I/O Assignment Number Overflow Error	I/O assignment has exceeded the specified range. Check I/O Parameter No.2 to 9, 14 to 17, card model code (input and output number) in the slot and so on.
E8F	Fieldbus Logic Error	It is a logic error at the Fieldbus initializing.



## 4.2 List of PROFINET-IO Related Parameters

### I/O Parameter of MSEL

No.	Parameter Name	Default (reference)	Input Range	Unit	Remarks
1	I/O Port Allocation Type	0	For reference only	-	0: Fixed Allocation
14	I/O2 Fieldbus Number of Remote Input Ports	64	0 to 240	-	Multiples of 16
15	I/O2 Fieldbus Number of Remote Output Ports	64	0 to 240	-	Multiples of 16
16	I/O2 Fieldbus Fix-Allocated Input Port Start No.	48	-1 to 299	-	0 + (Multiples of 8) (0 to 299) (Unavailable when it is negative figure)
17	I/O2 Fieldbus Fix-Allocated Output Port Start No.	348	-1 300 to 599	-	300 + (Multiples of 8) (300 to 599) (Unavailable when it is negative figure)
18	I/O2 Fieldbus Error Monitoring	1	0 to 5	-	0: No Monitoring 1: Monitoring * There are some exceptions
120	Network Attribute 1	640001 <sub>H</sub>	0 <sub>H</sub> to FFFFFFF <sub>H</sub>	-	Bit 0 to 3 : System Reservation Bit 4 to 11 : I/O2 Fieldbus Link Error Check Timer Value (10ms) Bit 12 to 27 : System Reservation Bit 28 to 31 : I/O2 Fieldbus Link Error/Input Port Data Select at PIO Power Supply Error (0: Clear, 1: Hold)
121	Network Attribute 2	C80000 <sub>H</sub>	0 to FFFFFFF <sub>H</sub>	-	Bit 0 to 15 : System Reservation Bit 16 to 27 : Network Link Timeout Value at Initializing (100msec) Bit 28 to 31 : System Reservation
130	Local MAC Address (H)	0 <sub>H</sub>	For reference only (HEX)		Only bottom 2 bytes are valid
131	Local MAC Address (L)	0 <sub>H</sub>	For reference only (HEX)		
225	Extension I/O Control	*A <sub>H</sub>	For reference only (HEX)	-	Bit 0 to 3 : I/O2 Module Type (0h: Not Mounted 1h: CC-Link, 2h: DeviceNet, 3h: PROFIBUS, 4h to 5h: System Reservation, 6h: EtherCAT®, 7h: EtherNet/IP, 8h: System Reservation, 9h: PIO, A : PROFINET IO (Main Application V2.00 or later), B : System Reservation, C : Extension SIO (Main Application V2.00 or later), D to F : System Reservation)
227	I/O2 Fieldbus Baud Rate	0	0 to 9	-	• At CC-Link : (0 to 4) • At DeviceNet : (0 to 3) • At EtherNet/IP : (0 to 4) * Setting establishment not necessary for PROFIBUS, EtherCAT® and PROFINET

## 4.3 Network Setting File

It is necessary to use network setting file dedicated for controller. Please download from Download Support Page in IAI homepage.

## Change History

Revision Date	Description of Revision
2016.04	First edition
2018.05	Edition 1B 3.6 Contents revised in delivery setting table for I/O ports on MSEL





## ***IAI Corporation***

Head Office: 577-1 Obane Shimizu-KU Shizuoka City Shizuoka 424-0103, Japan  
TEL +81-54-364-5105 FAX +81-54-364-2589  
website: [www.iai-robot.co.jp/](http://www.iai-robot.co.jp/)

Technical Support available in USA, Europe and China

## ***IAI America, Inc.***

Head Office: 2690 W. 237th Street, Torrance, CA 90505  
TEL (310) 891-6015 FAX (310) 891-0815  
Chicago Office: 110 East State Parkway, Schaumburg, IL 60173  
TEL (847) 908-1400 FAX (847) 908-1399  
Atlanta Office: 1220 Kennestone Circle, Suite 108, Marietta, GA 30066  
TEL (678) 354-9470 FAX (678) 354-9471  
website: [www.intelligentactuator.com](http://www.intelligentactuator.com)

## ***IAI Industrieroboter GmbH***

Ober der Röth 4, D-65824 Schwalbach am Taunus, Germany  
TEL 06196-88950 FAX 06196-889524

## ***IAI (Shanghai) Co., Ltd.***

SHANGHAI JIAHUA BUSINESS CENTER A8-303, 808, Hongqiao Rd. Shanghai 200030, China  
TEL 021-6448-4753 FAX 021-6448-3992  
website: [www.iai-robot.com](http://www.iai-robot.com)

## ***IAI Robot (Thailand) Co., Ltd.***

825, PhairojKijja Tower 12th Floor, Bangna-Trad RD., Bangna, Bangkok 10260, Thailand  
TEL +66-2-361-4458 FAX +66-2-361-4456