

PS241/PS242

24V Power Supply

Instruction Manual

Fourth Edition





Please Read Before Use

Thank you for purchasing our product.

This instruction manual explains the handling methods, structure and maintenance of this product, providing the information you need in order to use the product safely.

Before using the product, be sure to read this manual and fully understand the contents explained herein to ensure safe use of the product.

Please download the user's manual from our website.

You can download it free of charge. User registration is required for the first time downloading.

URL : www.iai-robot.co.jp/data_dl/CAD_MANUAL/

When using the product, print out of the necessary portions of the relevant manual, or please display it on your computer, tablet terminal, etc. so that you can check it immediately.

After reading the instruction manual, keep it in a convenient place so that whoever is handling the product can refer to it quickly when necessary.

[Important]

- This Instruction Manual is original.
- The product cannot be operated in any way unless expressly specified in this Instruction Manual. IAI shall assume no responsibility for the outcome of any operation not specified herein.
- Information contained in this Instruction Manual is subject to change without notice for the purpose of product improvement.
- If you have any question or comment regarding the content of this manual, please contact the IAI sales office near you.
- Using or copying all or part of this Instruction Manual without permission is prohibited.
- The company names, names of products and trademarks of each company shown in the sentences are registered trademarks.



Table of Contents

Safety Guide.....	1
Precautions in Handling.....	7
1. Name and Function of Each Part	9
2. RDY Display and RDY Output Signal.....	11
3. Product Check.....	12
3.1 Parts (The option is excluded.)	12
3.2 Instruction Manuals related to this product	12
3.3 How to read the model plate	12
3.4 How to read the model No.	12
4. Basic Specifications	13
5. External Dimensions	14
6. Installation Environment.....	15
7. Installation and Noise Elimination	16
8. Output Voltage	18
9. Protective Functions.....	19
10. Parallel Operation.....	20
11. Simple Troubleshooting.....	21
Appendix 1.....	22
Relation of Actuator and Power Supply Current	
Output Current for When Connecting Multiple Power Supply Units	
Appendix 2.....	30
Determination for Number of Connectable Units	
How to Calculate Power Supply Capacity	
Warranty Period and Scope of Warranty.....	32
Change History.....	33

Safety Guide

"Safety Guide" has been written to use the machine safely and so prevent personal injury or property damage beforehand. Make sure to read it before the operation of this product.

Safety Precautions for Our Products

The common safety precautions for the use of any of our robots in each operation.

No.	Operation Description	Precautions
1	Model Selection	<ul style="list-style-type: none"> ● This product has not been planned and designed for the application where high level of safety is required, so the guarantee of the protection of human life is impossible. Accordingly, do not use it in any of the following applications. <ol style="list-style-type: none"> 1) Medical equipment used to maintain, control or otherwise affect human life or physical health. 2) Mechanisms and machinery designed for the purpose of moving or transporting people (For vehicle, railway facility or air navigation facility) 3) Important safety parts of machinery (Safety device, etc.) ● Do not use it in any of the following environments. <ol style="list-style-type: none"> 1) Location where there is any flammable gas, flammable object or explosive 2) Place with potential exposure to radiation 3) Location with the ambient temperature or relative humidity exceeding the specification range 4) Location where radiant heat is added from direct sunlight or other large heat source 5) Location where condensation occurs due to abrupt temperature changes 6) Location where there is any corrosive gas (sulfuric acid or hydrochloric acid) 7) Location exposed to significant amount of dust, salt or iron powder 8) Location subject to direct vibration or impact ● Do not use the product outside the specifications. Failure to do so may considerably shorten its life and cause a product breakdown or facility operation stop.
2	Transportation	<ul style="list-style-type: none"> ● Consider well so that it is not bumped against anything or dropped during the transportation. ● Transport it using an appropriate transportation measure. ● Do not step or sit on the package. ● Do not put any heavy thing that can deform the package, on it. ● When using a crane capable of 1t or more of weight, have an operator who has qualifications for crane operation and sling work. ● When using a crane or equivalent equipments, make sure not to hang a load that weighs more than the equipment's capability limit. ● Use a hook that is suitable for the load. Consider the safety factor of the hook in such factors as shear strength. ● Do not get on the load that is hung on a crane. ● Do not leave a load hung up with a crane. ● Do not stand under the load that is hung up with a crane.



No.	Operation Description	Precautions
3	Storage and Preservation	<ul style="list-style-type: none"> ● The storage and preservation environment conforms to the installation environment. ● However, especially give consideration to the prevention of condensation.
4	Installation and Start	<p>(1) Installation of Robot Main Body and Controller, etc.</p> <ul style="list-style-type: none"> ● Make sure to securely hold and fix the product (including the work). A fall, drop or abnormal motion of the product may cause damage or injury. ● Do not get on or put anything on the product. Failure to do so may cause an accidental fall, injury or damage to the product due to a drop of anything, malfunction of the product, performance degradation, or shortening of its life. ● When using the product in any of the places specified below, provide a sufficient shield. <ol style="list-style-type: none"> 1) Location where electric noise is generated 2) Location where high electrical or magnetic field is present 3) Location with the mains or power lines passing nearby 4) Location where the product may come in contact with water, oil or chemical droplets <p>(2) Cable Wiring</p> <ul style="list-style-type: none"> ● Use our company's genuine cables for connecting between the actuator and controller, and for the teaching tool. ● Do not scratch the cable. Do not bend it forcibly. Do not pull it. Do not coil it around. Do not insert it. Do not put any heavy thing on it. Failure to do so may cause a fire, electric shock or malfunction due to leakage or continuity error. ● Perform the wiring for the product, after turning OFF the power to the unit, so that there is no wiring error. ● When the direct current power (+24V) is connected, take the great care of the directions of positive and negative poles. If the connection direction is not correct, it might cause a fire, product breakdown or malfunction. ● Connect the cable connector securely so that there is no disconnection or looseness. Failure to do so may cause a fire, electric shock or malfunction of the product. ● Never cut and/or reconnect the cables supplied with the product for the purpose of extending or shortening the cable length. Failure to do so may cause the product to malfunction or cause fire. <p>(3) Grounding</p> <ul style="list-style-type: none"> ● Make sure to perform the grounding of type D (Former Type 3) for the controller. The grounding operation should be performed to prevent an electric shock or electrostatic charge, enhance the noise-resistance ability and control the unnecessary electromagnetic radiation.



No.	Operation Description	Precautions
4	Installation and Start	<p>(4) Safety Measures</p> <ul style="list-style-type: none">● When the product is under operation or in the ready mode, take the safety measures (such as the installation of safety and protection fence) so that nobody can enter the area within the robot's movable range. When the robot under operation is touched, it may result in death or serious injury.● Make sure to install the emergency stop circuit so that the unit can be stopped immediately in an emergency during the unit operation.● Take the safety measure not to start up the unit only with the power turning ON. Failure to do so may start up the machine suddenly and cause an injury or damage to the product.● Take the safety measure not to start up the machine only with the emergency stop cancellation or recovery after the power failure. Failure to do so may result in an electric shock or injury due to unexpected power input.● When the installation or adjustment operation is to be performed, give clear warnings such as "Under Operation; Do not turn ON the power!" etc. Sudden power input may cause an electric shock or injury.● Take the measure so that the work is not dropped in power failure or emergency stop.● Wear protection gloves, goggle or safety shoes, as necessary, to secure safety.● Do not insert a finger or object in the openings in the product. Failure to do so may cause an injury, electric shock, damage to the product or fire.● When releasing the brake on a vertically oriented actuator, exercise precaution not to pinch your hand or damage the work parts with the actuator dropped by gravity.
5	Teaching	<ul style="list-style-type: none">● Perform the teaching operation from outside the safety protection fence, if possible. In the case that the operation is to be performed unavoidably inside the safety protection fence, prepare the "Stipulations for the Operation" and make sure that all the workers acknowledge and understand them well.● When the operation is to be performed inside the safety protection fence, the worker should have an emergency stop switch at hand with him so that the unit can be stopped any time in an emergency.● When the operation is to be performed inside the safety protection fence, in addition to the workers, arrange a watchman so that the machine can be stopped any time in an emergency. Also, keep watch on the operation so that any third person can not operate the switches carelessly.● Place a sign "Under Operation" at the position easy to see.● When releasing the brake on a vertically oriented actuator, exercise precaution not to pinch your hand or damage the work parts with the actuator dropped by gravity. <p>* Safety protection Fence : In the case that there is no safety protection fence, the movable range should be indicated.</p>



No.	Operation Description	Precautions
6	Trial Operation	<ul style="list-style-type: none">• After the teaching or programming operation, perform the check operation one step by one step and then shift to the automatic operation.• When the check operation is to be performed inside the safety protection fence, perform the check operation using the previously specified work procedure like the teaching operation.• Make sure to perform the programmed operation check at the safety speed. Failure to do so may result in an accident due to unexpected motion caused by a program error, etc.• Do not touch the terminal block or any of the various setting switches in the power ON mode. Failure to do so may result in an electric shock or malfunction.
7	Automatic Operation	<ul style="list-style-type: none">• Before the automatic operation is started up, make sure that there is nobody inside the safety protection fence.• Before the automatic operation is started up, make sure that all the related peripheral machines are ready for the automatic operation and there is no error indication.• Make sure to perform the startup operation for the automatic operation, out of the safety protection fence.• In the case that there is any abnormal heating, smoke, offensive smell, or abnormal noise in the product, immediately stop the machine and turn OFF the power switch. Failure to do so may result in a fire or damage to the product.• When a power failure occurs, turn OFF the power switch. Failure to do so may cause an injury or damage to the product, due to a sudden motion of the product in the recovery operation from the power failure.
8	Maintenance and Inspection	<ul style="list-style-type: none">• Perform the work out of the safety protection fence, if possible. In the case that the operation is to be performed unavoidably inside the safety protection fence, prepare the "Stipulations for the Operation" and make sure that all the workers acknowledge and understand them well.• When the work is to be performed inside the safety protection fence, turn OFF the power switch.• When the operation is to be performed inside the safety protection fence, the worker should have an emergency stop switch at hand with him so that the unit can be stopped any time in an emergency.• When the operation is to be performed inside the safety protection fence, in addition to the workers, arrange a watchman so that the machine can be stopped any time in an emergency. Also, keep watch on the operation so that any third person can not operate the switches carelessly.• Place a sign "Under Operation" at the position easy to see.• For the grease for the guide or ball screw, use appropriate grease according to the Instruction Manual for each model.• Do not perform the dielectric strength test. Failure to do so may result in a damage to the product.• When releasing the brake on a vertically oriented actuator, exercise precaution not to pinch your hand or damage the work parts with the actuator dropped by gravity. <p>* Safety Protection Fence : In the case that there is no safety protection fence, the movable range should be indicated.</p>







No.	Operation Description	Precautions
9	Modification	<ul style="list-style-type: none">• Do not modify, disassemble, assemble or use of maintenance parts not specified based at your own discretion.• In such case, the warranty is not applied.
10	Disposal	<ul style="list-style-type: none">• When the product becomes no longer usable or necessary, dispose of it properly as an industrial waste.• Do not put the product in a fire when disposing of it. The product may burst or generate toxic gases.



Alert Indication

The safety precautions are divided into “Danger”-“Warning”-“Caution”-“Notice” according to the warning level, as follows, and described in the Instruction Manual for each model.

Level	Degree of Danger and Damage	Symbol
Danger	This indicates an imminently hazardous situation which, if the product is not handled correctly, will result in death or serious injury.	 Danger
Warning	This indicates a potentially hazardous situation which, if the product is not handled correctly, could result in death or serious injury.	 Warning
Caution	This indicates a potentially hazardous situation which, if the product is not handled correctly, may result in minor injury or property damage.	 Caution
Notice	This indicates lower possibility for the injury, but should be kept to use this product properly.	 Notice



Precautions in Handling

- PS-24 Power Supplies are the power supply units dedicated for IAI controllers of the 24V DC type.
- There are 2 types, 100V AC and 200V AC specifications, for the input power.
- Even when lack of the power capacity is occurred, this power supply does not need to be replaced with another power supply with a bigger capacity. Another unit of this product can be added to the connection to perform a parallel operation. 5 units maximum can be connected.
- This power supply unit is designed to accept some voltage fluctuation ($24V \pm 10\%$) so that the unit can be used in a parallel operation.
- Do not attempt to connect several power supply units in parallel except for PS-24 power supply units. Also, do not attempt to connect in parallel with PSA-24/PSA-24L power supplies.
- Make sure that the connection to the I/O terminals is correctly established as shown in this Instruction Manual.
- When wiping off the dirt on the product, use a neutral detergent. Do not use alcohol otherwise it may damage the paint and silk print on the surface.



INTELLIGENT ACTUATOR



1. Name and Function of Each Part

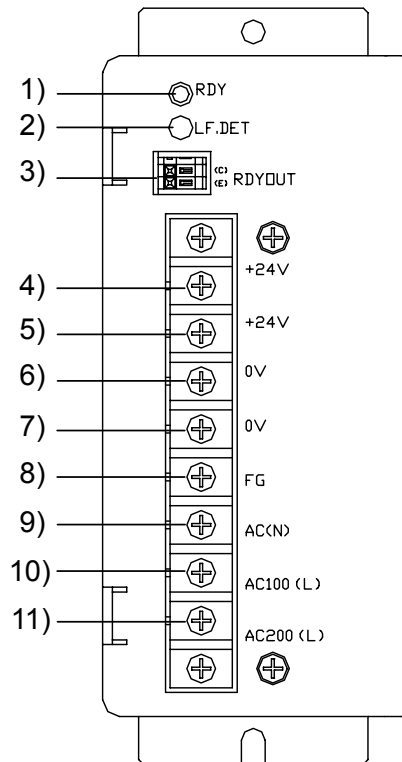

- 1) RDY display
It is illuminated in normal operation.
[Refer to "2. RDY Display and RDY Output Signal".]
- 2) Variable dial to set over load detection level
For manufacturer's use only. Do not remove the seal.
- 3) RDY output signal
It turns ON (electrically conducted) in normal operation.
[Refer to "2. RDY Display and RDY Output Signal".]
- 4) 5) +24V output terminal
* 4) and 5) are connected internally.
- 6) 7) 0V output terminal
* 6) and 7) are connected internally.
- 8) Frame ground terminal
It is the ground terminal that is connected to the power supply main housing.
- 9) AC input terminal
Input terminal common for 100V AC and 200V AC types.



- 10) AC input terminal (for 100V AC)
Input terminal for 100V AC type.

 Note : Do not connect the unit to a power source that is not specified.

- 11) AC input terminal (for 200V AC)
Input terminal for 200V AC type.

 Note : Do not connect the unit to a power source that is not specified.

(Note) Connect the power supply as follows;
for 100V AC input specification, 9) and 10), and
for 200V AC input specification, 9) and 11).
They cannot be used in common for each specification.

2. RDY Display and RDY Output Signal

In a normal operation, RDY display should be illuminated and RDY output signal should be turned ON (electrically conducted). In case this RDY display is not illuminated and RDY output signal is turned OFF, lower the load or add another unit of this power supply.

Take note that there are also other considerable causes that the RDY display light and RDY output signal are OFF as listed below.

- Output is stopped due to the effect of the over temperature protection circuit, over voltage protection circuit, etc.
- Input power is OFF or low

Also, there will be a failure in normal operation when the over current protection is working. RDY display and RDY output signal are linked to each other.

Power Status	RDY Output Signal	RDY Display
<ul style="list-style-type: none"> • In normal operation (When the load is under the specified value) 	ON	Illuminating
<ul style="list-style-type: none"> • Duty ratio exceeds the setting value • Output is stopped • Power is not input or low (• Over current detection circuit is working) 	OFF	OFF

Please make sure the power supply cable to use satisfies the following specifications:

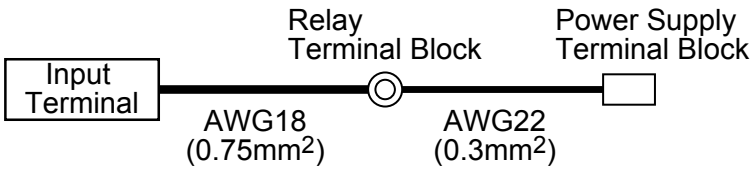
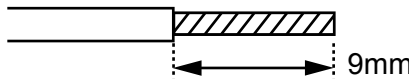
Item	Specification
Applicable wire	Twisted wire: AWG size 22 (0.3 mm ²) (copper wire) (Note) Pay attention to terminal treatment to avoid a short circuit resulting from chips. If the wire path is long, install a relay terminal block and change the wire size. 
Insulating sheath temperature rating	60°C or more
Stripped wire length	

RDY output signal is insulated with a photocoupler and is an open collector output.

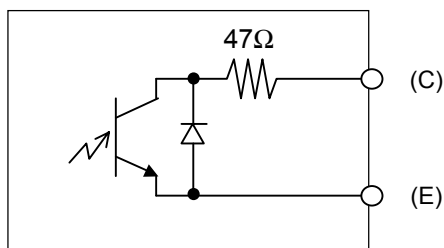

$V_{ceMAX} = 30V$

$I_{cMAX} = 20mA$

Residual voltage: approx. 1.6V (at $I_c = 20mA$)

(Note) If connecting this terminal in series, consider the residual voltage.



3. Product Check

This product is comprised of the following parts if it is of standard configuration.

If you find any fault in the contained model or any missing parts, contact us or our distributor.

3.1 Parts (The option is excluded.)

No.	Part Name	Model
1	24V Power Supply Main Unit	Refer to "How to read the model plate", "How to read the model No."
Accessories		
2	Safety Guide	

3.2 Instruction Manuals related to this product

No.	Name	Manual No.
1	PS241/PS242 24V Power Supply Instruction Manual	ME0129

3.3 How to read the model plate

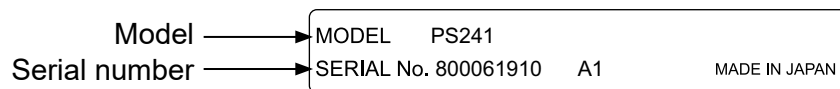

3.4 How to read the model No.



4. Basic Specifications

Specifications

Specification Item	100V AC Specification PS241	200V AC Specification PS242
Rated Voltage DC Output	24V±10% (fluctuates depending on duty)	
Rated DC Current Output	8.5A	
Peak DC Current Output	17A	
Rated Output Wattage	204W	
Efficiency	80%	
Rated Input Voltage (frequency)	100 to 115V AC (50/60Hz)	200 to 230V AC (50/60Hz)
Input Voltage Range	90 to 125V AC	180 to 250V AC
Input Current	3.5A (when total duty of 100V AC is applied)	1.8A (when total duty of 200V AC is applied)
Output Holding Time	20 [msec] (Condition; ambient temp. 25°C, rated input and output)	
Protection Circuit	Over current protection, over voltage protection, over temperature protection, over load protection	
Parallel Operation	Applicable	
Operation Ambient Temp.	0 to 50°C (with derating*1)	
Operation Ambient Humidity	30 to 85%RH (non-condensing)	
Cooling Method	Natural air-cooling	
Voltage Durability	Output – input ... 2000V AC 1min. Input – housing ... 2000V AC 1min.	
Insulation Strength	Output – housing ... 100MΩ min. at 500V DC	
Circuit System	Line-commutated flyback converter	
Mass	Approx. 0.9kg	

*1 Derating: it is a method to use a device with a load lower than the rated value for the purpose to decrease a risk of malfunction.



5. External Dimensions

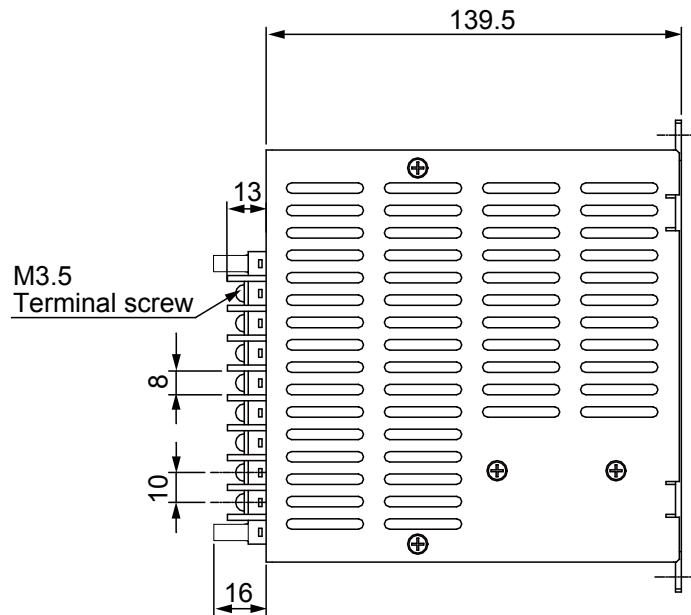
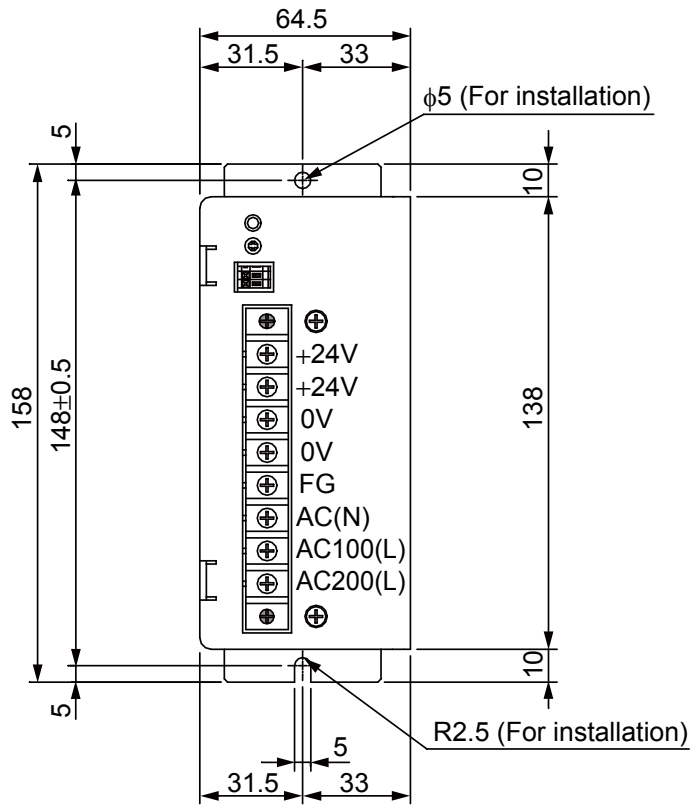



6. Installation Environment

Do not use this product in the following environment.

- Location where the surrounding air temperature exceeds the range of 0 to 50°C
- Location where condensation occurs due to abrupt temperature changes
- Relative humidity less than 30%RH or greater than 85%RH
- Location exposed to corrosive gases or combustible gases
- Location exposed to significant amount of dust, salt or iron powder
- Location subject to direct vibration or impact
- Location exposed to direct sunlight
- Location where the product may come in contact with water, oil or chemical droplets

When using the product in any of the locations specified below, provide a sufficient shield.

- Location subject to electrostatic noise
- Location where high electrical or magnetic field is present
- Location with the mains or power lines passing nearby

7. Installation and Noise Elimination

1. Grounding

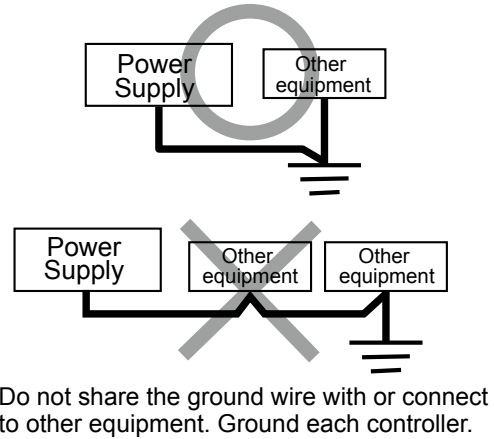
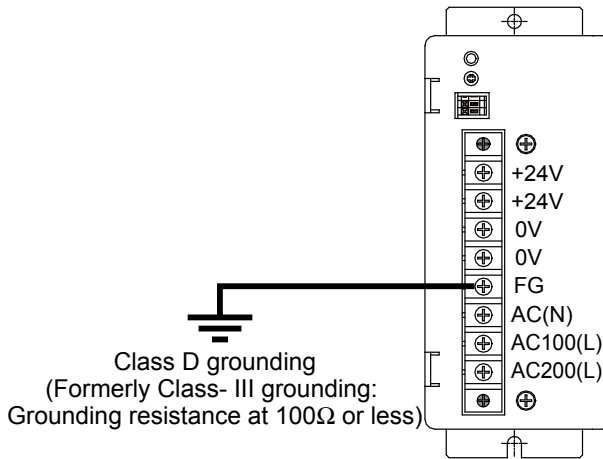

2. Heatsink and Mounting Method

This is a natural air-cooling type power supply. Mount the unit on a wall to make it vertical as shown in the picture below.

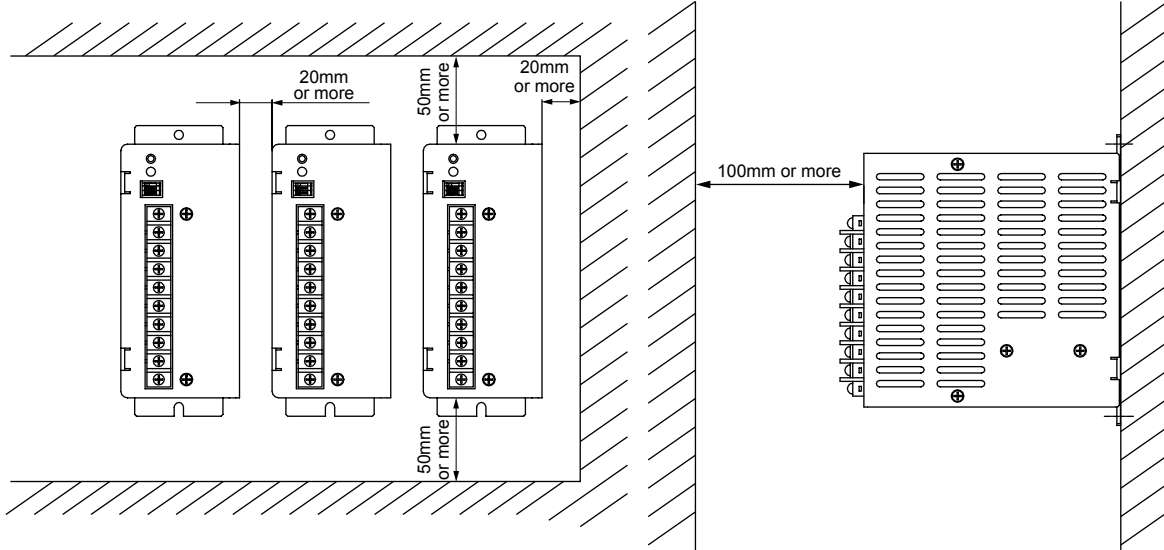



Both methods A (standard) and B below are available as a mounting method, however, the characteristics for the output current relevant to the temperature will differ for each way. Use within the range of its characteristics for each method.

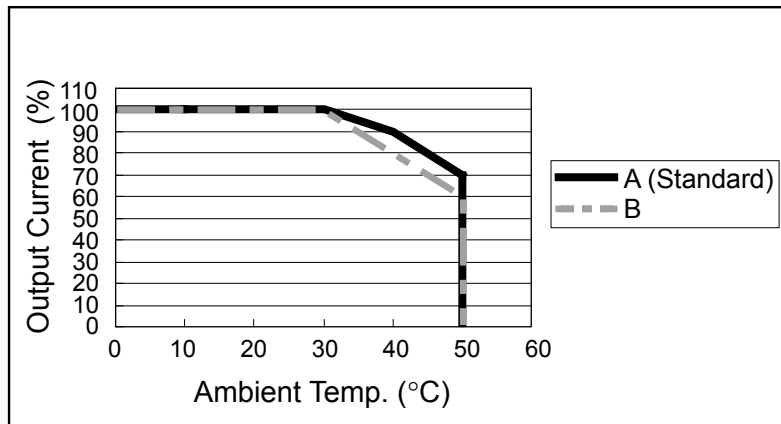
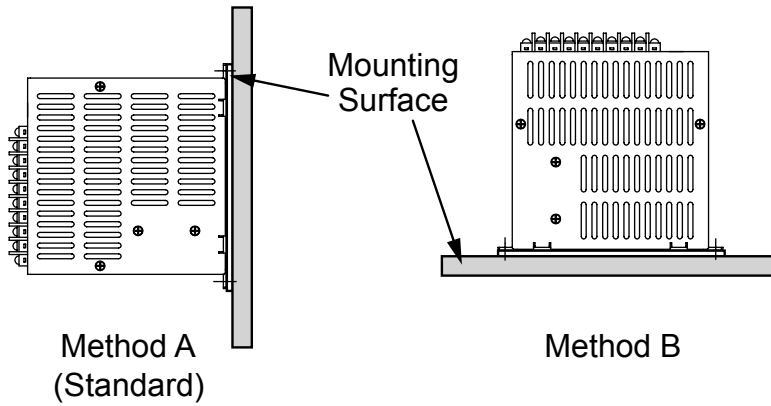

Note : The main housing of the product gets so hot that it sometimes gives you a burn as it works as a heat sink.

Do not touch while the power is ON, or even after the power is OFF until the heat calms down.

8. Output Voltage

This power supply is able to be used in a parallel operation, and the output voltage fluctuates within the range of $24V \pm 10\%$ even in a normal operation.

The voltage is set to around 25.8V at no duty. This voltage fluctuation does not influence the operation of IAI 24V controller at all.

This power supply changes the voltage within the area between the solid line and the broken line below in response to the load.

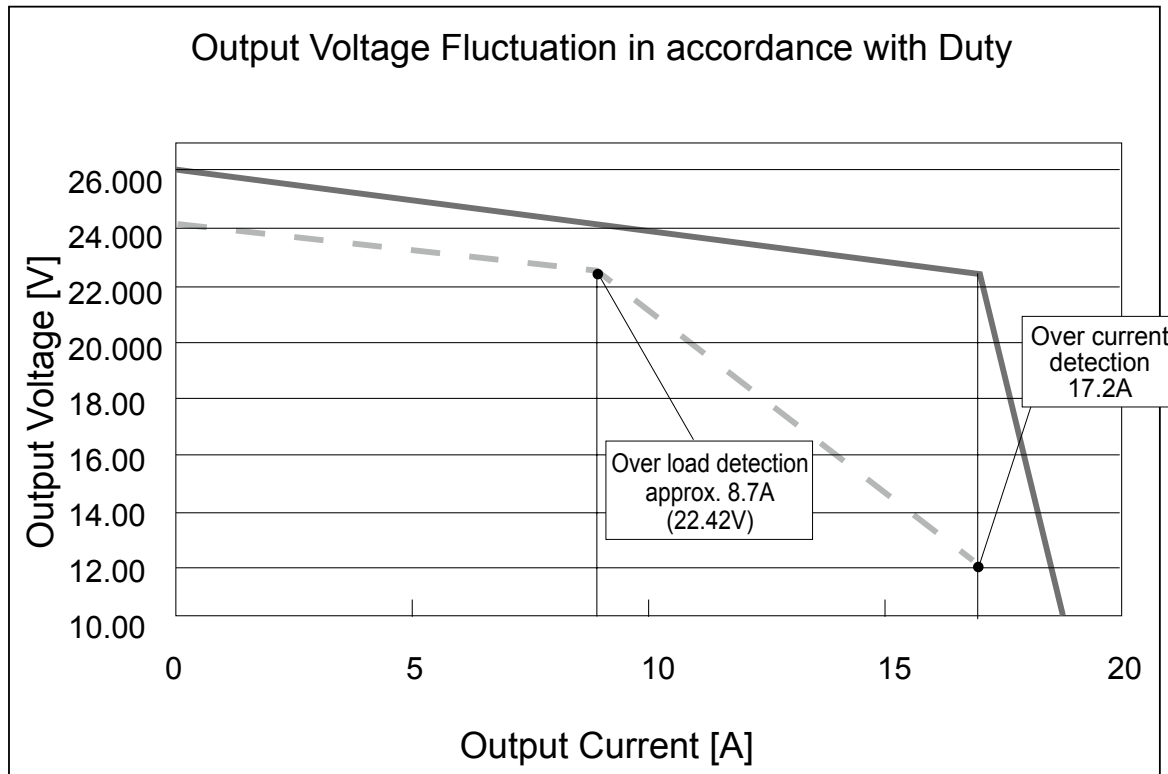



9. Protective Functions

There are 4 patterns of circuits prepared as a protection function.

(1) Over Current Protection Circuit

The voltage suddenly drops when the current more than the rated value is output (includes short circuit). Power output automatically recovers when the over current condition is cancelled.

There is a case that the over current protection circuit works due to the in-rush current caused by turning ON multiple controllers at the same time.

Described above is concerned as the cause of the phenomenon of sudden voltage drop occurring when turning ON each actuator controller, emergency stop being cancelled, and so on.

(What happens as the influence of the voltage drop is that it takes comparatively long time at the start-up of the controllers or canceling the emergency stop.)

In the case this is occurred, it is necessary to boost the controllers one by one, or add another power supply.

(2) Over Voltage Protection Circuit

The over voltage protection circuit works when the output voltage rises abnormally high. If the voltage continues to rise, it shuts down the output. To recover, shut down the input power first, leave it for approximately 2 minutes, and then input the power again.

When the over voltage protection works, internal devices may break. If output does not work properly even though trying to turn ON the power several times, it may require a repair. (Please contact us.)

(3) Over Temperature Protection Circuit

The over temperature protection circuit detects an abnormal rise of the ambient temperature and internal temperature (approx. 80°C), and shuts down the output.

To recover, shut down the input power first, leave it for a while till it cools down, and then input the power again. If the over temperature protection works often, lower the ambient temperature and the duty ratio.

(4) Over Load Detection

When the over load detection circuit works, the output drops with accordance with the duty. Output will recover with a lower duty. It operates when the current of approximately 8.7A or more continues to flow.

10. Parallel Operation

Parallel operation is available under the following conditions.

- Parallel operation is allowed up to 5 units. However, do not attempt to connect several power supply units in parallel except for PS-24 power supply units. Also, do not attempt to connect in parallel with PSA-24/PSA-24L power supplies.
- 2 terminals for each of positive side and negative side as the output terminals are provided. Use one terminal for the parallel connection, and the other for the connection to the load.
- When performing a parallel operation, turn ON the power for all the connected PS-24 Power Supply units at the same time. If the duty on one unit is too high, the over current detection circuit starts to work and may cause a failure in operation.
- Consider the connection of the power supplies to distribute the duty evenly to all the units so that a high duty is not applied on a single unit. Output voltage may drop with the in-rush current when the power is turned ON.
- Select a cable which has AWG18 (0.75sq) or more thickness for the load and transfer cables and the same thickness for all the cables considering the current. And, layout as short as possible.
- When connecting multiple units of power supply in parallel, the derating of output current is approximately 90%. Perform a parallel connection with confirming the current capacity.

1 unit.....	Rated 8.5A
2 units.....	Rated 15.3A (8.5A × 2 × 0.9)
3 units.....	Rated 22.95A (8.5A × 3 × 0.9)



Note : 1. When turning ON the power with no load, there is a case that a power supply does not turn ON the RDY display and RDY output signal. The power supply will operate in normal by connecting the load.
2. Series connection is not available.

- Make sure to separate the cables for the parallel connection of the power supply units from those connected to the load. Also, twisting the cables will improve the noise durability.

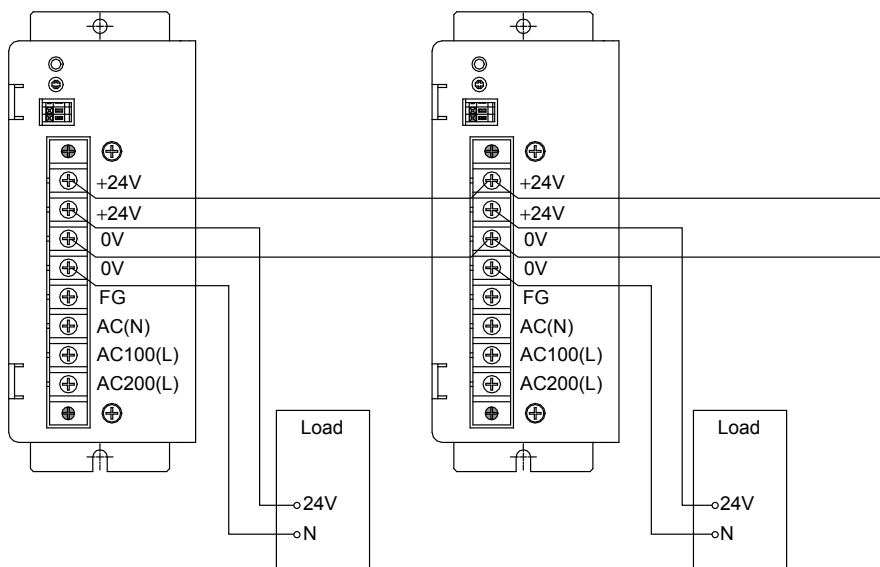

Parallel Connection



11. Simple Troubleshooting

Contents	Treatment
Voltage does not output.	<ul style="list-style-type: none">• Is the connected input voltage within the specification?• Any short circuit or grounding fault on the output circuit?• Time delay too short after over voltage or over temp protection activated.• Did you turn ON the power supply units at the same time for parallel operation?• Did you check that the ambient temperature is not high?• Is the load too big?
Output voltage is low.	<ul style="list-style-type: none">• Is the load too big?
RDY display does not illuminate.	<ul style="list-style-type: none">• Is the load too big?

Appendix 1

Relation of Actuator and Power Supply Current

Table: 1-1 Relation of Actuator and Power Supply Current

(□CON-C/CG/CY/PL/PO/SE, PCON-CF, □SEL, □SEP)

Controller Type	Actuator Type	Motor Power Capacity	Power Supply Current [A] ^(Note 1)	
ACON ^(Note 2) ASEL ^(Note 3) ASEP ^(Note 4)	RCL	2W	Rated	0.8
			Max.	4.6
		5W	Rated	1.0
			Max.	6.4
		10W	Rated	1.3
			Max.	6.4
	RCA RCA2	10W	Rated	1.3
			Max. Power Consumption	2.5
			Max.	4.4
		20W	Rated	1.3
			Max. Power Consumption	2.5
			Max.	4.4
		20W (Model Code Display 20S)	Rated	1.7
			Max. Power Consumption	3.4
Max.	5.1			
30W	Rated	1.3		
	Max. Power Consumption	2.2		
	Max.	4.0		
PCON ^(Note 3) PSEL ^(Note 4) PSEP ^(Note 4)	RCP2 RCP3	20P, 28P, 35P, 42P, 56P	Max.	2.0
PCON-CF		86P	Max.	6.0
DSEP ^(Note 4)	RCD	3W	Rated	0.7
			Max.	1.5

Note 1 The supply current for PCON should include the control supply current.

The supply current for those other than PCON should not include the control supply current.

Note 2 The control supply current for ACON should be 0.3A.

Note 3 The control supply current for ASEL/PSEL should be 1.2A.

The supply current for ASEL/PSEL should be the supply current for single-axis type. It should be twice as much for the double-axis type.

Note 4 The control supply current for ASEP/PSEP/DSEP should be 0.5A (0.8A for simple absolute type).

(Note) "Fieldbus Type" increases the current by 0.3A.

Table: 1-2 Relation of Actuator and Power Supply Current (□CON-CA/CB/CGB, PCON-CFA/CFB)

Controller Type	Actuator Type	Motor Power Capacity	Power Supply Current [A] ^(Note 1)			
ACON-CA ACON-CB	RCL	2W		Rated	0.8	
				Max.	4.6	
		5W		Rated	1.0	
				Max.	6.4	
		10W		Rated	1.3	
				Max.	6.4	
	RCA RCA2	10W		Rated	1.3	
				Max. Power Consumption	2.5	
				Max.	4.4	
				Rated	1.3	
		20W		Max. Power Consumption	2.5	
				Max.	4.4	
				Rated	1.7	
				Max. Power Consumption	3.4	
20W (Model Code Display 20S)		Max.	5.1			
		Rated	1.3			
		Max. Power Consumption	2.2			
		Max.	4.0			
DCON-CA DCON-CB	RCD	3W		Rated	0.7	
				Max.	1.5	
PCON-CA PCON-CB	RCP2 RCP3	20P, 20SP, 28P		Max.	1.0	
				Max.	2.2	
	RCP4 RCP5 RCP6	28P, 35P, 42P, 42SP, 56P		High-Output Setting Invalid	Max.	2.2
				High-Output Setting Valid	Rated	3.5
				Max.	4.2	
				Max.	4.2	
PCON-CFA PCON-CFB	RCP2 RCP3	60P, 86P		Max.	6.0	
	RCP4 RCP5 RCP6	56SP, 60P, 86P		Max.	6.0	

Note 1 The supply current should include the control supply current.

(Note) "Fieldbus Type" increases the current by 0.3A.

Table: 1-3 Relation of Actuator and Power Supply Current (□CON-CYB/PLB/POB)

Controller Type	Actuator Type	Motor Power Capacity	Power Supply Current [A] ^(Note 1)		
ACON-CYB ACON-PLB ACON-POB	RCL	2W	/	Reted	0.8
				Max.	4.6
		5W	/	Reted	1.0
				Max.	6.4
		10W	/	Reted	1.3
				Max.	6.4
	RCA RCA2	10W	/	Reted	1.3
				Max. Power Consumption	2.5
				Max.	4.4
		20W	/	Reted	1.3
				Max. Power Consumption	2.5
				Max.	4.4
		20W (Model Code Display 20S)	/	Reted	1.7
				Max. Power Consumption	3.4
30W	/	Max.	5.1		
		Reted	1.3		
		Max. Power Consumption	2.2		
DCON-CYB DCON-PLB DCON-POB	RCD	3W	/	Reted	0.7
				Max.	1.5
PCON-CYB PCON-PLB PCON-POB	RCP2 RCP3	20P, 20SP, 28P	/	Max.	1.0
		28SP, 35P, 42P, 56P		Max.	2.2
	RCP4 RCP5 RCP6	28P, 35P, 42P, 42SP, 56P	High-Output Setting Invalid	Max.	2.2
				Reted	3.5
			High-Output Setting Valid	Max	4.2

Note 1 The supply current should include the control supply current.

(Note) "Fieldbus Type" increases the current by 0.3A.

Table: 1-4 Relation of Actuator and Power Supply Current (MCON)

Controller Type	Actuator Type	Motor Power Capacity	Power Supply Current [A] ^(Note 1)				
MCON ^(Note 2)	RCL	2W		Rated	0.8		
				Max.	4.6		
		5W		Rated	1.0		
				Max.	6.4		
		10W		Rated	1.3		
				Max.	6.4		
	RCA RCA2	10W		Rated	1.3		
				Max. Power Consumption	2.5		
				Max.	4.4		
				20W		Rated	1.3
						Max. Power Consumption	2.5
						Max.	4.4
		20W (Model Code Display 20S)		Rated	1.7		
				Max. Power Consumption	3.4		
				Max.	5.1		
		30W		Rated	1.3		
				Max. Power Consumption	2.2		
				Max.	4.0		
RCD	3W		Rated	0.7			
			Max.	1.5			
RCP2 RCP3	20P, 28P, 28SP, 35P, 42P, 56P		Max.	2.0			
RCP4 RCP5 RCP6	28P, 35P, 42P, 42SP, 56P		High-Output Setting Invalid	Max.	2.0		
			High-Output Setting Valid	Rated	3.5		
				Max.	4.2		

Note 1 The supply current should be that for one axis which does not include the control supply current.

Note 2 The control supply current for MCON should be 1.0A. (Brake release current amperage not included)

(Note) “Fieldbus Type” increases the current by 0.3A.

For how to calculate the supply current, refer to “1.3 Calculation of Current Amperage” in MCON Instruction Manual.

Table: 1-5 Relation of Actuator and Power Supply Current (MSEP)

Controller Type	Actuator Type	Motor Power Capacity	Power Supply Current [A] ^(Note 1)		
MSEP ^(Note 2)	RCL	2W		Rated	0.8
				Max.	4.6
		5W		Rated	1.0
				Max.	6.4
		10W		Rated	1.3
				Max.	6.4
	RCA RCA2	10W		Rated	1.3
				Max. Power Consumption	2.5
				Max.	4.4
		20W		Rated	1.3
				Max. Power Consumption	2.5
				Max.	4.4
		20W (Model Code Display 20S)		Rated	1.7
				Max. Power Consumption	3.4
				Max.	5.1
		30W		Rated	1.3
				Max. Power Consumption	2.2
				Max.	4.0
RCD	3W		Rated	0.7	
			Max.	1.5	
RCP2 RCP3	20P, 28P, 28SP, 35P, 42P, 56P		Max.	2.0	
RCP4 RCP5	28P, 35P, 42P, 42SP, 56P	High-Output Setting Invalid	Max.	2.0	
			High-Output Setting Valid	Rated	3.5
				Max.	4.2

Note 1 The supply current should be that for one axis which does not include the control supply current.

Note 2 The control supply current for MSEP should be 1.0A. (Brake release current amperage not included)

(Note) "Fieldbus Type" increases the current by 0.3A.

For how to calculate the supply current, refer to "1.3 Calculation of Current Amperage" in MSEP Instruction Manual.

Table: 1-6 Relation of Actuator and Power Supply Current (Actuator with Integrated Controller)

Actuator Type	Motor Power Capacity	Power Supply Current [A] ^(Note 1)		
ELECYLINDER	EC-PR4, EC-GS4, EC-GD4, EC-TC4, EC-TW4		Max.	2.0
	Other than Above	Power Consumption Setting Valid	Max.	2.2
		Power Consumption Setting Invalid	Rated	3.5
ERC3		High-Output Setting Invalid	Max.	2.2
		High-Output Setting Valid	Rated	3.5
			Max.	4.2
RCP6S	35P, 42P, 56P	High-Output Setting Invalid	Max.	2.0
		High-Output Setting Valid	Rated	3.5
			Max.	4.5
	56SP, 60P		Max.	6.0

Note 1 The supply current should include the control supply current.

(Note) "Fieldbus Type" increases the current by 0.3A.

For how to calculate the current amperage for RCP6S Gateway System, refer to "1.3 Calculation for Connectable Number of Axes and Calculation for Current Amperage" in RCP6S Fieldbus Communication Instruction Manual.

Table: 1-7 Relation of Actuator and Power Supply Current (Controller for RCP6S Gateway)

Controller Type	Actuator Type	Motor Power Capacity	Power Supply Current [A] ^(Note 1)			
RCM-P6PC	RCP2 RCP3	20P, 20SP, 28P		Max.	1.0	
		28SP, 35P, 42P, 42SP, 56P		Max.	1.7	
	RCP4 RCP5 RCP6	28P, 35P, 42P, 42SP, 56P		High-Output Setting Invalid	Max.	1.7
				High-Output Setting Valid	Rated	3.2
					Max.	4.2
RCM-P6AC	RCL	2W		Rated	0.8	
				Max.	4.6	
		5W		Rated	1.0	
				Max.	6.4	
		10W		Rated	1.3	
				Max.	6.4	
	RCA RCA2	10W		Rated	1.3	
				Max. Power Consumption	2.5	
				Max.	4.4	
		20W		Rated	1.3	
				Max. Power Consumption	2.5	
				Max.	4.4	
		20W (Model Code Display 20S)		Rated	1.7	
				Max. Power Consumption	3.4	
				Max.	5.1	
30W		Rated	1.3			
		Max. Power Consumption	2.2			
		Max.	4.0			
RCM-P6DC	RCD	3W		Rated	0.7	
				Max.	1.5	

Note 1 The supply current should not include the control supply current. The control supply current should be 0.3A.

(Note) "Fieldbus Type" increases the current by 0.3A.

For how to calculate the current amperage for RCP6S Gateway System, refer to "1.3 Calculation for Connectable Number of Axes and Calculation for Current Amperage" in RCP6S Fieldbus Communication Instruction Manual.



Output Current for When Connecting Multiple Power Supply Units

Table: 2 Rated Output Current and Peak Output Current of Power Source

No. of Connectable Units	Rated Output Current [A]	Peak Output Current [A]
1 unit	8.5	17
2 units	15.3	30.6
3 units	22.95	45.9
4 units	30.6	61.2
5 units	38.25	76.5

(Note) For the 2nd unit or more, 10% safety factor (loss) is considered.

Output Current of One Unit × Connected Number of Units × 0.9



Appendix 2

Determination for Number of Connectable Units

Having the following calculation formulas for the current amperage [Calculation Formula for Rated Current and Peak Current] and [Necessary Number of Power Supply Units] as a reference, determine the number of units considering that the rated current and the peak current of the load fall into the allowable range of the power source.

- For how to calculate the supply current of MCON, refer to “1.3 Calculation of Current Amperage” in MCON Instruction Manual.
- For how to calculate the supply current of MSEP, refer to “1.3 Calculation of Current Amperage” in MSEP Instruction Manual.
- For how to calculate the current amperage for RCP6S Gateway System, refer to “1.3 Calculation for Connectable Number of Axes and Calculation for Current Amperage” in RCP6S Fieldbus Communication Instruction Manual.

There is the RDY display to detect the duty ratio on the power supply.

In case the following phenomenons occurred in the actual operation, operation should be available by having some more power sources joined in parallel connection.

- RDY display turns OFF [Refer to 2], or
- Overcurrent protection circuit works [Refer to 9. (1)]

How to Calculate Power Supply Capacity

[Calculation Formula for Rated Current and Peak Current]

Refer to tables from Table: 1-1 to Table: 1-7 in Appendix 1 for the rated current and maximum current for each actuator.

1. Models with No Description of Rated Current

All Rated Current [A] = Max. current for each actuator [A] × Number of actuator units
+ Control supply current for each controller [A] × Number of controller units

2. Models with Rated Current Described

All Rated Current [A] = Max. current for each actuator [A] × Number of actuator units
+ Control supply current for each controller [A] × Number of controller units

All Peak Current [A] = Max. current for each actuator [A] × Number of actuator units operated simultaneously + Control supply current for each controller [A] × Number of controller units

(Note) For the controllers that include the control supply current in “Current Amperage” shown in the tables from Table:1-1 to Table: 1-7, it is not necessary to add the control supply current for the controller.

(Note) If the controller is the fieldbus type, it is necessary to add amperage for $0.3A \times$ number of controller units.

[Number of Necessary Power Supply Units]

1. Figure out the number of necessary units from the all rated current and the rated output current of the used power source calculated in the previous section.---(A)
2. Figure out the number of necessary units from the all peak current and the peak output current of the used power source calculated in the previous section.---(B)
3. The larger number of units figured out in (A) or (B) should be the necessary number of units.

Example for Selection in PS-24

[Refer to Table: 2 in Appendix 1]

Power Supply	Connectable Units	1 unit	2 units	3 units	4 units	5 units
PS-241	Rated Output Current [A]	8.5	15.3	22.95	30.6	38.25
PS-242	Peak Output Current [A]	17.0	30.6	45.9	61.2	76.5

(Example 1) Models with No Description of Rated Current

- Case when connecting five sets of PCON-CB (PIO Type) and RCP5-RA7R (56P : High output setting invalid) and turning the servo on simultaneously:

<Rated Current>

$$2.2A \times 5 \text{ units} = 11.0A > 8.5A \Rightarrow \text{Capacity not enough}$$

$$(1) \text{ Power Supply Current} < 15.3A \Rightarrow \text{PS-24 : Two units necessary}$$

- * For the controllers that include the control supply current in Current Amperage (1) shown in the table for PCON-CB, it is not necessary to add the control supply current for the controller.

<Peak Current>

It is not necessary to calculate.

(Example 2) Models with Rated Current Described

- Case when connecting four sets of combination of ACON-C (Fieldbus Type) and RCA2-SA3C (10W) and turning the servo on simultaneously:

<Rated Current>

$$1.3A \times 4 \text{ units} + 0.3A \times 4 \text{ units} + 0.3A \times 4 \text{ units} = 7.6A > 8.5A \Rightarrow \text{PS-24 : One unit necessary}$$

$$(1) \text{ Power Supply Current} \quad (2) \text{ Control Supply Current} \quad (3) \text{ Fieldbus}$$

<Peak Maximum Current>

$$4.4A \times 4 \text{ units} + 0.3A \times 4 \text{ units} + 0.3A \times 4 \text{ units} = 20.0A > 17.0A \Rightarrow \text{Capacity not enough}$$

$$(1) \text{ Power Supply Current} \quad (2) \text{ Control Supply Current} \quad (3) \text{ Fieldbus} < 30.6A \Rightarrow \text{PS-24 : Two units necessary}^*$$

$$\text{Current} \quad \text{Current}$$

For the controllers that do not include the control supply current in Current Amperage (1) shown in the table for ACON-C, it is necessary to add Control Supply Current (2) for the controller. Also, if the controller is the fieldbus type, it is necessary to add 0.3A (3) on top.

When multiple actuators are operated in the same operation pattern with the maximum load and maximum acceleration speed at the same time

The rated current falls into 8.5A, but the peak current exceeds 17A, thus the capacity is not enough with one unit, and it is necessary to have two units connected in parallel.

However, it is still possible to drive with one unit if the two conditions described below are satisfied.

- Have several timings to turn the servo ON.
- Do not operate multiple actuators in the same operation pattern with the maximum load and maximum acceleration speed at the same time.



Warranty Period and Scope of Warranty

The controller you have purchased has passed IAI's shipping inspection implemented under the strictest standards. The product is covered by the following warranty:

1. Warranty Period

The warranty period expires upon elapse of one of the following periods, whichever is the shortest.

- 18 months after shipment from IAI.
- 12 months after delivery to the specified location.

2. Scope of Warranty

If a breakdown occurs within the period specified above due to defective material or poor craftsmanship, we will repair the actuator at no cost. However, the following items are not covered by this warranty:

- Faded paint or other changes that occur naturally over time.
- Consumable components that wear out with use (such as cables).
- The actuator is noisy or similar impressions that do not affect machinery performance.
- Defect caused by inappropriate handling or use by the user.
- Defect caused by inappropriate or erroneous maintenance/inspection.
- Defect caused by use of a part other than IAI's genuine part.
- Damage resulting from improper handling by the user or lack of proper maintenance. Alteration not made by IAI or its representatives.
- Damage caused by fire or other natural disaster or due to an accident.

The warranty pertains to the purchased product itself and does not cover any damage that might arise from a breakdown of the supplied product. All repairs will be done at our factory.

3. Covered Range for Services

The price of the product does not include the cost which may be caused by creating programs or sending an engineer. Therefore, we may need to ask for an extra charge for the following cases even if it is within the guarantee period.

- Maintenance/Inspection
- Technical instruction and education for operation skills and other related skills

Change History

Revision Date	Revision Description
2008.02	First Edition
2010.12	Second Edition <ul style="list-style-type: none"> • Safety Guide added • Order of sections changed • Appendix : Examples updated for [Power Supply Unit PS241 - PS242 and Number of Connectable Controllers]
2017.04	Third Edition <ul style="list-style-type: none"> • Appendix 1: Controller type added in [Power Supply Unit PS241/PS242 and Number of Connectable Controllers]
2017.11	3B Edition <ul style="list-style-type: none"> • Appendix 1: Power current revised for PCON Controllers
2018.03	Fourth Edition <ul style="list-style-type: none"> • 4. Basic Specifications : Change made to specification names • Appendix 1: Models added, descriptions for supply current revised, note added • Appendix 2: Changed method of determining the number of connected units to describe with rated output with and without output
2018.08	4B Edition <ul style="list-style-type: none"> • Caution note added in Precautions in Handling and in 10. Parallel Operation : Caution in Parallel Operation
2025.11	4C Edition <ul style="list-style-type: none"> • Changes due to discontinuation of including the Instruction Manual DVD • Changes due to discontinuation of including the First Step Guide



IAI Corporation

Head Office: 1210 Ihara Shimizu-KU Shizuoka City Shizuoka 424-0114, Japan
TEL +81-54-364-5105 FAX +81-54-364-2589
website: www.iai-robot.co.jp/

IAI America, Inc.

Head Office: 2690 W. 237th Street, Torrance, CA 90505
TEL +1-310-891-6015 FAX +1-310-891-0815
Chicago Office: 110 East State Parkway, Schaumburg, IL 60173
TEL +1-847-908-1400 FAX +1-847-908-1399
Atlanta Office: 1220 Kennestone Circle, Suite 108, Marietta, GA 30066
TEL +1-678-354-9470 FAX +1-678-354-9471
website: www.intelligentactuator.com

Technical Support available in Europe

IAI Industrieroboter GmbH

Ober der Röth 4, D-65824 Schwalbach am Taunus, Germany
TEL +49(0)6196-88950 FAX +49(0)6196-889524
website: www.iai-automation.com

Technical Support available in Great Britain



Duttons Way, Shadsworth Business Park, Blackburn, Lancashire, BB1 2QR, United Kingdom
TEL +44(0)1254-685900
website: www.lcautomation.com

IAI (Shanghai) Co., Ltd.

SHANGHAI JIAHUA BUSINESS CENTER A8-303, 808, Hongqiao Rd. Shanghai 200030, China
TEL+86-21-6448-4753 FAX +86-21-6448-3992
website: www.iai-robot.com

IAI Robot (Thailand) Co., Ltd.

825 PhairojKijja Tower 7th Floor, Debaratana RD., Bangna-Nuea, Bangna, Bangkok 10260, Thailand
TEL +66-2-361-4458 FAX +66-2-361-4456
website: www.iai-robot.co.th