

**Light Position Controller for RCS2/RCS3/
Single-axis Robot/Cartesian Robot**

SCON-CAL



The small SCON-CAL controller is the newest addition to the SCON series. The compact controller saves you installation space.

SCON

1 Smaller

- The SCON-CAL measures only 49 mm wide, 158 mm high and 116 mm deep, making it substantially smaller than the SCON-CA.

34% smaller in volume

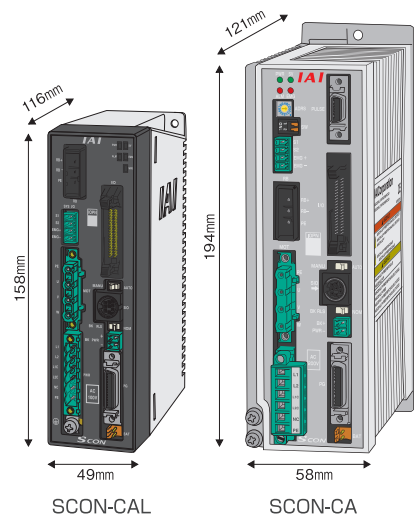

- Multiple SCON-CALs can be installed without leaving any space in between, which helps reduce the installation space for your control panel.

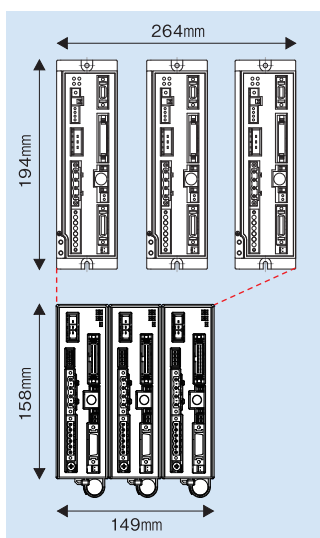

Installing three SCON-CAs

Installation space: Approx. 53% less
Installation width: Approx. 43% less

Installing three SCON-CALs

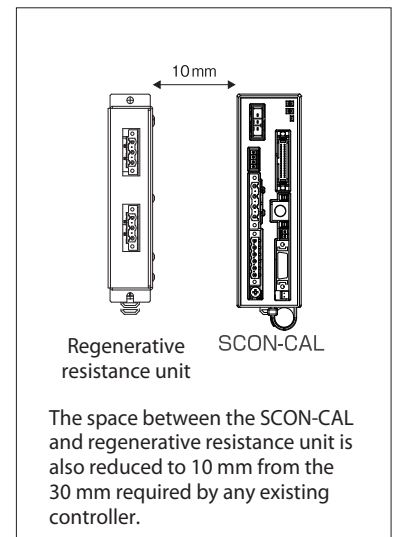

The smaller controller reduces the size of your control panel.

2 Easier to Maintain

- When the absolute battery voltage or fan speed drops, the “WRG (warning)” LED turns on to alert the situation. With this function, you are informed visually when to replace each maintenance part. (The controller can also be set up to output a warning signal.)



- The total number of actuator movements and the total distance travelled are calculated and recorded in the controller, and when the predetermined count or distance is exceeded, a signal is output to an external device. You can use this function to check when the actuator needs re-greasing or periodic inspection. Past alarms are displayed to facilitate the analysis of the alarms because the time and date of each alarm that has occurred is now shown on the alarm history screen.

3 Supporting Various Field Networks

CC-Link, DeviceNet, PROFIBUS-DP, CompoNet, EtherCAT, EtherNet/IP, PROFINET IO are supported.



4 Safety Category Compliant

All you need is to provide a proper external circuit, and your equipment will meet the requirements for Safety Categories 1 to 4.

5 Mountable on DIN Rails

The DIN rail mounting specification is available as an option.

6 Differences among SCON-CA/SCON-CAL/MSCON

[Function Comparison Table]

	SCON-CA	SCON-CAL	MSCON
Supported encoders	Incremental Absolute	Incremental Absolute	Incremental Absolute
Pulse train control	○	—	—
Servo monitor function (*1)	○	—	○
Offboard tuning (*2)	○	△ Servo monitor analysis not supported.	○
Vibration control function (*3)	○	△ Servo monitor analysis not supported.	○
Axis address setting method	Rotary switch	Parameter	Fixed
Global support	—	○	—
Number of connectable axes	1 axis	1 axis	1 to 6 axes
Supported motor wattages	12W/20W/30W 60W/100W motor 150W/200W motor	○	○
	400W/600W/750W motor	○	—
	LSA-S10H/N15, N19, LSAS-N15 and LSA-N10/LSAS-N10	○	—
	750W actuator motor with load cell	○	—

<<Explanation of Functions>>

(*1) Servo monitor function: You can check the current speed, position, etc.

(*2) Offboard tuning: An optimal servo gain is calculated according to the load.

(*3) Vibration control function: When the actuator slider moves, oscillation (vibration) of the work installed on the slider is suppressed.

SCON-CAL Controller

List of Models

Model	SCON-CAL / CGAL								
External view									
I/O type (*1)	Standard specification		Network connection specification (optional) (*2)						
I/O type specification	PIO connection specification		DeviceNet	CC-Link	PROFIBUS-DP	CompoNet	EtherCAT	EtherNet/IP	PROFINET IO
I/O type code	NP/PN		DV	CC	PR	CN	EC	EP	PRT
Applicable encoder type	Incremental	Absolute	Incremental/Absolute						

(*1) This product does not support pulse train control. (*2) If a network specification is selected, PIOs are not available.

Model

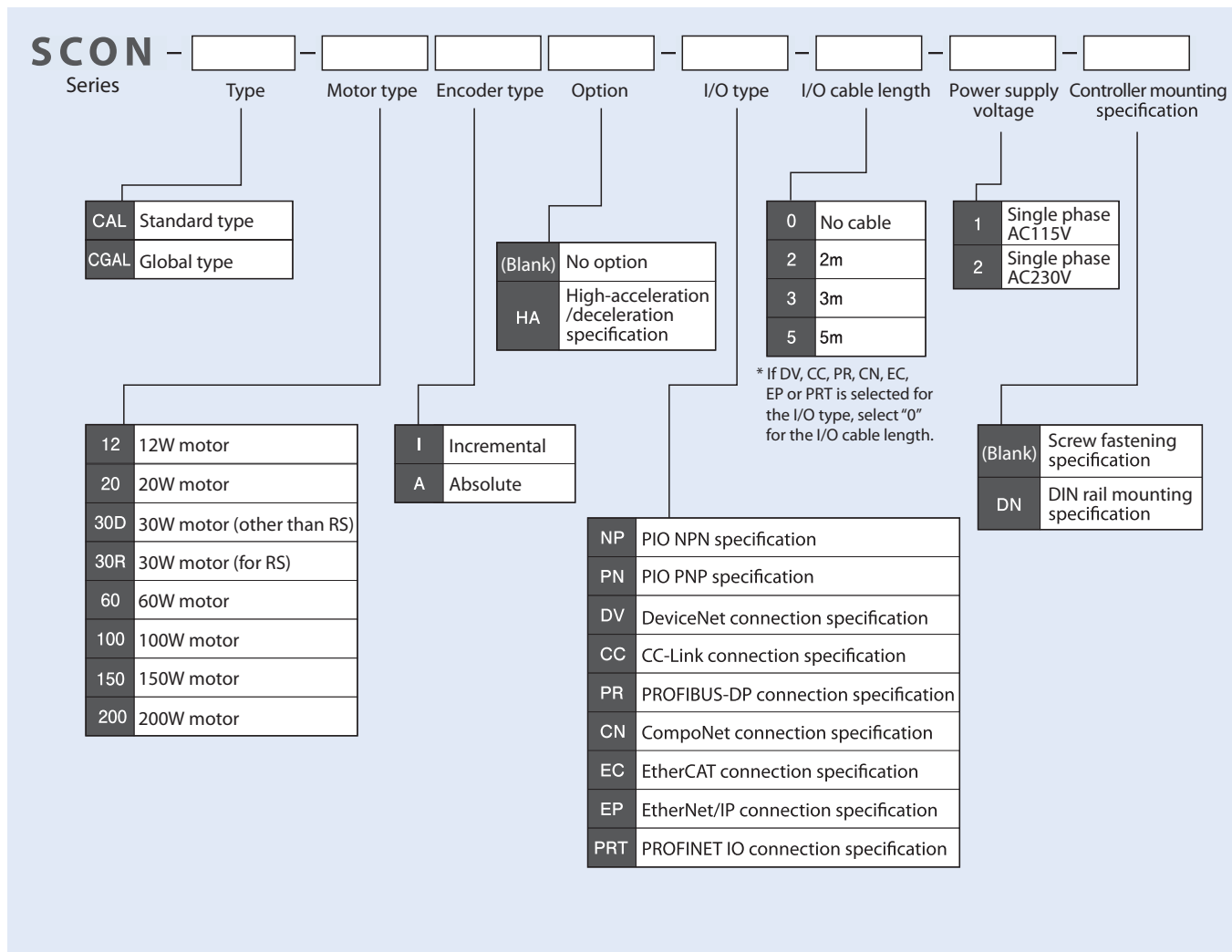

System Configuration

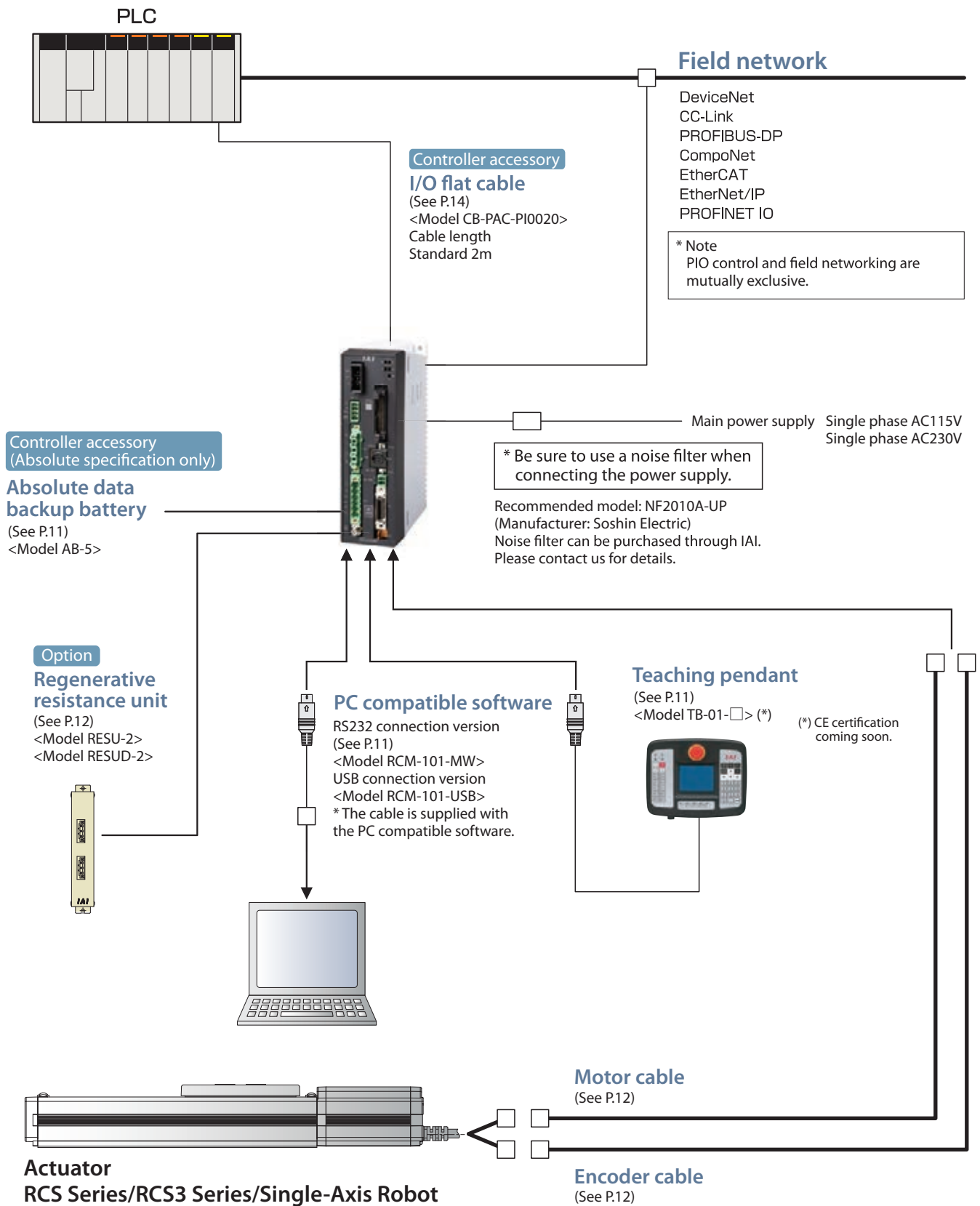

***The actuators which cannot be connected to SCON-CAL**

- Actuators which motor wattage is greater than 200 W
- Linear motors
- Incremental types of the following models:
 - + NS-S types + RCS2-SRA7BD, SRGD7BD, SRGS7BD
 - + Mini RoboCylinder RCS2-RN5N, RP5N, G55N, GD5N, SD5N, TCA5N, TWA5N, TFA5N

Operation Modes

This controller only supports the positioner control mode.

In the positioner mode, you can enter position data (target position, speed, acceleration, etc.) in the controller under the desired numbers and then specify each number externally via a I/O (input/output signal) to operate the actuator. Also, in the positioner mode, you can select the desired operation mode from the six modes using the parameter.

Mode	Number of positioning points	Features
Positioner mode	Positioning mode	64 points Standard factory-set mode. Specify externally a number corresponding to the position you want to move to, to operate the actuator.
	Teaching mode	64 points In this mode, you can move the slider (rod) via an external signal and register the stopped position in the position data table.
	256-point mode	256 points In this mode, the number of positioning points available in the positioning mode has been increased to 256 points.
	512-point mode	512 points In this mode, the number of positioning points available in the positioning mode has been increased to 512 points.
	Solenoid valve mode 1	7 points In this mode, the actuator can be moved only by turning signals ON/OFF, just like you do with an air cylinder of solenoid valve type.
	Solenoid valve mode 2	3 points In this mode, the output signal is set to the same as the air cylinder auto switch in the solenoid valve mode.

I/O Signal Table * You can select one of six types of I/O signal assignments.

Pin No.	Category	Positioning point	Parameter (PIO pattern) selection					
			0	1	2	3	4	5
			Positioning mode 64 points	Teaching mode 64 points	256-point mode 256 points	512-point mode 512 points	Solenoid valve mode 1 7 points	Solenoid valve mode 2 3 points
1A	24V		P24					
2A	24V		P24					
3A	—		NC					
4A	—		NC					
5A	Input	IN0	PC1	PC1	PC1	PC1	ST0	ST0
6A		IN1	PC2	PC2	PC2	PC2	ST1	ST1 (JOG+)
7A		IN2	PC4	PC4	PC4	PC4	ST2	ST2(-)
8A		IN3	PC8	PC8	PC8	PC8	ST3	—
9A		IN4	PC16	PC16	PC16	PC16	ST4	—
10A		IN5	PC32	PC32	PC32	PC32	ST5	—
11A		IN6	—	MODE	PC64	PC64	ST6	—
12A		IN7	—	JISL	PC128	PC128	—	—
13A		IN8	—	JOG+	—	PC256	—	—
14A		IN9	BKRL	JOG-	BKRL	BKRL	BKRL	BKRL
15A		IN10	RMOD	RMOD	RMOD	RMOD	RMOD	RMOD
16A		IN11	HOME	HOME	HOME	HOME	HOME	—
17A		IN12	*STP	*STP	*STP	*STP	*STP	—
18A		IN13	CSTR	CSTR/PWRT	CSTR	CSTR	—	—
19A		IN14	RES	RES	RES	RES	RES	RES
20A	IN15	SON	SON	SON	SON	SON	SON	
1B	Output	OUT0	PM1	PM1	PM1	PM1	PE0	LSO
2B		OUT1	PM2	PM2	PM2	PM2	PE1	LS1 (TRQS)
3B		OUT2	PM4	PM4	PM4	PM4	PE2	LS2(-)
4B		OUT3	PM8	PM8	PM8	PM8	PE3	—
5B		OUT4	PM16	PM16	PM16	PM16	PE4	—
6B		OUT5	PM32	PM32	PM32	PM32	PE5	—
7B		OUT6	MOVE	MOVE	PM64	PM64	PE6	—
8B		OUT7	ZONE1	MODES	PM128	PM128	ZONE1	ZONE1
9B		OUT8	PZONE/ZONE2	PZONE/ZONE1	PZONE/ZONE1	PM256	PZONE/ZONE2	PZONE/ZONE2
10B		OUT9	RMDS	RMDS	RMDS	RMDS	RMDS	RMDS
11B		OUT10	HEND	HEND	HEND	HEND	HEND	HEND
12B		OUT11	PEND	PEND/WEND	PEND	PEND	PEND	—
13B		OUT12	SV	SV	SV	SV	SV	SV
14B		OUT13	*EMGS	*EMGS	*EMGS	*EMGS	*EMGS	*EMGS
15B		OUT14	*ALM	*ALM	*ALM	*ALM	*ALM	*ALM
16B	OUT15	*BALM	*BALM	*BALM	*BALM	*BALM	*BALM	
17B	—		NC					
18B	—		NC					
19B	OV		N					
20B	OV		N					

* In the above table, signals in () represent functions available before the home return.

* In the above table, signals preceded by * are negative logic signals. Negative logic input signals are processed when turned OFF. Negative logic output signals normally remain ON while the power is supplied, and turn OFF when the signal is output.

Explanation of the I/O Signal Functions

The table below explains the functions assigned to the controller's I/O signals.
The available signals vary depending on the settings. Check the available functions.

Category	Signal abbreviation	Signal name	Description of function
Input	CSTR	PTP strobe (start signal)	The actuator starts moving to the position set by the command position.
	PC1~PC256	Command position number	The position number of the target position is input (binary input).
	BKRL	Forced brake release	The brake is forcibly released.
	RMOD	Operation mode switching	The operation mode can be switched when the MODE switch on the controller is in the AUTO position. (The switch position is AUTO when this signal is OFF, or MANU when the signal is ON.)
	*STP	Pause	The actuator will decelerate to a stop when this signal turns OFF while the actuator is moving. The remaining movement will be suspended while the actuator is stopped and the movement will resume once the signal turns ON.
	RES	Reset	The alarm will be reset when the signal turns ON. The remaining travel can be cancelled by turning this signal ON while the actuator is paused (*STP is OFF).
	SON	Servo ON	The servo is ON while this signal is ON, and remains OFF while this signal is OFF.
	HOME	Home return	When this signal turns ON, the actuator performs home return operation.
	MODE	Teaching mode	When this signal turns ON, the actuator switches to the teaching mode. (Switching will not occur if CSTR, JOG+ and JOG- are all ON and the actuator is still moving.)
	JISL	Jog/inch switching	When this signal turns OFF, the actuator can be jogged with JOG+ and JOG-. When the signal is ON, the actuator can be inched with JOG+ and JOG-.
	JOG+, JOG-	Jog	When the JISL signal turns OFF, the actuator can be jogged in the positive direction when the ON edge of the JOG+ signal is detected, or in the negative direction when the ON edge of the JOG- signal is detected. If the OFF edge is detected while the actuator is jogging with each signal, the actuator will decelerate to a stop. When the JISL signal turns ON, the actuator can be inched.
	PWRT	Current position write	In the teaching mode, specify a position and then turn this signal ON for at least 20ms, and the current position will be written to the specified position.
	ST0~ST6	Start signal	In the solenoid valve mode, the actuator moves to the specified position when this signal turns ON. (The start signal is not required.)
Output	PEND	Positioning complete	This signal turns ON when the actuator enters the in-position band after movement. Even if the actuator exceeds the in-position band, the PEND signal does not turn OFF, but the INP signal turns OFF. PEND and INP can be switched using a parameter.
	PM1~PM256	Complete position number	The position number of the position reached at the end of positioning is output (binary output).
	HEND	Home return completion	This signal turns ON upon completion of home return.
	ZONE1, ZONE2	Zone	This signal turns ON if the current actuator position is within the range set by the parameter.
	PZONE	Position zone	This signal turns ON when the current actuator position enters the range set in the position data table after position movement. This signal can be used with ZONE1/ ZONE2, but PZONE becomes effective only when moving to a specified position.
	RMDS	Operation mode status output	The operation mode status is output. This signal turns ON when the controller is in the manual mode.
	*ALM	Alarm	This signal is ON when the controller is in a normal condition, and turns OFF when an alarm occurs.
	ALM1~ALM8	Alarm code output signal	When an alarm occurs, a detail of the alarm is output as a binary code.
	MOVE	Moving	This signal is ON while the actuator is moving (also during home return and push-motion operation).
	SV	Servo ON	This signal is ON while the servo is ON.
	*EMGS	Emergency stop output	This signal is ON when no emergency stop is actuated on the controller, and turns OFF when an emergency stop is actuated.
	*BALM	Absolute battery voltage low warning	This signal turns OFF to provide a warning when the absolute battery voltage drops, fan speed drops or overloading occurs. (The actuator continues to operate.)
	MODES	Teaching mode output	This signal turns ON when the actuator enters the teaching mode via MODE signal input. It turns OFF once the actuator returns to the normal mode.
	WEND	Write complete	This signal is OFF immediately after switching to the teaching mode, and turns ON once writing is completed according to the PWRT signal. When the PWRT signal turns OFF, this signal also turns OFF.
	PE0~PE6	Current position number	This signal turns ON when the actuator has completed moving to the target position in the solenoid valve mode.
LS0~LS2	Limit switch output	This signal turns ON when the current actuator position enters the in-position band set before and after the target position. If the home return has already completed, this signal is output even before a movement command is issued or while the servo is OFF.	

* In the above table, signals preceded by * are negative logic signals, which are normally ON while the power is supplied, and turn OFF when the signal is output.

I/O Wiring Diagram

Positioning mode/Teaching mode/Solenoid valve mode

PIO connector (NPN specification)

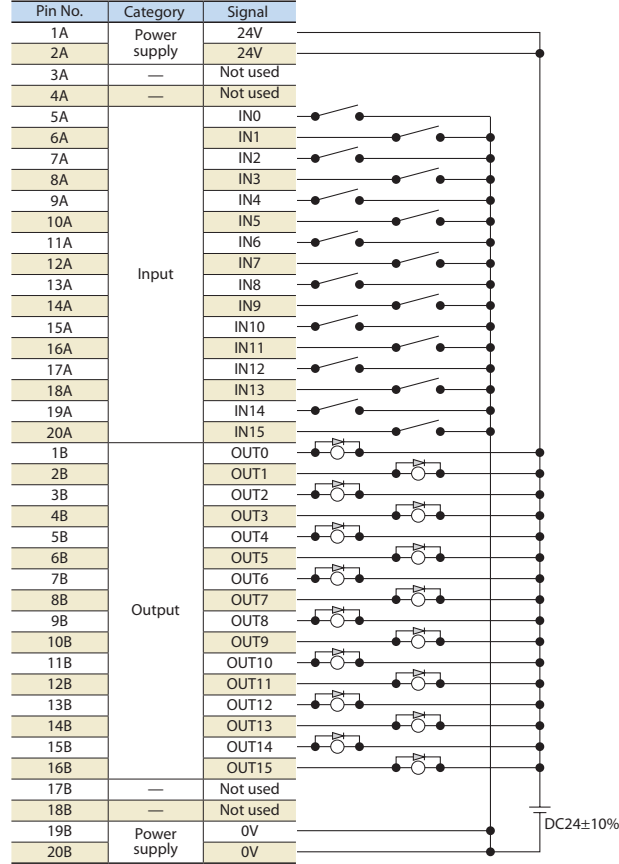

*Connect Pins 1A and 2A to 24V, and Pins 19B and 20B to 0V.

I/O Specification

Input Part External Input Specifications

Item	Specification
Input voltage	DC24V ±10%
Input current	4mA/1 circuit
ON/OFF voltage	ON voltage: DC18V min. OFF voltage: DC6V max.
Isolation method	Photocoupler

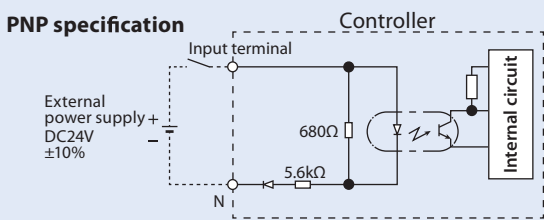
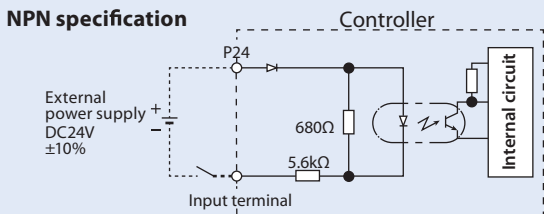

Output Part External Output Specifications

Item	Specification
Load voltage	DC24V
Maximum load current	50mA/1 point, 400mA/8 points
Leak current	0.1mA max./1 point
Isolation method	Photocoupler

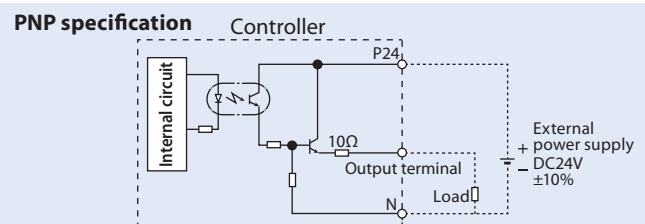
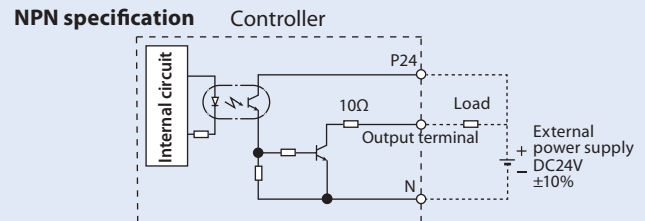

Specification Table

Item		Specification
Applicable motor capacity		200W or less
Connected actuator		RCS2/RCS3 series actuator/single-axis robot
Number of controlled axes		1 axis
Operation method	Positioner	○
	Direct value	○ (Available only for the Fieldbus specification)
	Pulse train	—
Number of positioning points		512 points (PIO specification), 768 points (Fieldbus specification)
Backup memory		Nonvolatile memory (FRAM)
I/O connector		40-pin connector
Number of I/O points		16 input points/16 output points (Not available for the Fieldbus specification)
I/O power supply		Externally supplied 24VDC±10%
Serial communication		RS485 1ch
Peripherals communication cable		CB-PAC-PIO □□□
Position detection method		Incremental encoder/absolute encoder
Emergency stop function		Standard type (CAL): Available (Built-in cutoff relay) Global type (CGAL): Not available (External cutoff relay)
Forced electromagnetic brake release		Brake release switch ON/OFF
Input power supply		Single-phase AC100V to AC115V ±10% Single-phase AC200V to AC230V ±10%
Power-supply capacity		12W/89VA 20W/74VA 30W (other than RS)/94VA 30W (RS)/186VA 60W/186VA 100W/282VA 150W/376VA 200W/469VA
Vibration resistance		XYZ directions – 10 to 57Hz: Single amplitude 0.035mm (continuous), 0.075mm (intermittent) 58 to 150Hz: 4.9 m/s ² (continuous), 9.8 m/s ² (intermittent)
Calendar/ Clock function	Retention time	Approx. 10 days
	Charge time	Approx. 100 hours
Protective functions		Overcurrent, abnormal temperature, low fan speed monitor, encoder disconnection, etc.
Operating temperature range		0 ~ 40℃
Operating humidity range		85%RH or less (non-condensing)
Operating ambience		Not exposed to corrosive gases
Installation	Installation direction	Vertical installation (Exhaust side on top)
	Installation method	Screw mounting or DIN rail mounting
Air cooling method		Forced air cooling
Protection degree		IP20 or equivalent
Mass		Approx. 560g (+ 25g for the absolute specification)
External dimensions		49 mm (W) x 158 mm (H) x 116 mm (D)

External Dimensions

Screw Mounting Specification

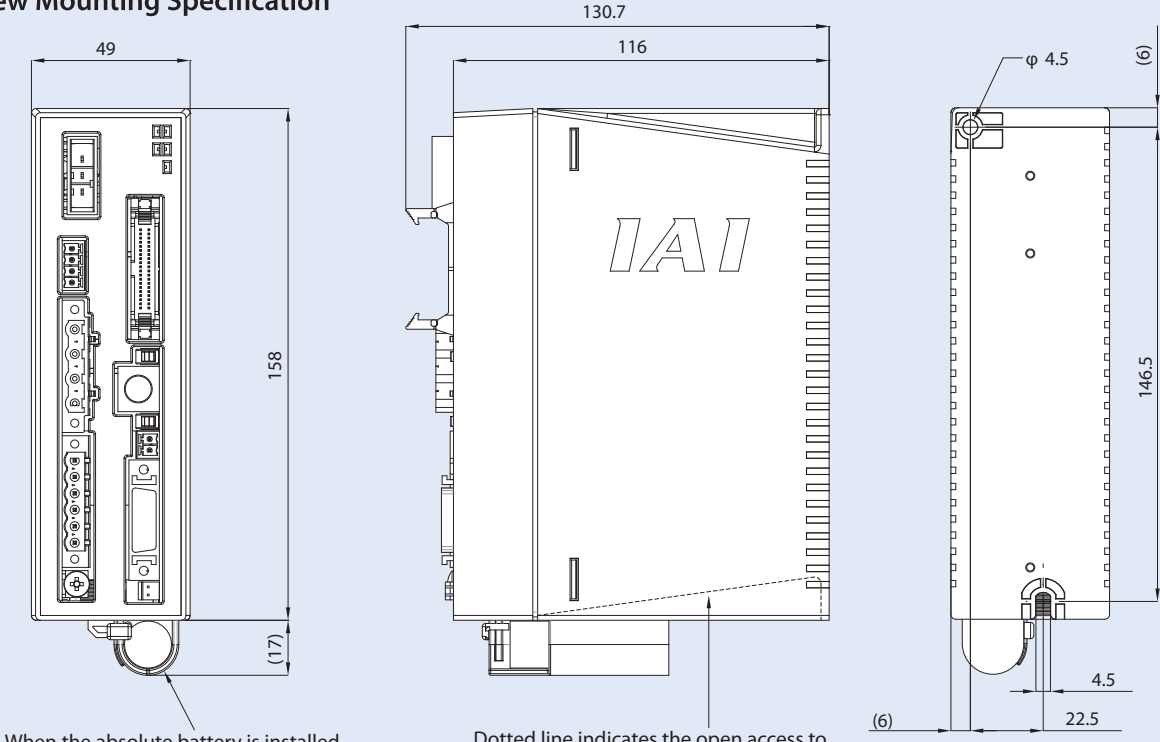

When the absolute battery is installed (Absolute encoder specification)

Dotted line indicates the open access to the screw mount. The controller can be mounted with a screw driver without removing the cover.

DIN Rail Mounting Specification

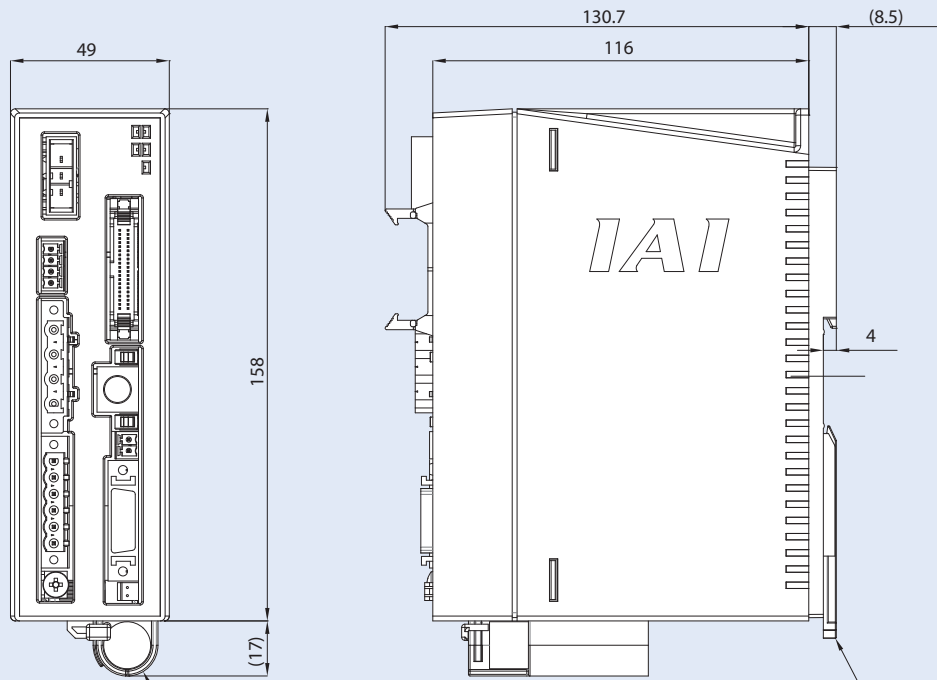

When the absolute battery is installed (Absolute encoder specification)

DIN rail mounting specification

Name of Each Part

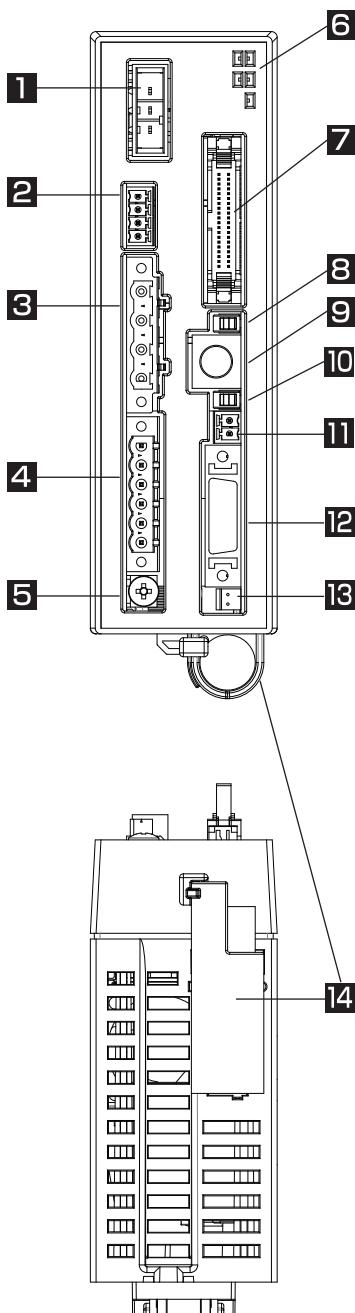

1 Regenerative resistance unit connector
Connector for the resistance unit that absorbs regeneration current produced when the actuator decelerates to stop.

2 System I/O connector
Connector for the emergency stop switch, etc.

3 Motor connector
Connector for the motor cable of the actuator

4 Power supply connector
AC power connector. Divided into the control power input and motor power input.

5 Grounding screw
Protective grounding screw. Always ground this screw.

6 LED display
These LED colors indicate the condition of the controller.

Name	Color	Explanation
PWR	Green	Lits when the system is ready (after power is ON, CPU normal function)
SV	Green	Lits when servo is ON
ALM	Orange	Lits during an alarm
EMG	Red	Lits during an emergency stop
WRG	Orange	Flashes when ABS battery voltage is low or a rotational speed of the fan decreases, etc.

7 PIO connector
Connector for the cable connecting input/output signals to the peripheral equipments of PLC, etc.

8 Operating mode switch

Name	Explanation
MANU	Does not receive PIO commands
AUTO	Can receive PIO commands

*For a standard specification, the emergency stop switch on the teaching pendant becomes effective when the line is connected, regardless of whether this switch is set to AUTO or MANU.

9 SIO connector
Connector for the teaching pendant or PC communications cable.

10 Brake release switch
This is the electromagnetic brake forced release switch, integrated with the actuator.
*It is necessary to connect the DC24V power for the brake drive.

11 Brake power connector
Brake power DC 24V supply connector (only required when the brake equipped actuator is connected)

12 Encoder connector
Connector for the encoder

13 Absolute battery connector
Connector for the absolute data backup battery. (Required only for absolute encoder specifications)

14 Absolute battery holder
Battery holder for installing the absolute data backup battery

SCON-CAL Controller

Options

Teaching Pendant

- Features Teaching device offering position input, test operation, monitoring and other functions.

- Model **TB-01-C-ENG (*)** (*) CE certification coming soon.

- Configuration

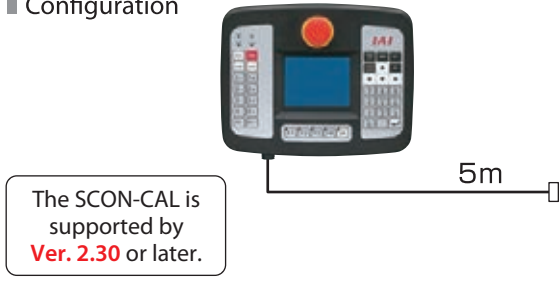

Dummy Plug

- Features This plug is needed when the actuator is operated with a safety category compliant controller (SCON-CGAL).

- Model **DP-5**



PC Compatible Software (Windows Only)

- Features This startup support software provides functions to input positions, perform test operations and monitor data, among others. Incorporating all functions needed to make adjustments, this software helps shorten the initial startup time.

- Model **RCM-101-MW-ENG** (External device communication cable + RS232 conversion unit included)

The SCON-CAL is supported by **Ver. 9.07.00.00** or later.

- Configuration

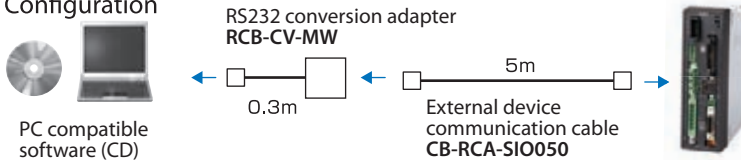

- Model **RCM-101-USB-ENG** (External device communication cable + USB conversion adapter + USB cable included)

The SCON-CAL is supported by **Ver. 9.07.00.00** or later.

- Configuration

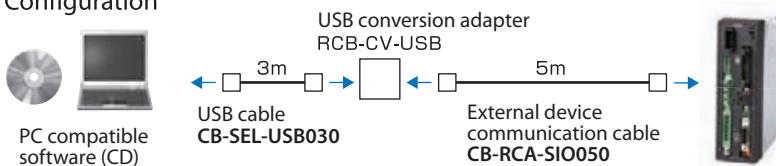

Absolute Data Backup Battery

- Features Absolute data backup battery used when an actuator of absolute specification is operated.

- Model **AB-5** (Battery only) **AB-5-CS3** (With case)



Regenerative Resistance Unit

■ **Features** This unit converts regenerative current that generates when the motor decelerates, to heat. Check the total wattage of the actuators to be operated and provide a regenerative resistance unit or units if required.

■ **Model RESU-2** (Standard specification)
RESUD-2 (DIN rail mounting specification)

■ **Specification**

Model	RESU-2	RESUD-2
Unit mass	Approx. 0.4 kg	
Built-in regenerative resistor	235Ω 80W	
Actuator mounting method	Screw mounting	DIN rail mounting
Supplied cable	CB-SC-REU010	

■ **External Dimensions**

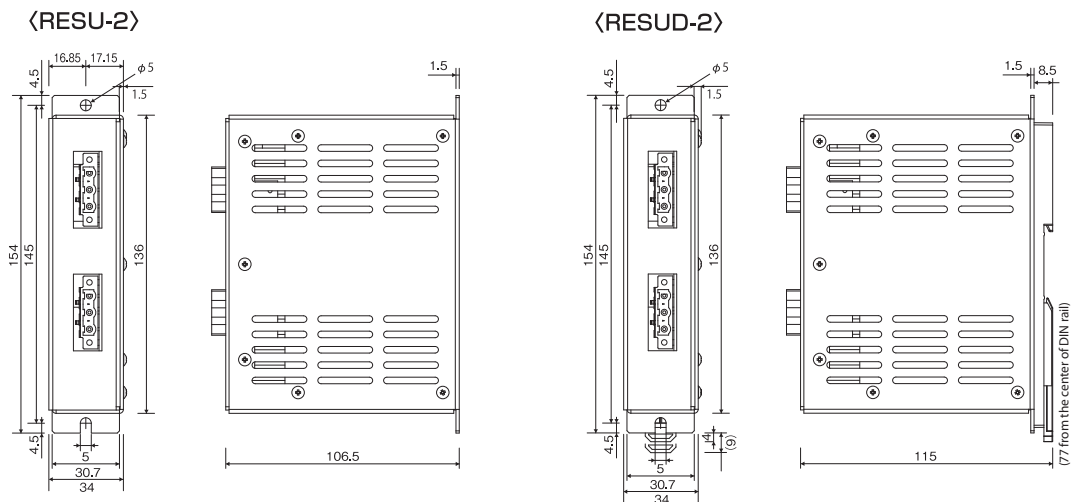

■ **Guide for Required Quantity**

	Horizontal	Vertical
0 unit	~100W	
1 unit	~200W	

* The required regenerative resistance may be more than as specified above depending on the operating conditions.

Replacement Fan Unit

■ **Model SCON-FU**

[Maintenance Cables]

Connected actuator		Motor cable		Encoder cable	
		Standard cable	Robot cable	Standard cable	Robot cable
RCS3 RCS2 RCS3CR RCS2CR RCS2W	RTC□L RT6	CB-RCC-MA□□□□ see P13	CB-RCC-MA□□□□-RB CB-XEU-MA□□□□ see P13	CB-RCS2-PLA□□□□ see P14	CB-X2-PLA□□□□ CB-XEU2-PLA□□□□ see P14
	Other models			CB-RCS2-PA□□□□ see P13	CB-X3-PA□□□□ CB-XEU3-PA□□□□ see P13
Other models	NS w/o LS	CB-X-MA□□□□ CB-XEU-MA□□□□ see P13		CB-X3-PA□□□□	CB-XEU3-PA□□□□ see P13
	NS w/ LS			CB-X2-PLA□□□□	CB-XEU2-PLA□□□□ see P14
	Model other than NS w/o LS			CB-X1-PA□□□□	CB-XEU1-PA□□□□ see P13
	Model other than NS w/ LS			CB-X1-PLA□□□□	CB-XEU1-PLA□□□□ see Back Page
	ISWA			CB-X1-PA□□□□-WC	see Back Page

* All actuators other than the RCS3/RCS2 series come standard with a robot cable.

SCON-CAL Controller

Maintenance Parts

Please refer to the models listed below if a cable needs to be exchanged, etc., after your purchase.

Model number	CB-RCC-MA □□□	Motor cable	for RCS2 / RCS3
	CB-RCC-MA □□□-RB	Motor robot cable	
	CB-X-MA □□□	Motor robot cable	for models other than RCS2 / RCS3
	CB-XEU-MA □□□	EU motor robot cable	for RCS2 / RCS3 and other models

* Enter the cable length (L) into □□□. Compatible to a Maximum of 30 meters.
Ex.: 080 = 8m

(Fig.: Motor cable CB-RCC-MA□□□ / CB-RCC-MA□□□-RB / CB-X-MA□□□ with plastic connector)

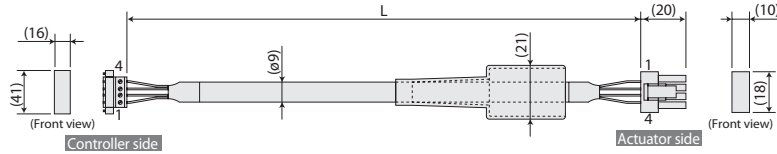

Minimum bending R: r = 51 mm or more (for movable use)
* If the cable must be guided in a cable track, use a robot cable.

Wire	Color	Signal	No.	No.	Signal	Color	Wire
0.75sq	Green	PE	1	1	U	Red	0.75sq (crimped)
	Red	U	2	2	V	White	
	White	V	3	3	W	Black	
	Black	W	4	4	PE	Green	

(Fig.: EU motor robot cable CB-XEU-MA□□□, EU version with M18 plastic round connector)

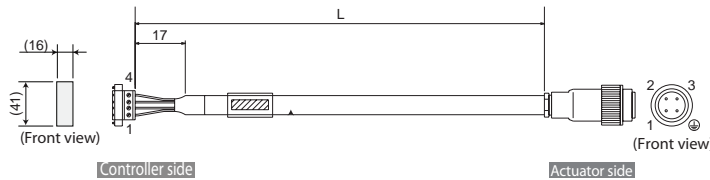

Minimum bending R: r = 51 mm or more (for movable use)
* Only robot cable is available for this model

Wire	Color	Signal	No.	No.	Signal	Color	Wire
0.75sq	Green/yellow	PE	1	⊕	PE	Green/yellow	0.75sq (crimped)
	Black/white*1	U	2	1	U	Black/white*1	
	Black/white*2	V	3	2	V	Black/white*2	
	Black/white*3	W	4	3	W	Black/white*3	

Model number	CB-RCS2-PA □□□	Encoder cable	for RCS2 / RCS3
	CB-X3-PA □□□	Encoder robot cable	
	CB-XEU3-PA □□□	EU encoder robot cable	for NS / RCS2 / RCS3

* Enter the cable length (L) into □□□. Compatible to a Maximum of 30 meters.
Ex.: 080 = 8m

(Fig.: Encoder cable CB-RCS2-PA□□□ / CB-X3-PA□□□ with plastic connector)

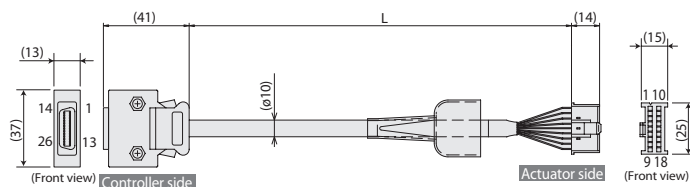

Minimum bending R: r = 58 mm or more (for movable use)
* If the cable must be guided in a cable track, use a robot cable.

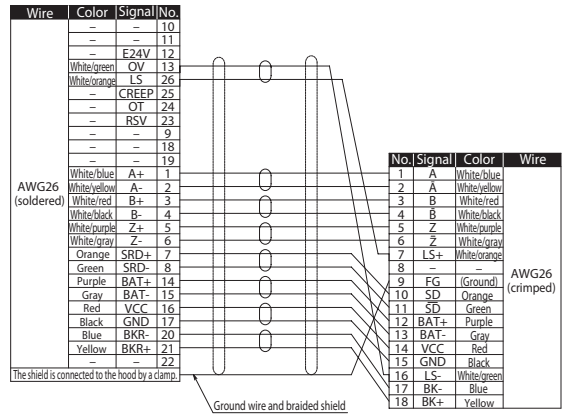

(Fig.: EU encoder robot cable CB-XEU3-PA□□□, EU version with metal connector)

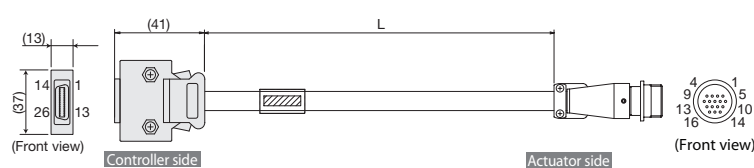

Minimum bending R: r = 58 mm or more (for movable use)

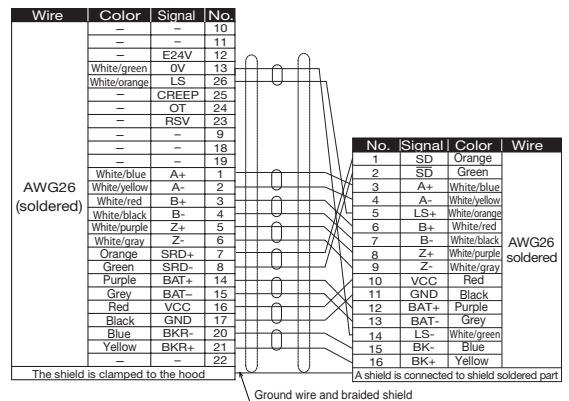

Model number	CB-RCS2-PLA □ □ □ □	Limit switch encoder cable	for RCS2 Rotary type
	CB-X2-PLA □ □ □ □	Limit switch encoder robot cable	for LS specification models
	CB-XEU2-PLA □ □ □ □	EU limit switch encoder robot cable	NS / RCS2 Rotary type

* Enter the cable length (L) into □ □ □. Compatible to a Maximum of 30 meters.
 Ex.: 080 = 8m

(Fig.: LS encoder cable CB-RCS2-PLA □ □ □ □ / CB-X2-PLA □ □ □ □ with plastic connector)

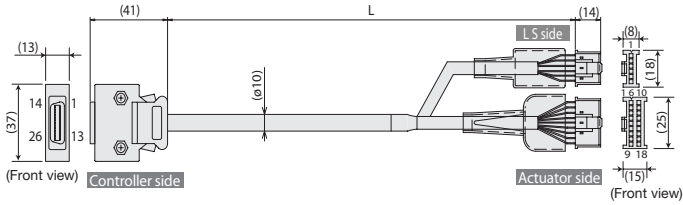

Minimum bending R: r = 58 mm or more (for movable use)

* If the cable must be guided in a cable track, use a robot cable.

Wire	Color Stand Cable	Color Robot Cable	Signal	No.	No.	Signal	Color Stand Cable	Color Robot Cable	Wire
-	-	-	-	10	1	E24V	White/orange	Brown/white	AWG26 (crimped)
-	-	-	-	11	2	0V	White/green	Gray/white	
Brown/white	White/orange	E24V	12	3	LS	Brown/blue	Red/white		
Gray/white	White/green	0V	13	4	CREEP	Brown/yellow	Black/white		
Brown/blue	White/green	LS	26	5	OT	Brown/red	Yellow/black		
Red/white	Brown/yellow	CREEP	25	6	RSV	Brown/black	Pink/black		
Yellow/black	Brown/red	OT	24	-	-	-	-	AWG26 (crimped)	
Pink/black	Brown/black	RSV	23	7	SRD+	Orange	Blue		
-	-	-	-	8	SD	Orange	Blue		
-	-	-	-	9	SD	Orange	Blue		
-	-	-	-	18	-	-	-		
-	-	-	-	19	-	-	-		
Pink	White/blue	A+	1	2	A+	White/blue	Pink		
Purple	White/yellow	A-	2	3	A-	White/yellow	Purple		
White	White/red	B+	3	4	A-	White/yellow	White		
Blue/red	White/black	B-	4	5	-	-	-		
Orange/white	White/purple	Z+	5	6	B+	White/red	White/black		
Green/white	White/gray	Z-	6	7	B-	White/black	White/red		
Blue	Orange	SRD+	7	8	Z+	White/gray	Green/white		
Orange	Green	SRD-	8	9	Z-	White/gray	Orange/white		
Black	Purple	BAT+	14	10	VCC	Red	Red		
Blue/red	White/black	BAT-	15	11	GND	Black	Black		
Yellow	Gray	VCC	16	12	BAT+	Purple	Purple		
Green	Red	GND	17	13	BAT-	Gray	Gray		
Brown	Black	BKR-	20	14	-	-	-		
Gray	Blue	BKR+	21	15	BK-	Blue	Blue		
Red	Yellow	BKR+	21	16	BK+	Yellow	Yellow		
-	-	-	22	-	-	-	-		

(*Brown/white" in cable color indicates the colors of line/insulator.)

(Fig.: EU LS encoder robot cable CB-XEU2-PLA □ □ □ □, EU version with metal connector)

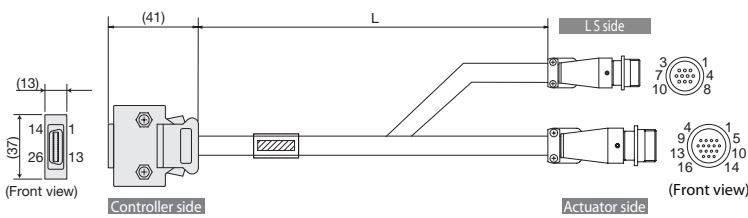

Minimum bending R: r = 58 mm or more (for movable use)

Wire	Color	Signal	No.	No.	Signal	Color	Wire
-	-	-	10	1	E24V	White/orange	AWG26 soldered
-	-	-	11	2	0V	White/green	
White/orange	E24V	12	3	LS	Brown/blue		
White/green	0V	13	4	CREEP	Brown/yellow		
Brown/blue	LS	26	5	OT	Brown/red		
Brown/yellow	CREEP	25	6	RSV	Brown/black		
Brown/red	OT	24	7	-	-		
Brown/black	RSV	23	8/9/10	-	-		
-	-	-	-	1	SD	Orange	AWG26 soldered
-	-	-	-	2	SD	Green	
White/blue	A+	1	3	A+	White/blue		
White/yellow	A-	2	4	A-	White/yellow		
White/red	B+	3	5	-	-		
White/black	B-	4	6	B+	White/red		
White/purple	Z+	5	7	B-	White/black		
White/gray	Z-	6	8	Z+	White/purple		
Orange	SRD+	7	9	Z-	White/gray		
Green	SRD-	8	10	VCC	Purple		
Purple	BAT+	14	11	GND	Black		
Gray	BAT-	15	12	BAT+	Purple		
Red	VCC	16	13	BAT-	Gray		
Black	GND	17	14	-	-		
Blue	BKR-	20	15	BK-	Blue		
Blue	BKR+	21	16	BK+	Yellow		
Yellow	BKR+	21	-	-	-		

(*White/orange" in cable color indicates the colors of line/insulator.)

Model number	CB-X1-PA □ □ □ □	Encoder robot cable	for models
	CB-XEU1-PA □ □ □ □	EU encoder robot cable	other than NS / RCS2 / RCS3

* Enter the cable length (L) into □ □ □. Compatible to a Maximum of 30 meters.
 Ex.: 080 = 8m

(Fig.: Encoder robot cable CB-X1-PA □ □ □ □ with plastic connector)

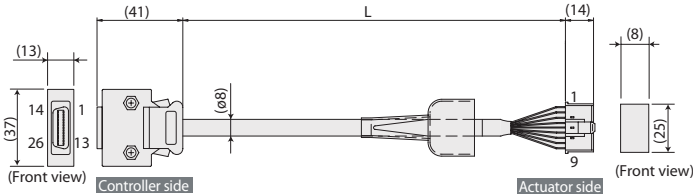

Minimum bend radius R: r = 44mm or larger (for movable use)

*Only robot cable is available for this model.

Wire	Color	Signal	No.	No.	Signal	Color	Wire
-	-	-	10	1	E24V	White/orange	AWG26 (crimped)
-	-	-	11	2	0V	White/green	
-	-	E24V	12	3	LS	Brown/blue	
-	-	0V	13	4	CREEP	Brown/yellow	
-	-	LS	26	5	OT	Brown/red	
-	-	CREEP	25	6	RSV	Brown/black	
-	-	OT	24	7	-	-	
-	-	RSV	23	8	-	-	
-	-	-	9	9	-	-	
-	-	-	18	-	-	-	
-	-	-	19	-	-	-	
-	-	-	-	1	A+	White/blue	AWG26 (crimped)
-	-	-	-	2	A-	White/yellow	
-	-	-	-	3	B+	White/red	
-	-	-	-	4	B-	White/black	
-	-	-	-	5	Z+	White/purple	
-	-	-	-	6	Z-	White/gray	
Orange	SRD+	7	7	VCC	Red		
Green	SRD-	8	8	GND	Black		
Purple	BAT+	14	9	BAT+	Purple		
Gray	BAT-	15	10	BAT-	Gray		
Red	VCC	16	11	-	-		
Black	GND	17	12	BK-	Blue		
Blue	BKR-	20	13	BK+	Yellow		
Blue	BKR+	21	14	-	-		
Yellow	BKR+	21	15	-	-		
-	-	-	22	-	-	-	

Wire	Color	Signal	No.	No.	Signal	Color	Wire
-	-	-	10	1	SD	Orange	AWG26 soldered
-	-	-	11	2	SD	Green	
-	-	E24V	12	3	-	-	
-	-	0V	13	4	-	-	
-	-	LS	26	5	-	-	
-	-	CREEP	25	6	-	-	
-	-	OT	24	7	-	-	
-	-	RSV	23	8	-	-	
-	-	-	9	9	-	-	
-	-	-	18	-	-	-	
-	-	-	19	-	-	-	
-	-	-	-	1	A+	White/blue	
-	-	-	-	2	A-	White/yellow	
-	-	-	-	3	B+	White/red	
-	-	-	-	4	B-	White/black	
-	-	-	-	5	Z+	White/purple	
-	-	-	-	6	Z-	White/gray	
Orange	SRD+	7	7	VCC	Red		
Green	SRD-	8	8	GND	Black		
Purple	BAT+	14	9	BAT+	Purple		
Gray	BAT-	15	10	BAT-	Gray		
Red	VCC	16	11	-	-		
Black	GND	17	12	BK-	Blue		
Blue	BKR-	20	13	BK+	Yellow		
Blue	BKR+	21	14	-	-		
Yellow	BKR+	21	15	-	-		
-	-	-	22	-	-	-	

Maintenance Parts

Model number **CB-X1-PLA**
CB-XEU1-PLA

Limit switch encoder robot cable
 EU limit switch encoder robot cable

for LS specification models
 other than NS / RCS2 / RCS3

* Enter the cable length (L) into . Compatible to a Maximum of 30 meters.
 Ex.: 080 = 8m

(Fig.: LS encoder robot cable CB-X1-PLA with plastic connector)

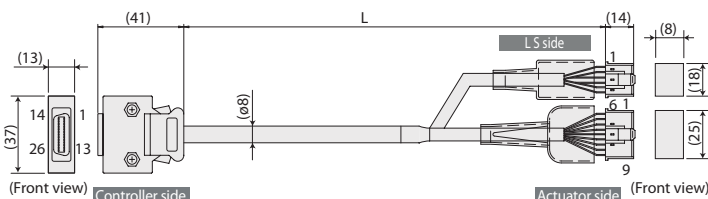

Minimum bend. radius R: r = 54mm or larger (for movable use)

*Only robot cable is available for this model.

(Fig.: EU LS encoder robot cable CB-XEU1-PLA , EU version with metal connector)

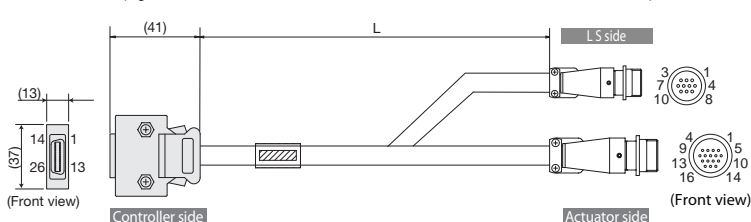

Minimum bend. radius R: r = 54mm or larger (for movable use)

*Only robot cable is available for this model.

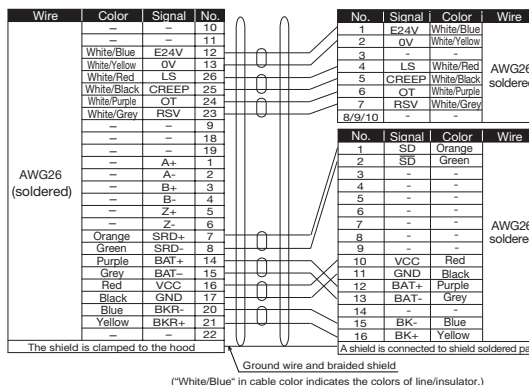
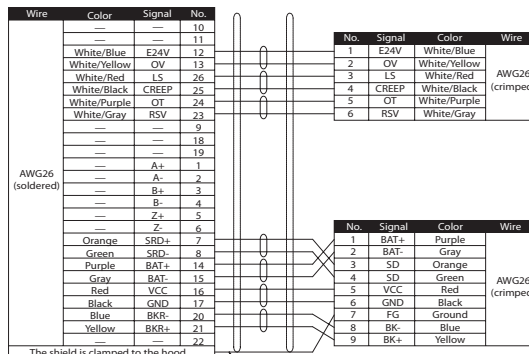

Model number **CB-X1-PA** -WC

Encoder robot cable

(Dedicated motor robot cable: CB-XEU-MA , see P. 13)

for splash-proof slider ISWA

* Enter the cable length (L) into . Compatible to a Maximum of 30 meters.
 Ex.: 080 = 8m

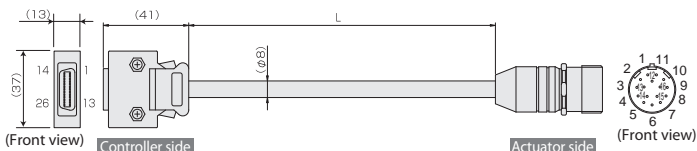

Minimum bend. radius R: r = 44mm or larger (for movable use)

*Only robot cable is available for this model.

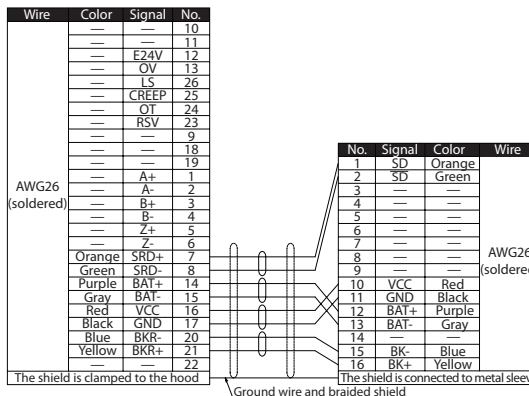

Model number **CB-PAC-PIO**

PIO Flat Cable

* Enter the cable length (L) into . Compatible to a Maximum of 10 meters.
 Ex.: 080 = 8m

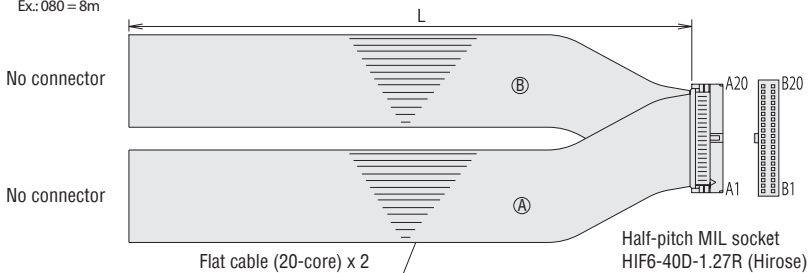

HIF6-40D-1.27R

No.	Signal name	Cable color	Wiring	No.	Signal name	Cable color	Wiring
A1	24V	Brown-1		B1	OUT0	Brown-3	
A2	24V	Red-1		B2	OUT1	Red-3	
A3		Orange-1		B3	OUT2	Orange-3	
A4		Yellow-1		B4	OUT3	Yellow-3	
A5	IN0	Green-1		B5	OUT4	Green-3	
A6	IN1	Blue-1		B6	OUT5	Blue-3	
A7	IN2	Purple-1		B7	OUT6	Purple-3	
A8	IN3	Gray-1		B8	OUT7	Gray-3	
A9	IN4	White-1		B9	OUT8	White-3	
A10	IN5	Black-1		B10	OUT9	Black-3	
A11	IN6	Brown-2		B11	OUT10	Brown-4	(pressure-welded)
A12	IN7	Red-2		B12	OUT11	Red-4	
A13	IN8	Orange-2		B13	OUT12	Orange-4	
A14	IN9	Yellow-2		B14	OUT13	Yellow-4	
A15	IN10	Green-2		B15	OUT14	Green-4	
A16	IN11	Blue-2		B16	OUT15	Blue-4	
A17	IN12	Purple-2		B17		Purple-4	
A18	IN13	Gray-2		B18		Gray-4	
A19	IN14	White-2		B19	0V	White-4	
A20	IN15	Black-2		B20	0V	Black-4	