

RoboCylinder Short Length Type **RCP2/RCA-SRA4R**

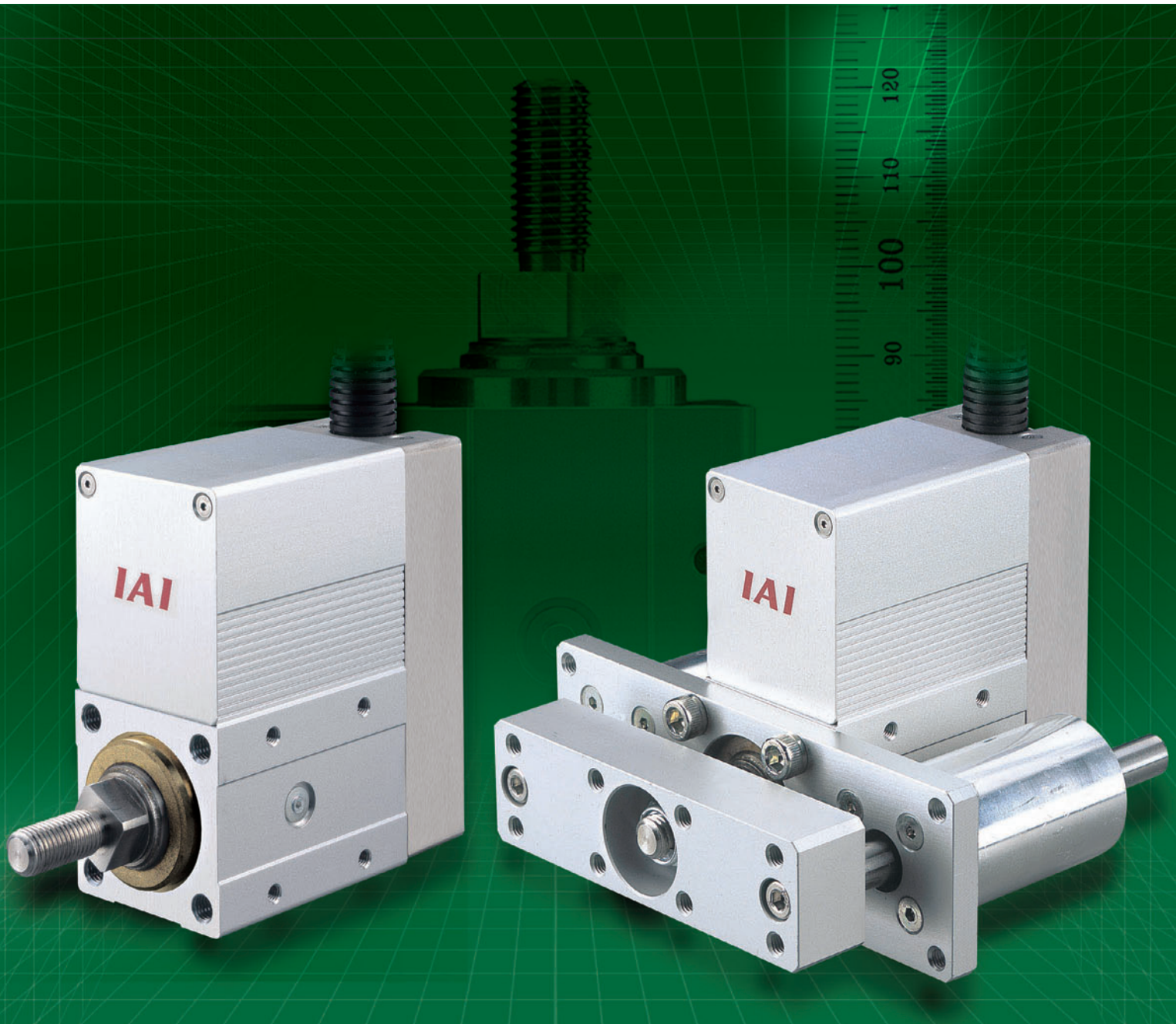

# *We have reduced the length by a maximum of 45% compared to the existing model*

## **1** Significantly shortened length

We have shortened the length of the actuator by up to 129mm compared to the current equivalent model. (\*1)  
Customers can now use the actuator in narrow locations where there is very little space.

(\*1) Compared to RCA-RA3C

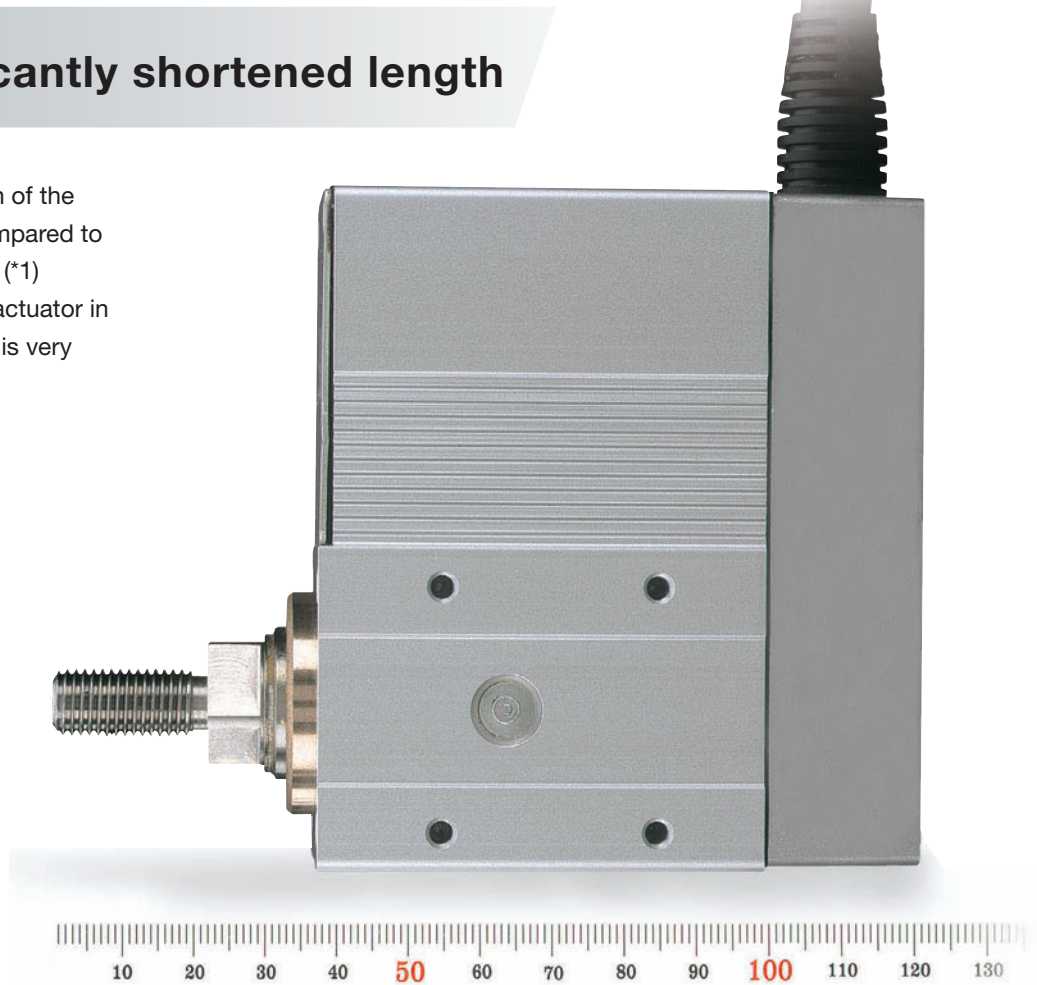

■ Length Comparison with Existing Model

**Compared to RCA-RA3C**

(RCA-RA3C)  
50 stroke

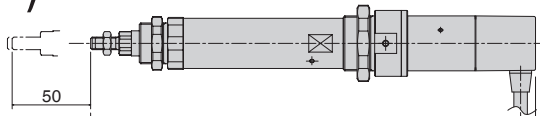

(RCA-SRA4R)  
50 stroke

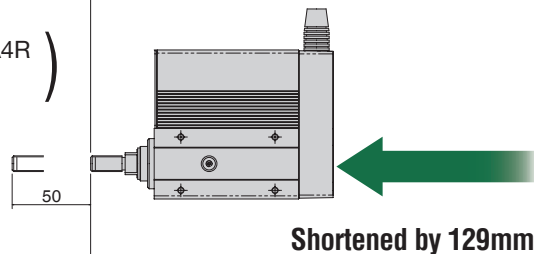

**Compared to RCA-RA3R**

(RCA-RA3R)  
50 stroke

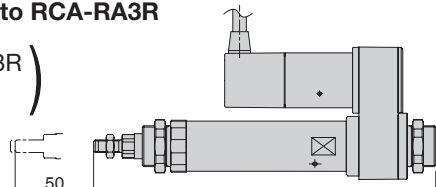

(RCA-SRA4R)  
50 stroke

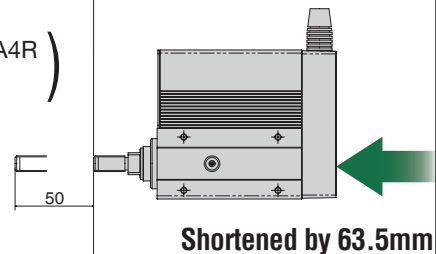

# 2

## Choose between a pulse motor or servo motor

Select between 2 types of motors: a pulse motor type suitable for push force and low-speed raising and lowering operations, or a servo motor type effective for stable transportation during high-speed operations

Pulse motor: RCP2 Series	
Usage	Low-speed raising and lowering operations, such as clamping and press fitting

Servo Motor: RCA Series	
Usage	Positioning during high-speed transfer

# 3

## A guide type can be selected

A guide type can be selected if a load is applied to the end of a rod, or if a straight motion is required. A single guide or a double guide can be selected, and for the single guide, there are 3 directions that it can be installed.

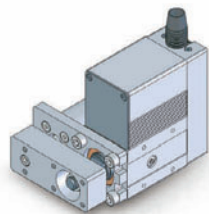

Single guide  
Installed on left

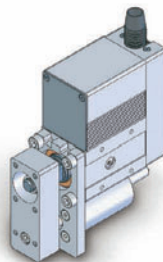

Single guide  
Installed on bottom

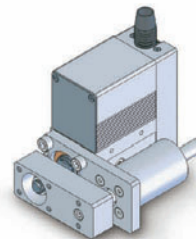

Single guide  
Installed on right

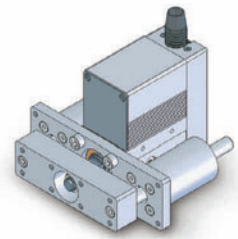

Double guide

# 4

## Flexible Installation method

There are 5 installation surfaces on the actuator. We have also prepared optional front and rear flanges and foot brackets (bottom, side).

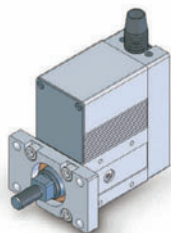

Flange  
(Installed on front)

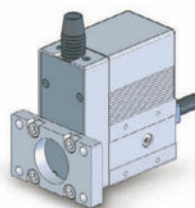

Flange  
(Installed on rear)

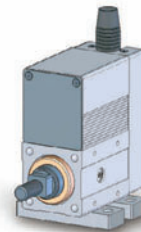

Foot bracket  
(Installed on bottom)

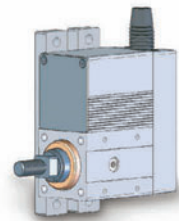

Foot bracket  
(Installed on side)

### Example of use

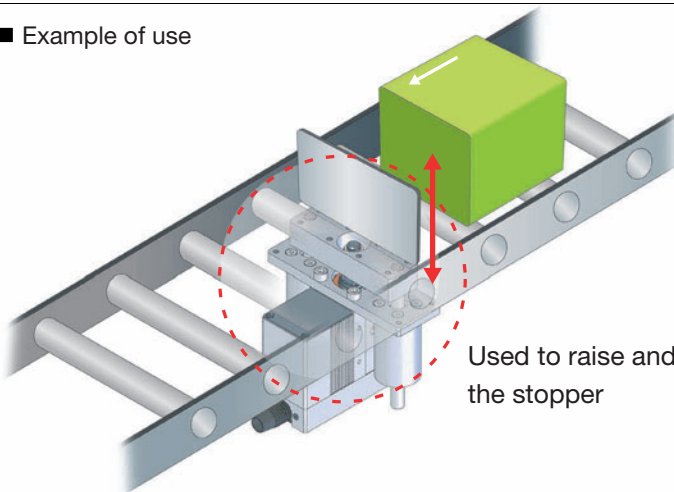

Used to raise and lower the stopper

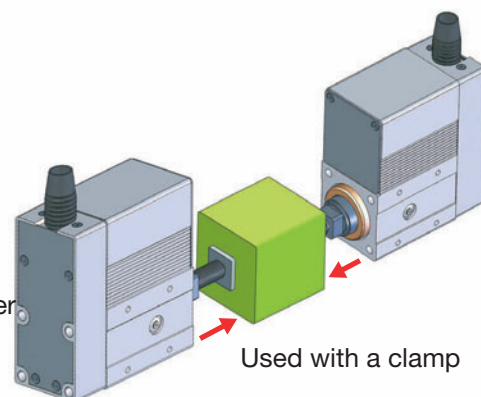

Used with a clamp

■ Product & Specification List

Series Name	Motor type	Type	Stroke	Ball screw lead	Maximum speed	Rated thrust	Maximum load capacity		Maximum pushing force
							Horizontal	Vertical	
RCP2	Pulse motor 35□	Standard (no guide)	20 to 200mm 20 to 100 are set every 10mm. 100 to 200 are set every 50mm.	5	250	—	10 to 25	2 to 9	90
		With single guide		2.5	125	—	30 to 35	3 to 15	170
		With double guide		5	250	—	9 to 24	1 to 8	90
				2.5	125	—	30 to 35	3 to 15	170
				5	250	—	9 to 24	1 to 8	90
				2.5	125	—	30 to 35	3 to 15	170
RCA	Servo Motor 20W	Standard (no guide)	20 to 200mm 20 to 100 are set every 10mm. 100 to 200 are set every 50mm.	5	250	41	9	3	—
		With single guide		2.5	125	81	18	6.5	—
		With double guide		5	250	41	9	2	—
				2.5	125	81	18	5.5	—
				5	250	41	9	2	—
				2.5	125	81	18	5.5	—

■ Model description

Pulse motor type

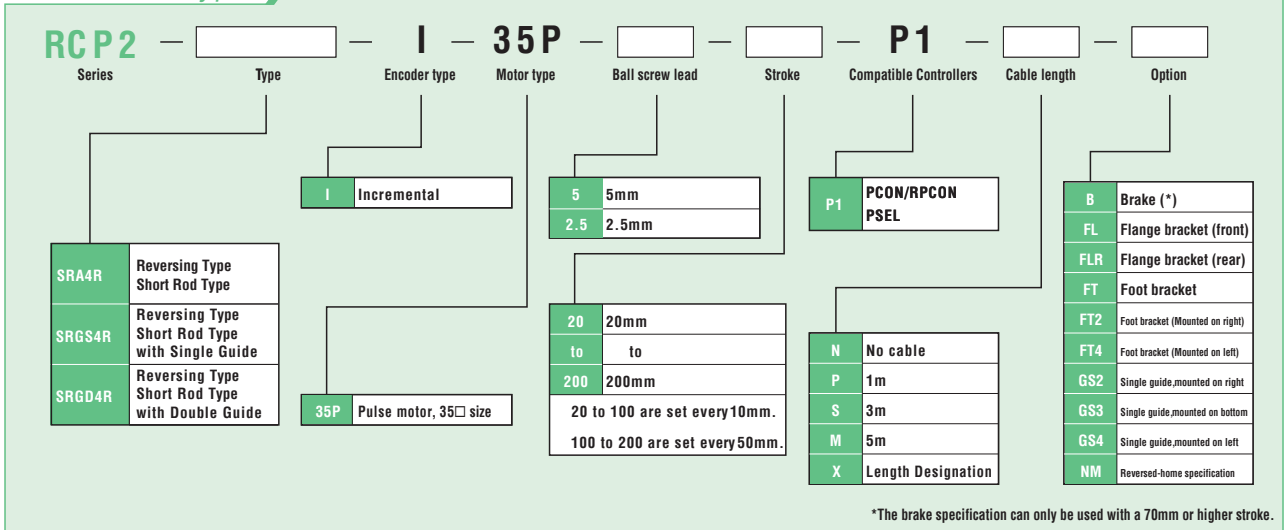

Servo Motor Type

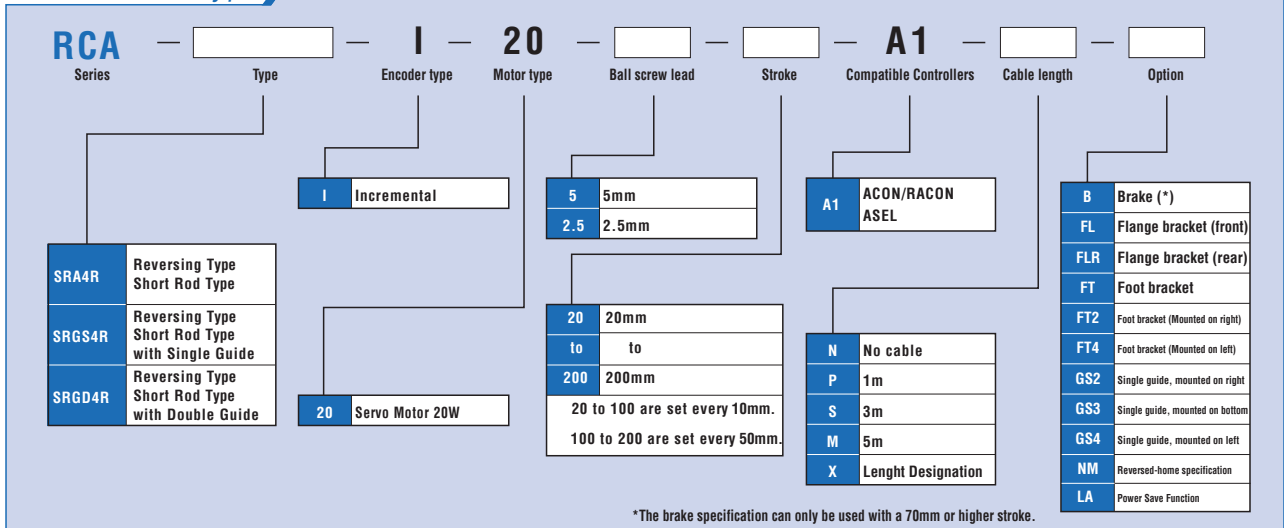

## System Configuration

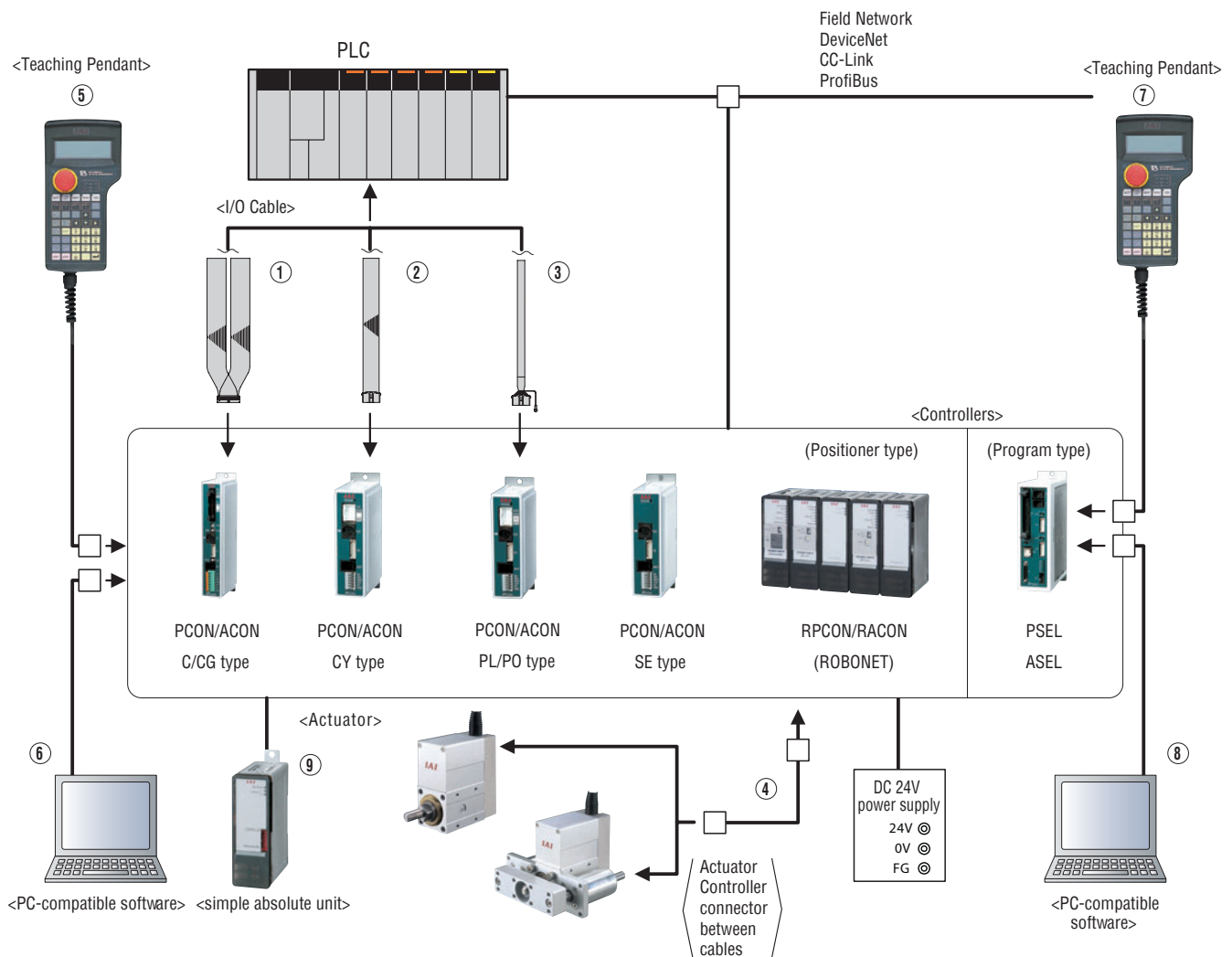

No.	Title	Type	Model	Remarks	See page
①	I/O Cable	for use with C/CGType	CB-PAC-PI0020	Cable length 2m (fitting for controller) for both PCON/ACON	(*)
		for use with CYType	CB-PACY-PI0020		(*)
		for use with PL/PO type (pulse train)	CB-PACPU-PI0020		(*)
④	Actuator Controller connector between cables	A motor/encoder integrated cable for use with RCP2 (PCON/RPCON/PSEL)	CB-PCS-MPA	Cable lengths 1m/3m/5m (required option for actuator)	P19
		A motor/encoder integrated cable for use with RCA (ACON/RACON/ASEL)	CB-ACS-MPA		P19
⑤	PositionerType Teaching Pendant	Standard Teaching Pendant	CON-T-ENG	Cable length 5m for both PCON/ACON/ROBONET	P22
		Simple Teaching Pendant	RCM-E		P22
		Data Setting Unit	RCM-P		P22
⑥	PositionerType PC software	RS232 ConnectionType	RCM-101-MW-EU	Auxillary cable for PC connection (5m) for PCON/ACON/ROBONET	P22
		USB ConnectionType	RCM-101-USB-EU		P22
⑦	ProgramType Teaching Pendant	Standard specification	SEL-T-J	Cable length 5m for both PSEL/ASEL	P22
		ANSI compatible specification	SEL-TD-J	3 position enable switch for both PSEL/ASEL	P22
⑧	ProgramType PC Software	RS232 ConnectionType	IA-101-X-MW-J	Auxillary cable for PC connection (5m) for both PSEL/ASEL	P22
		USB ConnectionType	IA-101-X-USB		P22
⑨	simple absolute unit	for PCON	PCON-ABU		(*)
		for ACON	ACON-ABU		(*)

(\*) Refer to RoboCylinder General Catalog.

# RCP2-SRA4R

ROBO Cylinder, Short Rod Type, Actuator Width 45mm, Pulse Motor, Motor Reversing Specification

Model Description	<b>RCP2</b>	—	<b>SRA4R</b>	—	<b>I</b>	—	<b>35P</b>	—		—		—	<b>P1</b>	—		—	
	Series		Type		Encoder type		Motor type		Lead		Stroke		Compatible Controllers		Cable length		Options
					I: Incremental specification		35P: Pulse motor 35□Size		5: 5mm 2.5: 2.5mm		20:20mm to 200:200mm (10mm pitch setting)		P1: PCON RPCON PSEL		N: None P: 1m S: 3m M: 5m X□□: Length designation		Options below See Options Table

\* See P3 for model descriptions. \*Every 50mm for strokes over 100mm.



- The RCP2 series uses a pulse motor so the load capacity decreases at high speeds. Confirm the payload at the desired speed in the Speed vs. Payload graph at right.
- The payload is the value when operated at 0.3G acceleration (0.2G acceleration in vertical operation with lead 2.5). The above values are maximum acceleration.
- The horizontal load capacity assumes use of an external guide. Take note that the interlock may get damaged if external force is applied from any direction other than the moving direction of the rod.

### Speed vs. Payload Graph

Since the RCP2 Series uses a pulse motor, the payload decreases as speed increases. Use the table below to confirm that there is sufficient payload at the desired speed.

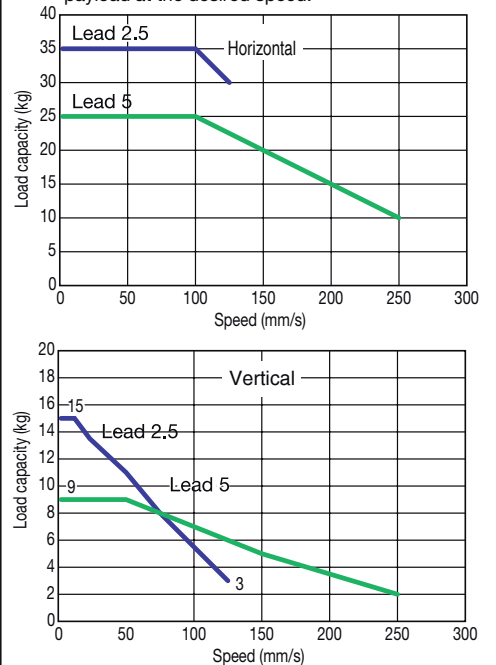

### Actuator Specifications

#### Leads and Payloads

(Note 1) Note that the maximum load capacity decreases as the speed increases.

Model	Lead (mm)	Maximum payload (Note 1)		Maximum pushing force (N) (Note 2)	Stroke (mm)
		Horizontal (kg)	Vertical (kg)		
RCP2-SRA4R-I-35P-5--P1-- ③②①	5	25	9	90	20 to 200 (every 10mm)
RCP2-SRA4R-I-35P-2.5--P1-- ③②①	2.5	35	15	170	(Note 3)

Legend Stroke Cable Length Option ③ ② ①

(Note 2) Refer to the push force graph on P17.  
(Note 3) Every 50mm stroke at over 100mm.

(Unit = mm/s)

#### Stroke and Maximum Speed

Lead	Stroke	
	Stroke (mm)	20 to 200 (every 10mm)
5	250	
2.5		125

### Cable Length

Type	Cable symbol
Standard type	P (1m)
	S (3m)
	M (5m)
Special length	X06 (6m) - X10 (10m)
	X11 (11m) - X15 (15m)
	X16 (16m) - X20 (20m)

\*A built-in motor-encoder cable is standard, and meets the robot cable specification.

\*See P19 for maintenance cables.

### Actuator Specifications

Item	Description
Drive System	Ball screw φ8mm rolled C10
Positioning Repeatability	±0.05mm
Backlash	0.1mm or less
Rod diameter	φ22mm
Non-rotary Rod Precision	-
Ambient operating temperature, humidity	0 to 40°C, 85% RH or less (without condensation)
Operating life	5000km

### Options

Title	Option code	See page
Brake	B	-
Flange bracket (front)	FL	P19
Flange bracket (rear)	FLR	P19
Foot bracket 1 (mounted on bottom)	FT	P19
Foot brackets 2 (Mounted on right or left side)	FT2/FT4	P19

\*The brake can be used at 70 stroke or above.

Dimensions Drawing

CAD drawings can be downloaded from the website. [www.robocylinder.de](http://www.robocylinder.de)

(\*1) Connect the motor and encoder cable. See P19 for cable details.  
 (\*2) During home return, the slider moves to the mechanical end and then reverses. Pay attention to prevent contact between the slider and surrounding parts.

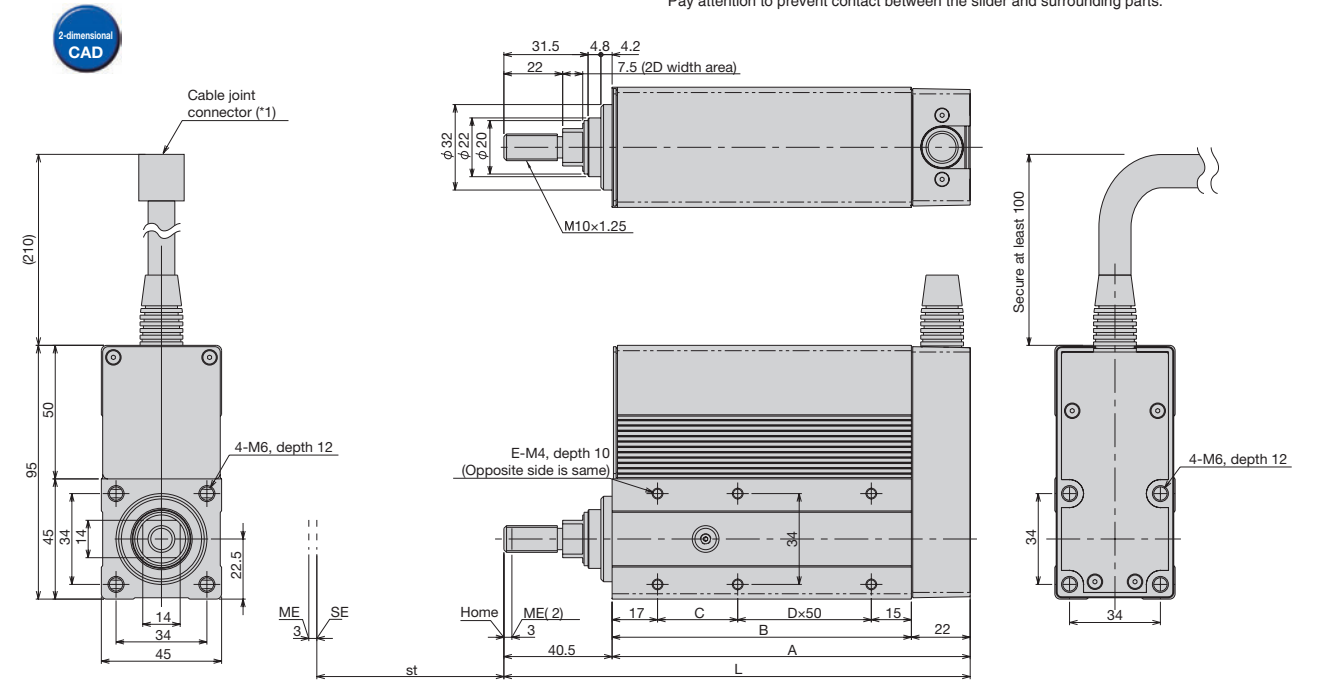

\* The brake specification does not effect the external dimensions. However, 70 is the minimum stroke for the brake specification. (The brake is not compatible at 60 strokes and under.)

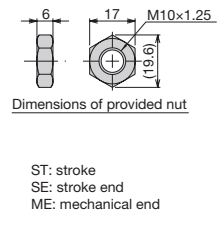

**Dimensions and Weight by Stroke** (If the unit has a brake, add 0.2kg)

Stroke	20	30	40	50	60	70	80	90	100	150	200
L	124.5	134.5	144.5	154.5	164.5	174.5	184.5	194.5	204.5	254.5	304.5
A	84	94	104	114	124	134	144	154	164	214	264
B	62	72	82	92	102	112	122	132	142	192	242
C	30	40	50	60	70	80	90	100	110	160	210
D	0	0	0	0	0	1	1	1	1	2	3
E	4	4	4	4	4	6	6	6	6	8	10
Weight (kg)	0.83	0.89	0.96	1.02	1.08	1.14	1.21	1.27	1.33	1.64	1.95

Compatible Controllers

The RCP2 Series actuators can be operated with the following controllers. Select the type that is compatible with your application.

Title	External View	Model	Features	Maximum number of positioning points	Input power	Power-supply capacity	See page
Positioner Type		PCON-C-35PI-NP-2-0	Up to 512-point positioning possible	512 points	DC24V	Maximum 2A	P20
Safety category compatible Positioner type		PCON-CG-35PI-NP-2-0					
Solenoid valve type		PCON-CY-35PI-NP-2-0	Same as solenoid valve Controlled operation enabled	3 points			
Pulse series input type (Differential line driver specification)		PCON-PL-35PI-NP-2-0	Differential line driver compatible Pulse series input type	(-)			
Pulse series input type (Open collector specification)		PCON-PO-35PI-NP-2-0	Open collector compatible Pulse series input type				
Serial communication type		PCON-SE-35PI-N-0-0	Serial communications Special Type	64 points			
Field network type(*1)		RPCON-35P	Field Network Dedicated type	768 points			
Program control type		PSEL-C-1-35PI-NP-2-0	Programmed operation enabled Maximum biaxial operation enabled	1500 points			

(\*1) In addition to the controller, the field network type also requires a Gateway unit (sold separately).

# RCP2-SRGS4R

ROBO Cylinder, Short Rod Type with Single Guide, Actuator Width 45mm, Pulse Motor, Motor Reversing Specification

Model Description	<b>RCP2</b>	<b>SRGS4R</b>	<b>I</b>	<b>35P</b>			<b>P1</b>		
	Series	Type	Encoder type	Motor type	Lead	Stroke	Compatible Controllers	Cable length	Options
			I: Incremental specification	35P: Pulse motor 35□Size	5: 5mm 2.5: 2.5mm	20:20mm to 200:200mm (10mm pitch setting)	P1: PCON RPCON PSEL	N: None P: 1m S: 3m M: 5m X□□: Length designation	Options below See Options Table

\* See P3 for model descriptions. \*Every 50mm for strokes over 100mm.

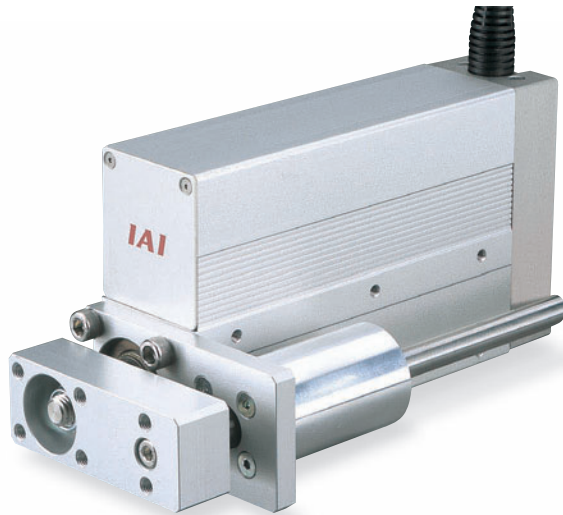

### Speed vs. Payload Graph

Since the RCP2 Series uses a pulse motor, the payload decreases as speed increases. Use the table below to confirm that there is sufficient payload at the desired speed.

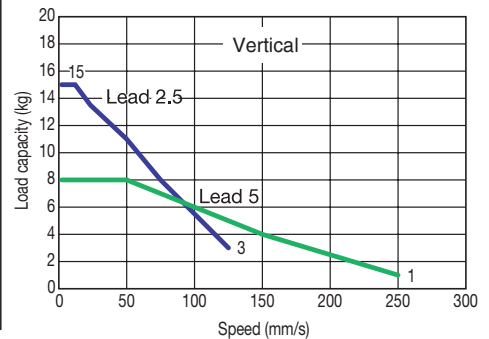
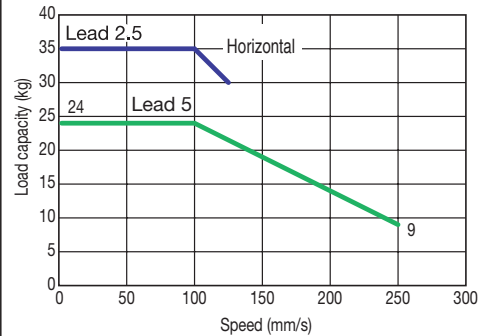

- The RCP2 series uses a pulse motor so the load capacity decreases at high speeds. Confirm the payload at the desired speed in the Speed vs. Payload graph at right.
- The payload is the value when operated at 0.3G acceleration (0.2G acceleration in vertical operation with lead 2.5). The above values are maximum acceleration.
- The horizontal load capacity assumes use of an external guide. See P.18 of the Technical Reference for the load capacities that can be used with the single guide that is provided.

### Actuator Specifications

#### Leads and Payloads

(Note 1) Note that the maximum load capacity decreases as the speed increases.

Model	Lead (mm)	Maximum payload (Note 1)		Maximum pushing force (N) (Note 2)	Stroke (mm)
		Horizontal (kg)	Vertical (kg)		
RCP2-SRGS4R-I-35P-5--P1-- ③②①	5	24	8	90	20 to 200 (every 10mm)
RCP2-SRGS4R-I-35P-2.5--P1-- ③②①	2.5	35	15	170	(Note 3)

Legend Stroke Cable Length Option ③ ② ①

(Note 2) Refer to the push force graph on P17.  
(Note 3) Every 50mm stroke at over 100mm.

(Unit = mm/s)

#### Stroke and Maximum Speed

Lead	Stroke	
	Stroke (mm)	20 to 200 (every 10mm)
5	250	
2.5		125

### Cable Length

Type	Cable symbol
Standard type	P (1m)
	S (3m)
	M (5m)
Special length	X06 (6m) - X10 (10m)
	X11 (11m) - X15 (15m)
	X16 (16m) - X20 (20m)

\*A built-in motor-encoder cable is standard, and meets the robot cable specification.

\*See P19 for maintenance cables.

### Actuator Specifications

Item	Description
Drive System	Ball screw $\phi$ 8mm rolled C10
Positioning Repeatability	$\pm$ 0.05mm
Backlash	0.1mm or less
Rod diameter	$\phi$ 22mm
Non-rotary Rod Precision	$\pm$ 0.05 degrees
Ambient operating temperature, humidity	0 to 40°C, 85% RH or less (without condensation)
Operating life	5000km

### Options

Title	Option code	See page
Brake	B	-
Flange bracket (rear)	FLR	P19
Foot bracket 1(mounted on bottom)	FT	P19
Foot brackets 2 (Mounted on right and left sides)	FT2/FT4	P19
Guide installation direction change	GS2 to GS4	P8

\*The brake can be used at 70 stroke or above.

\*Always input the direction the guide should be mounted on the model.

\*The guide and foot bracket cannot be used in the same direction.

Dimensions Drawing

CAD drawings can be downloaded from the website. [www.robocylinder.de](http://www.robocylinder.de)

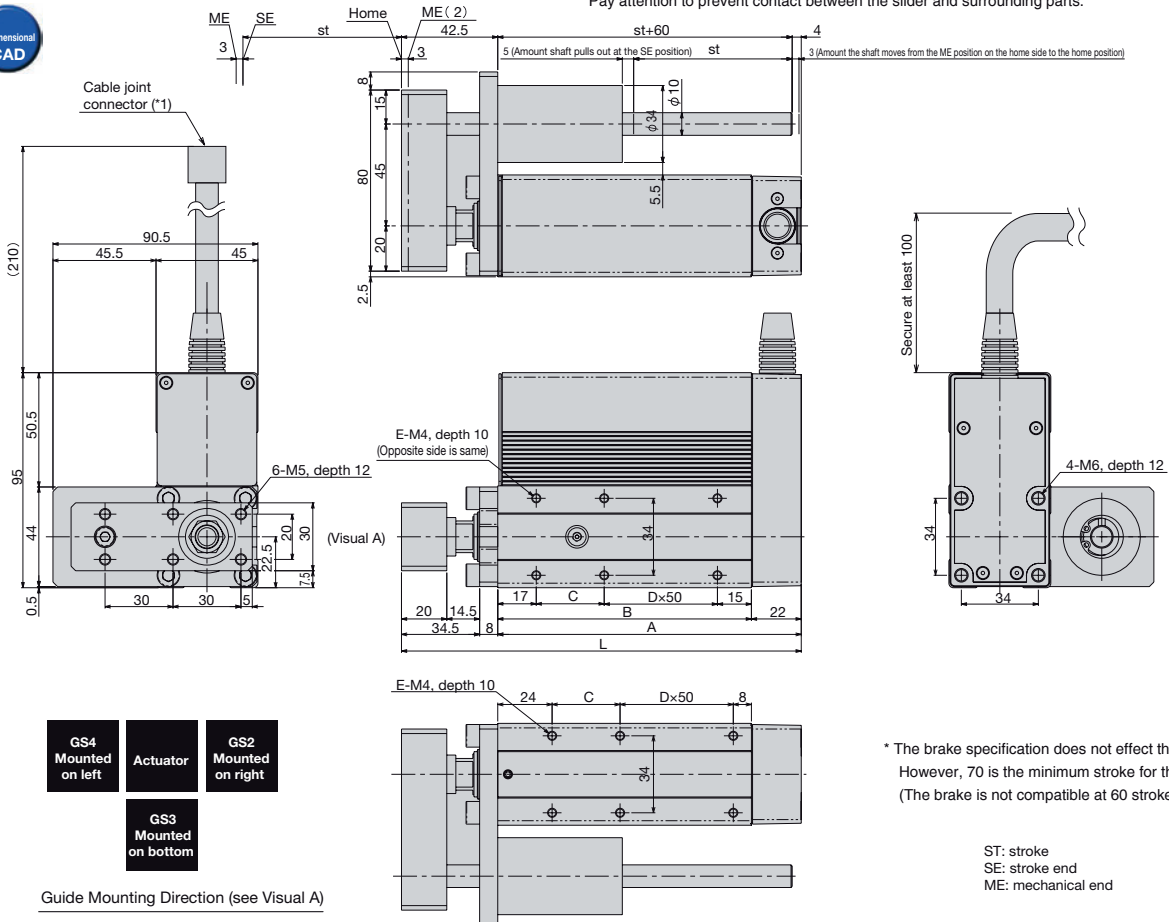

■ Dimensions and Weight by Stroke (If the unit has a brake, add 0.2kg)

Stroke	20	30	40	50	60	70	80	90	100	150	200
L	126.5	136.5	146.5	156.5	166.5	176.5	186.5	196.5	206.5	256.5	306.5
A	84	94	104	114	124	134	144	154	164	214	264
B	62	72	82	92	102	112	122	132	142	192	242
C	30	40	50	60	70	80	90	100	110	160	210
D	0	0	0	0	0	1	1	1	1	2	3
E	4	4	4	4	4	6	6	6	6	8	10
Weight (kg)	1.2	1.27	1.34	1.41	1.48	1.54	1.61	1.68	1.75	2.09	2.43

Compatible Controllers

The RCP2 Series actuators can be operated with the following controllers. Select the type that is compatible with your application.

Title	External View	Model	Features	Maximum number of positioning points	Input power	Power-supply capacity	See page
Positioner Type		PCON-C-35PI-NP-2-0	Up to 512-point positioning possible	512 points	DC24V	Maximum 2A	P20
Safety category compatible Positioner type		PCON-CG-35PI-NP-2-0					
Solenoid valve type		PCON-CY-35PI-NP-2-0	Same as solenoid valve Controlled operation enabled	3 points			
Pulse series input type (Differential line driver specification)		PCON-PL-35PI-NP-2-0	Differential line driver compatible Pulse series input type	(-)			
Pulse series input type (Open collector specification)		PCON-PO-35PI-NP-2-0	Open collector compatible Pulse series input type				
Serial communication type		PCON-SE-35PI-N-0-0	Serial communications Special Type	64 points			
Field network type(*1)		RPCON-35P	Field Network Dedicated type	768 points			
Program control type		PSEL-C-1-35PI-NP-2-0	Programmed operation enabled Maximum biaxial operation enabled	1500 points			

(\*1) In addition to the controller, the field network type also requires a Gateway unit (sold separately).





# RCA-SRA4R

ROBO Cylinder, Short Rod Type, Actuator Width 45mm, Servo Motor, Motor Reversing Specification

Model Description	RCA	SRA4R	I	20			A1		
	Series	Type	Encoder type	Motor type	Lead	Stroke	Compatible Controllers	Cable length	Options
			I: Incremental specification	20: Servo motor 20W	5: 5mm 2.5: 2.5mm	20:20mm to 200:200mm (10mm pitch setting)	A1: ACON RACON ASEL	N: None P: 1m S: 3m M: 5m X□□: Length designation	Options below See Options Table

\* See P3 for model descriptions. \*Every 50mm for strokes over 100mm.

For low-power applications



**POINT**  
Notes for selection

- (1) The payload capacity acceleration is 0.3G acceleration (0.2G acceleration in vertical operation with lead 2.5). The above value is the maximum acceleration.
- (2) There is horizontal load capacity when external guides are used. Take note that if external force is applied in any direction other than moving direction the rod, the interlock may get damaged.

Actuator Specifications						Stroke and Maximum Speed	
Leads and Payloads						Stroke (mm)	20 to 200 (every 10mm)
Model	Lead (mm)	Maximum payload (Note 1)		Rated thrust (N)	Stroke / Lead		
RCA-SRA4R-I-20-5--A1-- ③②①	5	Horizontal (kg)	Vertical (kg)	41	5	250	
RCA-SRA4R-I-20-2.5--A1-- ③②①	2.5	18	6.5	81	2.5	125	

Legend Stroke Cable Length Option ③②① (Unit = mm/s)

(Note 1) Every 50mm for strokes over 100mm.

Type	Cable symbol
Standard type	P (1m)
	S (3m)
	M (5m)
Special length	X06 (6m) – X10 (10m)
	X11 (11m) – X15 (15m)
	X16 (16m) – X20 (20m)

\*A built-in motor-encoder cable is standard, and meets the robot cable specification.  
\*See P19 for maintenance cables.

Item	Description
Drive System	Ball screw φ8mm rolled C10
Positioning Repeatability	±0.05mm
Backlash	0.1mm or less
Rod diameter	φ22mm
Non-rotary Rod Precision	–
Ambient operating temperature, humidity	0 to 40°C, 85% RH or less (without condensation)
Operating life	5000km

Title	Option code	See page
Brake	B	–
Flange bracket (front)	FL	P19
Flange bracket (rear)	FLR	P19
Foot bracket 1 (mounted on bottom)	FT	P19
Foot brackets 2 (Mounted on right or left sides)	FT2/FT4	P19
Power save function	LA	–

\*The brake can be used at 70 stroke or above.

Dimensions Drawing

CAD drawings can be downloaded from the website.

www.robocylinder.de

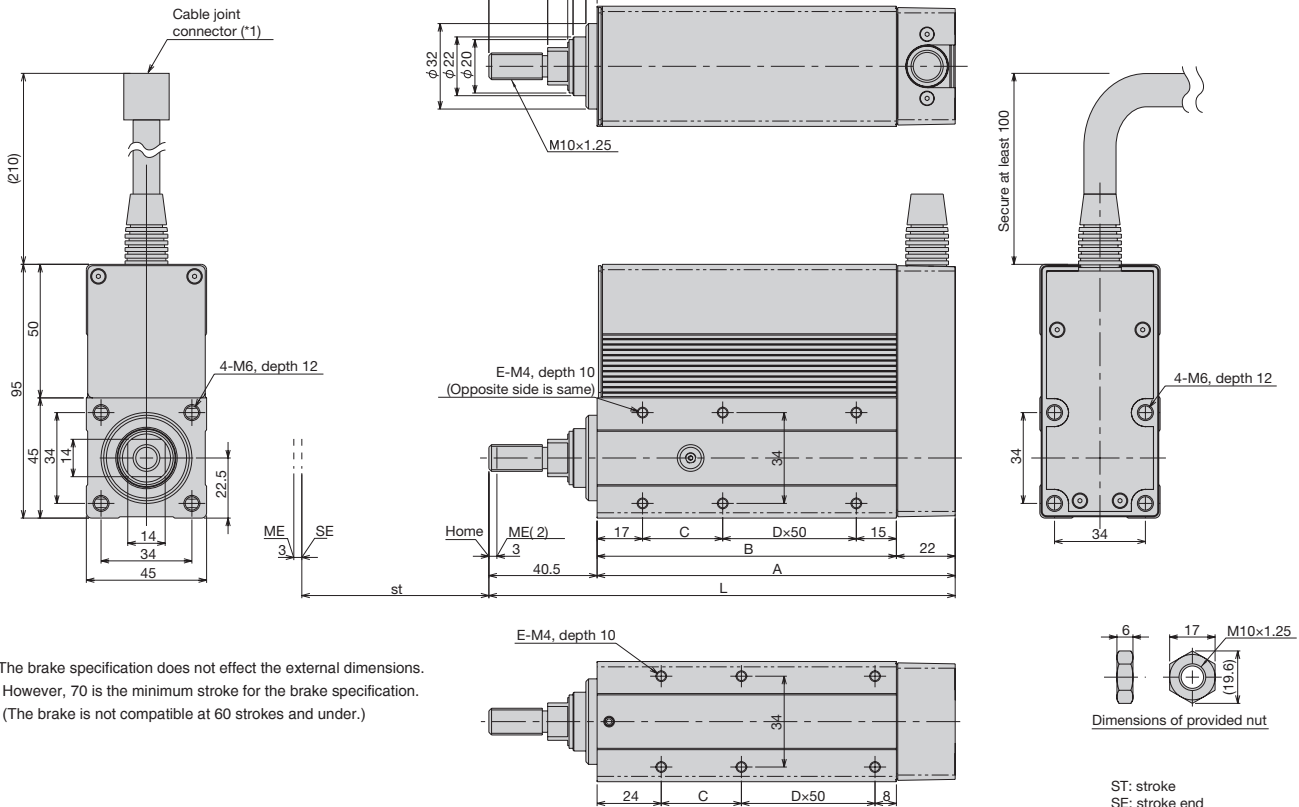

\* The brake specification does not effect the external dimensions. However, 70 is the minimum stroke for the brake specification. (The brake is not compatible at 60 strokes and under.)

■ Dimensions and Weight by Stroke (If the unit has a brake, add 0.2kg)

Stroke	20	30	40	50	60	70	80	90	100	150	200
L	124.5	134.5	144.5	154.5	164.5	174.5	184.5	194.5	204.5	254.5	304.5
A	84	94	104	114	124	134	144	154	164	214	264
B	62	72	82	92	102	112	122	132	142	192	242
C	30	40	50	60	70	30	40	50	60	60	60
D	0	0	0	0	0	1	1	1	1	2	3
E	4	4	4	4	4	6	6	6	6	8	10
Weight (kg)	0.78	0.84	0.9	0.96	1.03	1.09	1.15	1.21	1.27	1.59	1.9

Compatible Controllers

RCA Series actuators can be operated with the following controllers. Select the type that is compatible with your application.

Title	External View	Model (*2)	Features	Maximum number of positioning points	Input power	Power-supply capacity	See page
Positioner Type		ACON-C-20I①-NP-2-0	Up to 512-point positioning possible	512 points	DC24V	(Standard) Rated 1.3A Peak 4.4A	P20
Safety category compatible Positioner type		ACON-CG-20I①-NP-2-0					
Solenoid valve type		ACON-CY-20I①-NP-2-0	Same as solenoid valve Controlled operation enabled	3 points			
Pulse series input type (Differential line driver specification)		ACON-PL-20I①-NP-2-0	Differential line driver compatible Pulse series input type	(-)			
Pulse series input type (Open collector specification)		ACON-PO-20I①-NP-2-0	Open collector compatible Pulse series input type				
Serial communication type		ACON-SE-20I①-N-0-0	Serial communications Special Type	64 points			
Field network type (*1)		RACON-20①	Field Network Dedicated type	768 points			
Program control type		ASEL-C-1-20I①-NP-2-0 (*3)	Programmed operation enabled Maximum biaxial operation enabled	1500 points			

(\*1) In addition to the controller, the field network type also requires a Gateway unit (sold separately). (\*2) ① is entered as the code (LA) when designating for low-power applications. (\*3) ASEL is for uniaxial specification.

# RCA-SRGS4R

ROBO Cylinder, Short Rod Type with Single Guide, Actuator Width 45mm, Servo Motor, Motor Reversing Specification

Model Description	<b>RCA</b>	<b>SRGS4R</b>	<b>I</b>	<b>20</b>			<b>A1</b>		
Series	Type	Encoder type	Motor type	Lead	Stroke	Compatible Controllers	Cable length	Options	
I: Incremental specification	20: Servo motor 20W	5: 5mm 2.5:2.5mm	20:20mm to 200:200mm (10mm pitch setting)	A1: ACON RACON ASEL	N: None P: 1m S: 3m M: 5m X□□: Length designation	Options below See Options Table			

\* See P3 for model descriptions. \*Every 50mm for strokes over 100mm.

For low-power applications

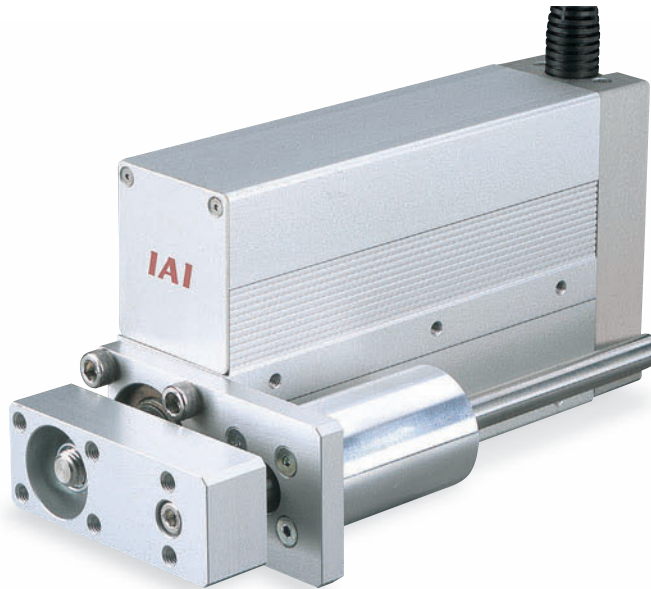

**POINT**  
Notes for selection

- (1) The payload capacity acceleration is 0.3G acceleration (0.2G acceleration in vertical operation with lead 2.5). The above value is the maximum acceleration.
- (2) There is horizontal load capacity when external guides are used. See P.18 of the Technical Reference for the load capacities that can be used with the single guide that is provided.

Actuator Specifications						Stroke and Maximum Speed	
Leads and Payloads						Stroke	20 to 200 (every 10mm)
Model	Lead (mm)	Maximum payload (Note 1) Horizontal (kg) / Vertical (kg)	Rated thrust (N)	Stroke (mm)	Lead	Stroke	20 to 200 (every 10mm)
RCA-SRGS4R-I-20-5--A1-- ③②①	5	9 / 2	41	20 to 200 (every 10mm)	5	250	
RCA-SRGS4R-I-20-2.5--A1-- ③②①	2.5	18 / 5.5	81	(Note 1)	2.5	125	

Legend Stroke Cable Length Option ③②① (Unit = mm/s)

(Note 1) Every 50mm for strokes over 100mm.

Type	Cable symbol
Standard type	P (1m)
	S (3m)
	M (5m)
Special length	X06 (6m) - X10 (10m)
	X11 (11m) - X15 (15m)
	X16 (16m) - X20 (20m)

\*A built-in motor-encoder cable is standard, and meets the robot cable specification.  
\*See P19 for maintenance cables.

Item	Description
Drive System	Ball screw φ8mm rolled C10
Positioning Repeatability	±0.05mm
Backlash	0.1mm or less
Rod diameter	φ22mm
Non-rotary Rod Precision	±0.05 degrees
Ambient operating temperature, humidity	0 to 40°C, 85% RH or less (without condensation)
Operating life	5000km

Title	Option code	See page
Brake	B	—
Flange bracket (rear)	FLR	P19
Foot bracket 1 (mounted on bottom)	FT	P19
Foot brackets 2 (Mounted on right and left sides)	FT2/FT4	P19
Guide mounting direction	GS2 to GS4	P14
Power save function	LA	—

\*The brake can be used at 70 stroke or above.  
\*Always input the direction the guide should be mounted on the model.  
\*The guide and foot bracket cannot be used in the same direction.

Dimensions Drawing

CAD drawings can be downloaded from the website. [www.robocylinder.de](http://www.robocylinder.de)

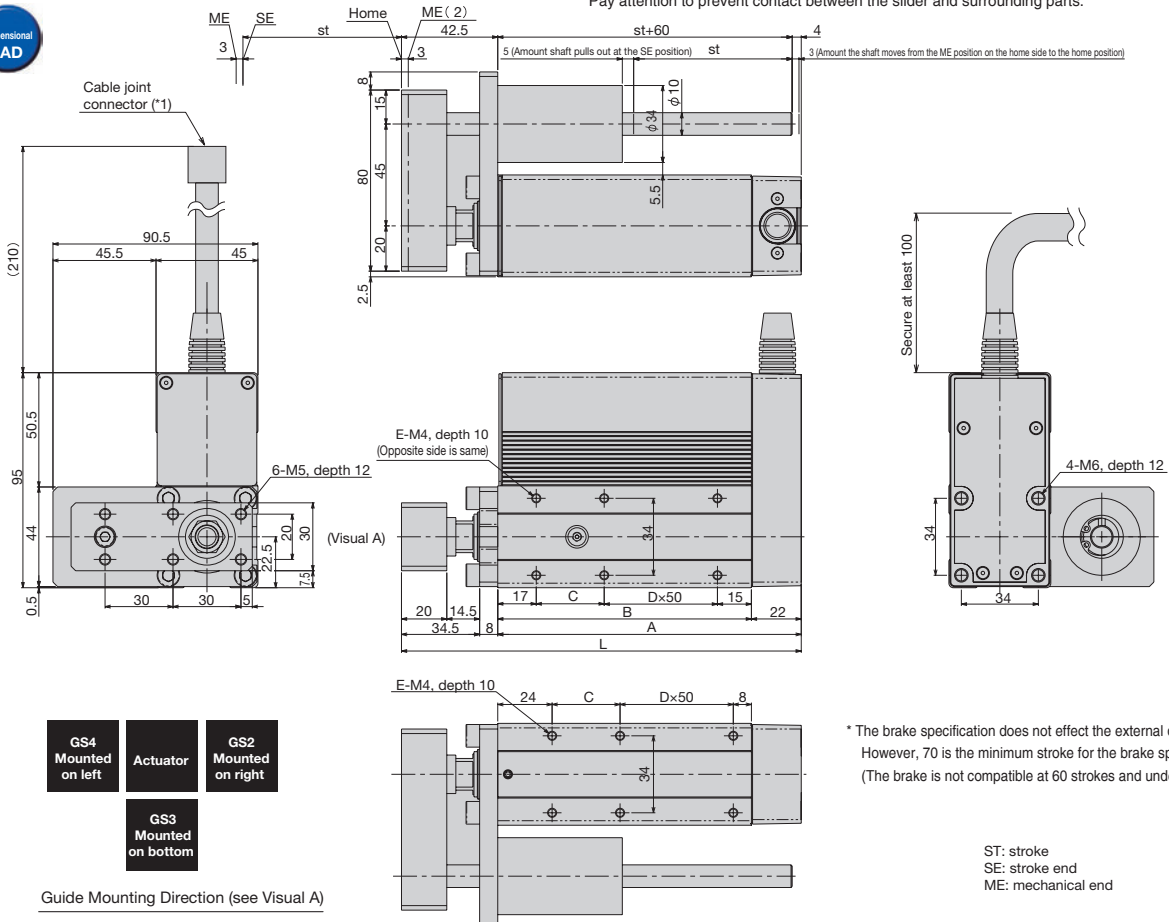

Dimensions and Weight by Stroke

(If the unit has a brake, add 0.2kg)

Stroke	20	30	40	50	60	70	80	90	100	150	200
L	126.5	136.5	146.5	156.5	166.5	176.5	186.5	196.5	206.5	256.5	306.5
A	84	94	104	114	124	134	144	154	164	214	264
B	62	72	82	92	102	112	122	132	142	192	242
C	30	40	50	60	70	80	90	100	110	160	210
D	0	0	0	0	0	1	1	1	1	2	3
E	4	4	4	4	4	6	6	6	6	8	10
Weight (kg)	1.15	1.21	1.28	1.35	1.42	1.49	1.56	1.62	1.69	2.03	2.38

Compatible Controllers

RCA Series actuators can be operated with the following controllers. Select the type that is compatible with your application.

Title	External View	Model (*2)	Features	Maximum number of positioning points	Input power	Power-supply capacity	See page
Positioner Type		ACON-C-20I①-NP-2-0	Up to 512-point positioning possible	512 points	DC24V	(Standard) Rated 1.3A Peak 4.4A	P20
Safety category compatible Positioner type		ACON-CG-20I①-NP-2-0					
Solenoid valve type		ACON-CY-20I①-NP-2-0	Same as solenoid valve Controlled operation enabled	3 points			
Pulse series input type (Differential line driver specification)		ACON-PL-20I①-NP-2-0	Differential line driver compatible Pulse series input type	(-)			
Pulse series input type (Open collector specification)		ACON-PO-20I①-NP-2-0	Open collector compatible Pulse series input type				
Serial communication type		ACON-SE-20I①-N-0-0	Serial communications Special Type	64 points			
Field network type (*1)		RACON-20I①	Field Network Dedicated type	768 points			
Program control type		ASEL-C-1-20I①-NP-2-0 (*3)	Programmed operation enabled Maximum biaxial operation enabled	1500 points			

(\*1) In addition to the controller, the field network type also requires a Gateway unit (sold separately). (\*2) ① is entered as the code (LA) when designating for low-power applications. (\*3) ASEL is for uniaxial specification.

# RCA-SRGD4R

ROBO Cylinder, Short Rod Type with Double Guide, Actuator Width 45mm, Servo Motor, Motor Reversing Specification

Model Description	<b>RCA</b>	<b>SRGD4R</b>	<b>I</b>	<b>20</b>			<b>A1</b>		
Series	Type	Encoder type	Motor type	Lead	Stroke	Compatible Controllers	Cable length	Options	
		I: Incremental specification	20: Servo motor 20W	5: 5mm 2.5:2.5mm	20:20mm to 200:200mm (10mm pitch setting)	A1: ACON RACON ASEL	N: None P: 1m S: 3m M: 5m X□□: Length designation	Options below See Options Table	

\* See P3 for model descriptions. \*Every 50mm for strokes over 100mm.

For low-power applications

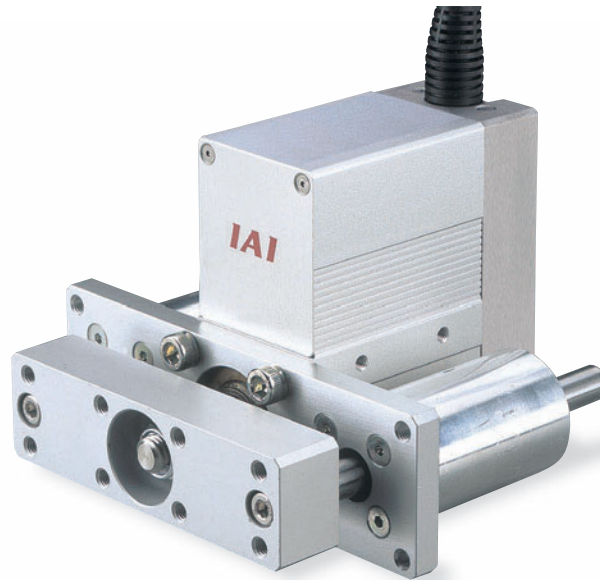

**POINT**  
Notes for selection

- (1) The payload capacity acceleration is 0.3G acceleration (0.2G acceleration in vertical operation with lead 2.5). The above value is the maximum acceleration.
- (2) There is horizontal load capacity when external guides are used. See P.18 of the Technical Reference for the load capacities that can be used with the double guide that is provided.

Actuator Specifications						Stroke and Maximum Speed	
Leads and Payloads						Stroke (mm)	20 to 200 (every 10mm)
Model	Lead (mm)	Maximum payload (Note 1)		Rated thrust (N)	Lead		
RCA-SRGD4R-I-20-5--A1-- ③ ② ①	5	9	2	41	20 to 200 (every 10mm)	5	250
RCA-SRGD4R-I-20-2.5--A1-- ③ ② ①	2.5	18	5.5	81	(Note 1)	2.5	125

Legend Stroke Cable Length Option ③ ② ① (Unit = mm/s)

(Note 1) Every 50mm for strokes over 100mm.

Cable Length	
Type	Cable symbol
Standard type	P (1m)
	S (3m)
	M (5m)
Special length	X06 (6m) – X10 (10m)
	X11 (11m) – X15 (15m)
	X16 (16m) – X20 (20m)

\*A built-in motor-encoder cable is standard, and meets the robot cable specification.  
\*See P19 for maintenance cables.

Actuator Specifications	
Item	Description
Drive System	Ball screw φ8mm rolled C10
Positioning Repeatability	±0.05mm
Backlash	0.1mm or less
Rod diameter	φ22mm
Non-rotary Rod Precision	±0.05 degrees
Ambient operating temperature, humidity	0 to 40°C, 85% RH or less (without condensation)
Operating life	5000km

Options		
Title	Option code	See page
Brake	B	—
Foot bracket1(mounted on bottom)	FT	P19
Power save function	LA	—

\*The brake can be used at 70 stroke or above.  
\*The foot bracket cannot be mounted on the side.



## Diagram Showing Relationship of Push Force & Current-Limiting Value

The push force applied in push-motion operation can be changed freely by changing the current-limiting value in the controller.

Use the graph below to check the required push force.

### Caution for Use

- The relationships of push force the and current-limiting value represent reference values and may differ slightly from actual values.
- If the current-limiting value is less than 20%, the push force may fluctuate. Keep the current-limiting value to 20% or above.
- The travel speed is fixed to 20 mm/s during push-motion operation.
- For applications requiring the use of push operation, please use the RCP2. (Pulse Motor)

**RCP2-SRA4R/SRGS4R/SRGD4R**  
**Drawing Showing Correlation Between**  
**Push Force & Current-Limiting Value**

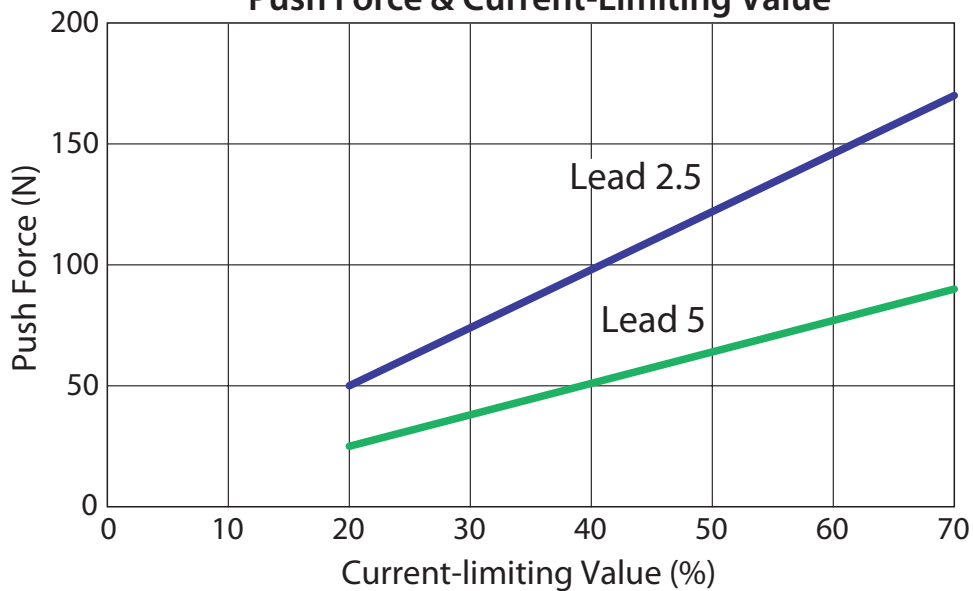

## Allowable Rotating Torque

If rotating torque is to be applied, keep the torque within the range specified below.

Take note that standard and single-guide types cannot receive rotating torque.

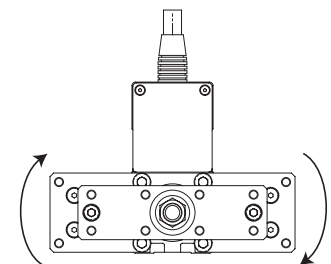
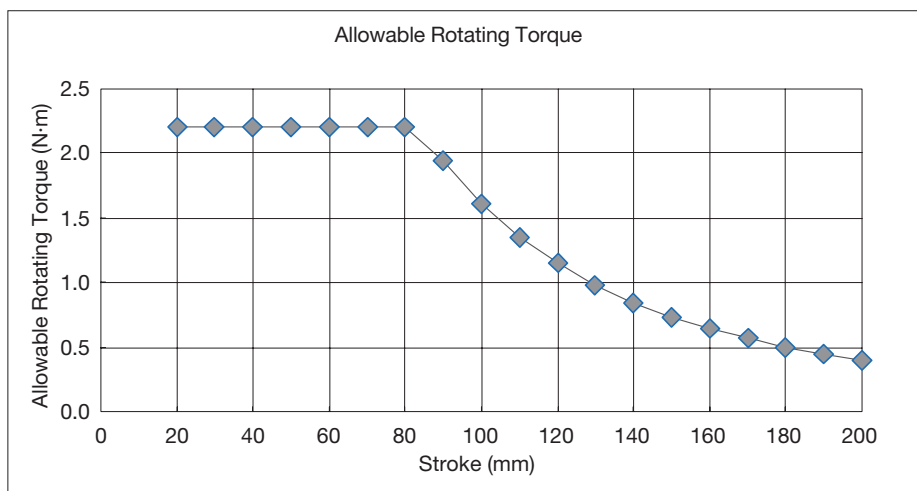

Relationship of Allowable Load at Tip & Traveling Life

The greater the load at the guide tip, the shorter the traveling life becomes.

Select an appropriate model by considering an optimal balance between load and life.

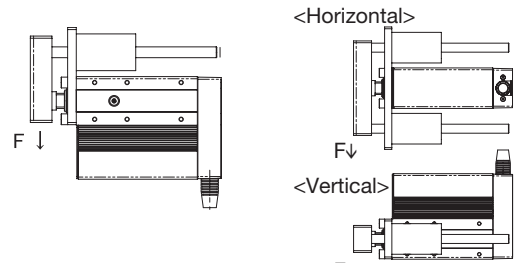

Single guide type

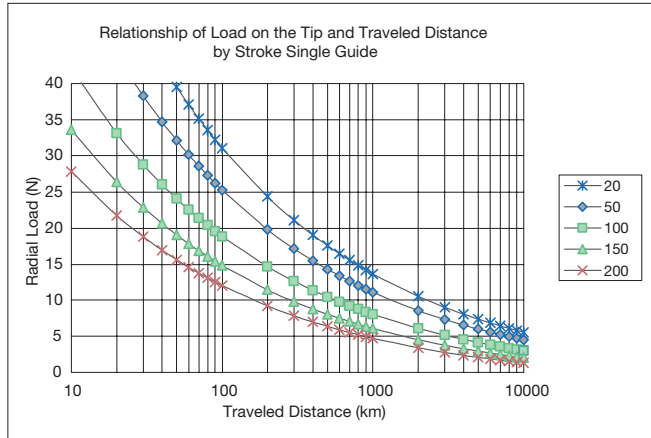

Double guide type (vertical and horizontal) F<sub>v</sub>

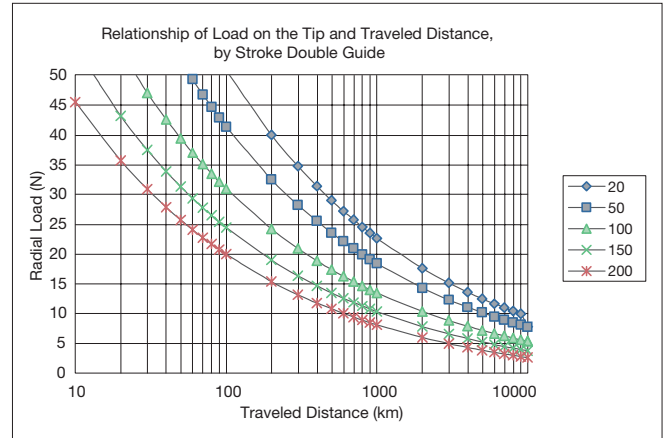

Radial Load & Deflection at Tip

The diagrams below show how the load applied at the tip of the guide correlates with the deflection that results.

Single guide type

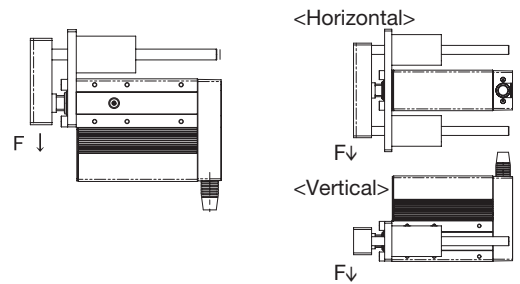
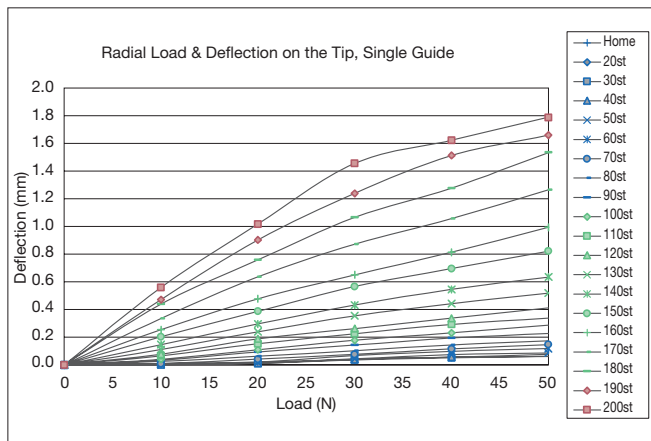

Double guide type (vertical)

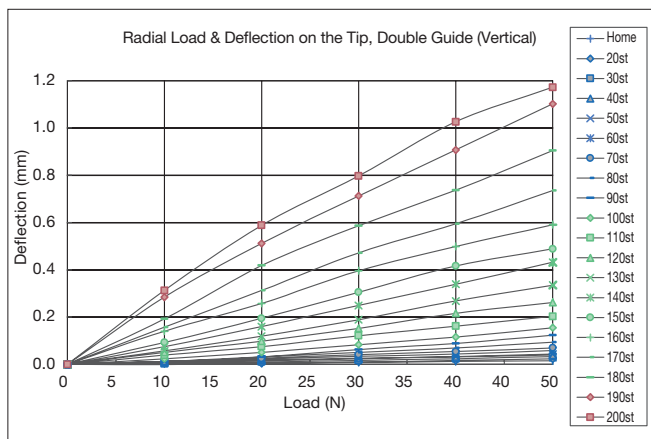

Double guide type (horizontal)

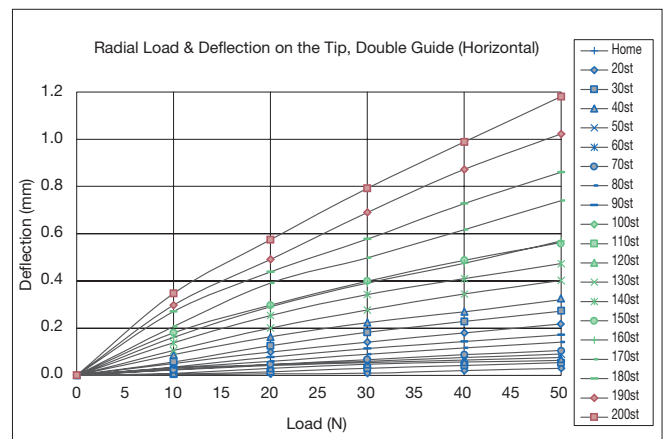

Actuator options (flange/foot brackets)

Model Options [FL]  
Single Model, RCP2-FL-SRA4

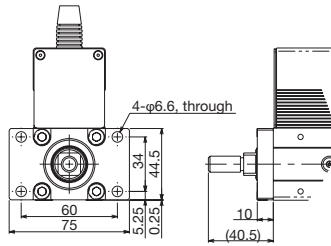

When flange bracket (front) is mounted

Model Options [FLR]  
Single Model, RCP2-FL-SRA4

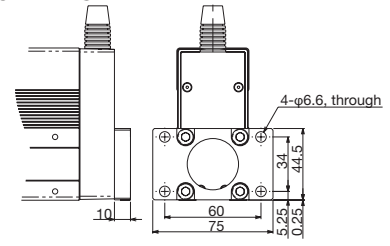

When flange bracket (rear) is mounted

Model Options [FT]  
Single Model, RCP2-FT-SRA4

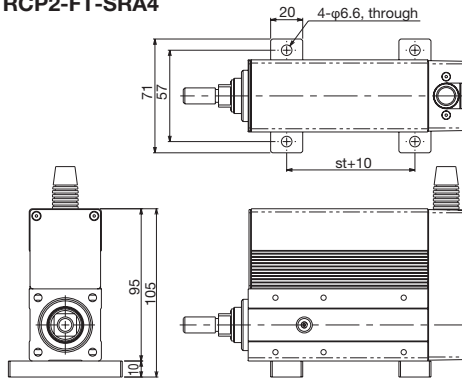

When foot bracket (bottom) is mounted

Model Options [FT2 (mounted on right side)/FT4 (mounted on left side)]  
Single Model, RCP2-FTS-SRA4

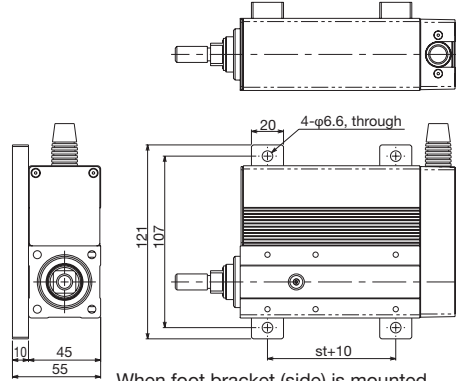

When foot bracket (side) is mounted

Maintenance parts (motor-encoder cable)

Motor-encoder cable for RCP2

Model **CB-PCS-MPA** □ □ □

\*Enter the cable length (L) for □ □ □, up to a maximum compatible length of 20m. Example: 080=8m

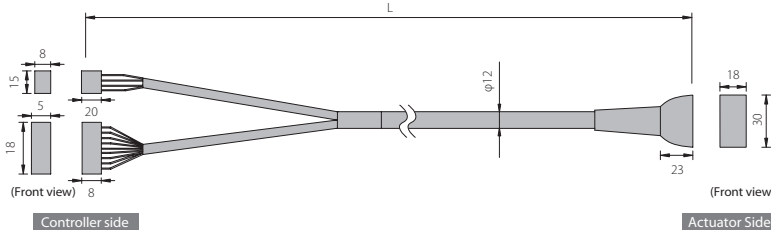

Signal	Pin No.	Wire color	Signal	Pin No.
A	B1	Black	A1	A
VMM	A2	White	B1	VMM
/A	A1	Red	A2	/A
B	B3	Green	B2	B
VMM	B2	Yellow	A3	VMM
/B	A3	Brown	B3	/B
			A4	NC
			B4	NC
BK+	14	Pink (Red-)	A5	BK+
BK-	13	Pink (Blue-)	B5	BK-
LS+	16	White (Red-)	A6	LS+
LS-	15	White (Blue-)	B6	LS-
A+	12	Orange (Red-)	A7	A+
A-	11	Orange (Blue-)	B7	A-
B+	10	Gray (Red-)	A8	B+
B-	9	Gray (Blue-)	B8	B-
NC	8		A9	NC
VPS	7	Orange (Blue-consecutive)	B9	VPS
VCC	6	Gray (Red-consecutive)	A10	VCC
GND	5	Gray (Blue-consecutive)	B10	GND
NC	4		A11	NC
FG	1	Shield	B11	FG

Motor-encoder cable for RCA

Model **CB-ACS-MPA** □ □ □

\*Enter the cable length (L) for □ □ □, up to a maximum compatible length of 20m. Example: 080=8m

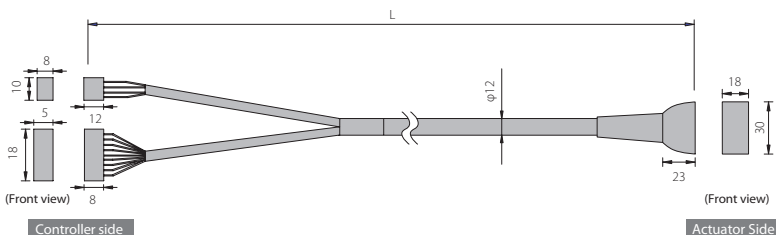

Signal	Pin No.	Wire color	Pin No.	Signal
U	1	Red	A1	U
V	2	Yellow	B1	V
W	3	Black	A2	W
			B2	NC
			A3	NC
			B3	NC
BK+	16	Yellow (Red-)	A4	BK+
BK-	15	Yellow (Blue-)	B4	BK-
LS+	18	Pink (Red-)	A5	LS+
LS-	17	Pink (Blue-)	B5	LS-
A+	14	White (Red-)	A6	A+
A-	13	White (Blue-)	B6	A-
B+	12	Orange (Red-)	A7	B+
B-	11	Orange (Blue-)	B7	B-
Z+	10	Gray (Red-)	A8	Z+
Z-	9	Gray (Blue-)	B8	Z-
-	8		A9	-
/PS	7	Orange (Red-consecutive)	B9	/PS
VCC	6	Gray (Red-consecutive)	A10	VCC
GND	5	Gray (Blue-consecutive)	B10	GND
NC			A11	NC
FG	1	Shield	B11	FG

# RCP2/RCA Controllers

## Model List

Model	PCON/ACON					RPCON RACON (ROBONET)	PSEL/ASEL
	C	CG	CY	PL/PO	SE		
Name	Positioner type	Safety category compatible type	Solenoid valve type	Pulse in-line control type	Serial Communication Type	Field Network type	Program Type
Appearance							
Features	Positioner can be positioned for up to 512 points.	Safety category compatible specification	Can be operated using the same control as an air cylinder.	An in-line pulse can be used to control as desired	Serial Communication Dedicated Controller (*1)	Can be operated through DeviceNet CC-Link ProfiBus	Programmable, Built-in Sequence Function

(\*1) A Gateway unit (sold separately) is required to use RPCON/RACON.

## Model

### [PCON/ACON Controller]

**PCON/ACON** - [ ] - [ ] - [ ] - [ ] - **0** - [ ]

Type      Motor/Encoder Type      I/O Type      I/O Cable Length      Power supply      Simple absolute unit

<b>C</b> Positioner type	<b>35PI</b> For RCP2-SRA4R/SRGS4R/SRGD4R	<b>NP</b> NPN specification	<b>0</b> No cable (*1)	<b>ABU</b> For use with simple absolute unit
<b>CG</b> Safety Category Compatible Type	<b>20I</b> For RCA-SRA4R/SRGS4R/SRGD4R	<b>PN</b> PNP specification	<b>2</b> 2m	<b>None</b> Not for use with simple absolute unit
<b>CY</b> Solenoid valve type		<b>N</b> No I/O (SE type)	<b>3</b> 3m	
<b>PL</b> Pulse-train control type (differential receiver type)		<b>DV</b> DeviceNet connection specification (*2)	<b>5</b> 5m	<b>0</b> DC24V
<b>PO</b> Pulse-train control type (open collector type)		<b>CC</b> CC-Link connection specification (*2)		
<b>SE</b> Serial Communication Type		<b>PR</b> ProfiBus connection specification (*2)		

\*For RCA models with power save function add "LA" at "ASEL Motor/Encoder Type".

(\*1) The PCON/ACON-SE and PCON/ACON-C(CG)-DV/CC/PR types have no I/O.  
 (\*2) The network specification (DV/CC/PR) is only compatible with the positioner type (C) and safety category compatible type (CG).

### [ROBONET Controller]

**RPCON/RACON** - [ ] - [ ]

Motor type      Simple absolute unit

<b>35P</b> For RCP2-SRA4R/SRGS4R/SRGD4R	<b>ABU</b> For use with simple absolute unit
<b>20</b> For RCA-SRA4R/SRGS4R/SRGD4R	<b>None</b> Not for use with simple absolute unit

\* A Gateway unit is required to connect a network when using the RPCON/RACON types. See the ROBONET catalog for details.

### [PSEL/ASEL Controller]

**PSEL/ASEL** - **C** - [ ] - [ ] - [ ] - [ ] - [ ] - **0**

Number of axes for connection      Motor/Encoder Type (1-axis) (\*2)      Motor/Encoder Type (2-axis)      I/O Type      I/O Cable Length      Power supply

<b>1</b> 1-axis specification	<b>35PI</b> For RCP2-SRA4R/SRGS4R/SRGD4R	<b>35PI</b> For RCP2-SRA4R/SRGS4R/SRGD4R	<b>NP</b> NPN specification	<b>0</b> DC24V
<b>2</b> 2-axis specification	<b>35PIB</b> Use with the brake specifications in the above model	<b>35PIB</b> Use with the brake specifications in the above model	<b>PN</b> PNP specification	<b>0</b> No cable (*1)
	<b>20I</b> For RCA-SRA4R/SRGS4R/SRGD4R	<b>20I</b> For RCA-SRA4R/SRGS4R/SRGD4R	<b>DV</b> DeviceNet connection specification	<b>2</b> 2m
	<b>20IB</b> Use with the brake specifications in the above model	<b>20IB</b> Use with the brake specifications in the above model	<b>CC</b> CC-Link connection specification	<b>3</b> 3m
			<b>PR</b> ProfiBus connection specification	<b>5</b> 5m

\*Information under "2-axis" is not required for a 1-axis specification.  
 \*\*For RCA models with power save function add "LA" at "ASEL Motor/Encoder Type".

(\*1) The network specification (DV/CC/PR) types have no I/O.

Specification Table

Item		Specification						
Controller type	PCON/ACON						RPCON/RACON (ROBONET)	PSEL/ASEL
	C	CG	CY	PL	PO	SE		
Maximum number of control axes	1-axis						Up to 16-axis can be connected and operated.	2-axes
Operation method	Positioner type		Solenoid valve type	Pulse series input type		Serial Communication Type	Field Network	Program
Number of positions	512 points		3 points	-		64 points	768 points	1500 points
I/O connector	40-pin connector		12-pin connector	14-pin connector		-	-	34-pin connector
Number of I/O	16 input, 16 output		4 input 6 output	4 input, 4 output		-	-	24 input 8 output
Serial communications	RS485							RS232
Peripheral Device Cables for communicating	CB-PAC-PIO		CB-PACY-PIO	CB-PACPU-PIO		CB-RCB-CTL002	-	CB-DS-PIO
Command pulse input method	-			Differential line driver	Open collector	-		
Maximum input pulse frequency	-			200kpps	60kpps	-		
Position detection method	Incremental encoder							
Motor/Encoder cable	CB-PCS-MPA□□□ (for PCON/PSEL) / CB-ACS-MPA□□□ (for ACON/ASEL) (Max. length 20m)							
Input power	DC24V±10%							
Power-supply capacity	<b>RCP2 (all models)</b>		Maximum 2A				Max. 2A (*1)	Max. 5.5A
	<b>RCA</b>	<b>SRA4R SRGS4R SRGD4R</b>	Rated 1.3A, max. 4.4A (standard specification) Rated 1.3A, max. 2.5A (power-saving specification)				(*2)	(*3)
Dielectric strength voltage	DC500V 1MΩ							DC500V 10MΩ
Ambient operating temperature, Ambient operating humidity	0 to 40°C, 10 to 95% (free from condensation or corrosive gases)							
Ingress Protection	IP20							
Mass	Approx.300g		Approx.130g			Approx.200g	Approx.450g	

(\*1) During use, the following amount of power is required: 2A x the number of units used, plus the power consumed by the Gateway unit (approx. 0.6A).  
 (\*2) The following power capacity is required for RACON: ACON power capacity x number of units used, plus the power consumed by the Gateway unit (approx. 0.6A).  
 (\*3) The following power capacity is required for ASEL: ACON power capacity x number of control axes, plus the power for the control unit (1.2A).

External Dimensions

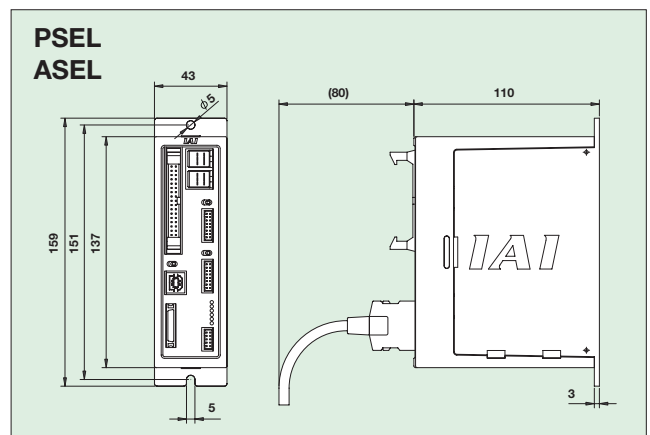
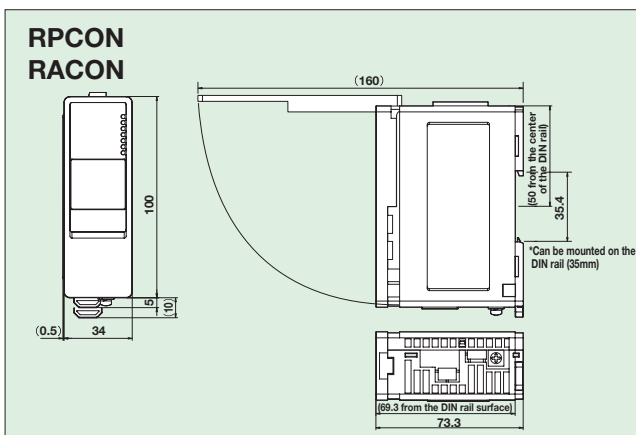
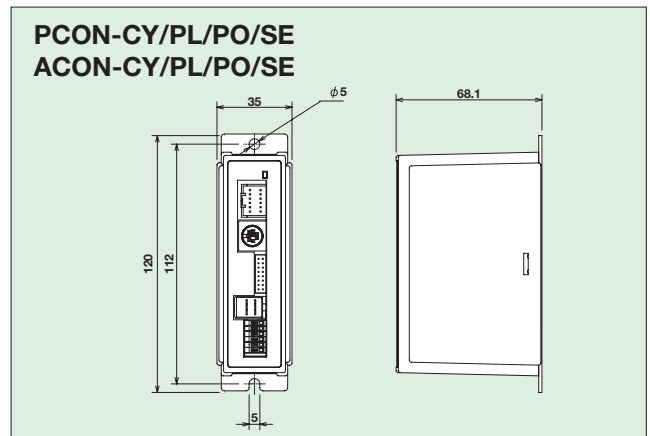
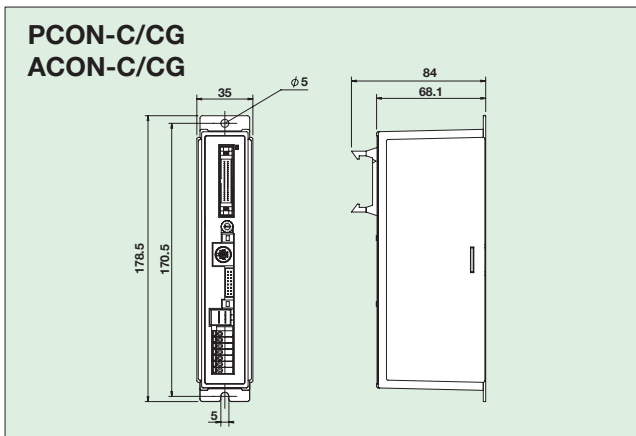

**Controller Options**

**Teaching Pendant**

This is a teaching device that provides information on functions such as position input, running tests, and monitoring.

Item	RCM-E	RCM-P	CON-T-ENG	SEL-T-J	SEL-TD-J
Exterior dimensions					
Applicable controllers	PCON/ACON/RPCON/RACON			PSEL/ASEL	
Position input	○	○	○	○	○
Program input	-	-	-	○	○
Actuator operation	○	-	○	□	○
Display	16 characters x 2 lines, LCD display			20 characters x 4 lines, LCD display	
3 position enabling switch	-	-	- (*1)	-	○
Compatible with the ANSI standard	-	-	- (*1)	-	○
Compatible with the CE mark	-	-	○	○	○
Compatible with the UL standard	-	-	- (*1)	-	○
Cable length	5m				
Ambient operating temperature, humidity	0 to 40°C temperature, 85% RH or less				
Ingress Protection	-	-	IP54		
Mass	Approx. 400g	Approx. 360g	Approx. 400g	Approx. 400g	Approx. 400g

(\*1) Feature of CON-TG-S

**PC-compatible software (Windows only)**

**Feature**

A startup support software program offering program/position input function, test operation function, monitoring function, and more. The functions needed for debugging have been enhanced to help reduce the startup time.

**PC-compatible software for PCON/ACON/RPCON/RACON (for RS232 connection)**

Model **RCM-101-MW-EU** (comes with external device communication cable + RS232 conversion unit)

**Configuration**

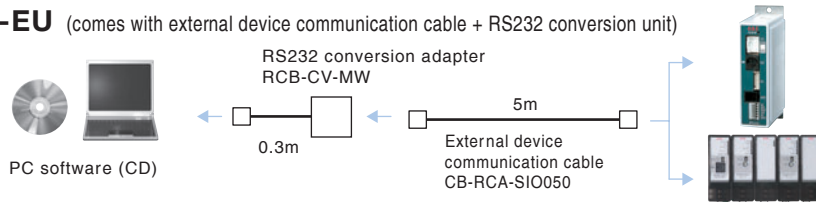

**PC-compatible software for PCON/ACON/RPCON/RACON (for USB connection)**

Model **RCM-101-USB-EU** (comes with external device communication cable + USB conversion adapter + USB cable)

**Configuration**

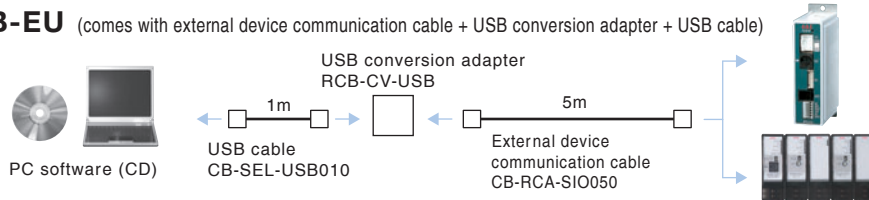

**PC-compatible software for PSEL/ASEL (for RS232 connection)**

Model **IA-101-X-MW-J** (comes with RS232C cable + connector conversion cable)

**Configuration**

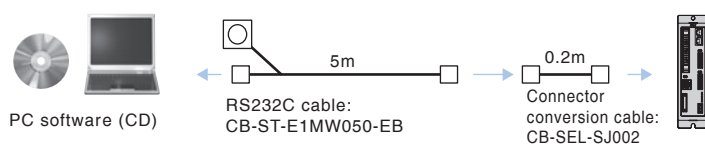

**PC-compatible software (for USB connection)**

Model **IA-101-X-USB** (for USB cable)

**Configuration**

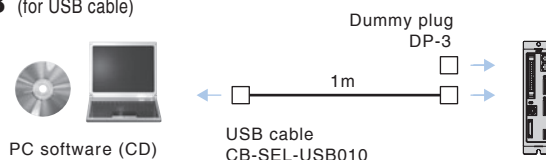

**RCP2&RCA-SRA4R Series  
Short Rod Type  
Catalogue No. 0209-E**

Errors excepted - the information contained in this catalogue is subject to change without notice for the pupose of product improvement



Providing quality products  
since 1986



**IAI Industrieroboter GmbH**  
Ober der Röth 4  
D-65824 Schwalbach / Frankfurt  
Germany  
Tel.:+49-6196-8895-0  
Fax:+49-6196-8895-24  
E-Mail: info@IAI-GmbH.de  
Internet: <http://www.eu.IAI-GmbH.de>

---

**IAI America, Inc.**  
2690 W. 237th Street  
Torrance, CA 90505, U.S.A.  
Phone: +1-310-891-6015  
Fax: +1-310-891-0815

**IAI (Shanghai) Co., Ltd.**  
Shanghai Jiahua B. C. A8404.808  
Hongqiao Rd., Shanghai 200030, China  
Phone: +86-21-6448-4753  
Fax: +86-21-6448-3992

**IAI CORPORATION**  
645-1 Shimizu Hirose  
Shizuoka 424-0102, Japan  
Phone: +81-543-64-5105  
Fax: +81-543-64-5182