

Low/Medium Push Force Rod Type
Pulse Press Models with Load Cell

RCP6 RRA4/6/7R-LCT

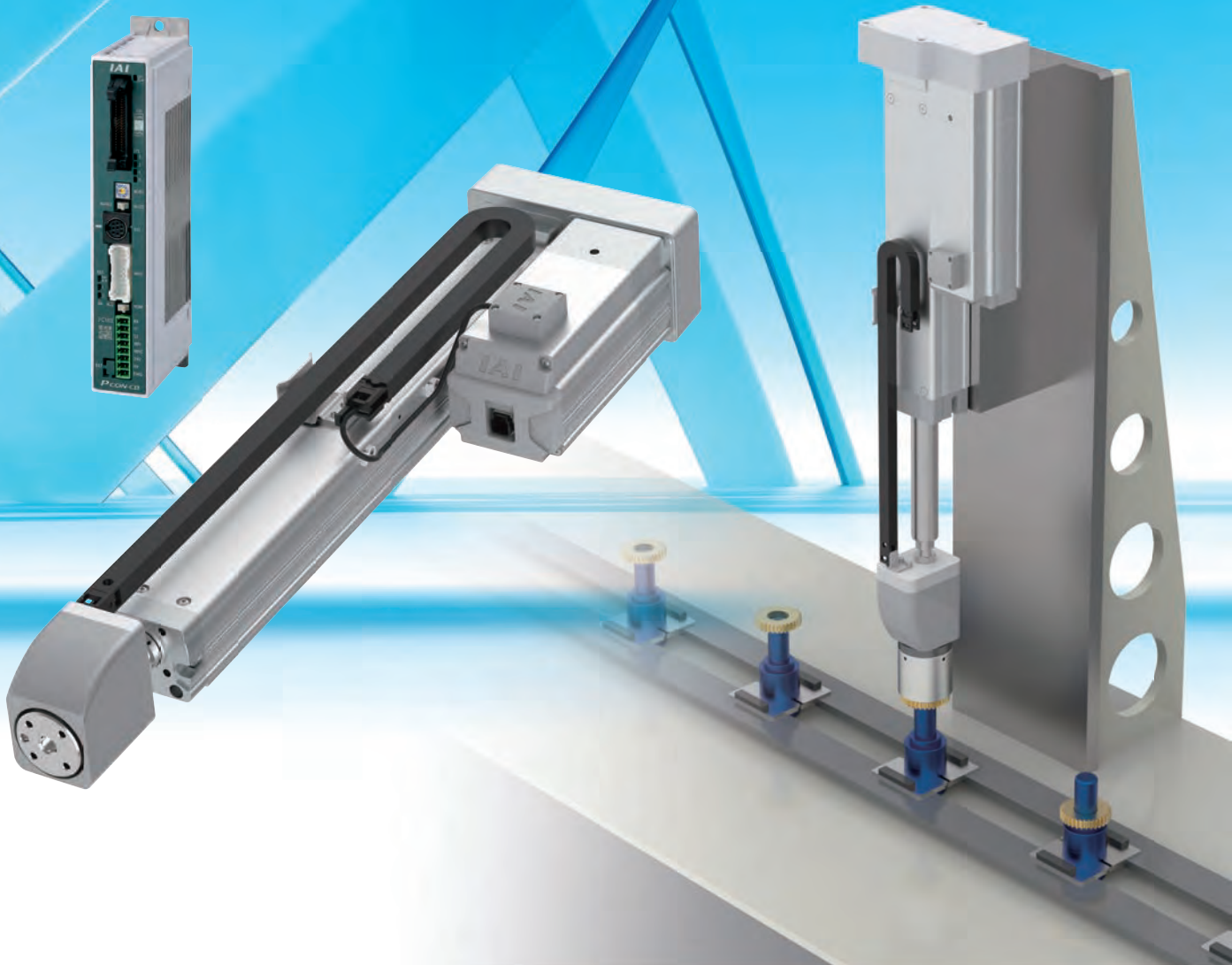

Actuator compatible with presses that allows for simple power control

IAI's new pulse press!

■ What is a pulse press?

A pulse press is an actuator combining a pulse motor and load cell, that is capable of performing power control. It provides a loading repeatability of $\pm 1.0\%$ F.S. (full scale), based on feedback from the load cell.



POINT

F.S. : Full Scale

Maximum measurable value

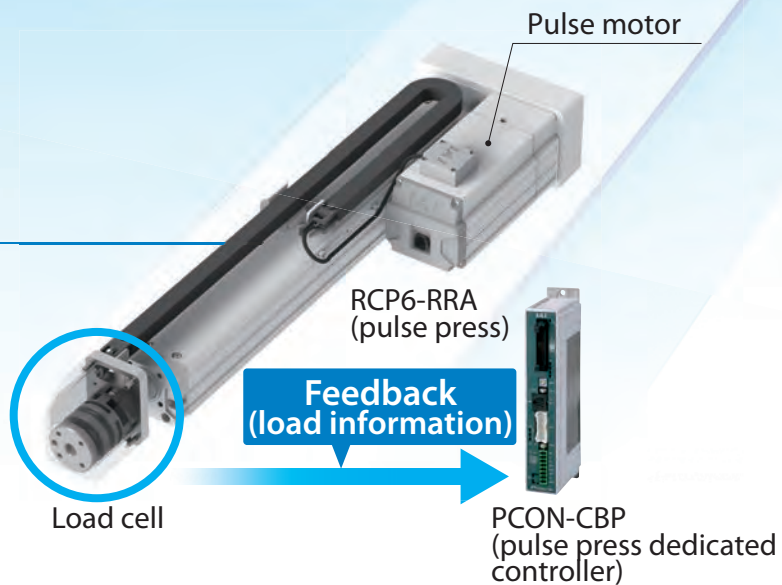

1

Capable of both pushing and pulling

Both pushing and pulling are supported in the load direction. There are no limitations on pushing or pulling times.

(Example) Washer press fitting (pushing)

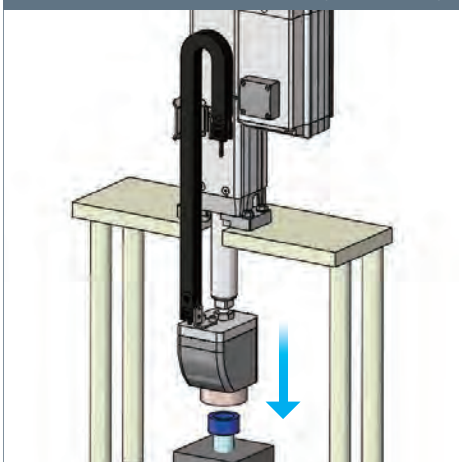

(Example) Wire harness pulling test

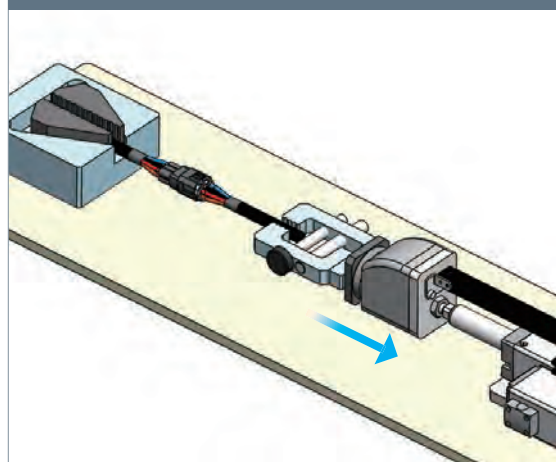



Example System for inspecting air leaks in sweet bread packaging

2 Reasonable cost

Equipped with a pulse motor, it is less than half the cost of an IAI servo press.

3 Lineup

Select from several types based on application (push force from 60N to 2000N).

RCP6-RR4R	60N~300N
RCP6-RR6R	60N~600N
RCP6-RR7R	200N~2000N

Easy setup using a dedicated tool

Pushing/pulling can easily be setup using the PC software or teaching pendant.

■ PC software (screenshot)

The screenshot shows two windows from the PC software. The 'Edit position data' window contains a table with the following data:

No.	Position [mm]	Speed [mm/s]	Acceleration [G]	Deceleration [G]	Operation type (push force [%])	Positioning band [mm] / push band [mm]	Stop position specification method
0							
1	0.00	200.00	0.50	0.50	Positioning	0.10	0: absolute position
2	50.00	200.00	0.30	0.30	Push (30%)	20.00	0: absolute position
3							
4							

Below the table, the 'Input range: 1 to 60' is shown, and a 'Converted value: 302 [N]' is displayed in a red box. The 'Operation type (push force [%])' dialog box is open, showing 'Push' selected. The 'Push Force' field is set to 30% and is highlighted with a red box, with a note indicating this equals 302[N]. The input range is also shown as 1 to 60.

■ Example of washer press fitting

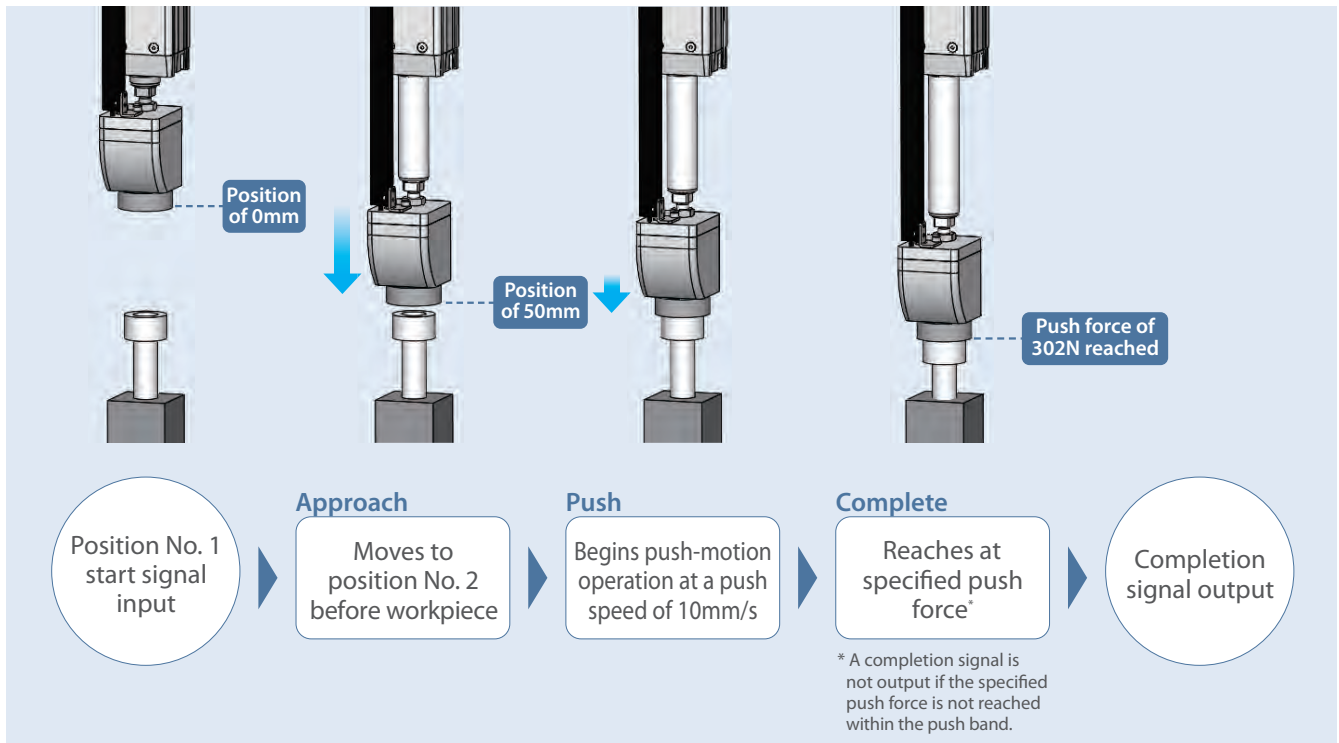

Model Specification Items

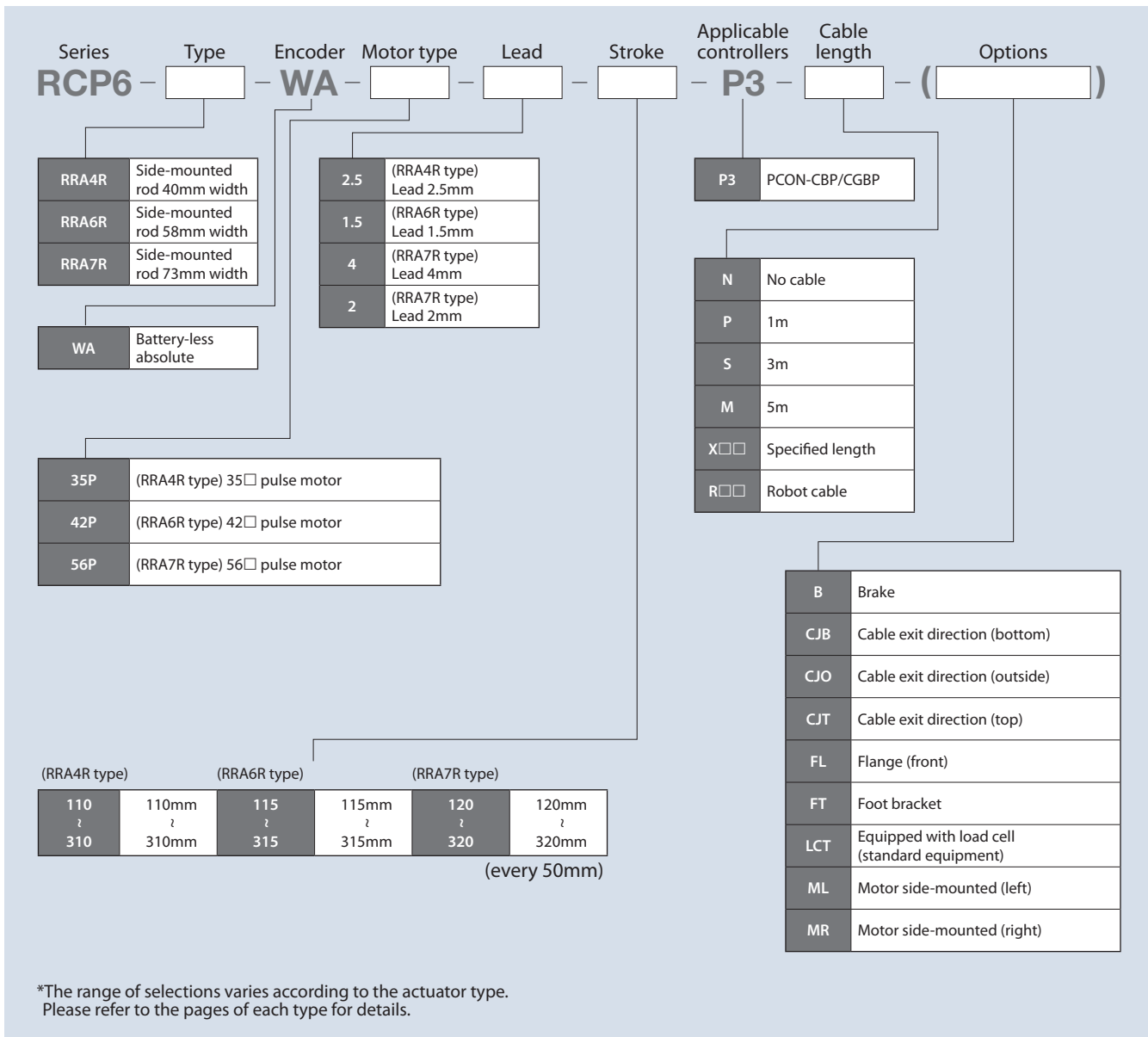

Specifications

Type	Stroke (mm) and max speed (mm/s)							Lead (mm)	Max. push/pull force (N)	Max. payload (kg)		Reference page
	* Length of band = Stroke *Numbers in band = Maximum speed by stroke									Horizontal	Vertical	
	110	115	120	- Stroke can be selected in 50mm increments -			310					
RRA4R	200							2.5	300	3	3	P5
RRA6R	110							1.5	600	10	10	P8
RRA7R	160							4	1000	10	10	P11
	85							2	2000	10	10	

RCP6-RAA4R

(Pulse press specification)



Model Specification Items

RCP6	RRA4R	WA	35P	2.5		P3		
Series	Type	Encoder type	Motor type	Lead	Stroke	Applicable controllers	Cable length	Options
		WA Battery-less absolute	35P Pulse motor 35□ size	2.5 2.5mm	110 110mm 310 310mm (every 50mm)	P3 PCON	N No cable P 1m S 3m M 5m X□ Specified length R□ Robot cable	Refer to the options table.

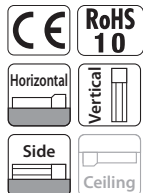

(Note) The figure above is the motor side-mounted to left (ML).

- POINT Selection Notes**
- (1) There are no limitations on the continuous push time or continuous pull time.
 - (2) Continuous operation is possible at a duty ratio of 100%.
 - (3) Pay close attention to the mounting method of the body. Please refer to P. 17 for details.
 - (4) Pay close attention to the mounting orientation. Please refer to P. 17 for details.
 - (5) Please refer to P. 17 for information on load cell.

Main Specifications

Item		Description	
Lead	Ball screw lead (mm)	2.5	
Horizontal	Payload	Maximum payload (kg) (high-output enabled)	3
		Maximum payload (kg) (high-output disabled)	3
	Speed / acceleration/ deceleration	Max. speed (mm/s)	200
		Rated acceleration/deceleration (G)	0.5
		Max. acceleration/deceleration (G)	0.5
Vertical	Payload	Maximum payload (kg) (high-output enabled)	3
		Maximum payload (kg) (high-output disabled)	3
	Speed / acceleration/ deceleration	Max. speed (mm/s)	200
		Rated acceleration/deceleration (G)	0.5
		Max. acceleration/deceleration (G)	0.5
Push	Max. push force (N)	300	
	Min. push force (N)	60	
	Max. push speed (mm/s)	10	
Pull	Max. pull force (N)	300	
	Min. pull force (N)	60	
	Max. pull speed (mm/s)	10	
Brake	Brake specification	Non-excitation actuating solenoid brake	
	Brake holding force (kg)	3	
Stroke	Min. stroke (mm)	110	
	Max. stroke (mm)	310	
	Stroke pitch (mm)	50	

Item	Description
Drive system	Ball screw, ø8mm, rolled C10
Positioning repeatability	±0.02mm
Lost motion	0.1mm or less
Load cell rated capacity	600N
Loading repeatability (Note 1)	±1.0% F.S. (Note 2)
Load cell accuracy	±1.0% R.C. (Note 3)
Ambient operating temperature, humidity	0 ~ 40°C, 85%RH or less (no condensation)
Degree of protection	IP20
Vibration & shock resistance	4.9m/s ²
Overseas standards	CE marking, RoHS directive
Motor type	Pulse motor
Encoder type	Battery-less absolute
Number of encoder pulses	8192 pulse/rev

(Note 1) Ratio (in percentage) of the load variations caused by the repeated operations to the load cell rated capacity.

(Note 2) F.S.: Full Scale, the maximum measurable value.

(Note 3) R.C.: Rated capacity.

Options

Name	Option code	Reference page
Brake (Note 1)	B	14
Cable exit direction (bottom) (Note 2)	CJB	14
Cable exit direction (outside)	CJO	14
Cable exit direction (top)	CJT	14
Flange (front) (Note 1)	FL	14
Foot bracket (Note 2, 3)	FT	15
Equipped with load cell (standard equipment) (Note 4)	LCT	15
Motor side-mounted (left) (Note 5)	ML	15
Motor side-mounted (right) (Note 5)	MR	15

(Note 1) Flange (front) (FL) cannot be selected when selecting brake (B) with a stroke of 110mm.
 (Note 2) Foot bracket (FT) cannot be selected when selecting cable exit direction (bottom) (CJB).
 (Note 3) Please refer to P. 15 for the number of brackets included.
 (Note 4) Be sure to enter in the option section of the model number.
 (Note 5) Be sure to enter a code in the option section of the model number.

Cable Length

Type	Cable code
Standard type	P (1m)
	S (3m)
	M (5m)
Specified length	X06 (6m) ~ X10 (10m)
	X11 (11m) ~ X15 (15m)
	X16 (16m) ~ X20 (20m)
	R01 (1m) ~ R03 (3m)
Robot cable	R04 (4m) ~ R05 (5m)
	R06 (6m) ~ R10 (10m)
	R11 (11m) ~ R15 (15m)
	R16 (16m) ~ R20 (20m)

Payload by Speed/Acceleration

■ **High-output setting enabled** (the unit for payload is kg)

Orientation	Horizontal	Vertical
	Acceleration (G)	
Speed (mm/s)	0.5	0.5
0	3	3
40	3	3
85	3	3
130	3	3
150	3	3
200	3	3

■ **High-output setting disabled** (the unit for payload is kg)

Orientation	Horizontal	Vertical
	Acceleration (G)	
Speed (mm/s)	0.5	0.5
0	3	3
40	3	3
85	3	3
130	3	3
150	3	3

Stroke and Max Speed

High-output setting	Stroke (mm)				
	110	160	210	260	310
Enabled	200				
Disabled	150				

(Unit: mm/s)

Correlation diagram between push force and push command value

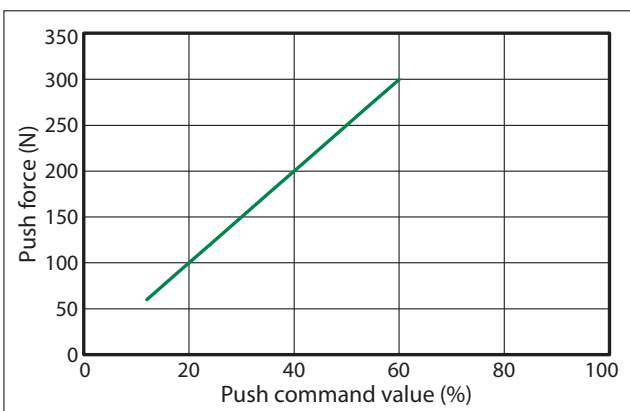

Correlation diagram between pull force and pull command value

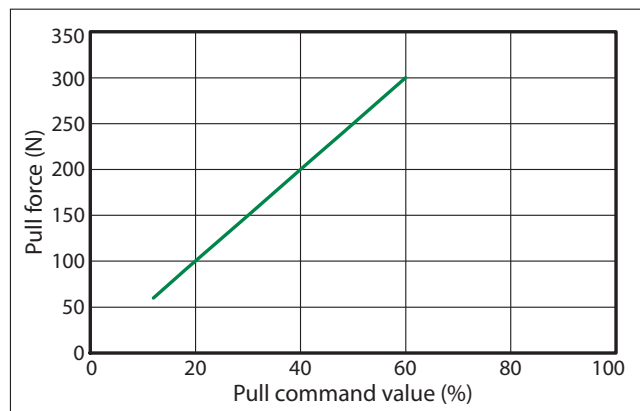

RCP6-RAA6R

(Pulse press specification)



Model Specification Items

RCP6	RAA6R	WA	42P	1.5		P3		
Series	Type	Encoder type	Motor type	Lead	Stroke	Applicable controllers	Cable length	Options
		WA Battery-less absolute	42P Pulse motor 42□ size	1.5 1.5mm	115 115mm 315 315mm (every 50mm)	P3 PCON	N No cable P 1m S 3m M 5m X□ Specified length R□ Robot cable	Refer to the options table.

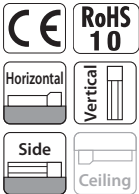

(Note) The figure above is the motor side-mounted to left (ML).

(1) There are no limitations on the continuous push time or continuous pull time.

(2) Continuous operation is possible at a duty ratio of 100%.

(3) Pay close attention to the mounting method of the body. Please refer to P. 17 for details.

(4) Pay close attention to the mounting orientation. Please refer to P. 17 for details.

(5) Please refer to P. 17 for information on load cell.

Main Specifications

	Item	Description	
Lead	Ball screw lead (mm)	1.5	
Horizontal	Payload	Maximum payload (kg) (high-output enabled)	10
		Maximum payload (kg) (high-output disabled)	10
	Speed / acceleration / deceleration	Max. speed (mm/s)	110
		Rated acceleration/deceleration (G)	0.3
		Max. acceleration/deceleration (G)	0.3
Vertical	Payload	Maximum payload (kg) (high-output enabled)	10
		Maximum payload (kg) (high-output disabled)	10
	Speed / acceleration / deceleration	Max. speed (mm/s)	110
		Rated acceleration/deceleration (G)	0.3
		Max. acceleration/deceleration (G)	0.3
Push		Max. push force (N)	600
		Min. push force (N)	60
		Max. push speed (mm/s)	10
Pull		Max. pull force (N)	600
		Min. pull force (N)	60
		Max. pull speed (mm/s)	10
Brake	Brake specification	Non-excitation actuating solenoid brake	
	Brake holding force (kg)	10	
Stroke	Min. stroke (mm)	115	
	Max. stroke (mm)	315	
	Stroke pitch (mm)	50	

Item	Description
Drive system	Ball screw, ø10mm, rolled C10
Positioning repeatability	±0.02mm
Lost motion	0.1mm or less
Load cell rated capacity	600N
Loading repeatability (Note 1)	±1.0% F.S. (Note 2)
Load cell accuracy	±1.0% R.C. (Note 3)
Ambient operating temperature, humidity	0 ~ 40°C, 85%RH or less (no condensation)
Degree of protection	IP20
Vibration & shock resistance	4.9m/s ²
Overseas standards	CE marking, RoHS directive
Motor type	Pulse motor
Encoder type	Battery-less absolute
Number of encoder pulses	8192 pulse/rev

(Note 1) Ratio (in percentage) of the load variations caused by the repeated operations to the load cell rated capacity.
 (Note 2) F.S.: Full Scale, the maximum measurable value.
 (Note 3) R.C.: Rated capacity.

Options

Name	Option code	Reference page
Brake	B	14
Cable exit direction (bottom) (Note 1)	CJB	14
Cable exit direction (outside)	CJO	14
Cable exit direction (top)	CJT	14
Flange (front)	FL	14
Foot bracket (Note 1, 2)	FT	15
Equipped with load cell (standard equipment) (Note 3)	LCT	15
Motor side-mounted (left) (Note 4)	ML	15
Motor side-mounted (right) (Note 4)	MR	15

(Note 1) Foot bracket (FT) cannot be selected when selecting cable exit direction (bottom) (CJB).

(Note 2) Please refer to P. 15 for the number of brackets included.

(Note 3) Be sure to enter in the option section of the model number.

(Note 4) Be sure to enter a code in the option section of the model number.

Cable Length

Type	Cable code
Standard type	P (1m)
	S (3m)
	M (5m)
Specified length	X06 (6m) ~ X10 (10m)
	X11 (11m) ~ X15 (15m)
	X16 (16m) ~ X20 (20m)
Robot cable	R01 (1m) ~ R03 (3m)
	R04 (4m) ~ R05 (5m)
	R06 (6m) ~ R10 (10m)
	R11 (11m) ~ R15 (15m)
	R16 (16m) ~ R20 (20m)

Payload by Speed/Acceleration

High-output setting enabled (the unit for payload is kg)

Orientation	Horizontal	Vertical
	Acceleration (G)	
Speed (mm/s)	0.3	0.3
0	10	10
35	10	10
70	10	10
100	10	10
110	10	10

High-output setting disabled (the unit for payload is kg)

Orientation	Horizontal	Vertical
	Acceleration (G)	
Speed (mm/s)	0.3	0.3
0	10	10
35	10	10
80	10	10

Stroke and Max Speed

High-output setting	Stroke (mm)				
	115	165	215	265	315
Enabled	110				
Disabled	80				

(Unit: mm/s)

Correlation diagram between push force and push command value

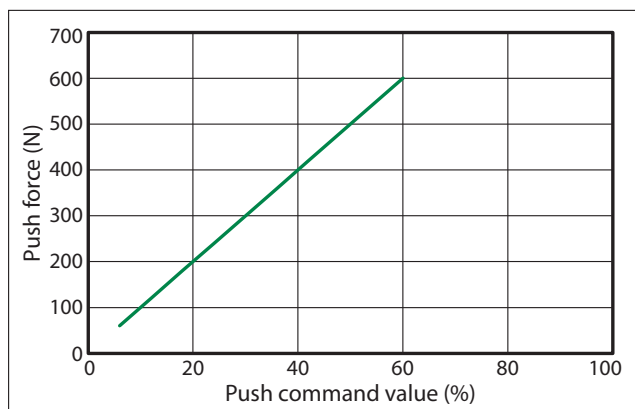

Correlation diagram between pull force and pull command value

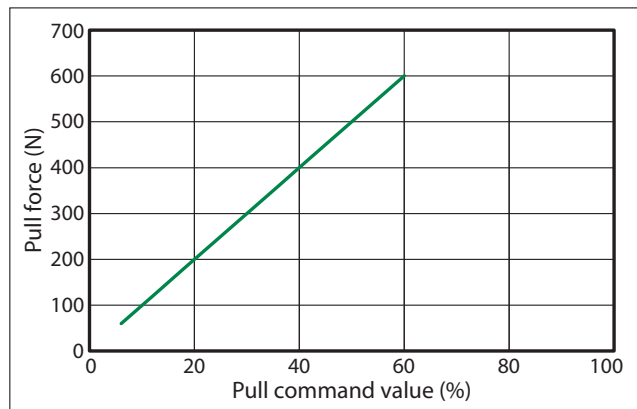

Dimensions

CAD drawings can be downloaded from our website.
www.iai-automation.com



(Note) When returning to the home position, the rod will move to the M.E. Be careful of interference with surrounding objects.

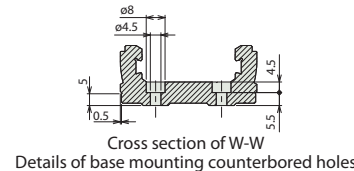
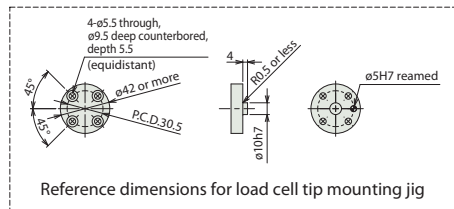
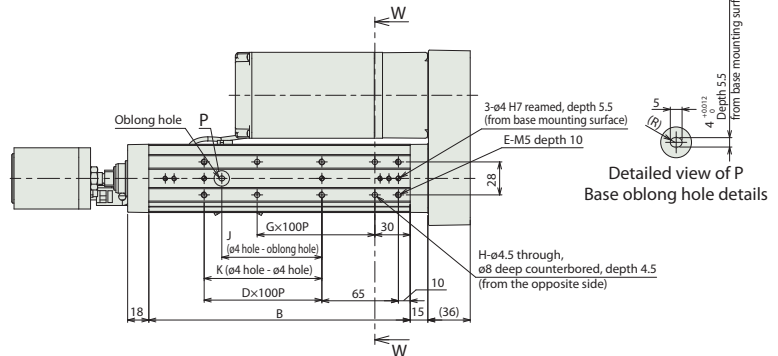
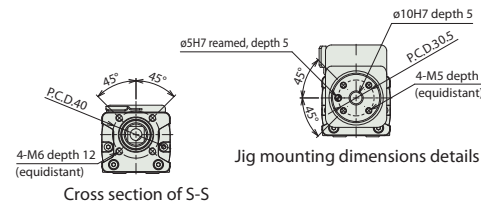
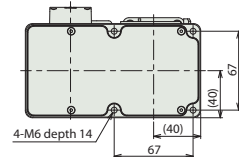
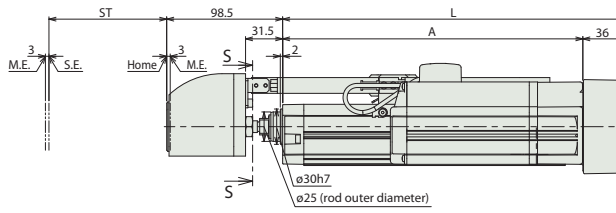
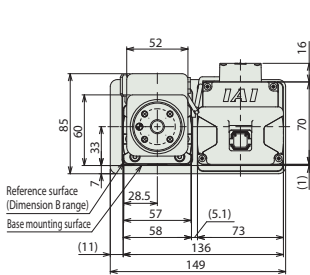
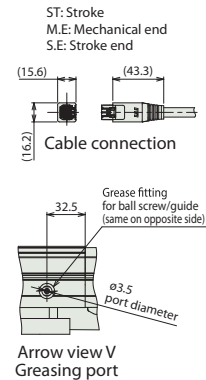
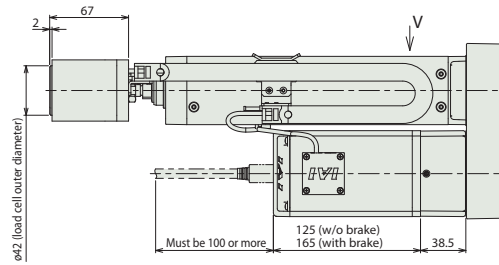
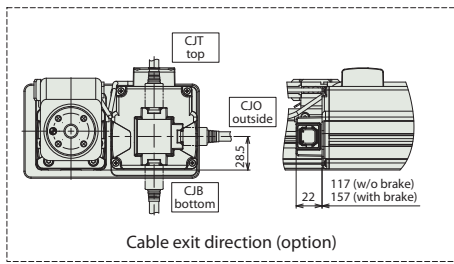

■ Dimensions by stroke

Stroke	115	165	215	265	315
L	291	341	391	441	491
A	255	305	355	405	455
B	222	272	322	372	422
D	1	1	2	2	3
E	6	6	8	8	10
G	1	2	2	3	3
H	4	6	6	8	8
J	85	85	185	185	285
K	100	100	200	200	300

■ Mass by stroke

Stroke	115	165	215	265	315
Mass (kg)	Without brake	4.0	4.2	4.5	4.9
	With brake	4.2	4.4	4.6	4.9

Applicable Controllers

The actuators on this page can be operated by the controllers indicated below. Please select the type depending on your intended use.

Name	External view	Maximum number of connectable axes	Power supply voltage	Control method											Maximum number of positioning points	Reference page				
				Positioner	Pulse-train	Program	Network (*Option)													
PCON-CBP/ CGBP		1	24VDC	●	-	-	●	●	●	●	●	-	-	●	●	●	-	-	512 (768 for network spec.)	18

(Note) Please refer to P. 19 for information on network abbreviation codes such as DV and CC.

RCP6-RAA7R

(Pulse press specification)

Battery-less Absolute

Side-mounted Motor

Body Width 70 mm

24v Pulse Motor

Model Specification Items

RCP6	RRA7R	WA	56P			P3		
Series	Type	Encoder type	Motor type	Lead	Stroke	Applicable controllers	Cable length	Options
		WA Battery-less absolute	56P Pulse motor 56□ size	4 4mm 2 2mm	120 120mm 320 320mm (every 50mm)	P3 PCON	N No cable P 1m S 3m M 5m X□ Specified length R□ Robot cable	Refer to the options table.

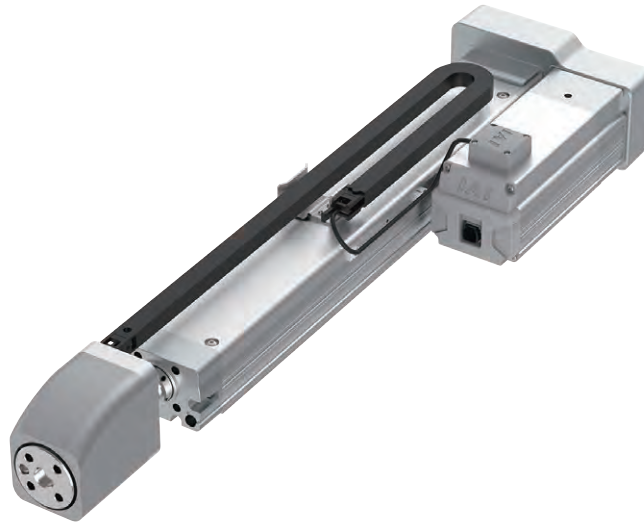
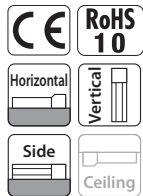

(Note) The figure above is the motor side-mounted to left (ML).

POINT

Selection Notes

(1) There are no limitations on the continuous push time or continuous pull time.

(2) Continuous operation is possible at a duty ratio of 100%.

(3) Pay close attention to the mounting method of the body. Please refer to P. 17 for details.

(4) Pay close attention to the mounting orientation. Please refer to P. 17 for details.

(5) Please refer to P. 17 for information on load cell.

Main Specifications

		Item	Description	
Lead		Ball screw lead (mm)	4	2
Horizontal	Payload	Maximum payload (kg) (high-output enabled)	10	10
		Maximum payload (kg) (high-output disabled)	10	10
	Speed / acceleration / deceleration	Max. speed (mm/s)	160	85
		Rated acceleration/deceleration (G)	0.3	0.3
		Max. acceleration/deceleration (G)	0.3	0.3
Vertical	Payload	Maximum payload (kg) (high-output enabled)	10	10
		Maximum payload (kg) (high-output disabled)	10	10
	Speed / acceleration / deceleration	Max. speed (mm/s)	160	85
		Rated acceleration/deceleration (G)	0.3	0.3
		Max. acceleration/deceleration (G)	0.3	0.3
Push		Max. push force (N)	1000	2000
		Min. push force (N)	200	200
		Max. push speed (mm/s)	10	10
Pull		Max. pull force (N)	1000	2000
		Min. pull force (N)	200	200
		Max. pull speed (mm/s)	10	10
Brake		Brake specification	Non-excitation actuating solenoid brake	
		Brake holding force (kg)	10	10
Stroke		Min. stroke (mm)	120	120
		Max. stroke (mm)	320	320
		Stroke pitch (mm)	50	50

Item	Description
Drive system	Ball screw, ø12mm, rolled C10
Positioning repeatability	±0.02mm
Lost motion	0.1mm or less
Load cell rated capacity	2000N
Loading repeatability (Note 1)	±1.0% F.S. (Note 2)
Load cell accuracy	±1.0% R.C. (Note 3)
Ambient operating temperature, humidity	0 ~ 40°C, 85%RH or less (no condensation)
Degree of protection	IP20
Vibration & shock resistance	4.9m/s ²
Overseas standards	CE marking, RoHS directive
Motor type	Pulse motor
Encoder type	Battery-less absolute
Number of encoder pulses	8192 pulse/rev

(Note 1) Ratio (in percentage) of the load variations caused by the repeated operations to the load cell rated capacity.

(Note 2) F.S.: Full Scale, the maximum measurable value.

(Note 3) R.C.: Rated capacity.

Options

Name	Option code	Reference page
Brake	B	14
Cable exit direction (bottom) (Note 1)	CJB	14
Cable exit direction (outside)	CJO	14
Cable exit direction (top)	CJT	14
Flange (front)	FL	14
Foot bracket (Note 1, 2)	FT	15
Equipped with load cell (standard equipment) (Note 3)	LCT	15
Motor side-mounted (left) (Note 4)	ML	15
Motor side-mounted (right) (Note 4)	MR	15

(Note 1) Foot bracket (FT) cannot be selected when selecting cable exit direction (bottom) (CJB).

(Note 2) Please refer to P. 15 for the number of brackets included.

(Note 3) Be sure to enter in the option section of the model number.

(Note 4) Be sure to enter a code in the option section of the model number.

Cable Length

Type	Cable code
Standard type	P (1m)
	S (3m)
	M (5m)
Specified length	X06 (6m) ~ X10 (10m)
	X11 (11m) ~ X15 (15m)
	X16 (16m) ~ X20 (20m)
Robot cable	R01 (1m) ~ R03 (3m)
	R04 (4m) ~ R05 (5m)
	R06 (6m) ~ R10 (10m)
	R11 (11m) ~ R15 (15m)
	R16 (16m) ~ R20 (20m)

Payload by Speed/Acceleration

■ **High-output setting enabled** (the unit for payload is kg)

Lead 4 (1000N)

Orientation	Horizontal	Vertical
	Acceleration (G)	
Speed (mm/s)	0.3	0.3
0	10	10
35	10	10
70	10	10
115	10	10
160	10	10

Lead 2 (2000N)

Orientation	Horizontal	Vertical
	Acceleration (G)	
Speed (mm/s)	0.3	0.3
0	10	10
35	10	10
70	10	10
85	10	10

■ **High-output setting disabled** (the unit for payload is kg)

Lead 4 (1000N)

Orientation	Horizontal	Vertical
	Acceleration (G)	
Speed (mm/s)	0.3	0.3
0	10	10
35	10	10
70	10	10
115	10	10

Lead 2 (2000N)

Orientation	Horizontal	Vertical
	Acceleration (G)	
Speed (mm/s)	0.3	0.3
0	10	10
35	10	10
60	10	10

Stroke and Max Speed

Lead (mm)	Push force Pull force	High-output setting	Stroke (mm)				
			120	170	220	270	320
4	1000N	Enabled	160				
		Disabled	115				
2	2000N	Enabled	85				
		Disabled	60				

(Unit: mm/s)

Correlation diagram between push force and push command value

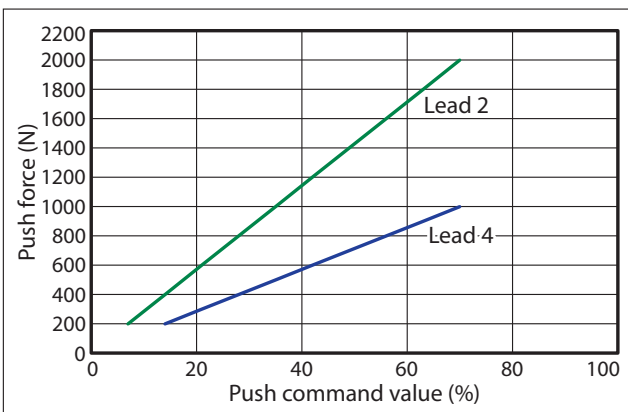

Correlation diagram between pull force and pull command value

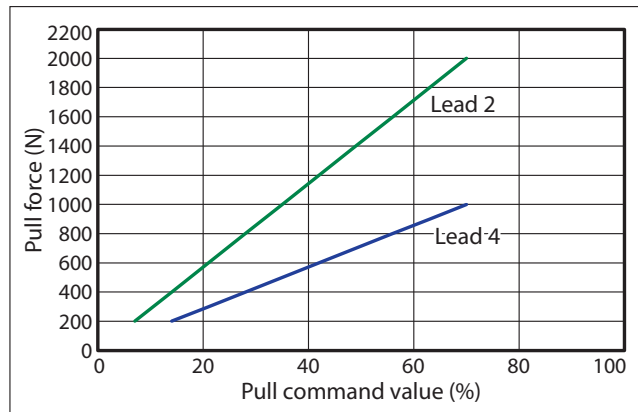

Options

Brake

Model B**Description** When the actuator is mounted vertically, this works as a holding mechanism that prevents the rod from falling and damaging any attachments when the power or servo is turned off.

Cable exit direction

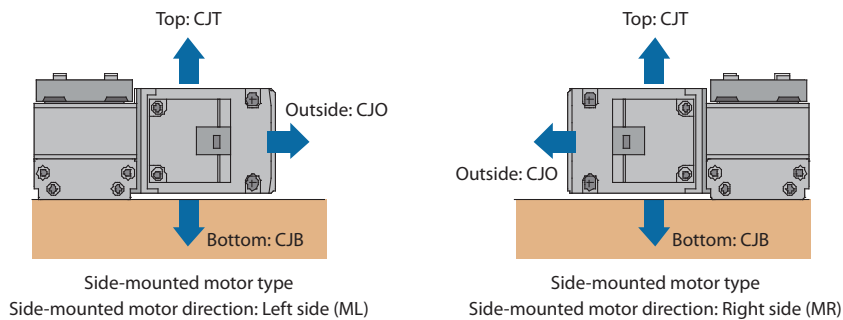
Model CJT / CJB / CJO**Description** This option allows to change the exit direction of the motor-encoder cable to top, bottom, or outside.

Flange (front)

Model FL**Description** This bracket is used for mounting the actuator body with bolts.

RCP6-RAA4R (LCT)

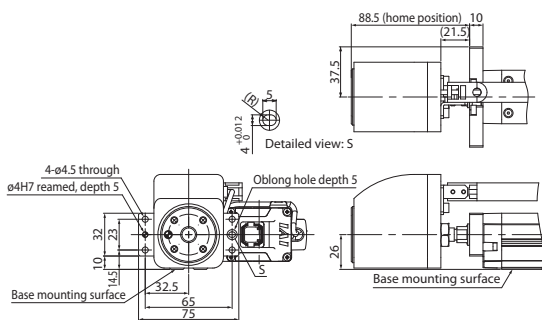
Single unit model number: RCP6L-FL-RAA4 (Note 1)
(Single unit weight: 0.14kg / Material: Steel)

RCP6-RAA6R (LCT)

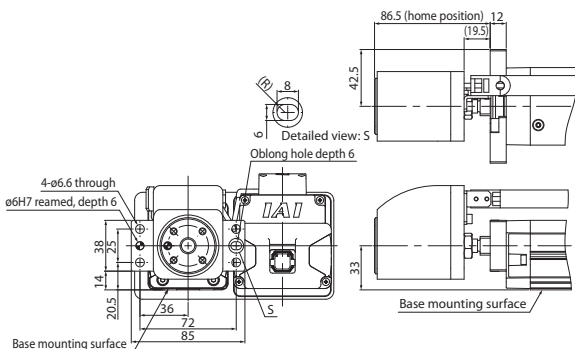
Single unit model number: RCP6L-FL-RAA6 (Note 1)
(Single unit weight: 0.20kg / Material: Steel)

RCP6-RAA7R (LCT)

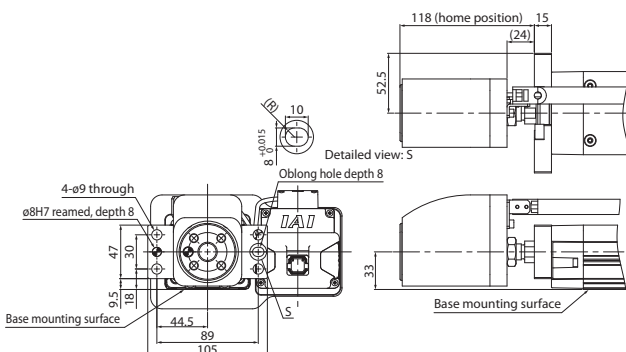
Single unit model number: RCP6L-FL-RAA7 (Note 1)
(Single unit weight: 0.36kg / Material: Steel)

(Note 1) 4 hex socket bolts enclosed

Foot bracket

Model FT

Description This bracket is used for mounting the actuator body from the top with bolts. The actuator body may be twisted or deformed if an insufficient number of mounting foot brackets is used. Actuator life could also be shortened.

* Refer to the installation dimensions in the actuator drawing for the installation pitch between the foot brackets.

RCP6-RAA4R
Single unit model number: RCS3-FT-RA4-2 (Note 1)

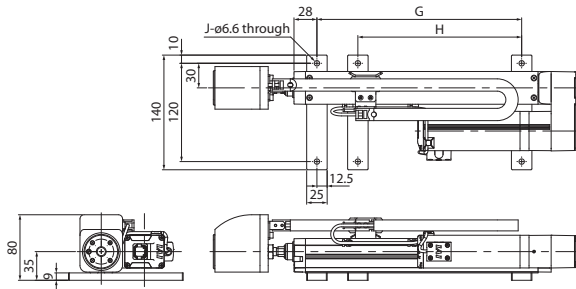

ST	G	H	J	"FT" selected as option	
				No. of foot brackets	Number of hex socket bolts enclosed
110	150	0	4	2	4
160	200	0	4	2	4
210	250	200	6	3	6
260	300	200	6	3	6
310	350	200	6	3	6

RCP6-RAA6R
Single unit model number: RCS3-FT-RA6-2 (Note 1)

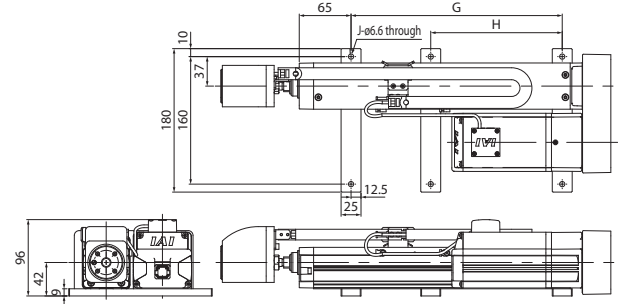

ST	G	H	J	"FT" selected as option	
				No. of foot brackets	Number of hex socket bolts enclosed
115	165	0	4	2	4
165	165	0	4	2	4
215	265	165	6	3	6
265	265	165	6	3	6
315	365	165	6	3	6

RCP6-RAA7R
Single unit model number: RCS3-FT-RA7-2 (Note 1)

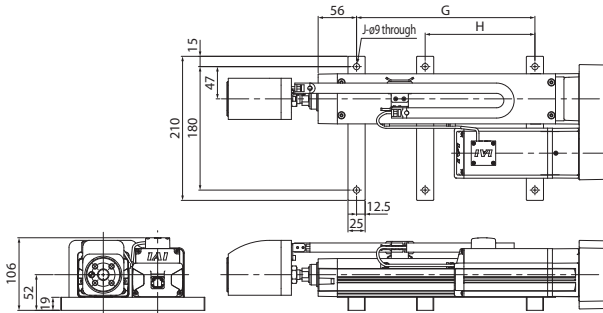

ST	G	H	J	"FT" selected as option	
				No. of foot brackets	Number of hex socket bolts enclosed
120	160	0	4	2	4
170	160	0	4	2	4
220	260	160	6	3	6
270	260	160	6	3	6
320	360	160	6	3	6

(Note 1) 2 hex socket bolts enclosed

Equipped with load cell

Model LCT

Description This option installs a load cell to the rod tip for operating with force control. *LCT must be selected for pulse press.

Side-mounted motor direction

Model ML / MR

Description This code is for specifying the direction of the side-mounted motor. Side-mounted to left is ML and right is MR.

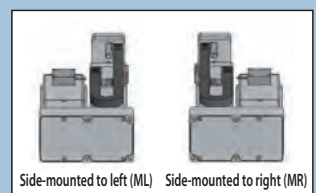

Maintenance parts

Maintenance part schematics

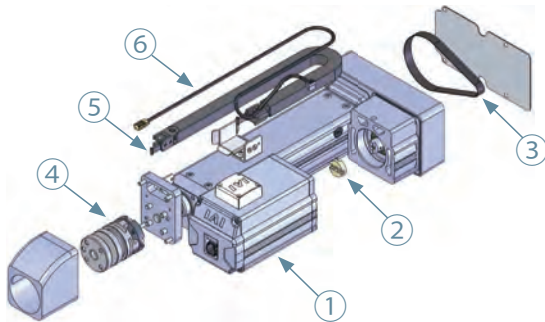

- ① Motor unit
- ② Coupling spacer
- ③ Timing belt
- ④ Load cell unit
- ⑤ Cable track assembly
- ⑥ Load cell cable assembly

* Please refer to the direction and dimensions on the product pages when selecting the cable exit direction option.

Maintenance part model list

The numbers at the tables match the numbers in the schematics.

① Motor unit

Type	Motor side-mounted direction	Cable exit direction	Model	
			Without brake	With brake
RRA4R	Left/right same	Not specified	RCP6-MUPP4R	RCP6-MUPP4R-B
		Bottom	RCP6-MUPP4R-CJB-ML	RCP6-MUPP4R-B-CJB-ML
		Outside	RCP6-MUPP4R-CJO-ML	RCP6-MUPP4R-B-CJO-ML
	Left side	Top	RCP6-MUPP4R-CJT-ML	RCP6-MUPP4R-B-CJT-ML
		Bottom	RCP6-MUPP4R-CJB-MR	RCP6-MUPP4R-B-CJB-MR
		Outside	RCP6-MUPP4R-CJO-MR	RCP6-MUPP4R-B-CJO-MR
Right side	Top	RCP6-MUPP4R-CJT-MR	RCP6-MUPP4R-B-CJT-MR	
	Not specified	RCP6-MUPP6R-ML	RCP6-MUPP6R-B-ML	
	Bottom	RCP6-MUPP6R-CJB-ML	RCP6-MUPP6R-B-CJB-ML	
RRA6R	Left side	Outside	RCP6-MUPP6R-CJO-ML	RCP6-MUPP6R-B-CJO-ML
		Top	RCP6-MUPP6R-CJT-ML	RCP6-MUPP6R-B-CJT-ML
		Not specified	RCP6-MUPP6R-MR	RCP6-MUPP6R-B-MR
	Right side	Bottom	RCP6-MUPP6R-CJB-MR	RCP6-MUPP6R-B-CJB-MR
		Outside	RCP6-MUPP6R-CJO-MR	RCP6-MUPP6R-B-CJO-MR
		Top	RCP6-MUPP6R-CJT-MR	RCP6-MUPP6R-B-CJT-MR
RRA7R	Left side	Not specified	RCP6-MUPP7R-ML	RCP6-MUPP7R-B-ML
		Bottom	RCP6-MUPP7R-CJB-ML	RCP6-MUPP7R-B-CJB-ML
		Outside	RCP6-MUPP7R-CJO-ML	RCP6-MUPP7R-B-CJO-ML
		Top	RCP6-MUPP7R-CJT-ML	RCP6-MUPP7R-B-CJT-ML
	Right side	Not specified	RCP6-MUPP7R-MR	RCP6-MUPP7R-B-MR
		Bottom	RCP6-MUPP7R-CJB-MR	RCP6-MUPP7R-B-CJB-MR
		Outside	RCP6-MUPP7R-CJO-MR	RCP6-MUPP7R-B-CJO-MR
		Top	RCP6-MUPP7R-CJT-MR	RCP6-MUPP7R-B-CJT-MR

② Coupling spacer

Type	Model
RRA4R	CPG-RCP6-S
RRA6R	
RRA7R	CPG-RCP6-M

③ Timing belt

Type	Model
RRA4R	TB-RCS3-RA4R
RRA6R	TB-RCS3-RA6R
RRA7R	TB-RCS3-RA7R

④ Load cell unit

Type	Model
RRA4R	K-TIAI/600N1-1-PT
RRA6R	
RRA7R	K-TIAI/2KN1-1-PT

⑤ Cable track assembly

Type	Stroke	Model
RRA4R	110mm	CVR-P6PP-16
	160mm	CVR-P6PP-18
	210mm	CVR-P6PP-23
	260mm	CVR-P6PP-28
	310mm	CVR-P6PP-31
RRA6R	115mm	CVR-P6PP-18
	165mm	
	215mm	CVR-P6PP-23
	265mm	CVR-P6PP-28
	315mm	CVR-P6PP-33
RRA7R	120mm	CVR-P6PP-18
	170mm	CVR-P6PP-23
	220mm	
	270mm	CVR-P6PP-28
	320mm	CVR-P6PP-33

⑥ Load cell cable assembly

Type	Stroke	Model
RRA4R	110mm	CB-P6PP-LDC006
	160mm	CB-P6PP-LDC007
	210mm	CB-P6PP-LDC008
	260mm	CB-P6PP-LDC009
	310mm	CB-P6PP-LDC010
RRA6R	115mm	CB-P6PP-LDC006
	165mm	CB-P6PP-LDC007
	215mm	CB-P6PP-LDC008
	265mm	CB-P6PP-LDC009
	315mm	CB-P6PP-LDC010
RRA7R	120mm	CB-P6PP-LDC006
	170mm	CB-P6PP-LDC008
	220mm	
	270mm	CB-P6PP-LDC009
	320mm	CB-P6PP-LDC010

Mounting orientation and load cell handling precautions

Mounting orientation

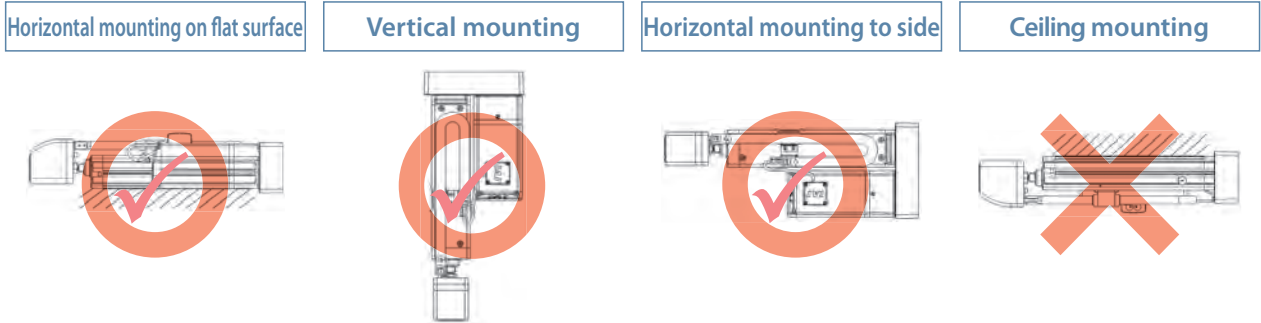

- Keep the flatness of body installation surface and workpiece mounting surface at 0.05mm/m or lower. Uneven flatness will increase the sliding resistance of the slider and may cause a malfunction.

Precautions for installation

Keep the following in mind when using a screw hole or foot bracket to fix in place.

- 1 Do not attempt to apply any external force to the body of RoboCylinder. External force may cause malfunctions or damage to parts.

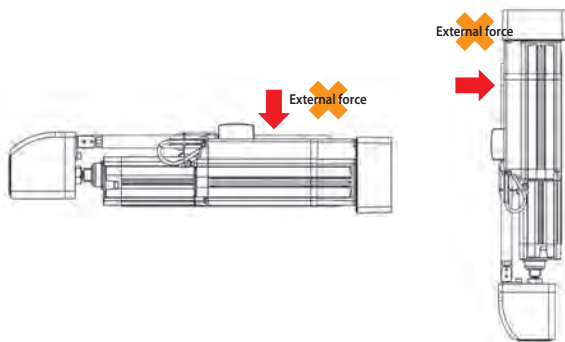

- 2 Prepare a support block as shown in the figure below when not using the base mounting surface for horizontal mounting, even if there is no external force applied on the body.

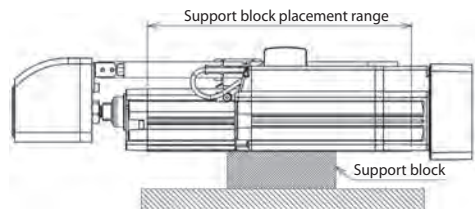

Load cell handling precautions

- Never push/pull operation in the positioning mode. This will damage the load cell.
- Use with a jig mounted to the load cell.

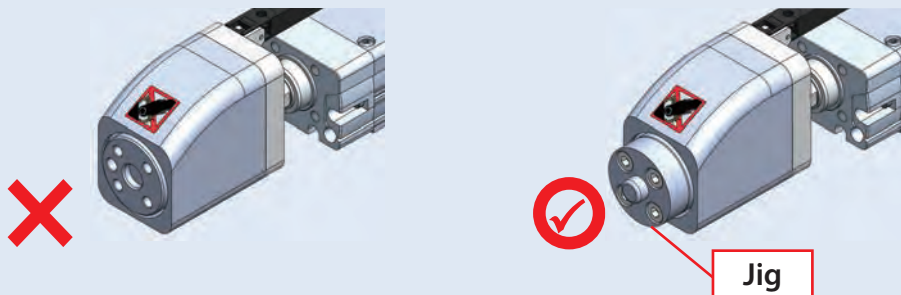

- Do not apply a radial load or moment load to the body of the load cell.
- Do not apply a shock exceeding the specified value due to collisions etc. to the body of the load cell. Be especially careful not to mistakenly apply a shock to the load cell during mounting.
- Be careful not to hold the product by the load cell when transporting it.
- The load cell must be periodically calibrated. Please refer to the instruction manual for information on calibration.

PCON-CBP

Pulse press dedicated controller



Features

1 High resolution battery-less absolute encoder support

Pulse press specification actuators are equipped with high resolution battery-less absolute encoders. As no battery is needed for retaining position data, it is possible to save space around the control panel, which helps to keep down the cost of the equipment.



2 Supports force control using a load cell

The current load value can be read from the load cell. Both load directions for pushing and pulling are supported, and can be easily switched out by specifying position data.

3 Display in N unit support for target loads

Position data **Push (%)** is displayed as converted **Target load (N)**.
If the collision detection function is disabled, converted "N" value is also displayed for the **Threshold (%)**.

[PC software]

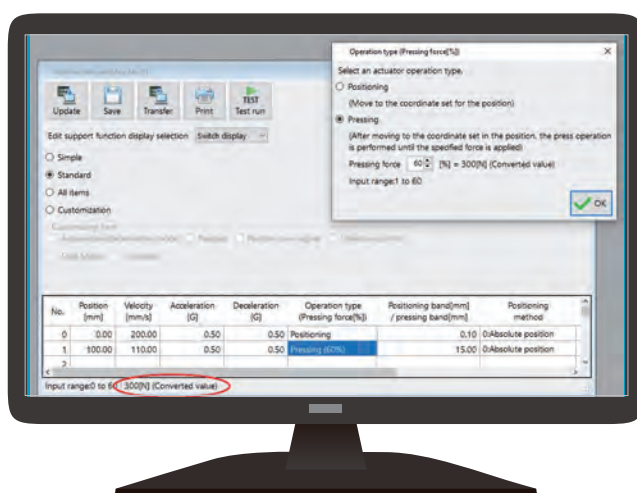





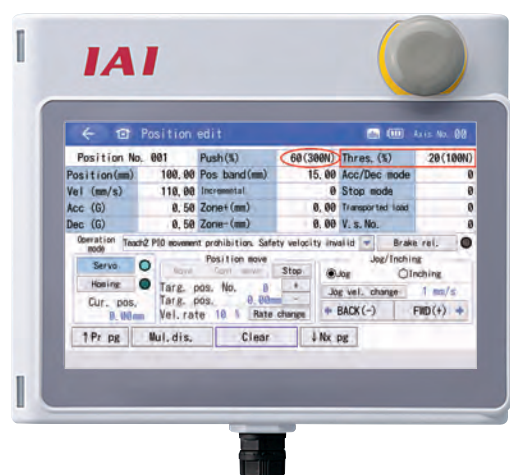



IA-OS: Position editing screen

[Teaching pendant]



TB-02: Position editing screen

List of Models

Model	PCON-CBP/CGBP									
External view										
I/O type	Positioner type	Field network type								
		 DeviceNet DeviceNet specification	 CC-Link CC-Link specification	 CC-Link IE Field CC-Link IE Field specification	 PROFIBUS-DP PROFIBUS-DP specification	 CompoNet CompoNet specification	—	 EtherCAT EtherCAT specification	 EtherNet/IP EtherNet/IP specification	 PROFINET IO PROFINET IO specification
I/O type model number	NP/PN	DV	CC	CIE	PR	CN	—	EC	EP	PRT
Supported encoder	High-resolution batteryless absolute									

Model Specification Items

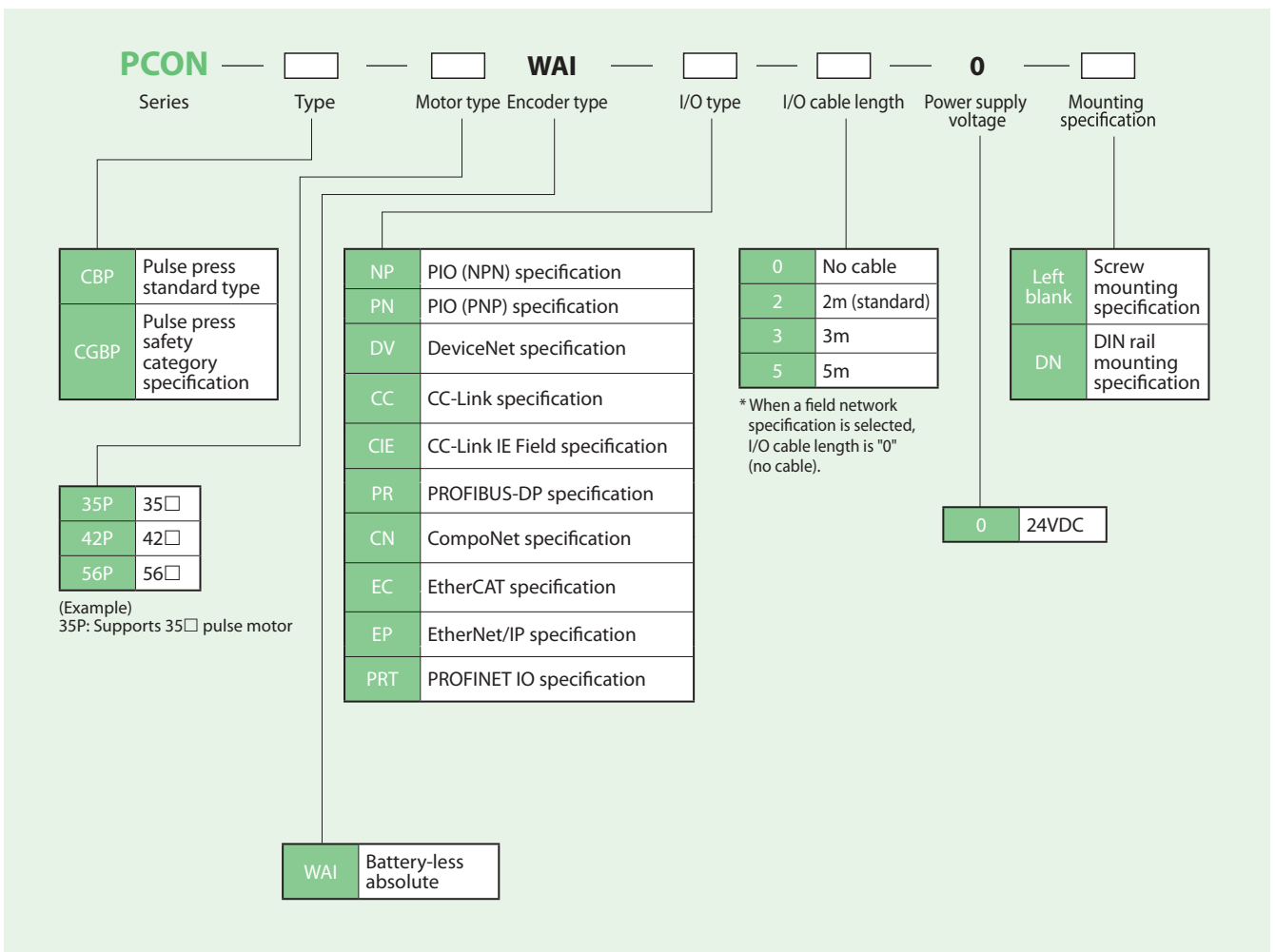

System Configuration

Option

PC software
(See P. 26)

Software only
<Model: IA-OS>

Dedicated connection
cable included
<Model: IA-OS-C>

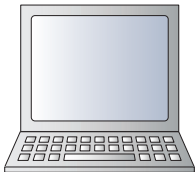

Dedicated connection cable

Option

Touch panel teaching
pendant
(See P. 26)

<Model: TB-02-□>



* Please contact IAI for the current supported versions.

5m



Supplied with actuator

Motor/encoder cable
Motor/encoder robot cable

These items will be supplied if the cable length is specified in the actuator model name.

Please refer to last page for the maintenance cable

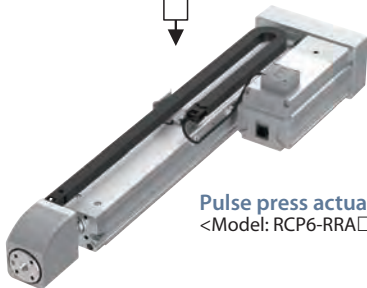

Pulse press actuator
<Model: RCP6-RRA□>



Field network

DeviceNet/CC-Link/CC-Link IE Field/PROFIBUS-DP/
CompoNet/EtherCAT/EtherNet/IP/PROFINET IO

Supplied with controller for
PIO specification

PIO cable
(See last page)

<Model: CB-PAC-PIO020>
Standard 2m



Controller

<Model: PCON-CBP/CGBP>



Option

24VDC power
supply

* Coming soon.
(See P. 26)

<Model: PSA-24>

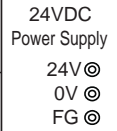

24VDC Power
supply

* Can be provided
by the customer.



Supplied with PCON-CGBP

Dummy plug
(See P. 26)

<Model: DP-5>

PIO I/O Interface

■ **Input** External input specification

Item	Specification
Input voltage	24VDC ±10%
Input current	5mA, 1 circuit
ON/OFF voltage	ON voltage: 18VDC min. OFF voltage: 6VDC max.

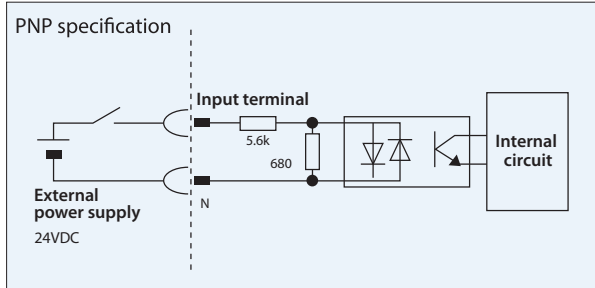
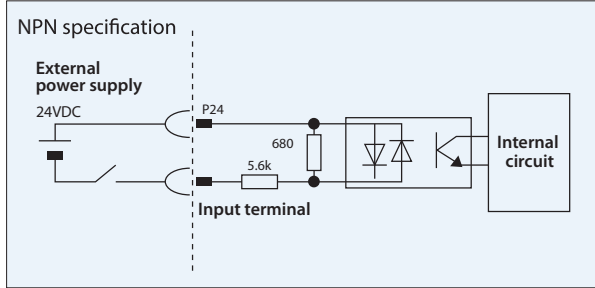

■ **Output** External output specification

Item	Specification
Load voltage	24VDC
Maximum load current	50mA, 1 circuit
Leakage current	2mA max./point

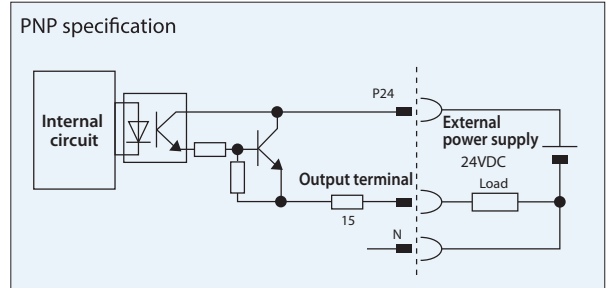
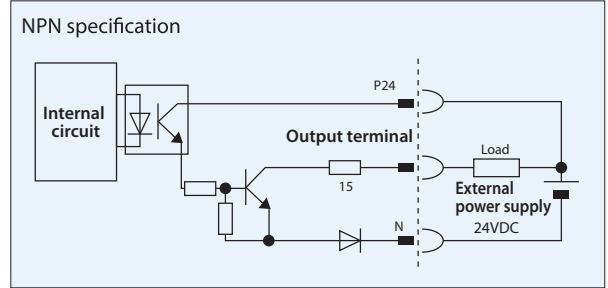

Types of PIO Patterns (Control Patterns)

This controller has 8 types of control methods.

Please set the PIO pattern that best suits your application in Parameter No.25, "PIO Pattern Selection."

Type	Set value of parameter No.25	Mode	Overview
PIO pattern 0	0 (factory setting)	Positioning mode (standard type)	<ul style="list-style-type: none"> Number of positioning points: 64 points Zone signal output ¹: 1 point Position number command: Binary code Position zone signal output ²: 1 point
PIO pattern 1	1	Teaching mode (teaching type)	<ul style="list-style-type: none"> Number of positioning points: 64 points Position zone signal output ²: 1 point Jog (inching) operation using PIO signals is supported. Current position data can be written to the position table using PIO signals.
PIO pattern 2	2	256-point mode (256 positioning points type)	<ul style="list-style-type: none"> Number of positioning points: 256 points Position number command: Binary code Position zone signal output ²: 1 point
PIO pattern 3	3	512-point mode (512 positioning points type)	<ul style="list-style-type: none"> Number of positioning points: 512 points Position number command: Binary code No zone signal output
PIO pattern 4	4	Solenoid valve mode 1 (7-point type)	<ul style="list-style-type: none"> Number of positioning points: 7 points Zone signal output ¹: 1 point Position number command: Individual number signal ON Position zone signal output ²: 1 point
PIO pattern 5	5	Solenoid valve mode 2 (3-point type)	<ul style="list-style-type: none"> Number of positioning points: 3 points Completion signal: A signal equivalent to a LS (limit switch) signal can be output. Zone signal output ¹: 1 point Position number command: Individual number signal ON Position zone signal output ²: 1 point
PIO pattern 6	6	Force control mode 1	<ul style="list-style-type: none"> Number of positioning points: 32 points Position zone signal output ²: 1 point Load cell calibration command Position number command: Binary code
PIO pattern 7	7	Force control mode 2	<ul style="list-style-type: none"> Number of positioning points: 5 points Position zone signal output ²: 1 point Load cell calibration command Position number command: Individual number signal ON

¹ Zone signal output: Please set the desired zone range in Parameter No.1/2 or 23/24. It will remain enabled once home return is completed.

² Position zone signal output: This command function relates to the position number. Set the desired zone range in the position table. This function will only become enabled when the corresponding position is specified. It will be disabled for all other positions.

PIO Patterns and Signal Assignments

The table below lists the signal assignments for the I/O flat cable under different PIO patterns. Connect an external device (such as PLC) according to this table.

Pin number	Category	PIO function	Parameter No.25, "PIO Pattern Selection"							
			0	1	2	3	4	5	6	7
			Positioning mode	Teaching mode	256-point mode	512-point mode	Solenoid valve mode 1	Solenoid valve mode 2	Force control mode 1	Force control mode 2
	Input	Number of positioning points	64 points	64 points	256 points	512 points	7 points	3 points	32 points	5 points
		Home return signal	○	○	○	○	○	—	○	○
		Jog signal	—	○	—	—	—	—	—	—
		Teaching signal (current position writing)	—	○	—	—	—	—	—	—
	Output	Brake release	○	—	○	○	○	○	○	○
		Moving signal	○	○	—	—	—	—	—	—
		Zone signal	○	△ (Note 1)	△ (Note 1)	—	○	○	△ (Note 1)	△ (Note 1)
		Position zone signal	○	○	○	—	○	○	○	○
1A	24V	P24								
2A	24V	P24								
3A	—	—								
4A	—	—								
5A	Input	IN0	PC1	PC1	PC1	PC1	ST0	ST0	PC1	ST0
6A		IN1	PC2	PC2	PC2	PC2	ST1	ST1(JOG+)	PC2	ST1
7A		IN2	PC4	PC4	PC4	PC4	ST2	ST2 (non-functional)	PC4	ST2
8A		IN3	PC8	PC8	PC8	PC8	ST3	—	PC8	ST3
9A		IN4	PC16	PC16	PC16	PC16	ST4	—	PC16	ST4
10A		IN5	PC32	PC32	PC32	PC32	ST5	—	—	—
11A		IN6	—	MODE	PC64	PC64	ST6	—	—	—
12A		IN7	—	JISL	PC128	PC128	—	—	—	—
13A		IN8	—	JOG+	—	PC256	—	—	CLBR	CLBR
14A		IN9	BKRL	JOG-	BKRL	BKRL	BKRL	BKRL	BKRL	BKRL
15A		IN10	RMOD	RMOD	RMOD	RMOD	RMOD	RMOD	RMOD	RMOD
16A		IN11	HOME	HOME	HOME	HOME	HOME	—	HOME	HOME
17A		IN12	*STP	*STP	*STP	*STP	*STP	—	*STP	*STP
18A		IN13	CSTR	CSTR/PWRT	CSTR	CSTR	—	—	CSTR	—
19A		IN14	RES	RES	RES	RES	RES	RES	RES	RES
20A	IN15	SON	SON	SON	SON	SON	SON	SON	SON	
1B	Output	OUT0	PM1(ALM1)	PM1(ALM1)	PM1(ALM1)	PM1(ALM1)	PE0	LSO	PM1	PE0
2B		OUT1	PM2(ALM2)	PM2(ALM2)	PM2(ALM2)	PM2(ALM2)	PE1	LS1(TRQS)	PM2	PE1
3B		OUT2	PM4(ALM4)	PM4(ALM4)	PM4(ALM4)	PM4(ALM4)	PE2	LS2 (Note 2)	PM4	PE2
4B		OUT3	PM8(ALM8)	PM8(ALM8)	PM8(ALM8)	PM8(ALM8)	PE3	—	PM8	PE3
5B		OUT4	PM16	PM16	PM16	PM16	PE4	—	PM16	PE4
6B		OUT5	PM32	PM32	PM32	PM32	PE5	—	TRQS	TRQS
7B		OUT6	MOVE	MOVE	PM64	PM64	PE6	—	LOAD	LOAD
8B		OUT7	ZONE1	MODES	PM128	PM128	ZONE1	ZONE1	CEND	CEND
9B		OUT8	PZONE/ZONE2	PZONE/ZONE1	PZONE/ZONE1	PM256	PZONE/ZONE2	PZONE/ZONE2	PZONE/ZONE1	PZONE/ZONE1
10B		OUT9	RMDS	RMDS	RMDS	RMDS	RMDS	RMDS	RMDS	RMDS
11B		OUT10	HEND	HEND	HEND	HEND	HEND	HEND	HEND	HEND
12B		OUT11	PEND	PEND/WEND	PEND	PEND	PEND	—	PEND	PEND
13B		OUT12	SV	SV	SV	SV	SV	SV	SV	SV
14B		OUT13	*EMGS	*EMGS	*EMGS	*EMGS	*EMGS	*EMGS	*EMGS	*EMGS
15B		OUT14	*ALM	*ALM	*ALM	*ALM	*ALM	*ALM	*ALM	*ALM
16B	OUT15	LOAD/TRQS *ALML	*ALML	LOAD/TRQS *ALML	LOAD/TRQS *ALML	LOAD/TRQS *ALML	*ALML	*ALML	*ALML	
17B	—	—								
18B	—	—								
19B	0V	N								
20B	0V	N								

(Note) In the table above, the asterisk (*) symbol accompanying each code indicates a negative logic signal. PM1 through PM8 are alarm binary code output signals when an alarm is generated.

(Note 1) In all PIO patterns other than pattern 3, this signal can be switched with PZONE by setting Parameter No.149 accordingly.

(Note 2) The setting will not become enabled until the home return is completed.

Reference: Negative logic signals

Signals denoted by * are negative logic signals. Negative logic input signals are processed when turned OFF.

Negative logic output signals normally remain ON while the power is supplied, and turn OFF when the function is active.

Field Network Specification: Explanation of Operation Modes

If controlling via a field network, one of the following 8 modes can be selected to operate the actuator. Please note that the data areas required on the PLC side will vary depending on the mode.

Mode description

	Mode	Description
0	Remote I/O mode	Similar to the PIO specification, this mode operates by turning bits ON/OFF over a network. The number of positioning points and functions will vary depending on the operation patterns (PIO patterns) set by the controller's parameters.
1	Position/simple direct value mode	The target position value is directly input, while all other operational conditions (speed, acceleration, etc.) are used by specifying the position number of the desired operating condition entered in position data.
2	Half direct value mode	The actuator is operated by directly inputting values for speed, acceleration/deceleration and push current, as well as the target position.
3	Full direct value mode	The actuator is operated by directly inputting values for the target position, speed, acceleration/deceleration, push current limit value, etc. The current position, current speed, command current value and load cell data can also be read.
4	Remote I/O mode 2	This mode is the same as the remote I/O mode above, with the added functionality of reading current position and command current value.
5	Position/simple direct value mode 2	This mode provides a force control function instead of teaching and zone functions of the position/simple direct value mode above.
6	Half direct value mode 2	This mode can read load cell data instead of the command current, which is a function of the half direct value mode above.
7	Remote I/O mode 3	This mode is the same as the remote I/O mode above, with the added functionality of reading current position and load cell data.

Required data size for each network

	Mode	DeviceNet	CompoNet	CC-Link	CC-Link IE Field	—	PROFIBUS-DP	EtherCAT	EtherNet/IP	PROFINET IO
0	Remote I/O mode	2 bytes	2 bytes	1 station	4 words	—	2 bytes	2 bytes	2 bytes	2 bytes
1	Position/simple direct value mode	8 bytes	8 bytes	1 station	4 words	—	8 bytes	8 bytes	8 bytes	8 bytes
2	Half direct value mode	16 bytes	16 bytes	2 stations	8 words	—	16 bytes	16 bytes	16 bytes	16 bytes
3	Full direct value mode	32 bytes	32 bytes	4 stations	16 words	—	32 bytes	32 bytes	32 bytes	32 bytes
4	Remote I/O mode 2	12 bytes	12 bytes	1 station	4 words	—	12 bytes	12 bytes	12 bytes	12 bytes
5	Position/simple direct value mode 2	8 bytes	8 bytes	1 station	4 words	—	8 bytes	8 bytes	8 bytes	8 bytes
6	Half direct value mode 2	16 bytes	16 bytes	2 stations	8 words	—	16 bytes	16 bytes	16 bytes	16 bytes
7	Remote I/O mode 3	12 bytes	12 bytes	1 station	4 words	—	12 bytes	12 bytes	12 bytes	12 bytes

List of functions by operation mode

Mode	Remote I/O mode	Position/simple direct value mode	Half direct value mode	Full direct value mode	Remote I/O mode 2	Position/simple direct value mode 2	Half direct value mode 2	Remote I/O mode 3
Number of positioning points	512 points	768 points	Unlimited	Unlimited	512 points	768 points	Unlimited	512 points
Operates by direct assignment of position data	—	○	○	○	—	○	○	—
Direct assignment of speed/acceleration	—	—	○	○	—	—	○	—
Push-motion operation	○	○	○	○	○	○	○	○
Current position reading	—	○	○	○	○	○	○	○
Current speed reading	—	—	○	○	—	—	○	—
Operation by specifying position No.	○	○	—	—	○	○	—	○
Completed position number reading	○	○	—	—	○	○	—	○
Force control	△ (Note)	—	—	○	△ (Note)	○	○	△ (Note)
Current load data reading	—	—	—	○	—	○	○	○

* ○ indicates that the operation is supported, and — indicates that it is not supported.
 (Note) Usable when PIO pattern is set to 6 or 7.

Specification List

Item	Specification	
	PCON-CBP/CGBP	
Number of controlled axes	1 axis	
Power supply voltage	24VDC \pm 10%	
Load current (including control-side current consumption) (Note 1)	High-output setting disabled: 2.2A max. High-output setting enabled: 3.5A rated / 4.2A max.	
Electromagnetic brake power (for actuator with brake)	24VDC \pm 10%, 0.15A (max.)	
Inrush current (Note 2)	8.3A	
Momentary power failure resistance	500 μ s max.	
Supported encoder	High-resolution battery-less absolute encoder: 8192 pulses/rev	
Actuator cable length	20m max.	
External interface	PIO specification	Dedicated 24VDC signal input/output (NPN/PNP selection) Input max. of 16 points, output max. of 16 points, cable length max. of 10m
	Field network specification	DeviceNet, CC-Link, CC-Link IE Field, PROFIBUS-DP, CompoNet, EtherCAT, EtherNet/IP, PROFINET IO
Data setting, input method	PC software, touch panel teaching pendant	
Data retention memory	Position data and parameters are saved in non-volatile memory (no limit to rewrite).	
Operation mode	Positioner mode	
Number of positioner-mode positions	Up to 512 points for positioner type or up to 768 points for network type (Note) The total number of positioning points varies depending on which PIO pattern is selected.	
Insulation resistance	10M Ω or more at 500VDC	
Electric shock protection mechanism	Class I, basic insulation	
Mass (Note 3)	Screw mounting specification: 250g or less, DIN rail mounting specification: 285g or less	
Cooling method	Natural air cooling	
Environment	Ambient operating temperature	0 ~ 40°C
	Ambient operating humidity	85% RH or less (no condensation)
	Operating environment	Free from corrosive gases
	Degree of protection	IP20

(Note 1) 0.3A higher for the field network specification.

(Note 2) Inrush current flows for approx. 5 msec after power is turned ON (at 40°C). Please note that the inrush current value varies depending on the impedance of the power line.

(Note 3) 30g heavier for the field network specification.

<PCON-CBP/CGBP>

Screw mounting specification

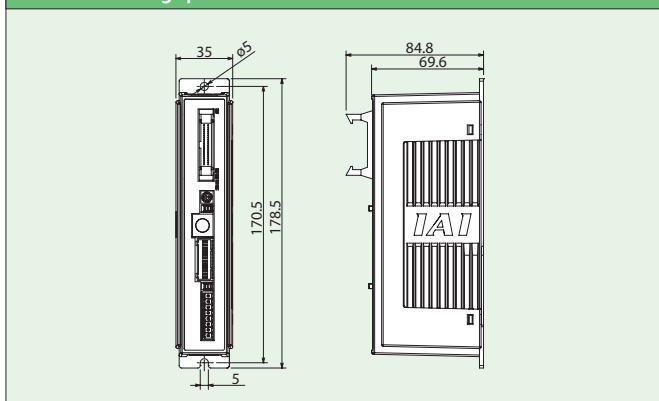

DIN rail mounting specification

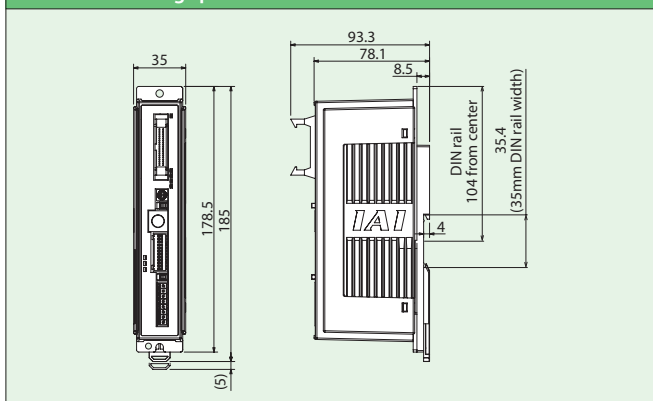

Part Names

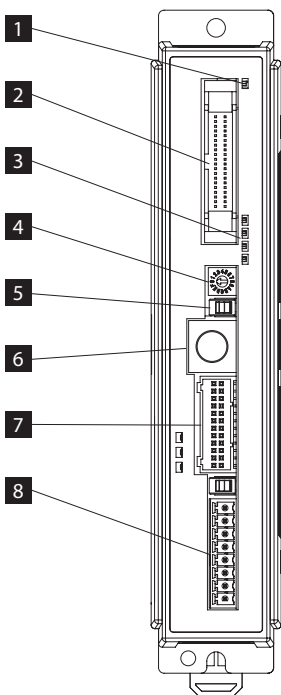

1 Controller display status LED

Indicates the status of the controller.

○: ON, -: OFF, *: Blinking

LED		Operating status
SV (green)	ALM (red)	
-	-	Control power OFF
-	-	Servo OFF
-	○	Alarm (operation cancel level or above)
-	○	Motor drive power supply OFF
-	○	Emergency stop
○	-	Servo ON
*	-	AUTO servo OFF
○ (orange)		Initialized when power is turned ON

2 PIO connector /field network connector

Cable connector for performing parallel communication with peripheral devices such as PLC.

3 Current/alarm monitor LED

Displays the command current ratio normally. Displays the alarm code when an alarm occurs.

LED	Operating status			
STS3 (green)	Status display • Servo ON: Displays the current command current ratio (proportion of rated value).			
STS2 (green)	STATUS			
	3	2	1	0
STS1 (green)	ALM8	ALM4	ALM2	ALM1
	-	-	-	-
STS0 (green)	○	○	○	○
	○	○	○	○

• In case of alarm: Displays a simple alarm code.

4 Axis number setting switch

Used to set an address to identify each controller, when controllers are linked.

5 Operation mode setting switch

Switch for the interlock.

Name	Description
MANU	Commands from PIO are not received.
AUTO	Commands from PIO can be received.

* The emergency stop switch on the touch panel teaching pendant is enabled when the connection is made, regardless of the status (AUTO or MANU). Be sure to turn the power OFF when disconnecting the touch panel teaching pendant and SIO communication cable.

6 SIO connector

Connector for touch panel teaching pendant or PC communication.

7 Motor/encoder connector

Connector for the actuator motor and encoder cable.

8 Power supply connector

Connector for power supply and emergency stop status signal input.

Maintenance Parts

When placing an order for a replacement cable after purchasing a product, please use the model name shown below.

Table of compatible cables

Model name	Motor/encoder cable	Motor/encoder robot cable
RCP6-RAA□□R-LCT	CB-CAN-MPA□□□ *1	CB-CAN-MPA□□□-RB *2

* 1 Revision no. 5 or later * 2 Revision no. 6 or later

Model name	PIO flat cable
PCON-CBP/CGBP	CB-PAC-PIO□□□

Model CB-CAN-MPA□□□/CB-CAN-MPA□□□-RB

* Please indicate the cable length (L) in □□□, maximum 10m
Example) 080 = 8m

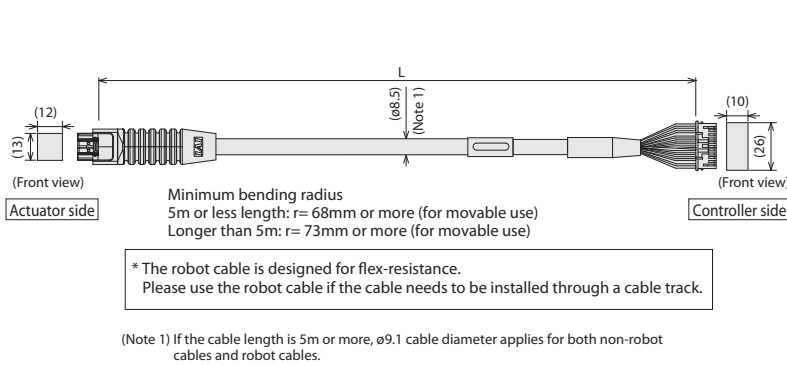

Actuator side DF62DL-24S-2.2C (Hirose)				Controller side PADP-24V-1-S (J.S.T.Mfg. Co., Ltd.)			
Standard cable	Robot cable	Signal name	Pin No.	Pin No.	Signal name	Standard cable	Robot cable
Blue (AWG22/19)	Blue (AWG22/19)	eA	3	1	eA	Blue (AWG22/19)	Blue (AWG22/19)
Orange (AWG22/19)	Orange (AWG22/19)	VMM	5	2	VMM	Orange (AWG22/19)	Orange (AWG22/19)
Brown (AWG22/19)	Brown (AWG22/19)	eB	10	3	eB	Brown (AWG22/19)	Brown (AWG22/19)
Gray (AWG22/19)	Gray (AWG22/19)	VMM	9	4	VMM	Gray (AWG22/19)	Gray (AWG22/19)
Green (AWG22/19)	Green (AWG22/19)	e A	4	5	e A	Green (AWG22/19)	Green (AWG22/19)
Red (AWG22/19)	Red (AWG22/19)	e B	15	6	e B	Red (AWG22/19)	Red (AWG22/19)
Light blue (AWG26)	Light blue (AWG26)	S8(m)BS	12	11	S8(m)BS	Light blue (AWG26)	Light blue (AWG26)
Orange (AWG26)	Orange (AWG26)	S8(m)BS	17	12	S8(m)BS	Orange (AWG26)	Orange (AWG26)
Green (AWG26)	Green (AWG26)	A+	1	13	A+	Green (AWG26)	Green (AWG26)
Brown (AWG26)	Brown (AWG26)	A-	6	14	A-	Brown (AWG26)	Brown (AWG26)
Gray (AWG26)	Gray (AWG26)	B+	11	15	B+	Gray (AWG26)	Gray (AWG26)
Red (AWG26)	Red (AWG26)	B-	16	16	B-	Red (AWG26)	Red (AWG26)
Black (AWG26)	Black (AWG26)	VPS	18	18	VPS	Black (AWG26)	Black (AWG26)
Yellow (AWG26)	Yellow (AWG26)	LDC_VCC	8	7	LDC_VCC	Yellow (AWG26)	Yellow (AWG26)
Light blue (AWG26)	Light blue (AWG26)	BK+	20	9	BK+	Light blue (AWG26)	Light blue (AWG26)
Orange (AWG26)	Orange (AWG26)	BK-	2	10	BK-	Orange (AWG26)	Orange (AWG26)
Gray (AWG26)	Gray (AWG26)	VCC	21	17	VCC	Gray (AWG26)	Gray (AWG26)
Red (AWG26)	Red (AWG26)	00LDC_00	7	19	00LDC_00	Red (AWG26)	Red (AWG26)
Brown (AWG26)	Brown (AWG26)	LDC_SD+	14	8	LDC_SD+	Brown (AWG26)	Brown (AWG26)
Green (AWG26)	Green (AWG26)	LDC_SD-	13	20	LDC_SD-	Green (AWG26)	Green (AWG26)
—	—	—	—	22	—	—	—
—	—	—	—	19	—	—	—
Pink (AWG26)	Pink (AWG26)	CF_VCC	22	21	CF_VCC	Pink (AWG26)	Pink (AWG26)
—	—	—	—	23	—	—	—
Black (AWG26)	Green (AWG26)	FG	24	24	FG	Black (AWG26)	Green (AWG26)

Model CB-PAC-PIO□□□

* Please indicate the cable length (L) in □□□, maximum 10m
Example) 080 = 8m

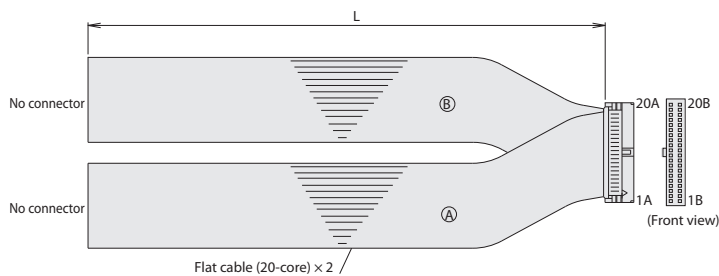

HIF6-40D-1.27R (Hirose)				HIF6-40D-1.27R (Hirose)			
No.	Signal name	Cable color	Wiring	No.	Signal name	Cable color	Wiring
1A	24V	Brown-1	1B	OUT0	Brown-3	1B	OUT0
2A	24V	Red-1	2B	OUT1	Red-3	2B	OUT1
3A	—	Orange-1	3B	OUT2	Orange-3	3B	OUT2
4A	—	Yellow-1	4B	OUT3	Yellow-3	4B	OUT3
5A	IN0	Green-1	5B	OUT4	Green-3	5B	OUT4
6A	IN1	Blue-1	6B	OUT5	Blue-3	6B	OUT5
7A	IN2	Purple-1	7B	OUT6	Purple-3	7B	OUT6
8A	IN3	Gray-1	8B	OUT7	Gray-3	8B	OUT7
9A	IN4	White-1	9B	OUT8	White-3	9B	OUT8
10A	IN5	Black-1	10B	OUT9	Black-3	10B	OUT9
11A	IN6	Brown-2	11B	OUT10	Brown-4	11B	OUT10
12A	IN7	Red-2	12B	OUT11	Red-4	12B	OUT11
13A	IN8	Orange-2	13B	OUT12	Orange-4	13B	OUT12
14A	IN9	Yellow-2	14B	OUT13	Yellow-4	14B	OUT13
15A	IN10	Green-2	15B	OUT14	Green-4	15B	OUT14
16A	IN11	Blue-2	16B	OUT15	Blue-4	16B	OUT15
17A	IN12	Purple-2	17B	—	Purple-4	17B	—
18A	IN13	Gray-2	18B	—	Gray-4	18B	—
19A	IN14	White-2	19B	0V	White-4	19B	0V
20A	IN15	Black-2	20B	0V	Black-4	20B	0V