

RoboCylinder Ultra-High Thrust Type

RCS2-RA13R

Maximum Press Force

2t

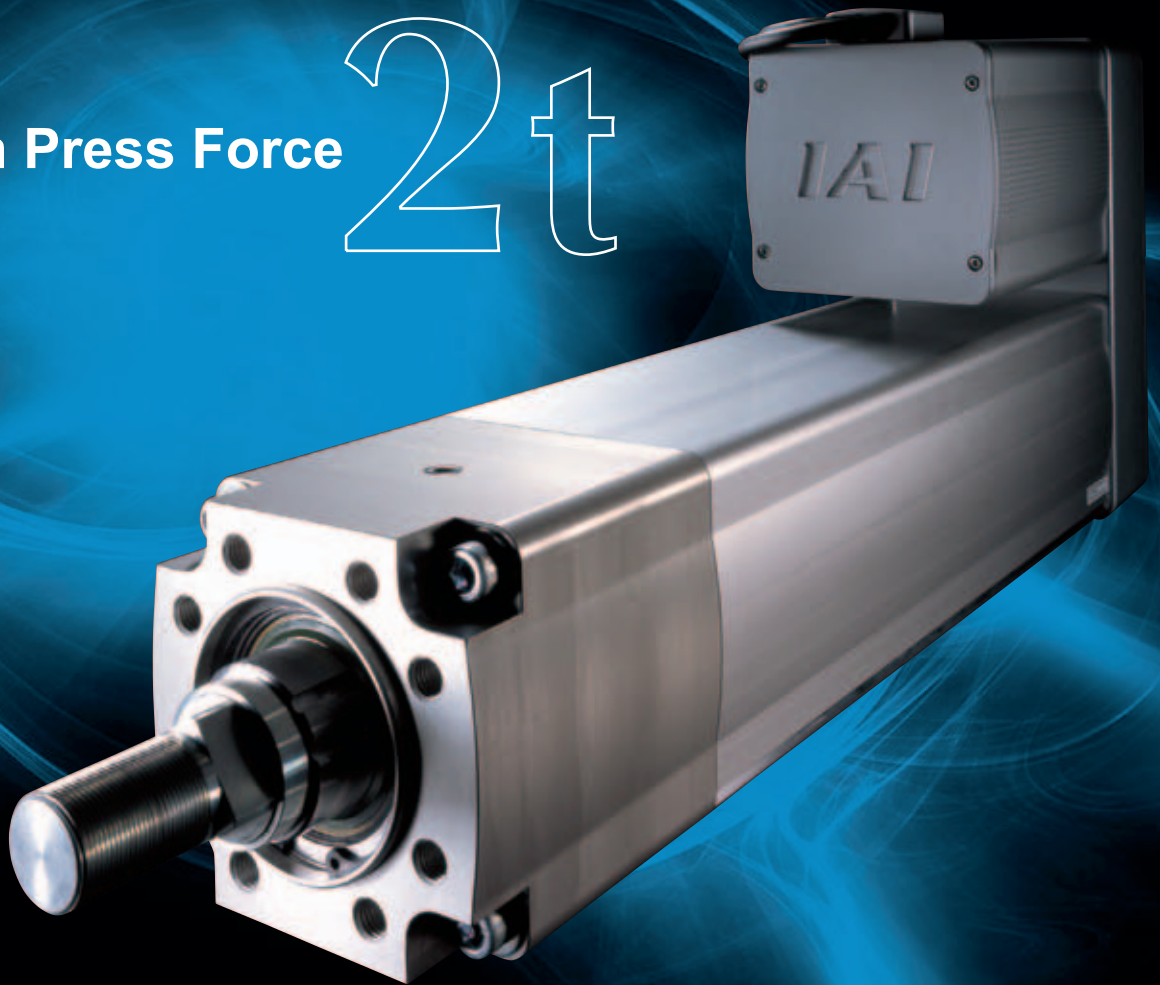

The Birth of the Ultra-High Thrust Actuator Can Also Be Used as a Simple Press

RCS2-RA13R

This electrical actuator provides high-precision positioning control and a maximum of 2 tons of pressing force thanks to its high-output servo motor. Makes it easy to set the pressing force adjustment and position control that are so difficult with hydraulic presses.

1 Provides a maximum pressing force of 2 t (19600 N) and position repetition precision of ± 0.01 mm

Provides a maximum of 2 t (19600 N) pressing force, greatly improving the thrust compared to previous electric actuators. This makes it possible to use this even for work such as press fitting and staking that require powerful pressing force. Also, speed adjustment during movement, height management during press fitting, and other such adjustments that were difficult with mechanical presses and hydraulic presses can be made easily by just changing the variables.

Usage examples

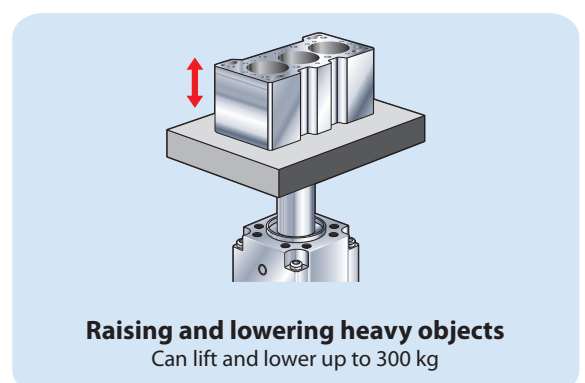
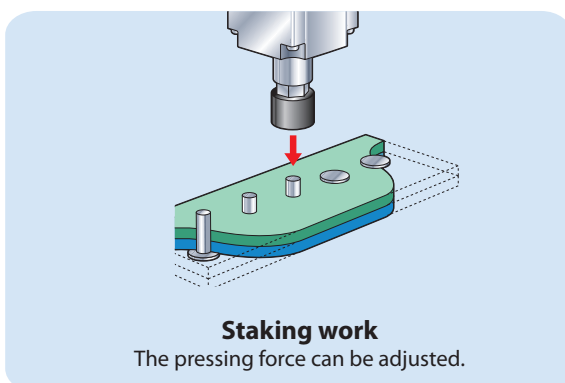
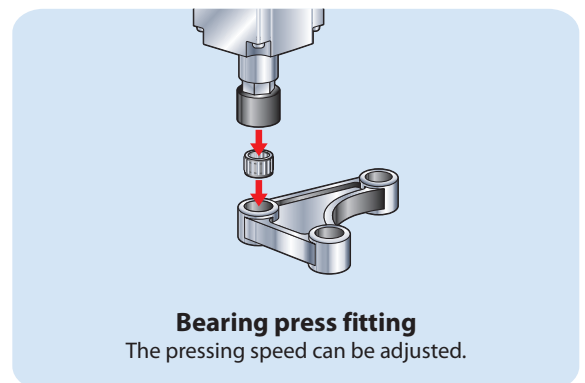
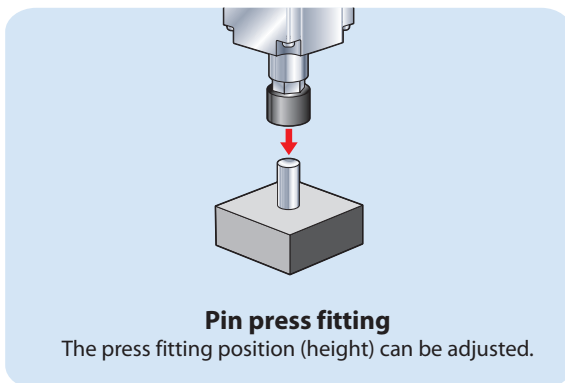



2 Thanks to the ball spline, the rod can handle both radial and rotating loads.

Because a ball spline is used as the rotation stopper for the rod, if the load is light, the rod can handle both radial and rotational loads without the necessity to add a guide mechanism.

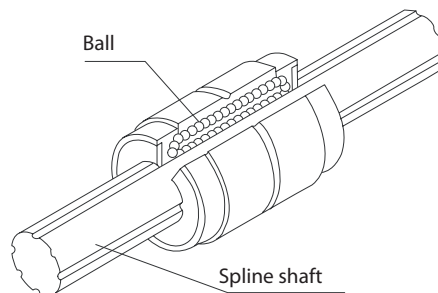
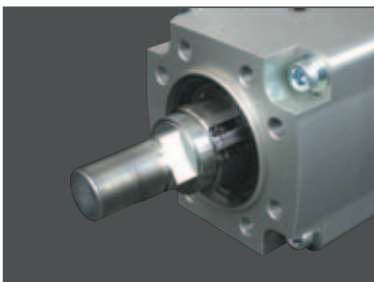

3 Can transport a maximum of 500 kg horizontally or 300 kg vertically.

The rated high thrust of 10211 N makes it possible to transport work of 500 kg* horizontally or 300 kg vertically.

When the option holding brake is installed, it can be set so that when the unit is used vertically and the power is switched off, the rod does not descend and interfere with peripheral equipment.

* This horizontal transport is for when an external guide is attached and the actuator is used for thrust.

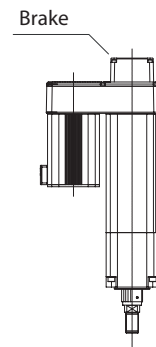

4 For the operation method, both a positioner and pulse string control are supported.

The controller supports both positioner operations, in which the unit is moved by just specifying the desired position number, and pulse string control, which allows the customer to freely change the moving position, speed, and acceleration and deceleration. Direct connection to DeviceNet, CC-Link, and ProfiBus is also possible.

* The field network is an option setting.

Pulse string control through a field network is not possible.



System configuration

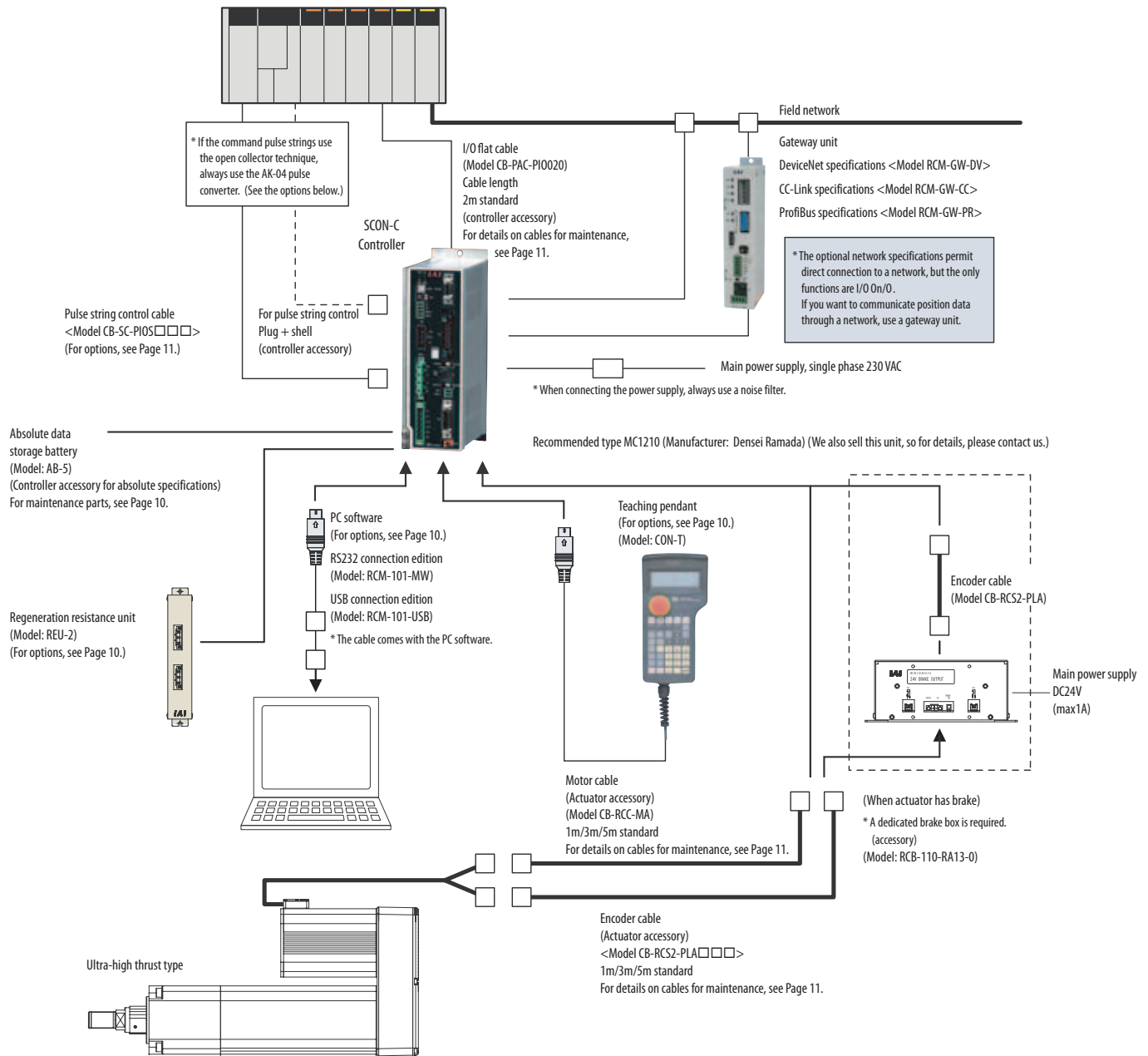

Pulse converter AK-04 (option)

Contents: Pulse converter (AK-04) + Input/output E-Con connector

Please use this option when the upper-level controller output pulses use the open collector specifications.

This converter is for converting command pulses to the differential technique when the upper-level controller output pulses use the open collector specifications. Converting to the differential technique improves the capacity to withstand noise. Two phases of differential output equivalent to that for line driver 26C31 are output.

The input/output connectors are E-CON connectors, which are easy to wire in the field.

Basic specifications

- Input power supply: 24 VDC±10% (50mA max.)
- Input pulses: Open collector (12 mA max. collector current)
- Input frequency: 200 kHz max.
- Output pulses: 26C31 equivalent differential output (10 mA max.)
- External dimensions: See figure on the right
(Cable connector not included)
- Weight: 10 g max. (Cable connector not included)
- Accessories: Input/output E-CON connector
37104-3122-000FL made by 3M
(Compatible wire: AWG No.24-26, 0.14 - less than 0.3 mm²
Finished exterior form ø1.0 ... 1.2 mm)

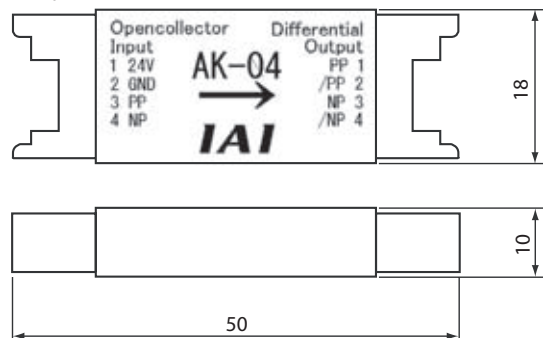

Model

When selecting multiple options, enter them in alphabetical order.

RCS2 — RA13R — [] — 750 — [] — [] — T2 — [] — []

Series Type Encoder type Motor type Lead Stroke Adaptive controller Cable length Options

I	Incremental	2.5	1t type	50	50mm	T2	SCON	N	No cable	B	Brakes
A	Absolute	1.25	2t type	~	~			P	1m	C2	Motor turning back direction
				200	200mm			S	3m	C3	back direction & Cable
				Set each 50 mm				M	5m	R1	take-out direction
								Xaa	Length specified	L1	take-out direction
								Raa	Robot cable	L3	take-out direction
										FT	Foot fitting
										FL	Flange

Motor turning back direction/cable take-out position (option)

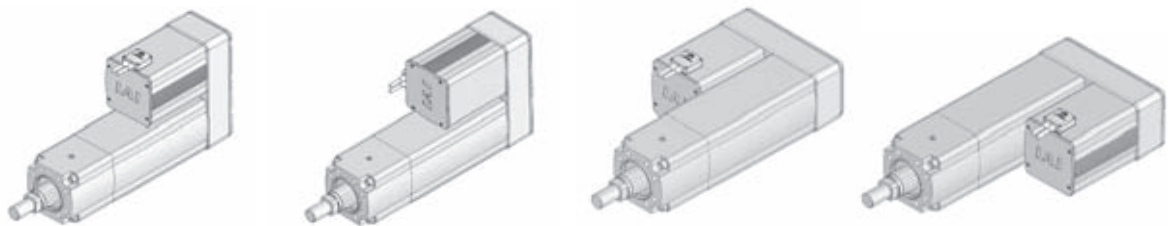

Option code	MT1	MT2	MR1	ML1
Motor turning back direction	Up (standard)	Up	Right	Left
Cable take-out position	Up (standard)	Right	Up	Up

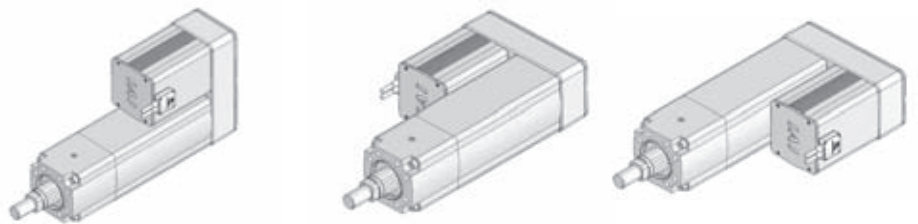

Option code	MT3	MR2	ML3
Motor turning back direction	Up	Right	Left
Cable take-out position	Left	Right	Left

Foot fitting/flange (option)

■ Foot fitting Stand-alone model RCS2-FT-RA13

st	A	B	C	D
50	40	2	42.5	6
100	65	2	67.5	6
150	40	3	42.5	8
200	65	3	67.5	8

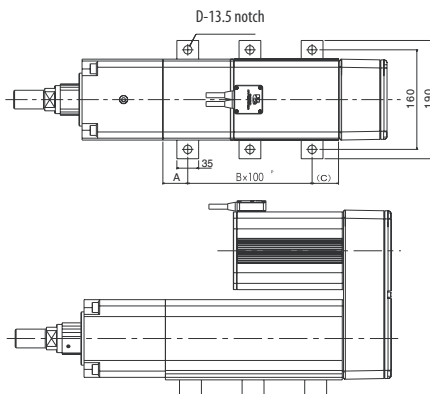
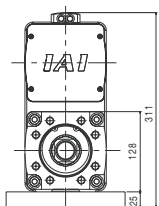

■ Flange Stand-alone model RCS2-FL-RA13

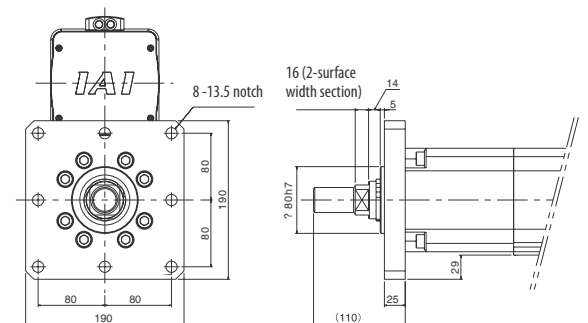

RCS2-RA13R

Robo Cylinder Ultra-High Thrust Rod Type Main unit width 130mm 230V servo motor Motor reversing specifications

Model item	RCS2 - RA13R	-	<input type="checkbox"/>	-	750	-	<input type="checkbox"/>	-	<input type="checkbox"/>	-	T2	-	<input type="checkbox"/>	-	<input type="checkbox"/>
Series	Type	Encoder type	Motor type	Lead	Stroke	Adaptive controller	Cable length	Options							
		I: Incremental specifications A: Absolute specifications	750: Servo motor 750W	2.5:2.5mm 1.25:1.25mm	50:50mm 200:200mm (Set in units of 50 mm)	T2:SCON	N: None P: 1m S: 3m M: 5m X: Length specified R: Robot cable	See the option price table below.							

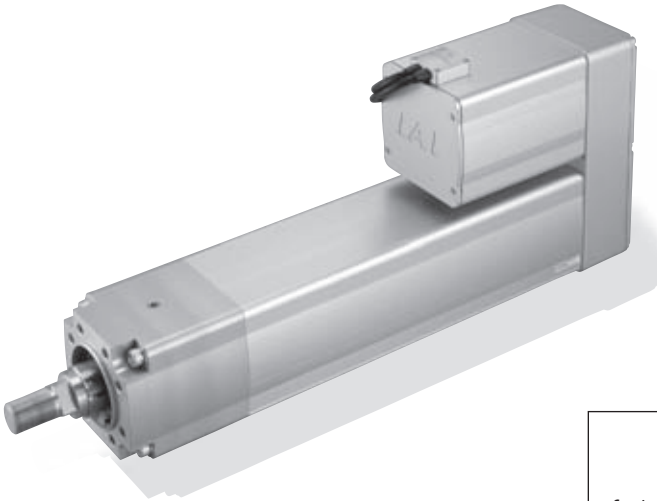

Correlation diagram of pressing force and current restriction value

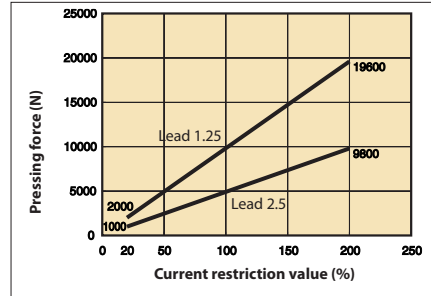

- Notes:
- The numbers for the relationship between the pressing force and current restriction value are just rough representations, so they may differ some from the actual numbers.
 - There can be variation in the pressing force when the current restriction value is low, so use at 20% or higher.
 - The movement speed is fixed to 10 mm/s for pressing operation.
 - Be aware that since the graph is for pressing at 10 mm/s, if the speed is different, the pressing force drops.
 - Depending on the operating conditions, the rise in the motor temperature may reduce the pressing force.

Cautions	(1) When pressing operations are carried out, the continuous usage time is determined by the pressing force set. Even in normal operation, it is necessary that the continuous operation thrust be less than the rated thrust to take load and duty ratio into account. For details, see the selection documentation (Page 12).
	(2) The horizontal transport weight is the figure for when an external guide is used also and the rod is free from external force other than in the direction of progress.
	(3) When the optional brake is installed, a brake box is required besides the main unit and controller. (For accessories, see Page 7.)

Actuator specs

Lead and transportable weight

Model	Motor output (W)	Lead (mm)	Maximum acceleration (G)	Maximum transportable weight		Rated thrust (N)	Maximum thrust (N)	Stroke (mm)
				Horizontal (kg)	Vertical (kg)			
RCS2-RA13R-①-750-2.5-②-T2-③-④	750	2.5	0.02	400	200	5106	9800	50~200 (in units of 50 mm)
RCS2-RA13R-①-750-1.25-②-T2-③-④		1.25	0.01	500	300	10211	19600	

Codes ① Encoder type ② Stroke ③ Cable length ④ Options

Stroke and maximum speed

Lead (mm)	Stroke (mm)			
	50	100	150	200
2.5	85	120	125	
1.25	62			

(mm/s)

Table by ① Encoder type / ② Stroke

② Stroke (mm)	Type code			
	RA13R			
	① Encoder type			
	Incremental		Absolute	
50				
100				
150				
200	1t type (lead 2.5)	2t type (lead 1.25)	1t type (lead 2.5)	2t type (lead 1.25)

③ Table by cable length

Type	Cable code
Standard type	P(1m)
	S(3m)
	M(5m)
Special length	X06(6m) ~ X10(10m)
	X11(11m) ~ X15(15m)
	X16(16m) ~ X20(20m)
Robot cable	R01(1m) ~ R03(3m)
	R04(4m) ~ R05(5m)
	R06(6m) ~ R10(10m)
	R11(11m) ~ R15(15m)
	R16(16m) ~ R20(20m)

? Option table

Name	Option code	Reference page
Brakes (with brake box)	B	P6
Brakes (without brake box)	BN	P6
Motor upper side turning back	MT1/MT2/MT3	P4
Motor right side turning back	MR1/MR2	P4
Motor left side turning back	ML1/ML3	P4
Flang	FL	P4
Foot fitting	FT	P4

Actuator specifications

Item	Contents
Drive type	Ball screw ø32 mm C10 form rolled
Position repetition precision	±0.01mm
Backlash	0.2mm max.
Rod diameter	ø50 mm (ball spline)
Permitted rod moment	120N · m
Usage ambient temperature and humidity	0~40°C, 85% RH max. (no condensation allowed)

Dimension diagram

CAD drawings can be downloaded. www.robocylinder.de

2D CAD

[No-brake specifications]

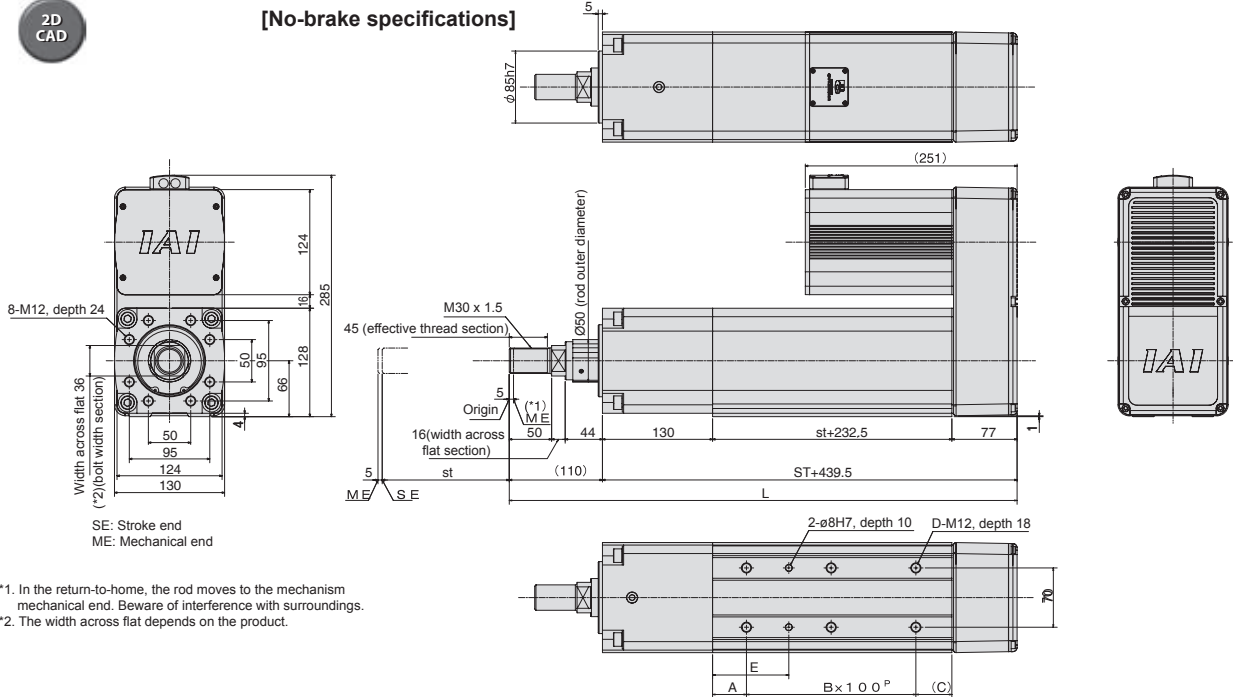

[With brake specifications]

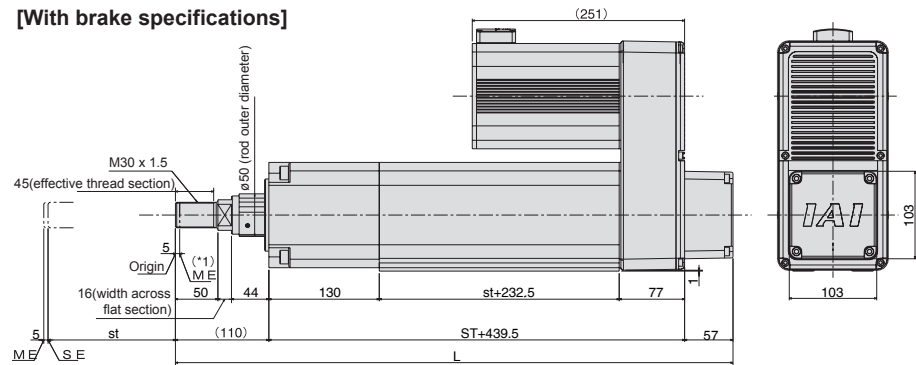

Caution
The brake specification model (option model-B) always comes with a brake box. (See Page 7.) To arrange for just the actuator main unit for a model with the brake specifications, please select option model -BN.

■ Dimensions and weight by stroke

RCS2-RA13R (no brake)

Stroke	50	100	150	200
L	599.5	649.5	699.5	749.5
A	40	65	40	65
B	2	2	3	3
C	42.5	67.5	42.5	67.5
D	6	6	8	8
E	90	115	90	115
Weight (kg)	33	34	35	36

RCS2-RA13R (with brake)

Stroke	50	100	150	200
L	656.5	706.5	756.5	806.5
A	40	65	40	65
B	2	2	3	3
C	42.5	67.5	42.5	67.5
D	6	6	8	8
E	90	115	90	115
Weight (kg)	35	36	37	38

Controller

Adaptive controller

The RCS2-RA13R can operate with the controllers below. Select the type that matches your application.

Name	Appearance	Model	Features	Maximum number of positioning points	Input power supply	Power supply capacity	Standard price	Reference page
Positioner mode		SCON-C-750①-NP-2-2	Can position up to 512 points.	512	Single phase 230 VAC	1569 VA max.	Incremental specifications	P7
Solenoid mode			Can operate with the same control as for a solenoid.	3/7				
Pulse string input control cable			Pulse string input dedicated type	(-)				

* ① is the encoder type (I: Incremental/A: Absolute).

Controller

SCON

Ultra-high position controller

- Position controller that can position up to 512 points
- Support for pulse string input makes possible free operation under customer control
- Can be directly connected to DeviceNet, CC-Link, and ProfiBus



Type List

There are two types of SCON controllers, the standard specifications that operate with PIO or pulse string input and the optional network connection specifications that operate connected to a field network. Both types have incremental specifications and absolute specifications, but when operating with pulse string input, operation is only incremental.

Type name	C								
Specifications	Standard specifications			Network connection specifications (Option)					
Details	Positioning mode / Teaching mode / Solenoid mode		Pulse string mode	DeviceNet connection specifications		CC-Link connection specifications		Profibus connection specifications	
Position point count	512 max.		(Unrestricted)	512 max.					
I/O type code	NP / PN			DV		CC		PR	
Supported encoder type	Incremental	Absolute	Incremental	Incremental	Absolute	Incremental	Absolute	Incremental	Absolute

Model

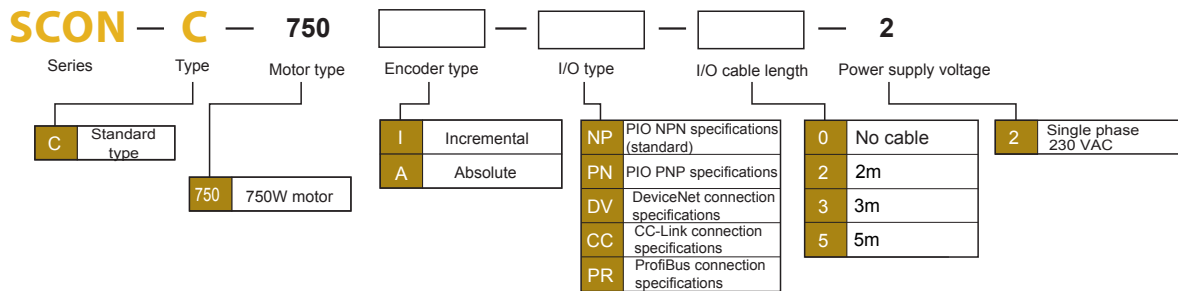

Specifications

	Controller series type	SCON
Basic specifications	Power supply capacity	1569 VA max.
	Input power supply	Single phase 200-230 ±10% VAC
	Within operating power supply voltage	±10%
Control specifications	Maximum number of axes controlled	1 axis
	Position detection technique	Incremental/absolute encoder
	Safety circuit configuration	Duplex not possible
	Drive power cut-off	Internal relay cut-off
	Enable input	B contact input (internal power feed type)
	Speed setting	1 mm/s - upper limit, depending on actuator
Position	Acceleration setting	0.01 G - upper limit, depending on actuator
	Operation technique	Positioner operation/pulse string control
	Position count	512 max.
	Data storage device	EEPROM
Input/output communications	Data input method	Teaching box or PC software
	Standard I/O	16 inputs/16 outputs (NPN/PNP can be selected)
	Expanded I/O	Not possible
	Serial communication functions	Teaching port (RS485) DeviceNet, CC-Link, Profibus
General specifications	Serial communication functions	DeviceNet, CC-Link, Profibus
	Usage ambient temperature and humidity	0-40°C, 10-95% (no condensation allowed)
	Usage ambient temperature	There must be no corrosive gas and low levels of dust
	External dimensions	72 (W) x 200.5 (H) x 121 (D)
	Weight	1.1 kg
Accessories	I/O flat cable (40 lines)	

Dimension Diagram

Controller main unit

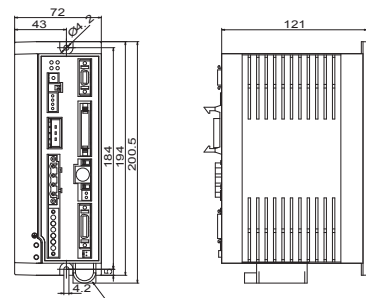

Brake box (accessory) (Accessory with brake specifications) Stand-alone model RCB-110-RA13-0

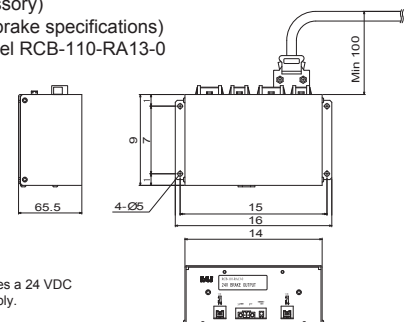

Caution

The brake box requires a 24 VDC (1A max.) power supply.

I/O wiring diagram

Positioning mode / Teaching mode / Solenoid mode

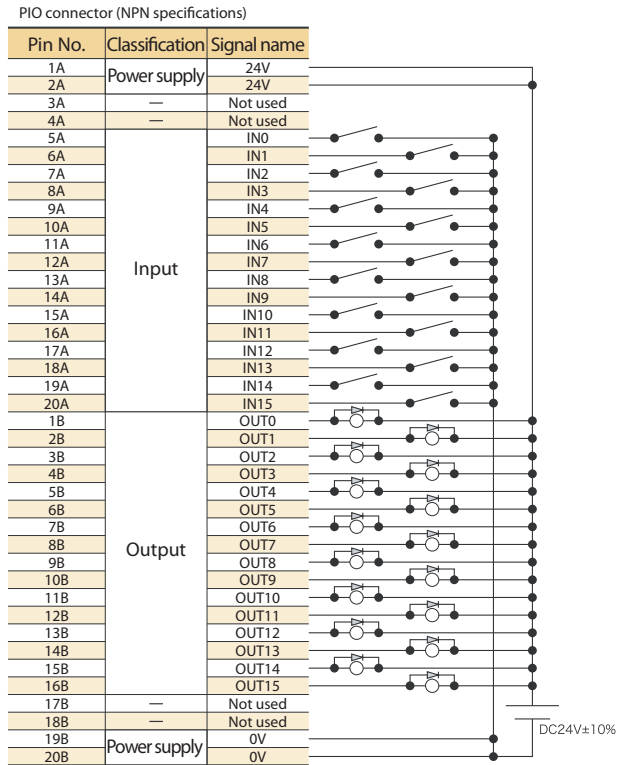

* Connect 24V to both pins 1A and 2A and connect 0V to both pins 19B and 20B.

Pulse string mode (differential output)

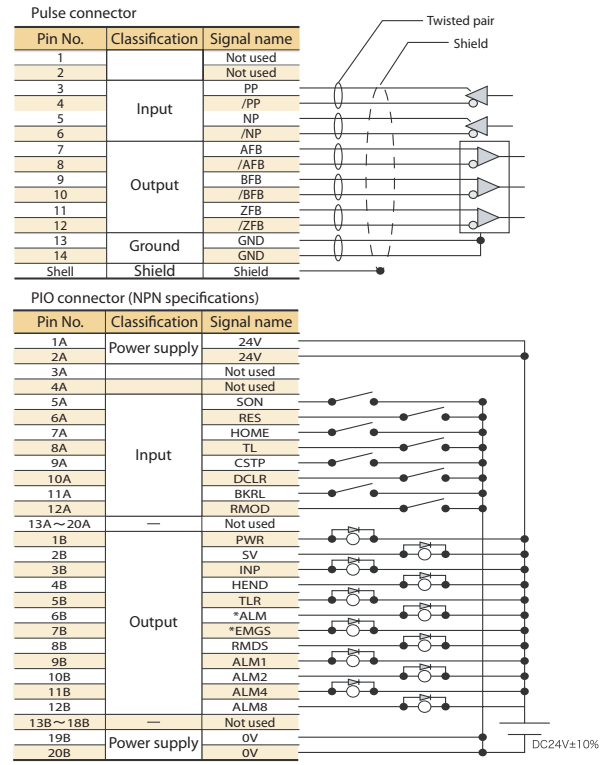

* Always connect the shield for the twisted pair cable connected to the pulse connector to the shell. Make the cable no longer than 10 meters.

* Connect 24V to both pins 1A and 2A and connect 0V to both pins 19B and 20B.

I/O signal table

* There are seven I/O signal assignment patterns to select from.

Pin No.	Classification	Number of positioning points Zone signal P zone signal	Parameter (PIO pattern) selection							Pulse string mode
										0
			0 Positioning mode	1 Teaching mode	2 256-point mode	3 512-point mode	4 Solenoid mode 1	5 Solenoid mode 2	0 Pulse string mode	
1A	24V									P24
2A	24V									P24
3A	—									NC
4A	—									NC
5A	Input	IN0	PC1	PC1	PC1	PC1	ST0	ST0	SON	
6A		IN1	PC2	PC2	PC2	PC2	ST1	ST1 (JOG+)	RES	
7A		IN2	PC4	PC4	PC4	PC4	ST2	ST2 (-)	HOME	
8A		IN3	PC8	PC8	PC8	PC8	ST3	—	TL	
9A		IN4	PC16	PC16	PC16	PC16	ST4	—	CSTP	
10A		IN5	PC32	PC32	PC32	PC32	ST5	—	DCLR	
11A		IN6	—	MODE	PC64	PC64	ST6	—	BKRL	
12A		IN7	—	JISL	PC128	PC128	—	—	RMOD	
13A		IN8	—	JOG+	—	PC256	—	—	—	
14A		IN9	BKRL	JOG-	BKRL	BKRL	BKRL	BKRL	—	
15A		IN10	RMOD	RMOD	RMOD	RMOD	RMOD	RMOD	—	
16A		IN11	HOME	HOME	HOME	HOME	HOME	—	—	
17A		IN12	*STP	*STP	*STP	*STP	*STP	—	—	
18A		IN13	CSTR	CSTR/PWRT	CSTR	CSTR	—	—	—	
19A	IN14	RES	RES	RES	RES	RES	RES	—		
20A	IN15	SON	SON	SON	SON	SON	SON	—		
1B	Output	OUT0	PM1	PM1	PM1	PM1	PE0	LSO	PWR	
2B		OUT1	PM2	PM2	PM2	PM2	PE1	LS1 (TRQS)	SV	
3B		OUT2	PM4	PM4	PM4	PM4	PE2	LS2	INP	
4B		OUT3	PM8	PM8	PM8	PM8	PE3	—	HEND	
5B		OUT4	PM16	PM16	PM16	PM16	PE4	—	TLR	
6B		OUT5	PM32	PM32	PM32	PM32	PE5	—	*ALM	
7B		OUT6	MOVE	MOVE	PM64	PM64	PE6	—	*EMGS	
8B		OUT7	ZONE1	MODES	PM128	PM128	ZONE1	ZONE1	RMDS	
9B		OUT8	PZONE	PZONE	PZONE	PM256	PZONE	PZONE	ALM1	
10B		OUT9	RMDS	RMDS	RMDS	RMDS	RMDS	RMDS	ALM2	
11B		OUT10	HEND	HEND	HEND	HEND	HEND	HEND	ALM4	
12B		OUT11	PEND	PEND/WEND	PEND	PEND	PEND	—	ALM8	
13B		OUT12	SV	SV	SV	SV	SV	SV	—	
14B		OUT13	*EMGS	*EMGS	*EMGS	*EMGS	*EMGS	*EMGS	—	
15B		OUT14	*ALM	*ALM	*ALM	*ALM	*ALM	*ALM	—	
16B	OUT15	*BALM	*BALM	*BALM	*BALM	*BALM	*BALM	—		
17B	—							—		
18B	—							—		
19B	0V					N		N		
20B	0V					N		N		

* The contents in the () in the above signal names are the functions before the return to the origin.

Pulse string type input/output specifications (differential line driver specifications)

Input section

Maximum input: Line driver interface 500 kpps
 Pulse count open connector interface 200 kpps (AK-04 required). Insulation type: photocoupler insulation

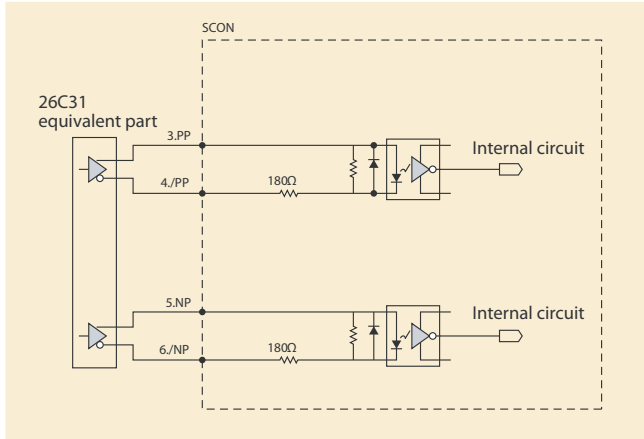

Output section

Output type: Line driver output
 Insulated/non-insulated: Non-insulated

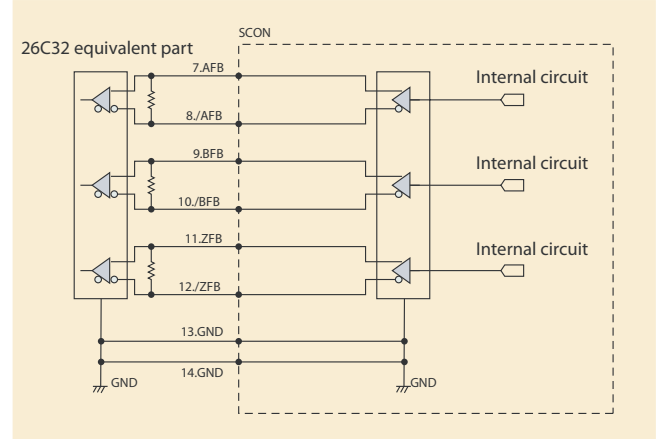

Pulse string type input/output specifications (open collector specifications)

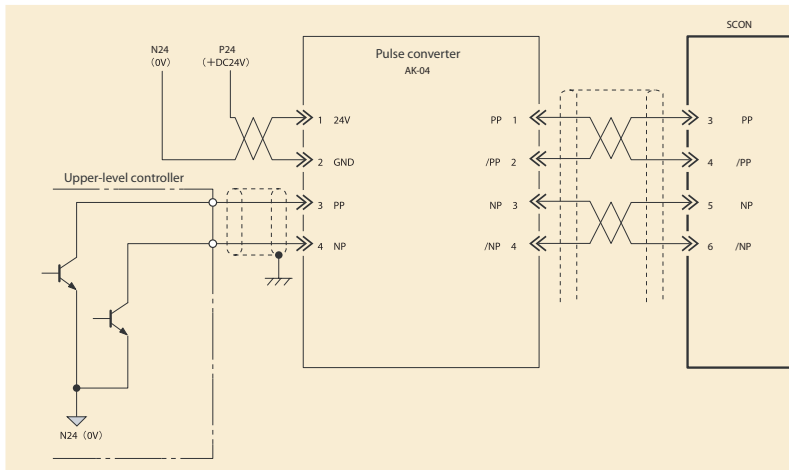

* For the 24VDC power supply connected to AK-04, use the same one connected to the PIO interface.

* Make the cable between the pulse output unit (PLC) and the AK-04 as short as possible. Use a cable no longer than 2 meters between the AK-04 and the pulse connector.

Command-pulse input mode

	Command pulse-train pattern	Input terminal	Forward	Reverse	
Negative logic	Forward pulse train	PP·/PP			
	Reverse pulse train	NP·/NP			
	A forward pulse train indicates motor revolutions in the forward direction, while a reverse pulse train indicates motor revolutions in the negative direction.				
	Pulse train	PP·/PP			
	Sign	NP·/NP	Low	High	
Command pulses indicate motor revolutions, while a command sin indicates a rotating direction.					
Positive logic	Phase-A/B pulse train	PP·/PP			
		NP·/NP			
	Phase-A/B x 4 pulses with a 90° phase difference indicate motor revolutions and a rotating direction.				
	Forward pulse train	PP·/PP			
	Reverse pulse train	NP·/NP			
Positive logic	Pulse train	PP·/PP	High	Low	
	Sign	NP·/NP	High	Low	
	Phase-A/B pulse train	PP·/PP			
		NP·/NP			

Options

■ Teaching pendant

[Features] This is a teaching device equipped with position input, test run, monitor, and other functions

[Model] CON-T-ENG (english version)

[Configuration]

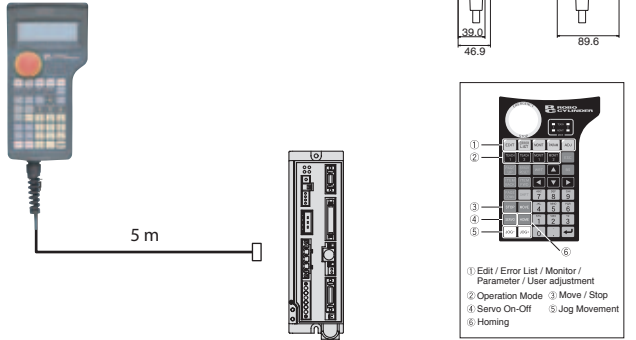

Name	Teaching Pendant
Model	CON-T-ENG (english version)
Protection grade	IP54
Applicable controllers	
Features	A standard, user-friendly teaching pendant equipped with a LCD screen.
Safety standard	CE
Display	20 characters x 4 lines on LCD
Weight	Approx. 400g
Cable length	5m
Ambient operating temperature, humidity	Temperature: 0~40°C, Humidity: 10~90% RH

■ PC software (for Windows only)

[Features] This is startup support software equipped with program/position input, test run, monitor, and other functions. It increases functions required for debugging operations and contributes to shortening the start-up time.

[Model] RCM-101-MW (with external device communications cable + RS232 converter unit).

[Configuration]

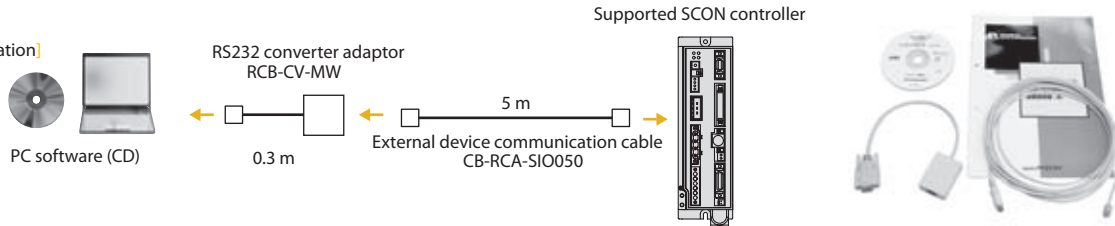

[Model] RCM-101-USB (with external device communications cable + USB cable).

[Configuration]

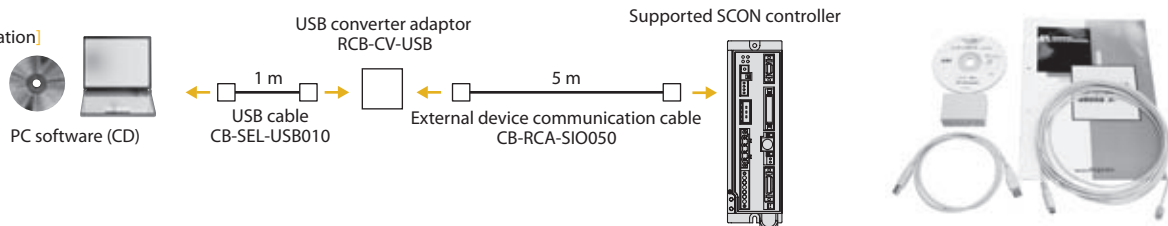

■ Regeneration resistance unit

[Features] This unit returns to heat the regeneration current generated when the motor decelerates. Check the operation direction and lead for the actuator operating in the table below and if regeneration resistance is required, prepare it.

[Model] REU-2

[Specifications]

Main unit weight	0.9 kg
Internal regeneration resistance value	220 Ω 80 W
Main unit – controller connection cable (accessory)	CB-SC-REU010 (for SSEL)

[Yardstick for required count]

	Lead 2.5 type	Lead 1.25 type
Horiz.	1	0
Vert.	1	1

* Depending on the operating conditions more regeneration resistance than above may be required.

[External dimension diagrams]

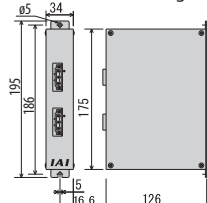

■ Absolute data storage battery

[Features] This battery is for storing absolute data when operating with an absolute specifications actuator

[Model] AB-5



Maintenance Parts

When it is necessary to make arrangements for a replacement cable or the like after product purchase, find the model below.

Motor cable / motor robot cable

Model CB-RCC-MA□□□ / CB-RCC-MA□□□-RB

* For □, enter the cable length (L), up to 30 meters, Example: 080 = 8 meters

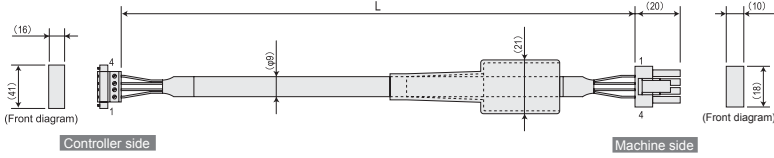

Wire	Color	Signal	No.	No.	Signal	Color	Wire
0.75sq	Green	PE	1	1	U	Red	0.75sq (press fit)
	Red	U	2	2	V	White	
	White	V	3	3	W	Black	
	Black	W	4	4	PE	Green	

Encoder cable / encoder robot cable

Model CB-RCS2-PLA□□□ / CB-X2-PLA□□□

* For □, enter the cable length (L), up to 30 meters, Example: 080 = 8 meters

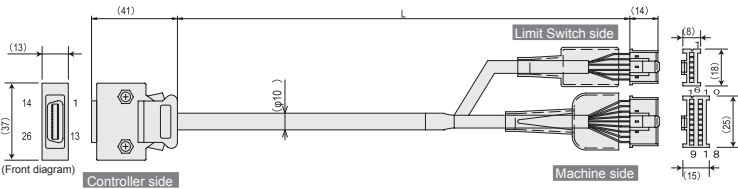

Wire	Color	Signal	No.	No.	Signal	Color	Wire
AWG26 (soldered)	White/orange	E24V	12	1	E24V	White/orange	AWG26 (press fit)
	White/green	OV	13	2	OV	White/green	
	Brown/blue	LS	26	3	LS	Brown/blue	
	Brown/yellow	CLEEP	25	4	CLEEP	Brown/yellow	
	Brown/red	OT	24	5	OT	Brown/red	
	Brown/black	BLCT	23	6	BLCT	Brown/black	
	—	—	9	7	—	—	
	—	—	18	8	—	—	
	—	—	19	9	—	—	
	—	—	10	10	—	—	
White/blue	A+	—	1	A	Wire	AWG26 (press fit)	
White/red	A-	—	2	A	Wire		
White/yellow	B+	—	3	B	Wire		
White/black	B-	—	4	B	Wire		
White/purple	Z+	—	5	Z	Wire		
White/gray	Z-	—	6	Z	Wire		
Orange	SRD+	—	7	—	—		
Green	SRD-	—	8	—	—		
Purple	B A T +	—	14	9	FG		Drain
Gray	B A T -	—	15	10	S D		Orange
Red	V C C	—	16	11	S D		Green
Black	G N D	—	17	12	B A T +		Purple
Blue	BKR-	—	21	13	B A T -		Gray
Yellow	BKR+	—	22	14	V C C		Red
—	—	—	—	15	G N D		Black
—	—	—	—	16	—		—
—	—	—	—	17	B K -		Blue
—	—	—	—	18	B K +		Yellow

I/O flat cable

Model CB-PAC-PIO□□□

* For □, enter the cable length (L), up to 30 meters, Example: 080 = 8 meters

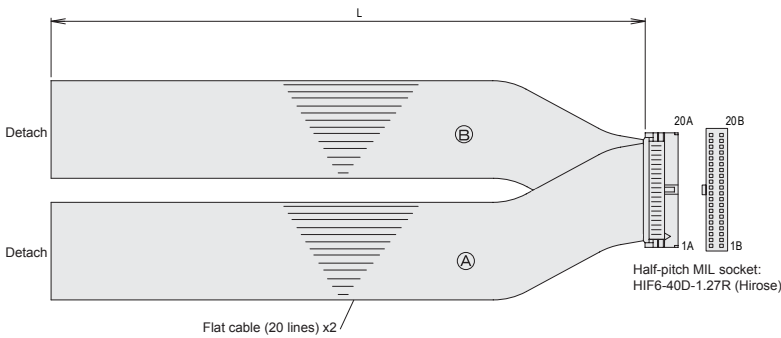

No.	Signal name	Cable Color	Wire	No.	Signal name	Cable Color	Wire
1A	24V	Brown - 1	Flat cable AWG26	1B	OUT0	Brown - 3	Flat cable AWG26
2A	24V	Red - 1		2B	OUT1	Red - 3	
3A	—	Orange - 1		3B	OUT2	Orange - 3	
4A	—	Yellow - 1		4B	OUT3	Yellow - 3	
5A	IN 0	Green - 1		5B	OUT4	Green - 3	
6A	IN 1	Blue - 1		6B	OUT5	Blue - 3	
7A	IN 2	Purple - 1		7B	OUT6	Purple - 3	
8A	IN 3	Gray - 1		8B	OUT7	Gray - 3	
9A	IN 4	White - 1		9B	OUT8	White - 3	
10A	IN 5	Black - 1		10B	OUT9	Black - 3	
11A	IN 6	Brown - 2		11B	OUT0	Brown - 4	
12A	IN 7	Red - 2		12B	OUT1	Red - 4	
13A	IN 8	Orange - 2		13B	OUT2	Orange - 4	
14A	IN 9	Yellow - 2		14B	OUT3	Yellow - 4	
15A	IN 10	Green - 2		15B	OUT4	Green - 4	
16A	IN 11	Blue - 2		16B	OUT5	Blue - 4	
17A	IN 12	Purple - 2		17B	—	Purple - 4	
18A	IN 13	Gray - 2		18B	—	Gray - 4	
19A	IN 14	White - 2		19B	OV	White - 4	
20A	IN 15	Black - 2		20B	OV	Black - 4	

SCON pulse string control cable

Model CB-SC-PIOS□□□

* For □, enter the cable length (L), up to 30 meters, Example: 080 = 8 meters

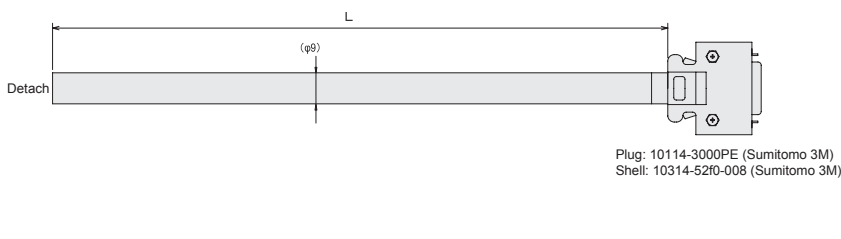

Wire	Color	Signal	No.
Black	Not used		1
White/black	Not used		2
Red	P P		3
White/red	/ P P		4
Green	N P		5
White/green	/ N P		6
Yellow	A F B		7
White/yellow	/ A F B		8
Brown	B F B		9
White/brown	/ B F B		10
Blue	Z F B		11
White/blue	/ Z F B		12
Gray	G N D		13
White/gray	G N D		14

RCS2-RA13R selection conditions ①

When this machine is used, it is necessary to fulfill the following three conditions.

- Condition 1. The pressing time must be no longer than the determined time.
- Condition 2. The continuous operating thrust for one cycle must be no greater than the actuator's rated thrust.
- Condition 3. There must be one pressing operation for one cycle.

■ Selection method

Condition 1. Pressing time

The maximum pressing time relative to each pressing command value is determined as in the table below. Always use a pressing time no greater than the time in the table below. If this machine is used in violation of the values in the table below, trouble may occur in the actuator.

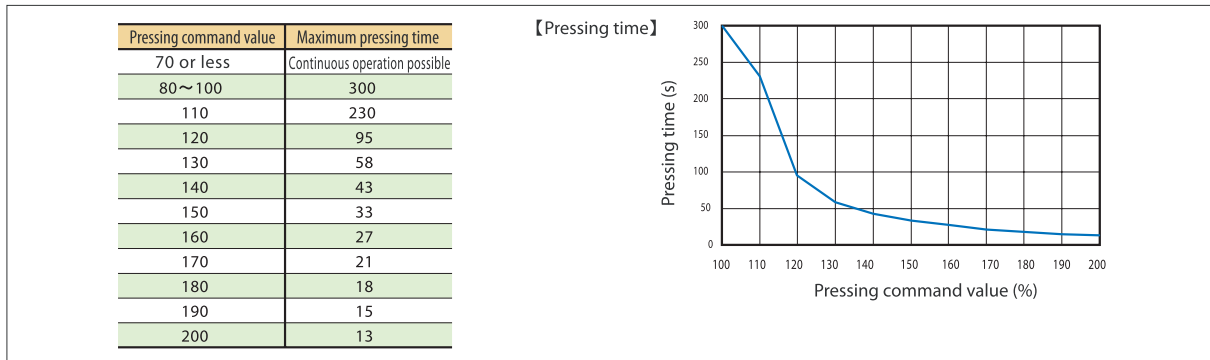

Condition 2. Continuous operation thrust

Check that the continuous operation thrust Ft for one cycle taking the load and duty ratio into account is less than the rated thrust of the ultra-high thrust actuator. There must be **one pressing operation** for one cycle.

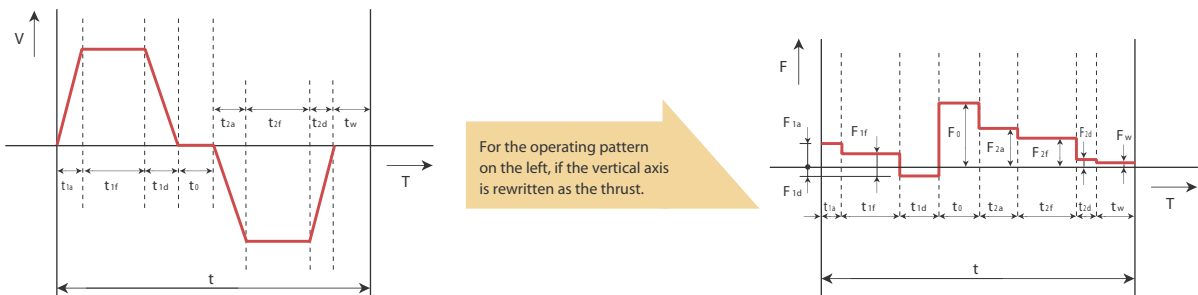

t : Operation time for one cycle (s)	t _{2a} : Acceleration time 2.
t _{1a} : Acceleration time 1.	t _{2f} : Constant-speed movement time 2.
t _{1f} : Constant-speed movement time 1.	t _{2d} : Deceleration time 2.
t _{1d} : Deceleration time 1.	t _w : Standby time
t ₀ : Pressing operation time	

F _{1a} : Thrust required for acceleration 1	F _{2a} : Thrust required for acceleration 2
F _{1f} : Thrust required for constant-speed movement 1	F _{2f} : Thrust required for constant-speed 2
F _{1d} : Thrust required for deceleration 1	F _{2d} : Thrust required for deceleration 2
F ₀ : Thrust required for pressing operation	F _w : Thrust required for standby

The continuous operation thrust Ft for one cycle is calculated from the equation below.

$$F_t = \sqrt{\frac{F_{1a}^2 \times t_{1a} + F_{1f}^2 \times t_{1f} + F_{1d}^2 \times t_{1d} + F_0^2 \times t_0 + F_{2a}^2 \times t_{2a} + F_{2f}^2 \times t_{2f} + F_{2d}^2 \times t_{2d} + F_w^2 \times t_w}{t}}$$

● F_{1a}/F_{2a}/F_{1d}/F_{2d} depend on the operation direction, so calculate with the equation below.

For horizontal use (acceleration/deceleration the same)	F _{1a} = F _{1d} = (M+m) × d
For vertical use Acceleration during descent	F _{1a} = (M+m) × 9.8 - (M+m) × d
For vertical use Constant-speed movement during descent	F _{1f} = (M+m) × 9.8 + α (*1)
For vertical use Deceleration during descent	F _{1d} = (M+m) × 9.8 + (M+m) × d
For vertical use Acceleration during ascent	F _{1a} = (M+m) × 9.8 + (M+m) × d
For vertical use Constant-speed movement during ascent	F _{1f} = (M+m) × 9.8 + α (*1)
For vertical use Deceleration during ascent	F _{1d} = (M+m) × 9.8 - (M+m) × d
For vertical use Standby	F _w = (M+m) × 9.8

- M : Moving section weight (kg)
- m : Load weight (kg)
- d : Command acceleration/deceleration (m/s²)
- α : Thrust taking the external guide traveling resistance into account

*1 When an external guide or the like is installed, it is necessary to take the traveling resistance into account.

Ultra-high thrust actuator
Moving section weight: 9 kg

Ultra-high thrust type selection conditions ②

- t_a is the acceleration time, but the calculation method is different for ① trapezoidal patterns and ② triangular patterns.

The difference between trapezoidal patterns and triangular patterns can be judged by whether the speed attained is greater or less than the set speed when the system is operated the movement distance with the set speed.

$$\text{Attained speed (Vmax)} = \sqrt{\text{movement distance (m)} \times \text{set acceleration (m/s}^2)}$$

Set speed < attained speed → ① Trapezoidal pattern

Set speed > attained speed → ② Triangular pattern

For ① Trapezoidal pattern

$$t_{\square a} = V_s / a \quad V_s : \text{Set speed (m/s)} \quad a : \text{Command acceleration (m/s}^2)$$

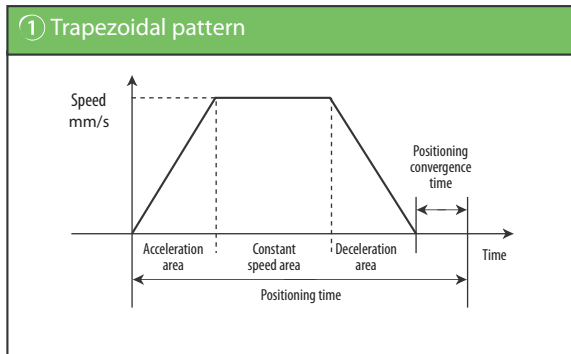

For ② Triangular pattern

$$t_{\square a} = V_s / a \quad V_s : \text{Attained speed (m/s)} \quad a : \text{Command acceleration (m/s}^2)$$

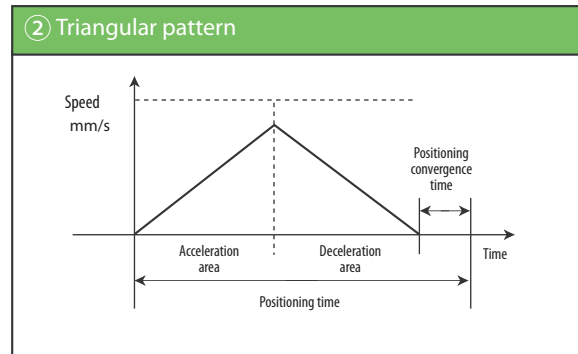

- $t_{\square f}$ is the constant-speed time. Calculate the distance traveled at constant speed.
 $t_{\square f} = L_c / V$ L_c : Distance traveled at constant speed (m) V : Command speed (m/s)
 * Distance traveled at constant speed = movement distance – acceleration distance – deceleration distance
 acceleration distance (deceleration distance) = $V^2 / 2a$
- $t_{\square d}$ is the deceleration time. If the acceleration and the deceleration are the same, then the deceleration time is the same as the acceleration time. $t_{\square d} = V/a$ V : Set speed (trapezoidal pattern) or attained speed (triangular pattern) (m/s) a : Command deceleration (m/s²)

If the continuous operation thrust F_t found this way is less than the rated thrust, the pattern can be run.

Ultra-high thrust actuator lead 2.5 type Rated thrust: 5100N

Ultra-high thrust actuator lead 1.25 type Rated thrust: 10200N

If the run conditions satisfy Condition 1 and Condition 2 above at the same time, the pattern can be operated. If either of the conditions can not be satisfied, take measures such as reducing the pressing operation time or lowering the duty ratio.

Example question

- Using the above selection method, try the operation pattern selection work.

Running conditions

- Machine type used : Ultra-high thrust actuator lead 1.25 type
- Installation posture : Vertical
- Speed : 62 mm/s
- Acceleration : 0.098m/s² (0.01G, same value for deceleration too)
- Movement distance : 50mm
- Loaded weight : 100kg
- Pressing command value : 200% (2000kgf)
- Pressing time : 3 s
- Standby time : 2 s

Also, the same operation conditions are set for ascent and descent. Graphing the above operation pattern gives the figure on the right.

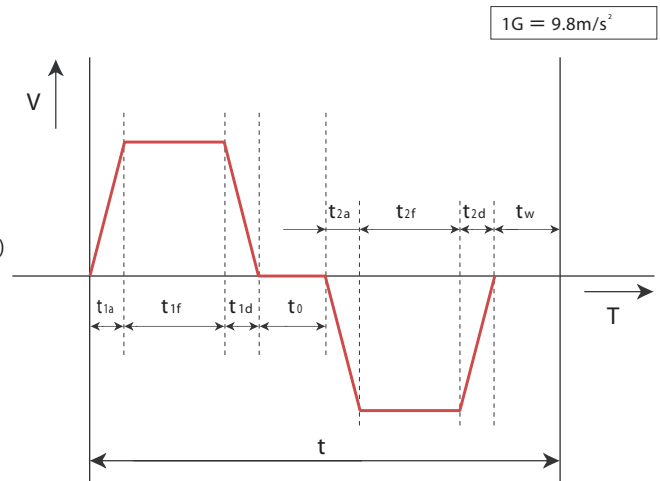

We will make the calculation according to the selection method.

Condition 1. Check the press operation time.

From Table 1 on Page 12, the pressing time was 3 seconds and the maximum pressing time is 13 seconds for a pressing command value of 200%, so this shows that the pressing time is OK.

Condition 2. Find the continuous operation thrust.

Substitute the above operation pattern into the above continuous operation thrust equation.

$$F_t = \sqrt{\frac{F_{1a}^2 \times t_{1a} + F_{1f}^2 \times t_{1f} + F_{1d}^2 \times t_{1d} + F_{0}^2 \times t_0 + F_{2a}^2 \times t_{2a} + F_{2f}^2 \times t_{2f} + F_{2d}^2 \times t_{2d} + F_w^2 \times t_w}{t}}$$

Here, when you check the operation $t_{1a}/t_{1d}/t_{2a}/t_{2d}$ operation pattern, the attained speed (V_{max}) = $\sqrt{0.05 \times 0.098} \rightarrow 0.07$ m/s, which is greater than the set speed of 62 mm/s (0.06 m/s), so the pattern becomes trapezoidal.

Therefore, $t_{1a}/t_{1d}/t_{2a}/t_{2d} = 0.062 \div 0.098 \rightarrow 0.63$ s.

Next, if t_{1f}/t_{2f} is calculated,

the distance traveled at constant speed = $0.05 - ((0.062 \times 0.062) \div (2 \times 0.098)) \times 2 \rightarrow 0.011$ m, so $t_{1f}/t_{2f} = 0.011 \div 0.062 \rightarrow 0.17$ s.

Also, if $F_{1a}/F_{1f}/F_{1d}/F_{2a}/F_{2f}/F_{2d}$ is calculated from the equation,

$$F_{1a} = F_{2d} = (9 + 100) \times 9.8 - (9 + 100) \times 0.098 \rightarrow 1058 \text{ N}$$

$$F_{1d} = F_{2a} = (9 + 100) \times 9.8 + (9 + 100) \times 0.098 \rightarrow 1079 \text{ N}$$

$$F_{1f} = F_{2f} = f_w = (9 + 100) \times 9.8 \rightarrow 1068 \text{ N}$$

Substituting the above numbers into the continuous operation thrust equation, gives

$$F_t = \sqrt{\frac{\{ (1058 \times 1058) \times 0.63 + (1068 \times 1068) \times 0.17 + (1079 \times 1079) \times 0.63 + (19600 \times 19600) \times 3 + (1079 \times 1079) \times 0.63 + (1068 \times 1068) \times 0.17 + (1058 \times 1058) \times 0.63 + (1068 \times 1068) \times 2 \}}{(0.63 + 0.17 + 0.63 + 3 + 0.63 + 0.17 + 0.63 + 2)}} \rightarrow 12113 \text{ N}$$

Since this exceeds the rated thrust of 10200 N for the ultra-high thrust actuator 2-ton type, this operating pattern can not be run.

So we try extending the standby time. (Lowering the duty ratio)

Here, if we recalculate with $t_w = 6.12$ s ($t = 12$ s), $F_t = 9814$ N and the pattern can be run.

Moment selection documentation

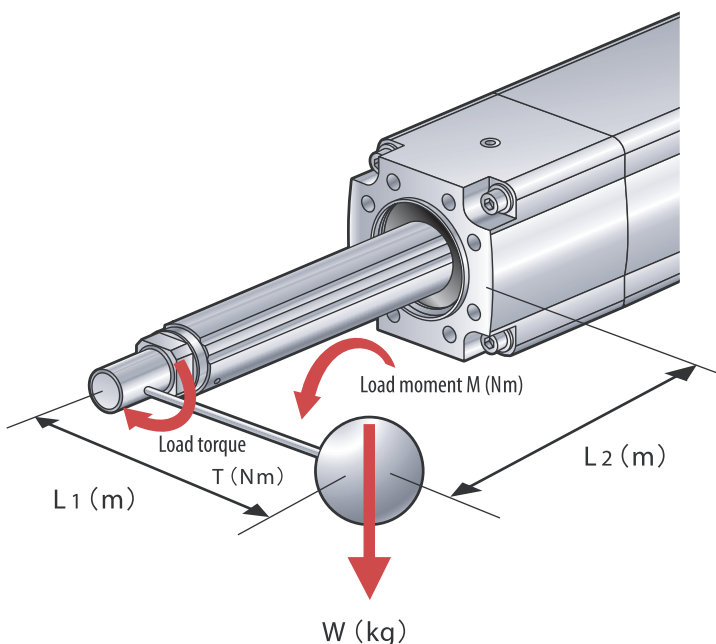

The ultra-high thrust actuator can apply load to the rod with the range of the conditions of the equations below.

$$M + T \leq 120 \text{ (Nm)}$$

$$\text{Load moment } M = W_g \times L_2$$

$$\text{Load torque } T = W_g \times L_1$$

* g = Acceleration due to gravity 9.8

* L_1 = Distance from the center of the rod to the center of gravity of the work

* L_2 = Distance from the actuator installation surface to the center of gravity of the work + 0.07

If the above conditions are not met, take load off the rod, for example by installing an external guide.

**RCS2-RA13R Series
Catalogue No. 0507-E**

The information contained in this catalog is subject to change without notice for the purpose of product improvement



Providing quality products
since 1986



IAI Industrieroboter GmbH
Ober der Röth 4
D-65824 Schwalbach / Frankfurt
Germany
Tel.: +49-6196-8895-0
Fax: +49-6196-8895-24
E-Mail: info@IAI-GmbH.de
Internet: <http://www.eu.IAI-GmbH.de>

IAI America Inc.

2690 W. 237th Street, Torrance, CA 90505, U.S.A
Tel.: +1-310-891-6015 Fax: +1-310-891-0815

IAI CORPORATION

645-1 Shimizu Hirose, Shizuoka 424-0102, Japan
Tel.: +81-543-64-5105 Fax: +81-543-64-5182