

ELECYLINDER®

3 Position Mode Specification

Instruction Manual **First Edition** ME3837-1D



Configuration and Wiring	ch.1
Operation	ch.2
Parameter	ch.3

Please Read Before Use

Thank you for purchasing our product.

This manual describes the 3 position (3-point positioning) mode specification of ELECYLINDER. The 3 position (3-point positioning) mode specification is to be selected with the option symbol MF in the model code.

For the mechanical specifications or how to install the product, or for maintenance and inspection works, refer to [Instruction Manual for ELECYLINDER Type to Use].

For the electrical / control categories that are not described in this manual such as the electrical specifications, wirings, connections, parameters or control, or how to perform error processes, refer to the separate volume [ELECYLINDER Electric Edition Instruction Manual (ME3816)].

Before using the product, be sure to read this manual and fully understand the contents explained herein to ensure safe use of the product.

Please download the user's manual from our website.

You can download it free of charge. User registration is required for the first time downloading.

URL : www.iai-robot.co.jp/data_dl/CAD_MANUAL/

When using the product, print out of the necessary portions of the relevant manual, or please display it on your computer, tablet terminal, etc. so that you can check it immediately.

After reading the instruction manual, keep it in a convenient place so that whoever is handling the product can refer to it quickly when necessary.

[Important]

- This instruction manual is an original document dedicated for this product.
- This product cannot be used in ways not shown in this instruction manual. IAI shall not be liable for any result whatsoever arising from the use of the product in any other way than what is noted in the manual.
- The information contained in this instruction manual is subject to change without notice for the purpose of product improvement.
- If any issues arise regarding the information contained in this instruction manual, contact our customer center or the nearest sales office.
- Use or reproduction of this instruction manual in full or in part without permission is prohibited.
- The company names, names of products and trademarks of each company shown in the text are registered trademarks.

Contents

Safety Guide	Intro-1
Precautions for Handling	Intro-9
Chapter 1 Configuration and Wiring	
1.1 Example of System Configuration	1-1
1.2 Connection Arrangement Diagram	1-2
1.3 Cable and Connector	1-4
1.3.1 Power & I/O Cable	1-4
1.3.2 Power & I/O Connector	1-7
1.3.3 Power & I/O Cable (For RCON-EC connection specification)	1-8
1.3.4 Connecting the EC to the Power & I/O Cable	1-10
1.4 Way of Wiring	1-11
1.4.1 PLC Wiring (for connect to PIO control / connector)	1-11
1.4.2 PLC Wiring (for connect to PIO control / cables)	1-14
1.4.3 EC Connection Unit Wiring	1-15
1.5 Teaching Tool	1-16
1.6 EC Connection Unit	1-18
Chapter 2 Operation	
2.1 Basic Operation	2-1
2.1.1 Operating Method of ELECYLINDER	2-1
2.1.2 Simple Data Setting Window	2-2
2.1.3 DIGITAL SPEED CONTROLLER Window Display	2-7
2.1.4 Operation with a JOG Switch	2-8
2.2 I/O signals	2-9
2.2.1 I/O Signal Assignment	2-9
2.2.2 I/O Signal List	2-11
2.2.3 3-point Positioning "ST0", "ST1" Signals: Movement Command Input (backward/forward/middle point)	2-12
2.2.4 "LS0", "LS1", "LS2" Signals: Position Detection Output (backward end/forward end/middle point)	2-14
2.3 Operating Method from Master Device	2-16
Chapter 3 Parameters	
3.1 Parameters	3-1
3.1.1 Parameter No.9: Electromagnetic Valve System Select	3-1
3.1.2 Parameter No.10: LED Lighting System Automatic Switch Setting	3-1
Revision History	Post-1

Safety Guide

“Safety Guide” has been written to use the machine safely and so prevent personal injury or property damage beforehand. Make sure to read it before the operation of this product.

Safety Precautions for Our Products

The common safety precautions for the use of any of our robots in each operation.

No.	Operation Description	Description
1	Model Selection	<ul style="list-style-type: none"> ● This product has not been planned and designed for the application where high level of safety is required, so the guarantee of the protection of human life is impossible. Accordingly, do not use it in any of the following applications. <ol style="list-style-type: none"> 1) Medical equipment used to maintain, control or otherwise affect human life or physical health. 2) Mechanisms and machinery designed for the purpose of moving or transporting people (For vehicle, railway facility or air navigation facility) 3) Important safety parts of machinery (Safety device, etc.) ● Do not use the product outside the specifications. Failure to do so may considerably shorten the life of the product. ● Do not use it in any of the following environments. <ol style="list-style-type: none"> 1) Location where there is any inflammable gas, inflammable object or explosive 2) Place with potential exposure to radiation 3) Location with the ambient temperature or relative humidity exceeding the specification range 4) Location where radiant heat is added from direct sunlight or other large heat source 5) Location where condensation occurs due to abrupt temperature changes 6) Location where there is any corrosive gas (sulfuric acid or hydrochloric acid) 7) Location exposed to significant amount of dust, salt or iron powder 8) Location subject to direct vibration or impact ● For an actuator used in vertical orientation, select a model which is equipped with a brake. If selecting a model with no brake, the moving part may drop when the power is turned OFF and may cause an accident such as an injury or damage on the work piece.

No.	Operation Description	Description
2	Transportation	<ul style="list-style-type: none"> ● When carrying a heavy object, do the work with two or more persons or utilize equipment such as crane. ● When the work is carried out with 2 or more persons, make it clear who is to be the “leader” and who to be the “follower(s)” and communicate well with each other to ensure the safety of the workers. ● When in transportation, consider well about the positions to hold, weight and weight balance and pay special attention to the carried object so it would not get hit or dropped. ● Transport it using an appropriate transportation measure. The actuators available for transportation with a crane have eyebolts attached or there are tapped holes to attach bolts. Follow the instructions in the instruction manual for each model. ● Do not step or sit on the package. ● Do not put any heavy thing that can deform the package, on it. ● When using a crane capable of 1t or more of weight, have an operator who has qualifications for crane operation and sling work. ● When using a crane or equivalent equipments, make sure not to hang a load that weighs more than the equipment’s capability limit. ● Use a hook that is suitable for the load. Consider the safety factor of the hook in such factors as shear strength. ● Do not get on the load that is hung on a crane. ● Do not leave a load hung up with a crane. ● Do not stand under the load that is hung up with a crane.
3	Storage and Preservation	<ul style="list-style-type: none"> ● The storage and preservation environment conforms to the installation environment. However, especially give consideration to the prevention of condensation. ● Store the products with a consideration not to fall them over or drop due to an act of God such as earthquake.
4	Installation and Start	<p>(1) Installation of Robot Main Body and Controller, etc.</p> <ul style="list-style-type: none"> ● Make sure to securely hold and fix the product (including the work part). A fall, drop or abnormal motion of the product may cause a damage or injury. Also, be equipped for a fall-over or drop due to an act of God such as earthquake. ● Do not get on or put anything on the product. Failure to do so may cause an accidental fall, injury or damage to the product due to a drop of anything, malfunction of the product, performance degradation, or shortening of its life. ● When using the product in any of the places specified below, provide a sufficient shield. <ol style="list-style-type: none"> 1) Location where electric noise is generated 2) Location where high electrical or magnetic field is present 3) Location with the mains or power lines passing nearby 4) Location where the product may come in contact with water, oil or chemical droplets

No.	Operation Description	Description
4	Installation and Start	<p>(2) Cable Wiring</p> <ul style="list-style-type: none"> ● Use our company's genuine cables for connecting between the actuator and controller, and for the teaching tool. ● Do not scratch on the cable. Do not bend it forcibly. Do not pull it. Do not coil it around. Do not insert it. Do not put any heavy thing on it. Failure to do so may cause a fire, electric shock or malfunction due to leakage or continuity error. ● Perform the wiring for the product, after turning OFF the power to the unit, so that there is no wiring error. ● When the direct current power (+24V) is connected, take the great care of the directions of positive and negative poles. If the connection direction is not correct, it might cause a fire, product breakdown or malfunction. ● Connect the cable connector securely so that there is no disconnection or looseness. Failure to do so may cause a fire, electric shock or malfunction of the product. ● Never cut and/or reconnect the cables supplied with the product for the purpose of extending or shortening the cable length. Failure to do so may cause the product to malfunction or cause fire. <p>(3) Grounding</p> <ul style="list-style-type: none"> ● The grounding operation should be performed to prevent an electric shock or electrostatic charge, enhance the noise-resistance ability and control the unnecessary electromagnetic radiation. ● For the ground terminal (PE) on the AC power cable of the controller and the grounding plate in the control panel, make sure for grounding work. For security grounding, it is necessary to select an appropriate wire thickness suitable for the load. Perform wiring that satisfies the specifications (electrical equipment standards and criteria). For detail, follow the description in [an instruction manual of each controller or controller built-in actuator]. ● Conduct functional grounding on the FG terminal for a controller supplying 24V DC or a controller built-in type actuator. In order to minimize influence to mechanical operation given by electromagnetic interference (noise) to an electrical device or insulation failure, conduct grounding on a terminal or a conductor that is electrically stable. The reference impedance should be Type D (Former Class 3, ground resistance 100Ω or less).





No.	Operation Description	Description
4	Installation and Start	<p>(4) Safety Measures</p> <ul style="list-style-type: none"> ● When the work is carried out with 2 or more persons, make it clear who is to be the “leader” and who to be the “follower(s)” and communicate well with each other to ensure the safety of the workers. ● When the product is under operation or in the ready mode, take the safety measures (such as the installation of safety and protection fence) so that nobody can enter the area within the robot’s movable range. When the robot under operation is touched, it may result in death or serious injury. ● Make sure to install the emergency stop circuit so that the unit can be stopped immediately in an emergency during the unit operation. ● Take the safety measure not to start up the unit only with the power turning ON. Failure to do so may start up the machine suddenly and cause an injury or damage to the product. ● Take the safety measure not to start up the machine only with the emergency stop cancellation or recovery after the power failure. Failure to do so may result in an electric shock or injury due to unexpected power input. ● When the installation or adjustment operation is to be performed, give clear warnings such as “Under Operation; Do not turn ON the power!” etc. Sudden power input may cause an electric shock or injury. ● Take the measure so that the work part is not dropped in power failure or emergency stop. ● Wear protection gloves, goggle or safety shoes, as necessary, to secure safety. ● Do not insert a finger or object in the openings in the product. Failure to do so may cause an injury, electric shock, damage to the product or fire. ● When releasing the brake on a vertically oriented actuator, exercise precaution not to pinch your hand or damage the work parts with the actuator dropped by gravity.
5	Teaching	<ul style="list-style-type: none"> ● When the work is carried out with 2 or more persons, make it clear who is to be the “leader” and who to be the “follower(s)” and communicate well with each other to ensure the safety of the workers. ● Perform the teaching operation from outside the safety protection fence, if possible. In the case that the operation is to be performed unavoidably inside the safety protection fence, prepare the “Stipulations for the Operation” and make sure that all the workers acknowledge and understand them well. ● When the operation is to be performed inside the safety protection fence, the worker should have an emergency stop switch at hand with him so that the unit can be stopped any time in an emergency. ● When the operation is to be performed inside the safety protection fence, in addition to the workers, arrange a watchman so that the machine can be stopped any time in an emergency. Also, keep watch on the operation so that any third person can not operate the switches carelessly. ● Place a sign “Under Operation” at the position easy to see. ● When releasing the brake on a vertically oriented actuator, exercise precaution not to pinch your hand or damage the work parts with the actuator dropped by gravity. <p>* Safety protection Fence : In the case that there is no safety protection fence, the movable range should be indicated.</p>

No.	Operation Description	Description
6	Trial Operation	<ul style="list-style-type: none"> ● When the work is carried out with 2 or more persons, make it clear who is to be the “leader” and who to be the “follower(s)” and communicate well with each other to ensure the safety of the workers. ● After the teaching or programming operation, perform the check operation one step by one step and then shift to the automatic operation. ● When the check operation is to be performed inside the safety protection fence, perform the check operation using the previously specified work procedure like the teaching operation. ● Make sure to perform the programmed operation check at the safety speed. Failure to do so may result in an accident due to unexpected motion caused by a program error, etc. ● Do not touch the terminal block or any of the various setting switches in the power ON mode. Failure to do so may result in an electric shock or malfunction.
7	Automatic Operation	<ul style="list-style-type: none"> ● Check before starting the automatic operation or rebooting after operation stop that there is nobody in the safety protection fence. ● Before starting automatic operation, make sure that all peripheral equipment is in an automatic-operation-ready state and there is no alarm indication. ● Make sure to operate automatic operation start from outside of the safety protection fence. ● In the case that there is any abnormal heating, smoke, offensive smell, or abnormal noise in the product, immediately stop the machine and turn OFF the power switch. Failure to do so may result in a fire or damage to the product. ● When a power failure occurs, turn OFF the power switch. Failure to do so may cause an injury or damage to the product, due to a sudden motion of the product in the recovery operation from the power failure.

No.	Operation Description	Description
8	Maintenance and Inspection	<ul style="list-style-type: none"> ● When the work is carried out with 2 or more persons, make it clear who is to be the “leader” and who to be the “follower(s)” and communicate well with each other to ensure the safety of the workers. ● Perform the work out of the safety protection fence, if possible. In the case that the operation is to be performed unavoidably inside the safety protection fence, prepare the “Stipulations for the Operation” and make sure that all the workers acknowledge and understand them well. ● When the work is to be performed inside the safety protection fence, basically turn OFF the power switch. ● When the operation is to be performed inside the safety protection fence, the worker should have an emergency stop switch at hand with him so that the unit can be stopped any time in an emergency. ● When the operation is to be performed inside the safety protection fence, in addition to the workers, arrange a watchman so that the machine can be stopped any time in an emergency. Also, keep watch on the operation so that any third person can not operate the switches carelessly. ● Place a sign “Under Operation” at the position easy to see. ● For the grease for the guide or ball screw, use appropriate grease according to the instruction manual for each model. ● Do not perform the dielectric strength test. Failure to do so may result in a damage to the product. ● When releasing the brake on a vertically oriented actuator, exercise precaution not to pinch your hand or damage the work parts with the actuator dropped by gravity. ● The slider or rod may get misaligned OFF the stop position if the servo is turned OFF. Be careful not to get injured or damaged due to an unnecessary operation. ● Pay attention not to lose the removed cover or screws, and make sure to put the product back to the original condition after maintenance and inspection works. <p>Use in incomplete condition may cause damage to the product or an injury.</p> <p>* Safety protection Fence : In the case that there is no safety protection fence, the movable range should be indicated.</p>
9	Modification and Dismantle	<ul style="list-style-type: none"> ● Do not modify, disassemble, assemble or use of maintenance parts not specified based at your own discretion.
10	Disposal	<ul style="list-style-type: none"> ● When the product becomes no longer usable or necessary, dispose of it properly as an industrial waste. ● When removing the actuator for disposal, pay attention to drop of components when detaching screws. ● Do not put the product in a fire when disposing of it. The product may burst or generate toxic gases.
11	Other	<ul style="list-style-type: none"> ● Do not come close to the product or the harnesses if you are a person who requires a support of medical devices such as a pacemaker. Doing so may affect the performance of your medical device. ● See Overseas Specifications Compliance Manual to check whether complies if necessary. ● For the handling of actuators and controllers, follow the dedicated instruction manual of each unit to ensure the safety.

Alert Indication

The safety precautions are divided into “Danger”, “Warning”, “Caution” and “Notice” according to the warning level, as follows, and described in the instruction manual for each model.

Level	Degree of Danger and Damage	Symbol
Danger	This indicates an imminently hazardous situation which, if the product is not handled correctly, will result in death or serious injury.	 Danger
Warning	This indicates a potentially hazardous situation which, if the product is not handled correctly, could result in death or serious injury.	 Warning
Caution	This indicates a potentially hazardous situation which, if the product is not handled correctly, may result in minor injury or property damage.	 Caution
Notice	This indicates lower possibility for the injury, but should be kept to use this product properly.	 Notice

Precautions for Handling

1. The Safety Guide attached with the product is intended to permit safe use of the product and thus to prevent risks and property damage. Be sure to read it before handling the product.

2. This manual describes the 3 position (3-point positioning) mode specification of ELECYLINDER. The 3 position (3-point positioning) mode specification is to be selected with the option symbol MF in the model code.
 For the mechanical specifications or how to install the product, or for maintenance and inspection works, refer to [Instruction Manual for ELECYLINDER Type to Use]. For the electrical / control categories that are not described in this manual such as the electrical specifications, wirings, connections, parameters or control, or how to perform error processes, refer to the separate volume [ELECYLINDER Electric Edition Instruction Manual (ME3816)].

3. Do not attempt any handling or operation that is not indicated in this instruction manual.

4. Make sure to observe the usage conditions and environment of the product.
 Operation outside the warranty could cause decreased performance or product breakdown.
 Use within the allowable range for each item.

Item	Cautions for use	Problems or breakdowns which may occur if the allowable range is exceeded
Speed and acceleration/deceleration	Use within the allowable range	May lead to abnormal noise, vibration, breakdown, or shortened product life.
Allowable load moment	Use within the allowable range (Static/dynamic)	May lead to abnormal noise, vibration, breakdown, or shortened product life. In extreme cases, flaking may occur on the guide or ball screw.
Overhang load length		Mounting a load with an overhang length greater than the allowable values may lead to vibration or abnormal noise.

5. The "pressing operation" cannot be set at the Middle point.
6. When accuracy in the middle point stop is required, have the both signals of forward and backward kept on.
7. In case ACR (RCON-EC connection specification) option is to be used, confirm that the firmware of the EC connection unit to be connected is "V0009" or later. Operation in normal condition cannot be performed with an old version.

**3 position mode
specification**

Chapter 1

Configuration and Wiring

1.1	Example of System Configuration	1-1
1.2	Connection Arrangement Diagram	1-2
1.3	Cable and Connector	1-4
1.3.1	Power & I/O Cable	1-4
1.3.2	Power & I/O Connector	1-7
1.3.3	Power & I/O Cable (For RCON-EC connection specification) ·	1-8
1.3.4	Connecting the EC to the Power & I/O Cable	1-10
1.4	Way of Wiring	1-11
1.4.1	PLC Wiring (for connect to PIO control / connector)	1-11
1.4.2	PLC Wiring (for connect to PIO control / cables)	1-14
1.4.3	EC Connection Unit Wiring	1-15
1.5	Teaching Tool	1-16
1.6	EC Connection Unit	1-18

1.1 Example of System Configuration

Reference

- For electric / control details such as electrical specification, wiring, connection, parameters and how to control, and also how to treat errors, refer to [ELECYLINDER Electricity Section Instruction Manual (ME3816)] provided separately.

The following shows the system configuration.

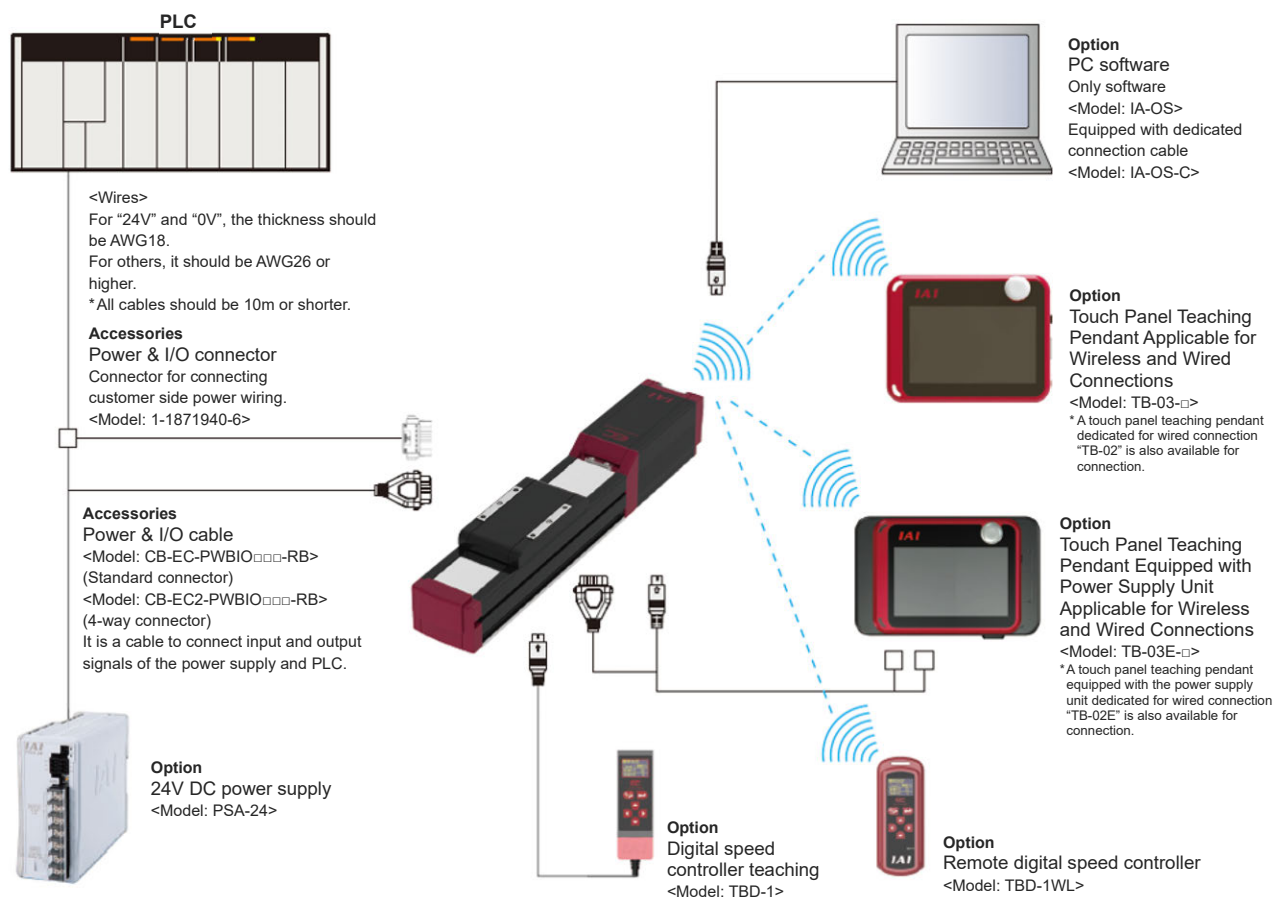

Supply 24V DC to the ELECYLINDER and input a signal from a master device to the ELECYLINDER.

This enables the ELECYLINDER to operate.

This manual introduces an example using a PLC connected as the master device.

1.2 Connection Arrangement Diagram

Here introduces how to wire when using a power supply cable & I/O connector.

⊙ Standard specification

◆ For NPN specification

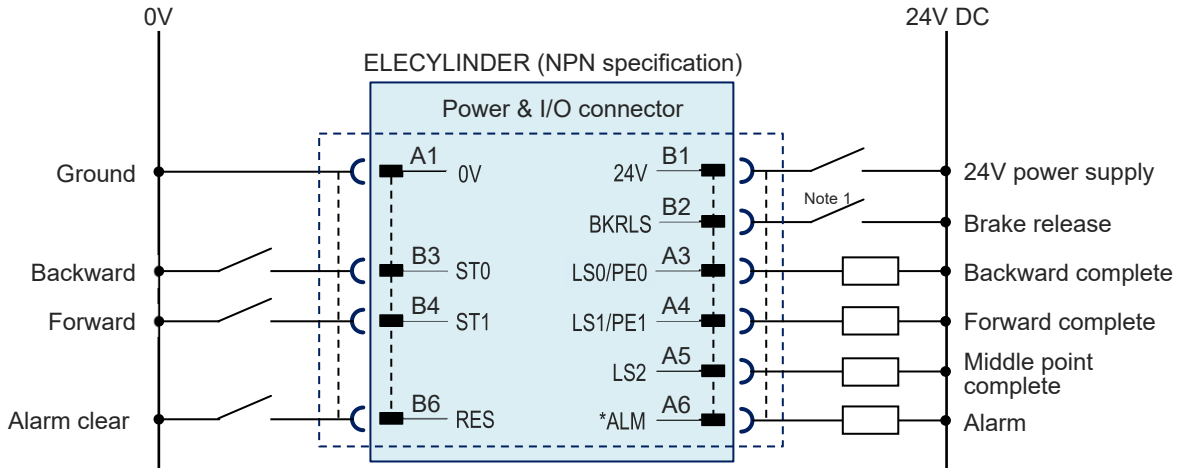

◆ For PNP specification

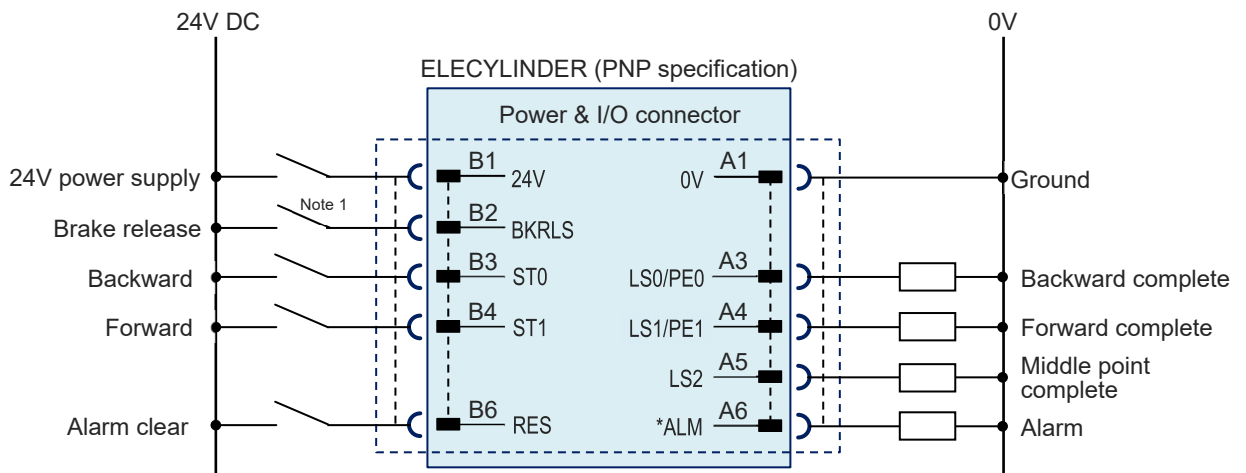

Caution

- "Note 1" is a switch releases the brake forcibly for actuators equipped with a brake. The switch power capacity requires 24V DC $\pm 10\%$ and 200mA or more.
- "**ALM" is a b-contact (active-low) signal. The output signal is ON in normal conditions and OFF when an alarm occurs.

◎ 2-circuit power supply specification TMD2 (Option)

◆For NPN specification

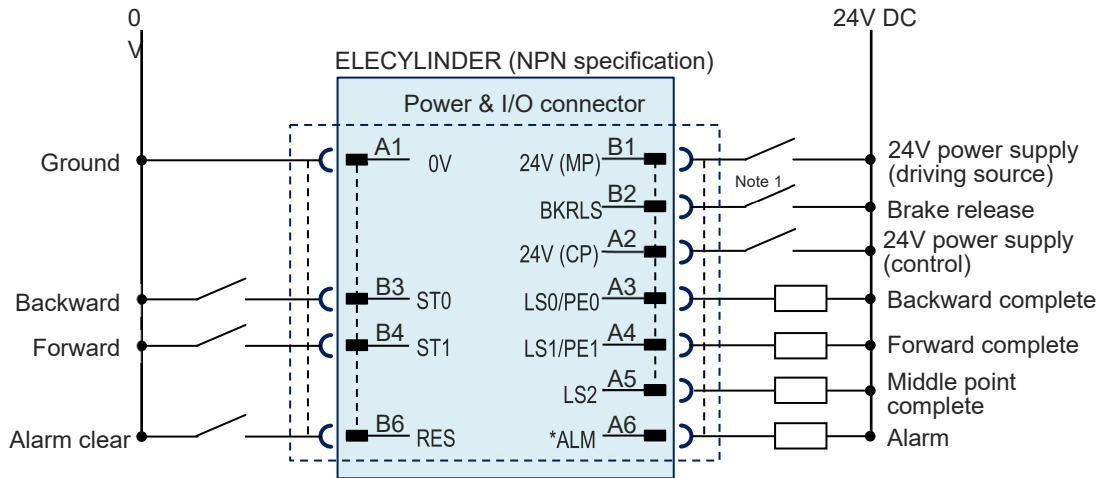

◆For PNP specification

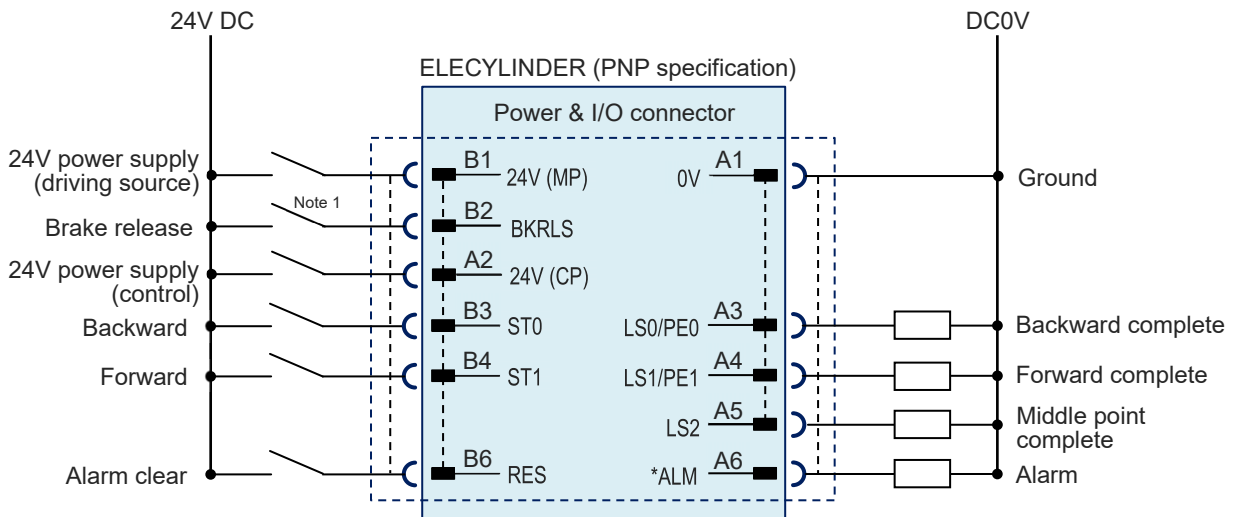

Caution

- "Note 1" is a switch releases the brake forcibly for actuators equipped with a brake. The switch power capacity requires 24V DC ±10% and 200mA or more.
- "**ALM" is a b-contact (active-low) signal. The output signal is ON in normal conditions and OFF when an alarm occurs.

1.3 Cable and Connector

1.3.1 Power & I/O Cable

[1] Power & I/O Cable

Model **CB-EC-PWBIO**□□□-**RB**

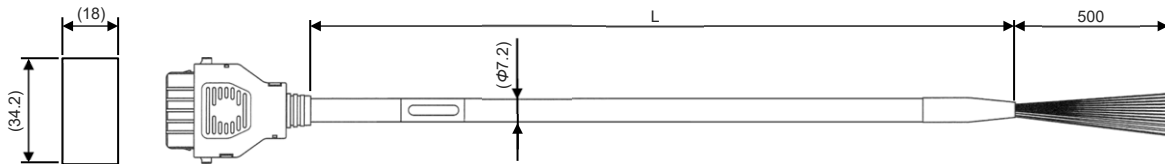

Minimum bending radius 58mm (for movable use)

* Robot cable is standard for this model.

Color	Signal name	Pin No.
Black (AWG18)	0V	A1
Red (AWG18)	24V	B1
Light blue (AWG22)	(Reserve) ^{Note 1}	A2
Orange (AWG26)	ST0	B3
Yellow (AWG26)	ST1	B4
Green (AWG26)	Reserve	B5
Pink (AWG26)	RES	B6
Blue (AWG26)	LS0/PE0	A3
Purple (AWG26)	LS1/PE1	A4
Gray (AWG26)	LS2	A5
White (AWG26)	* ALM	A6
Brown (AWG26)	BKRLS	B2

Note 1 TMD2 is 24V (control)

(Note) Cable in Yellow green and light gray not in us.
(Already cut inside shrink tube)

- The wiring on the opposite side of the connector has not been processed.
- The cable length (L) is available from 1m to 10m. Specify the length in increments of 1m.
- Sample model number : Cable length **3**m → **CB-EC-PWBIO030-RB**

[2] Power & I/O Cable (user wiring specification, 4-way connector)

Model **CB-EC2-PWBIO□□□-RB**

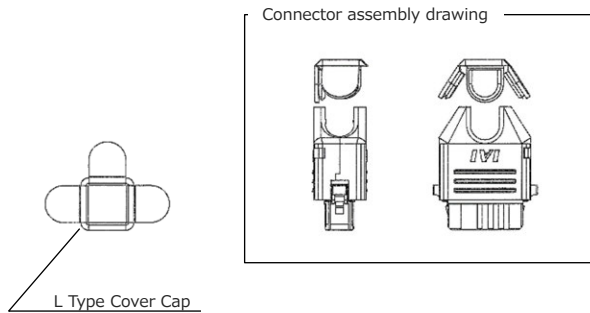
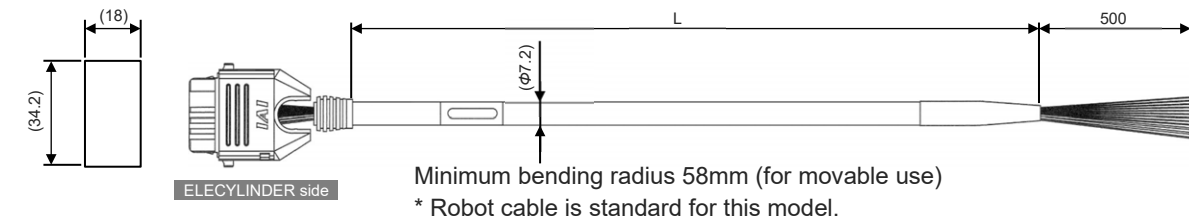

Color	Signal name	Pin No.
Black (AWG18)	0V	A1
Red (AWG18)	24V	B1
Light blue (AWG22)	(Reserve) ^(Note 1)	A2
Orange (AWG26)	ST0	B3
Yellow (AWG26)	ST1	B4
Green (AWG26)	Reserve	B5
Pink (AWG26)	RES	B6
Blue (AWG26)	LS0/PE0	A3
Purple (AWG26)	LS1/PE1	A4
Gray (AWG26)	LS2	A5
White (AWG26)	* ALM	A6
Brown (AWG26)	BKRLS	B2

Note 1 TMD2 is 24V (control)

(Note) Cable in Yellow green and light gray not in us.
(Already cut inside shrink tube)

- The wiring on the opposite side of the connector has not been processed.
- The cable length (L) is available from 1m to 10m. Specify the length in increments of 1m.
- Sample model number : Cable length **3m** → CB-EC2-PWBIO**030**-RB

[3] About 4-way Connector

It is a cable capable to change the orientation of the connector in 4-way.

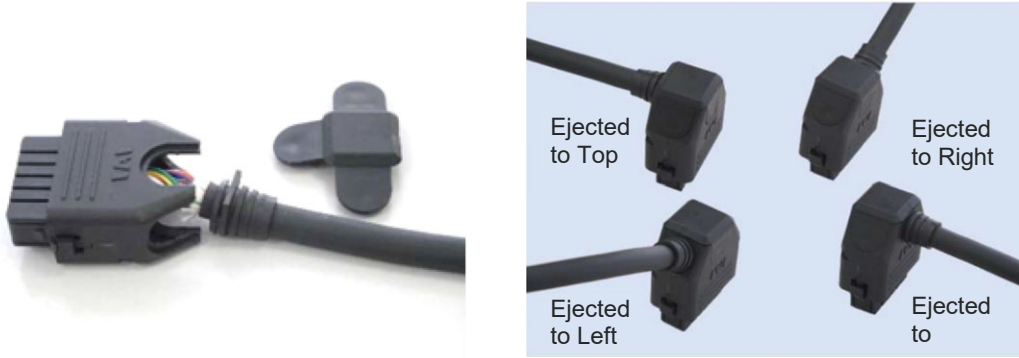

Follow the process bellow to build up the connector in the orientation of your demand.

- 1) Insert the cable by sliding it from the curved side of the cable-end to your desire direction.

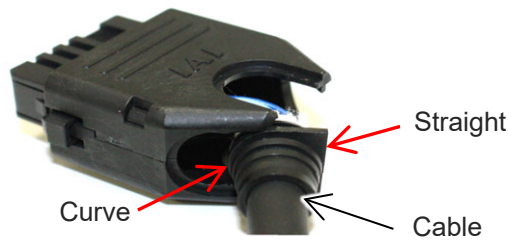

- 2) Be sure to check that the cable is settled firmly and insert two tabs of the cover along the slits of socket.



- 3) Then, push the last tab to the socket.



1.3.2 Power & I/O Connector

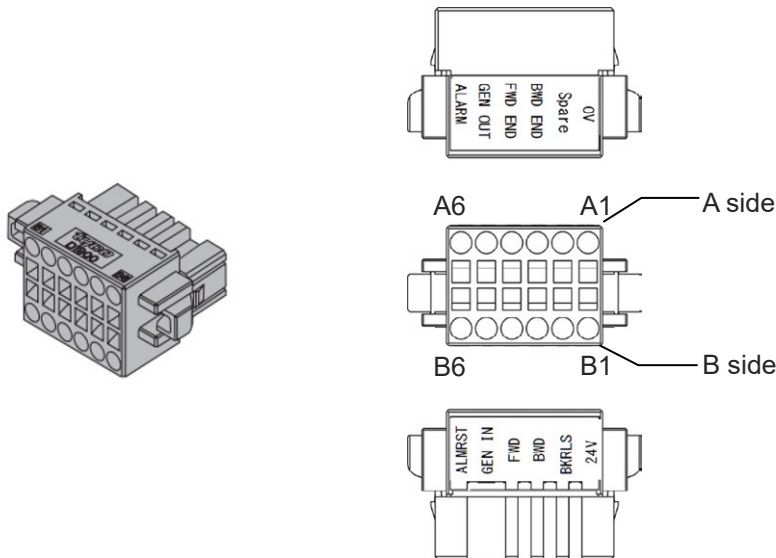

Name	Model	Quantity
Power & I/O connector	1-1871940-6-MF	1 pc

Pin No.	Nameplate name	Function
A1	0V	Ground
A2	Spare (CP: 2-circuit power supply specification)	Spare (24V for control power supply when power supply 2-system specification)
A3	BWD END	Backward completion (Pressing complete 0 when pressing operation)
A4	FWD END	Forward completion (Pressing complete 1 when pressing operation)
A5	General OUT	Middle point completion
A6	Alarm	Alarm output
B1	24V (MP: 2-circuit power supply specification)	24V power supply (24V for motor power supply when power supply 2-system specification)
B2	BKRLS	Brake release input
B3	BWD	Backward command
B4	FWD	Forward command
B5	General IN	Spare
B6	ALMRST	Alarm clear signal input

* Input B3 and B4 simultaneously and middle point drive can be made.

1.3.3 Power & I/O Cable (For RCON-EC connection specification)

[1] Power & I/O Cable (Standard specification)

Model **CB-REC-PWBIO□□□-RB**

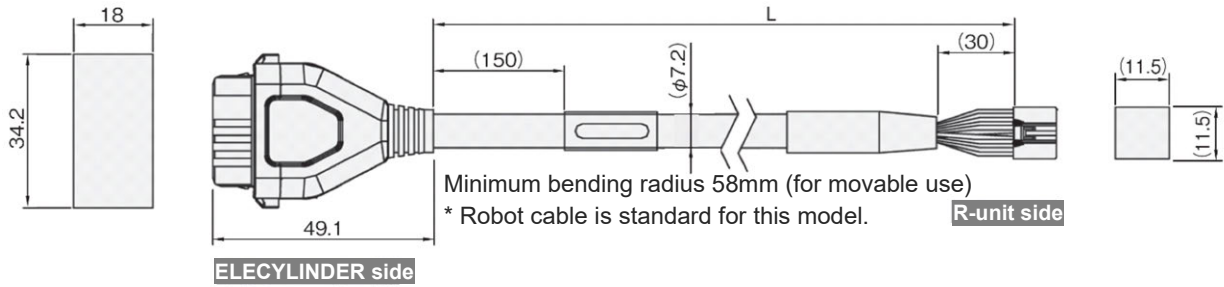

3-1871946-6

DF62C-13S-2.2C(18)

Color	Signal name	Pin No.	Pin No.	Signal name	Color
Black (AWG18)	0V	A1	2	0V	Black (AWG18)
Red (AWG18)	24V (MP)	B1	1	24V (MP)	Red (AWG18)
Light blue (AWG22)	24V (CP)	A2	12	24V (CP)	Light blue (AWG22)
Orange (AWG26)	IN0	B3	7	OUT0	Orange (AWG26)
Yellow (AWG26)	IN1	B4	8	OUT1	Yellow (AWG26)
Green (AWG26)	IN2	B5	9	OUT2	Green (AWG26)
Yellow green (AWG26)	SD+	B6	6	SD+	Yellow green (AWG26)
Light gray (AWG26)	SD-	A6	10	SD-	Light gray (AWG26)
Blue (AWG26)	OUT0	A3	3	IN0	Blue (AWG26)
Purple (AWG26)	OUT1	A4	4	IN1	Purple (AWG26)
Gray (AWG26)	OUT2	A5	5	IN2	Gray (AWG26)
Brown (AWG26)	BKRLS	B2	11	BKRLS	Brown (AWG26)
			13	FG	Green (AWG26)

- The cable length (L) is available from 1m to 10m. Specify the length in increments of 1m.
- Sample model number : Cable length 3m → CB-REC-PWBIO030-RB

[2] Power & I/O Cable (4-way Connector specification)

Model **CB-REC2-PWBIO□□□-RB**

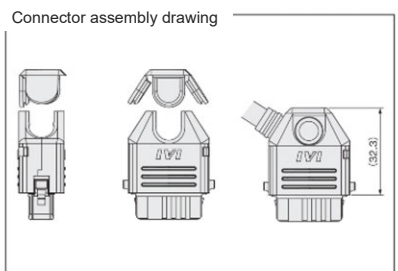
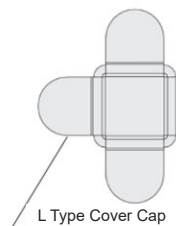
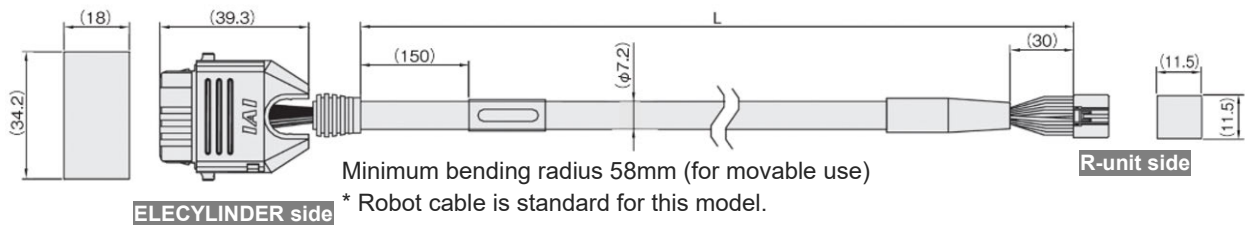

3-1871946-6

DF62C-13S-2.2C(18)

Color	Signal name	Pin No.
Black (AWG18)	0V	A1
Red (AWG18)	24V (MP)	B1
Light blue (AWG22)	24V (CP)	A2
Orange (AWG26)	IN0	B3
Yellow (AWG26)	IN1	B4
Green (AWG26)	IN2	B5
Yellow green (AWG26)	SD+	B6
Light gray (AWG26)	SD-	A6
Blue (AWG26)	OUT0	A3
Purple (AWG26)	OUT1	A4
Gray (AWG26)	OUT2	A5
Brown (AWG26)	BKRLS	B2

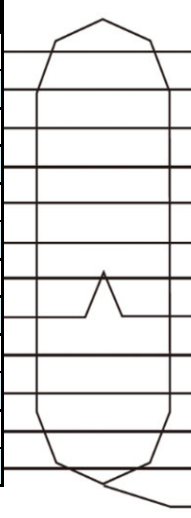

Pin No.	Signal name	Color
2	0V	Black (AWG18)
1	24V (MP)	Red (AWG18)
12	24V (CP)	Light blue (AWG22)
7	OUT0	Orange (AWG26)
8	OUT1	Yellow (AWG26)
9	OUT2	Green (AWG26)
6	SD+	Yellow green (AWG26)
10	SD-	Light gray (AWG26)
3	IN0	Blue (AWG26)
4	IN1	Purple (AWG26)
5	IN2	Gray (AWG26)
11	BKRLS	Brown (AWG26)
13	FG	Green (AWG26)

- The cable length (L) is available from 1m to 10m. Specify the length in increments of 1m.
- Sample model number : Cable length **3**m → **CB-REC2-PWBIO**030**-RB**

1.3.4 Connecting the EC to the Power & I/O Cable

Connect the power & I/O cable.

Have the convex on the connector facing down, insert the connector till it makes a “click” noise.

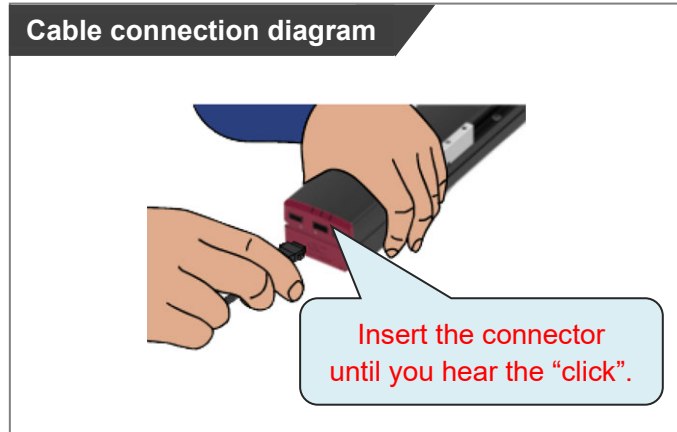

Caution

- The connector must be inserted in a given direction.
Align the arrow marks on the connectors and insert until it clicks into place.
 - Take appropriate care to prevent unused wiring in the loose wire end on the cable from shorting out other wires by protecting them with insulation tape.
-

1.4 Way of Wiring

Reference

- For wiring of power supply and brake release etc., refer to [ELECTRICITY Section Instruction Manual (ME3816)] provided separately.

1.4.1 PLC Wiring (for connect to PIO control / connector)

For I/O between the PLC and signals, the signal wiring must be connected to the connector terminal block.

Connect the 1) to 7) wiring to the connector terminal block while referring to the connection diagram.

- 1) Connect the "B3" connector terminal and the "Backward" output terminal.
- 2) Connect the "B4" connector terminal and the "Forward" output terminal.
- 3) Connect the "B6" connector terminal and the "Alarm clear" output terminal.
- 4) Connect the "A3" connector terminal and the "Backward complete" input terminal.
- 5) Connect the "A4" connector terminal and the "Forward complete" input terminal.
- 6) Connect the "A5" connector terminal and the " Middle point complete" input terminal.
- 7) Connect the "A6" connector terminal and the "Alarm" input terminal.

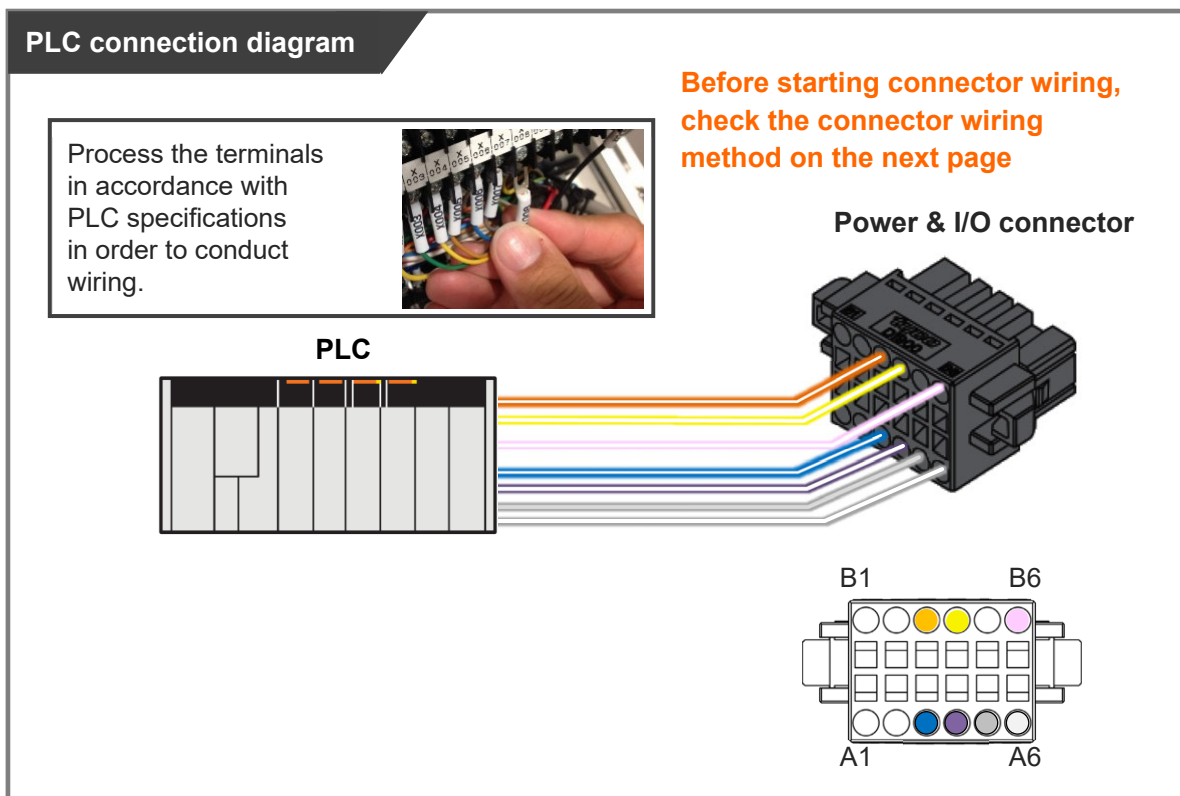

Connector wiring method

◆ Preparation

- Precision screwdriver

Recommended precision screwdriver

Item	Specification
(1) Shaft diameter	1.6±0.03mm
(2) Blade thickness	0.2±0.1mm
(3) Tip angle length	4.2±0.2mm

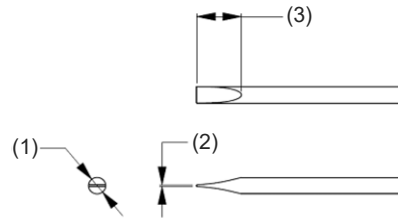

- Wiring

Compatible wire diameter: KIV0.75mm² (AWG18)

◆ How to Conduct Wiring

- 1) Peel the sheath for 7mm and twist the core wires lightly.
- 2) Insert a precision screwdriver fully into the tool insertion slot. Press the spring within the connector down.
- 3) Insert the core wire.
- 4) Pull out the precision screwdriver. Confirm that the cable is not pulled out.

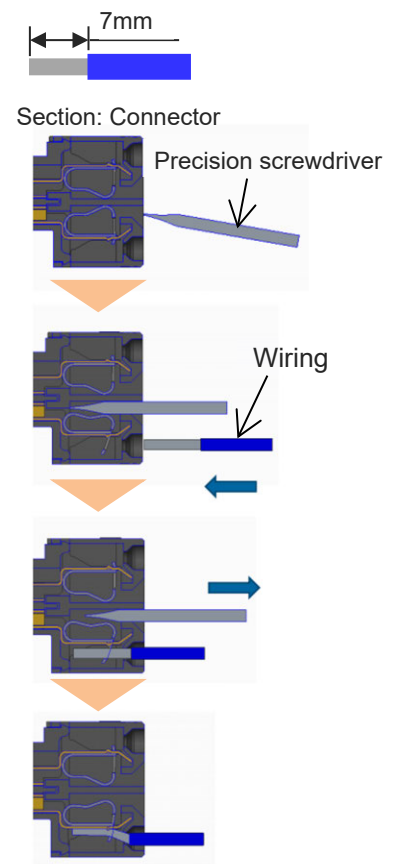

Caution

- Take care not to twist the core wire too far. This will reduce the retention force, causing the wire to fall out of the connector and possibly causing insufficient current or short circuit.
- Do not insert the precision screwdriver violently into the connector, or twist it hard. This may damage the connector housing and internal spring
- If an electric wire thinner than the applicable diameter or wiring longer than 10m is used, insufficient current may trigger an alarm and the performance of the ELECYLINDER may be degraded.

[3-point positioning]

Pin No.	Connector nameplate name	Signal abbreviation	Compatible wire diameter	Function overview
B3	Backward	ST0	KIV0.20mm ² (AWG24)	Backward command
B4	Forward	ST1		Forward command
B5	General input	-		-
B6	Alarm clear	RES		Alarm clear
A3	Backward complete	LS0/PE0		Backward complete / pressing complete
A4	Forward complete	LS1/PE1		Forward complete / pressing complete
A5	General output	LS2		Middle point complete
A6	Alarm	*ALM		Alarm detection (b-contact)

* Input B3 (ST0) and B4 (St1) simultaneously and middle point drive can be made.

1.4.2 PLC Wiring (for connect to PIO control / cables)

For I/O between the PLC and signals, the signal wiring must be connected to the connector terminal block.

Connect the 1) to 7) wiring to the PLC terminal block while referring to the connection diagram.

- 1) Connect the "orange" cable wire and the "Backward" output terminal.
- 2) Connect the "yellow" cable wire and the "Forward" output terminal.
- 3) Connect the "pink" cable wire and the "Alarm clear" output terminal.
- 4) Connect the "blue" cable wire and the "Backward complete" input terminal.
- 5) Connect the "purple" cable wire and the "Forward complete" input terminal.
- 6) Connect the "gray" cable wire and the "Middle point complete" input terminal.
- 7) Connect the "white" cable wire and the "Alarm" input terminal.

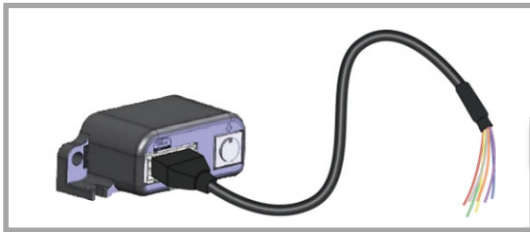

**ELECYLINDER / Interface box,
Power & I/O cable**

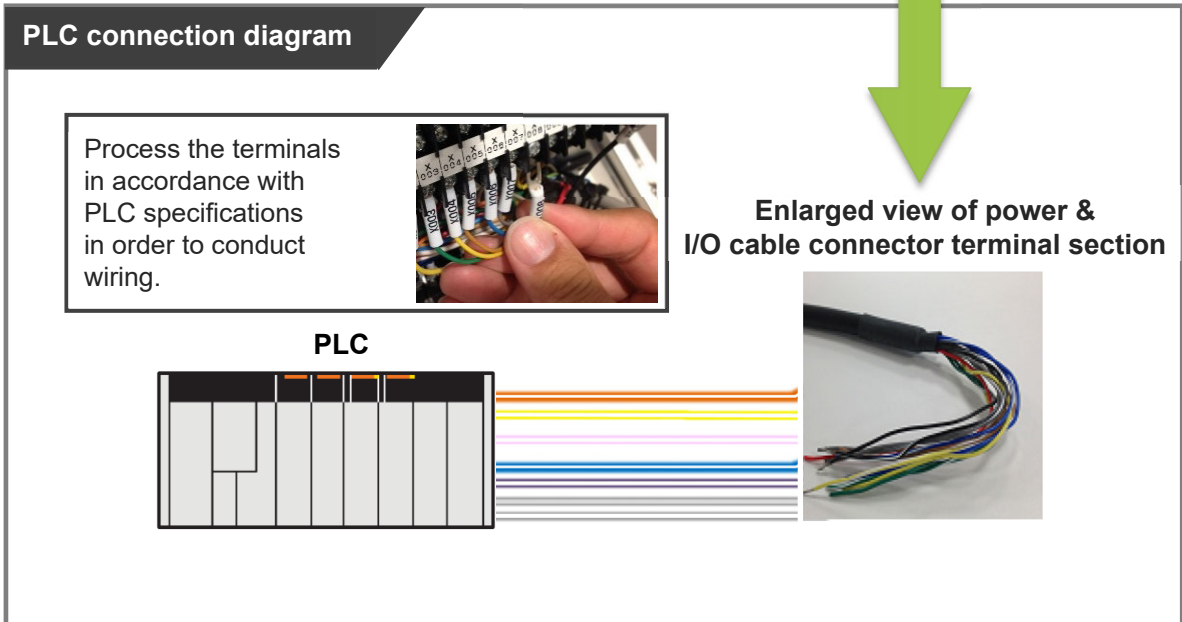

1.4.3 EC Connection Unit Wiring

Refer to [ELECYLINDER Electricity Section Instruction Manual (ME3816)

3.6 EC Connection Unit Wiring] provided separately.

1.5 Teaching Tool

The following teaching tools should be used for setup and operation of ELECYLINDER.
For basic connection and operation, refer to each instruction manual.

◆ Touch Panel Teaching Pendant



TB-03 (Wireless / wired)



TB-02 (Wired)

Refer to [ELECYLINDER Applicable Teaching Pendant TB-03 (Wireless: ME0375 / Wired: ME0376)] or [ELECYLINDER Applicable Teaching Pendant TB-02 (ME0355)] for how to use them.

◆ IA-OS (PC Software)



IA-OS

Install to PC

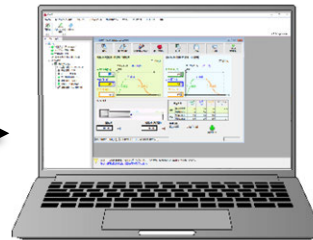

Refer to [IA-OS Fast Step Guide (ME0391)] for how to install
Refer to the [help window in IA-OS] for how to use

◆ Digital Speed Controller / Digital Speed Controller Teaching / Remote Digital Speed Controller



EC-equipped Digital Speed Controller
EC-D□□



Digital Speed Controller Teaching (Wired)
TBD-1



Remote Digital Speed Controller (Wireless)
TBD-1WL

Refer to [Digital Speed Controller / Digital Speed Controller Teaching / Remote Speed Controller (ME3818)] for how to use them.

The versions of each teaching tool to be applicable to the EC 3 position mode specification are as shown below.

Item	Applicable controllers
TB-02/02D (CON System) ^{Note 1}	V5.00 or later
TB-03 Wireless link / Wired link (CON System) ^{Note 1}	V5.00 or later
IA-OS (PC Teaching Software)	V14.00.05.00 or later
EC-equipped Digital Speed Controller	V1.81 or later
Digital Speed Controller Teaching (TBD-1)	V1.81 or later
Remote Digital Speed Controller (TBD-1WL)	V1.51 or later

Note 1 It should be applicable for SEL system software later

1.6 EC Connection Unit

When an ELECYLINDER in the 3 position mode specification is to be connected to R-unit, confirm that the version of RCON-EC-4 (EC connection unit) is that shown in the table below.

Item	Applicable controllers
RCON-EC-4	V0009 or later



Caution

- RCON-EC-4 is applicable for the 3 position mode specification in the version V0009 and later.
Consider to make a request for updating or replacing the device if necessary.

**3 position mode
specification**

Chapter 2

Operation

2.1	Basic Operation	2-1
2.1.1	Operating Method of ELECYLINDER	2-1
2.1.2	Simple Data Setting Window	2-2
2.1.3	DIGITAL SPEED CONTROLLER Window Display	2-7
2.1.4	Operation with a JOG Switch	2-8
2.2	I/O signals	2-9
2.2.1	I/O Signal Assignment	2-9
2.2.2	I/O Signal List	2-11
2.2.3	3-point Positioning "ST0", "ST1" Signals: Movement Command Input (backward/forward/ middle point)	2-12
2.2.4	"LS0", "LS1", "LS2" Signals: Position Detection Output (backward end/forward end/middle point)	2-14
2.3	Operating Method from Master Device	2-16

2.1 Basic Operation

2.1.1 Operating Method of ELECYLINDER

An input signal from a master device to the ELECYLINDER triggers operation of the ELECYLINDER.

The ELECYLINDER status can also be determined when the master device receives signal output from the ELECYLINDER.

Control is just as simple as when using a solenoid valve and air cylinder drive.

Shown below is an image of when PLC is connected to ELECYLINDER as a master device.

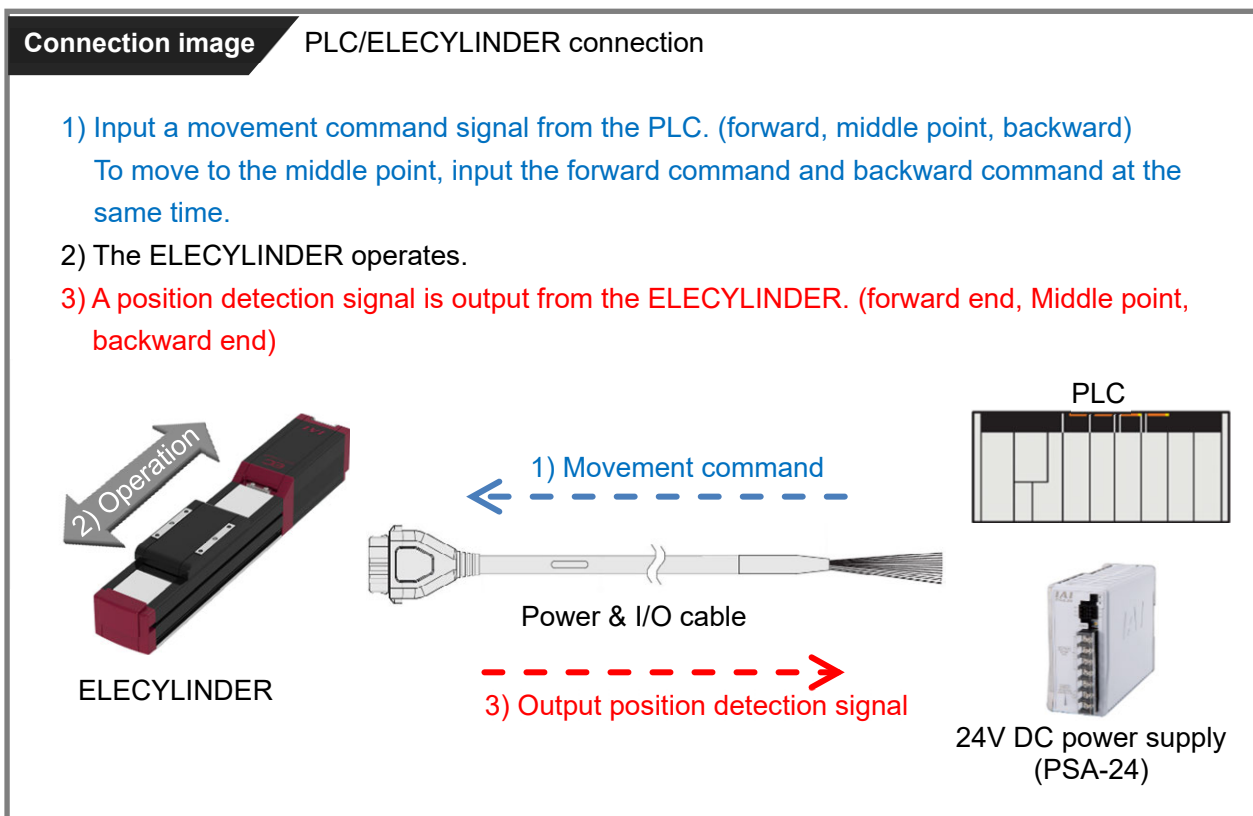

Reference

- Refer also to the separate volume [ELECYLINDER Electricity Section Instruction Manual (ME3816)].

2.1.2 Simple Data Setting Window

[Simple data setting window (For IA-OS)]

By setting Parameter No. 9: Electromagnetic Valve System Select described in 3.1.1 to "3 Positions", the simple data setup window should become as shown below.

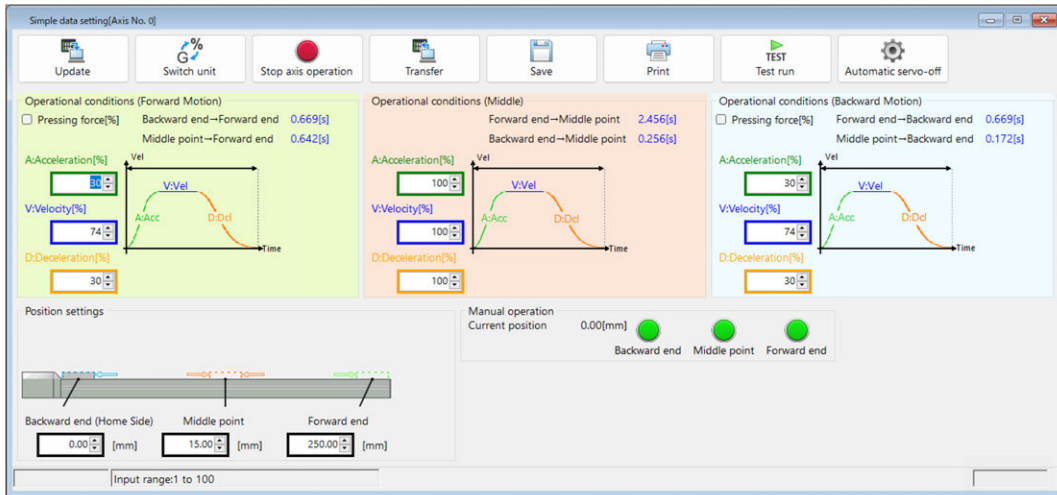

* The display of the Middle point should not appear when the teaching tool version does not satisfy the software version described in [1.5 Teaching Tool].

Here, explains the features in the Simple data setting window in the 2-point positioning setting and in the 3-point positioning setting.

Simple data setting window in 2-Point Positioning Setting

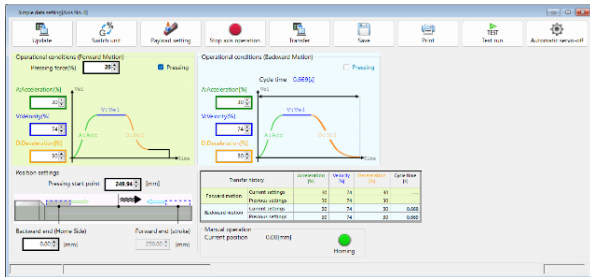

Simple data setting window in 3-Point Positioning Setting

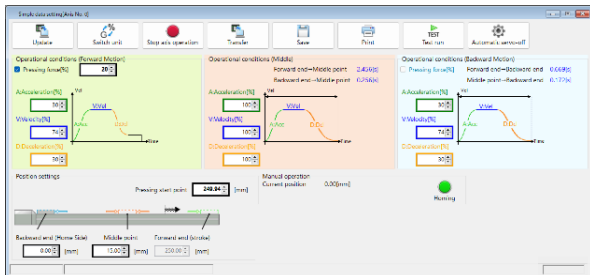

Features of Button in Window (from left)**[Update]**

The position data being displayed should be saved in a file.

[Switch unit]

The units in the operational condition can be switched. (Line below velocity and pressing force is rotary)

Velocity:	[mm/s]	⇔	[%]
	[degree/s]	⇔	[%]
Acceleration/Deceleration:	[G]	⇔	[%]
Pressing force:	[N]	⇔	[%]
	[N/m]	⇔	[%]

[Payload setting] * It is not available to use in the 3-point positioning.

By setting the weight of the payload, the upper limit of the velocity and acceleration/deceleration under the specified condition can be estimated.

[Stop axis operation]

Stop the move operation.

[Transfer]

Transfer edited position data to the controller.

[Save]

Save edited data to a file.

[Print]

Print the position data.

[Test run]

Trial run can be performed at the set position.

[Automatic servo-off]

The time period from the operation stop till the servo to be turned off can be set up.

- Reference**
- In the rotary specification, the unit of position [mm] should be turned to [degree].
 - The jog switch equipped on RCON-EC should get invalid when the window capable to operate ELECYLINDER or a parameter edit window is open in a teaching tool.



Setting the positioning operation

[Positioning operation]

Click on a condition that you would like to adjust to set it up.

- 2-point positioning [Operational conditions (Forward motion: Backward end → Forward end) (Backward Motion: Forward end → Backward end)]
- 3-point positioning [Operational conditions (Forward motion: Backward end / Middle → Forward end) (Forward end / Backward end → Middle point) (Backward Motion: Forward end / Middle → Backward end)]

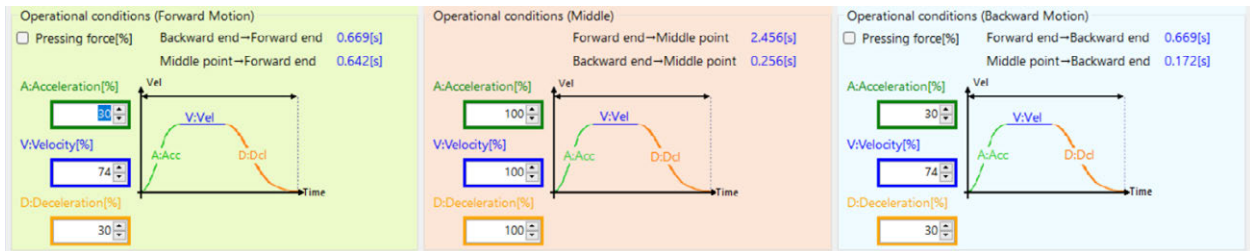

Setting item	Unit	Explanation
A: Acceleration	% or G	The acceleration at the start of operation should be set. Set in a value from 0 to 100%. Click "Switch Unit", and the unit should get turned to [G], and the setup can be made down to two decimal places.
V: Velocity	% or mm/s, degree/s	The positioning operation velocity should be set up. Set in a value from 0 to 100%. Click "Switch Unit", and the unit should get turned to [mm/s (degree/s)], and the setup can be made down to two decimal places.
D: Deceleration	% or G	The deceleration at operation stop should be set up. Set in a value from 0 to 100%. Click "Switch Unit", and the unit should get turned to [G], and the setup can be made down to two decimal places.

[Position settings]

The positions of the backward end and the forward end should be set up.

Input the position from the datum point with the coordinate values for positioning.

The unit should be [mm] or [degree], and it can be input down to two decimal places.

2-point positioning

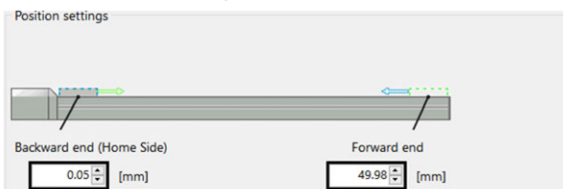

3-point positioning

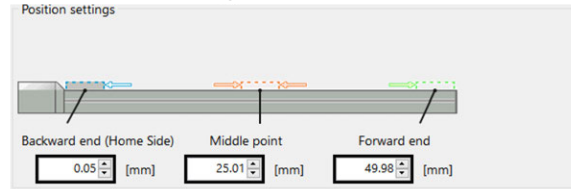

Reference • In the rotary specification, the unit of position [mm] should be turned to [degree].

Setting the Pressing operation

[Position settings]

Put a checkmark (✓) in a checkbox (☐) of the "pressing force" for the way forward or backward. The direction for pressing should differ in the way forward and backward. pressing should not be done at the middle point.

- 2-point positioning [Operational conditions (Forward motion: Backward end → Forward end) (Backward Motion: Forward end → Backward end)]
- 3-point positioning [Operational conditions (Forward motion: Backward end / Middle → Forward end) (Forward end / Backward end → Middle point) (Backward Motion: Forward end / Middle → Backward end)]

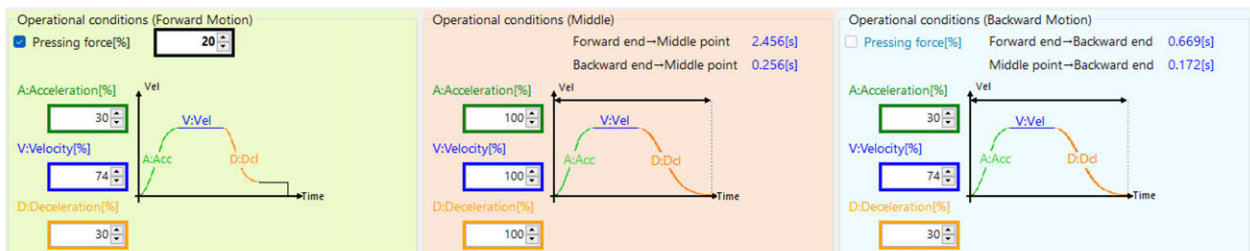

Setting item	Unit	Explanation
A: Acceleration	% or G	The acceleration at the start of operation should be set. Set in a value from 0 to 100%. Click "Switch Unit", and the unit should get turned to [G], and the setup can be made down to two decimal places.
V: Velocity	% or mm/s, degree/s	The operation velocity from the start point of the operation (forward end or backward end) to the start point for pressing should be set up. Set in a value from 0 to 100%. Click "Switch Unit", and the unit should get turned to [mm/s (degree/s)], and the setup can be made down to two decimal places.
D: Deceleration	% or G	The operation deceleration from the start point of the operation to the start point for pressing should be set up. Set in a value from 0 to 100%. Click "Switch Unit", and the unit should get turned to [G], and the setup can be made down to two decimal places.

[Position settings]

Set up the operation start point and the pressing start point. Input the position from the datum point with the coordinate values for positioning. The unit should be [mm] or [degree], and it can be input down to two decimal places.

2-point positioning

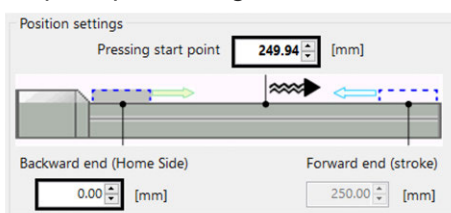

3-point positioning

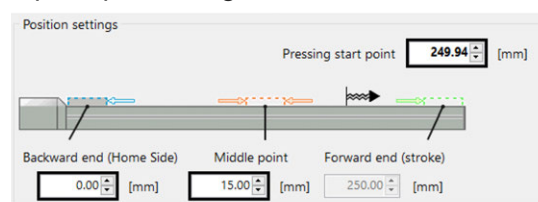

- Reference**
- In the rotary specification, the unit of position [mm] should be turned to [degree].
 - Pressing operation cannot be performed in the belt driven type (EC-B6 and B7). Attempt to put a checkmark to pressing, and an alarm should be displayed and the checkmark will not be input.

Manual operation button

The home return button should be displayed when the home return operation is not yet completed, and operation buttons to each position when the home return operation is already completed.

[Manual operation]

Operation should be made while "Backward end" "Middle point" or "Forward end" is being clicked.

2-point positioning

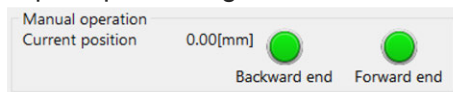

3-point positioning

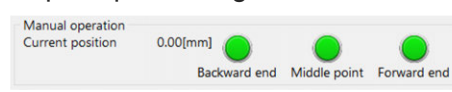

[Homing]

The home return operation should be performed.

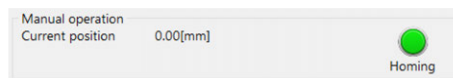

2.1.3 DIGITAL SPEED CONTROLLER Window Display

Here, explains the different points in the ELECYLINDER 3 position mode specification (hereinafter called as 3-Point Specification) compared with the digital speed controller (digital speed controller teaching and remote speed controller).

Shown below are the window displays different in 3-Point Specification and 2-Point Specification.

There is no difference in operation due to specifications.

For the details of operation, refer to [DIGITAL SPEED CONTROLLER Instruction manual (ME3818)].

	2-point specification	3-point specification
AVD Set. window	<pre> AVD Set. % A V D F 30 70 100 B 80 100 50 </pre>	<pre> AVD Set. AVD Set. % A V D % A V D F 30 70 100 M 70 100 30 B 80 100 50 </pre>
Simple Set window	<pre> SimplSet Level Velocity FORWARD 10 BACKWARD 8 </pre>	<pre> SimplSet SimplSet Level Velocity Level Velocity FORWARD 10 MIDDLE 5 BACKWARD 8 </pre>
Test run window	<pre> Test run ▲ Bwd Fwd ▼ Current Pos. 9999.99 mm </pre>	<pre> Test run ▲ Bwd ▲ Mid ▼ Fwd Current Pos. 9999.99 mm </pre>
Test run window (Rotary Type)	<pre> Test run ◀ CCW CW ▶ Current Pos. 0.00deg </pre>	<pre> Test run ◀ CCW ▲ Mid ▶ CW Current Pos. 0.00deg </pre>
Pos. Set. window	<pre> Pos. Set. ◀ BEnd FEnd ▶ FEnd Pos. 9999.99 mm </pre> <p>BEnd for Backward End FEnd for Forward End Pressing for Pressing Start Point</p>	<pre> Pos. Set. ◀ BEnd ▲ Mid ▶ FEnd FEnd Pos. 9999.99 mm </pre> <p>BEnd for Backward End Mid for Middle Point FEnd for Forward End Pressing for Pressing Start Point</p>
Teach Pos. window	<pre> Teach Pos. ◀ BEnd FEnd ▶ 9999.99 mm ← : Pos. Set. </pre>	<pre> Teach Pos. ◀ BEnd ▲ Mid ▶ FEnd 9999.99 mm ← : Pos. Set. </pre>

2.1.4 Operation with a JOG Switch

As the jog switch equipped on the EC connection unit (RCON-EC-4) to be used for R-unit is purposed for the jog operation, it does not possess the middle point positioning feature.

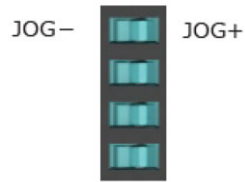

Operation	Operation of EC
JOG+	Movement to Forward End
JOG-	Movement to Backward End
Center	Stop

2.2 I/O Signals

2.2.1 I/O Signal Assignment

[1] For PIO control

The ELECYLINDER I/O signals in the 3 position mode specification are as shown below.

【I/O signal assignment details】

		Symbol	Signal name
Input	IN0	ST0	Backward
	IN1	ST1	Forward
	IN2	-	-
	IN3	RES	Alarm clear
Output	OUT0	LS0/PE0	Backward complete or Pressing complete
	OUT1	LS1/PE1	Forward complete or Pressing complete
	OUT2	LS2	Middle point complete
	OUT3	*ALM	Alarm (b-contact)

* The operation commands to the middle point should be made by inputting ST0 (backward) and ST1 (forward) simultaneously.

Check in [2.2.2 I/O signal list] for details of each signal.

Also, refer to [2.3 Operating Method from Master Device] for operation sequences.

[2] For RCON-EC Connection

Below shows the I/O signal assignment for one unit of the EC connection unit (RCON-EC-4).
Assignment for four units of ELECYLINDER is allocated in one unit of the EC connection unit.

[Input Signal]

b15	b14	b13	b12	b11	b10	b9	b8	b7	b6	b5	b4	b3	b2	b1	b0
IN3	IN2	IN1	IN0	IN3	IN2	IN1	IN0	IN3	IN2	IN1	IN0	IN3	IN2	IN1	IN0
Control signal (4th axis)				Control signal (3rd axis)				Control signal (2nd axis)				Control signal (1st axis)			

[Output Signal]

b15	b14	b13	b12	b11	b10	b9	b8	b7	b6	b5	b4	b3	b2	b1	b0
OUT3	OUT2	OUT1	OUT0	OUT3	OUT2	OUT1	OUT0	OUT3	OUT2	OUT1	OUT0	OUT3	OUT2	OUT1	OUT0
Status signal (4th axis)				Status signal (3rd axis)				Status signal (2nd axis)				Status signal (1st axis)			

* The details of the input and output signal assignment to each axis are as shown below.

Control signal	IN0	ST0	Backward
	IN1	ST1	Forward
	IN2	-	Not for use
	IN3	RES	Alarm clear
Status signal	OUT0	LS0/PE0	Backward complete or Pressing complete
	OUT1	LS1/PE1	Forward complete or Pressing complete
	OUT2	LS2	Middle point complete
	OUT3	*ALM	Alarm (b-contact)

2.2.2 I/O Signal List

ELECYLINDER I/O signals are as follows.

[3-point positioning]

Category	Signal name	Signal abbreviation	Function overview
Input	Backward	ST0	Turning ON sends it backward. Turning OFF midway through operation will cause a gradual stop.
			Turning ON when home return is not complete triggers home return operation. Turning OFF midway through operation will cause a gradual stop.
	Middle point	ST0+ST1	Turn both on simultaneously and operation should be made to the middle point.
	Forward	ST1	Turning ON sends it forward. Turning OFF midway through operation will cause a gradual stop.
			Turning ON when home return is not complete triggers home return operation. Turning OFF midway through operation will cause a gradual stop.
	Alarm clear	RES	Turning ON resets the alarm.
Brake release	BKRLS	Inputting 24V DC releases the brake.	
Output	Backward complete or Pressing complete	LS0 or PE0	ON when entering the backward end detection range. ON when pressing operation is complete.
	Forward complete or Pressing complete	LS1 or PE1	ON when entering the forward end detection range. ON when pressing operation is complete.
	Middle point complete	LS2	ON when entering the middle point detection range.
	Alarm (b-contact)	*ALM	ON in normal conditions. OFF when an alarm occurs.



Caution

- When home return is complete and when it is not, the "ST0" signal and "ST1" signal have different functions.
- The pressing operation cannot be made in the middle point operation.

2.2.3 3-point Positioning "ST0", "ST1" Signals: Movement Command Input (backward/forward/middle point)

The ST signal function automatically switches depending on whether the unit has completed home return or not.

Signal name	Signal abbreviation	Function overview by status	
		Home return: Not complete	Home return: Complete
Backward	ST0	Backward after home return operation	Backward
Forward	ST1	Forward after home return operation	Forward
Middle point	ST0 + ST1	Middle point after home return operation	Middle point

[Home return status: Not complete]

- When the "ST0" signal is turned ON, home return operation begins.
The actuator should move to the backward end after the home return operation completes.
- When the "ST1" signal is turned ON, as with the "ST0" signal, home return operation begins.
The actuator should move to the forward end after the home return operation completes.
- Turn on "ST0" Signal and "ST1" Signal at the same time, and the home-return operation should start.
The actuator should move to the middle point end after the home return operation completes.
- Turning the ST signal OFF midway through home return operation will cause a gradual stop.

[Home return status: complete]

- When the ST signal is turned ON, the moving part moves Backward or Forward.
- While the ST signal is ON, operation will continue until the Backward end, Forward end, Middle point is reached.
- Turning the ST signal OFF midway through operation will cause a gradual stop.

For details, refer to [2.3 Operating Method from Master Device].



Caution

- When accuracy in stop at the middle point is required, have the both signals kept on. Even a few ms of mismatch in the timing to turn off the forward / backward signals after reaching the middle point, misalignment from the middle point (movement to either forward or backward direction) could occur.
- When a stop is being made without LS Signal or PE Signal being ON, it is possible that the ELECYLINDER is stopped out of the position detection range of the backward end, forward end or middle point, or it is stopped after miss-pressing during the pressing operation at the backward end or forward end.
We recommend first inputting the "ST0" signal and then performing the following actions after returning to the backward end.
- When the encoder type is the incremental type, the condition after the power is rebooted should be in the home return incomplete. Also, the battery-less absolute specification is necessary to perform the home return operation (absolute reset) when parameters are changed in "Home return Direction Change", "Home Position Adjustment" as the condition of home return should get to incomplete.
For details, refer to [ELECYLINDER Electricity Section Instruction Manual (ME3816) 6.4 Parameter function descriptions].

2.2.4 "LS0", "LS1", "LS2" Signals: Position Detection Output (backward end/forward end/middle point)

- The LS signals perform the same operation as an air cylinder automatic switch.
- The LS signals turn ON when the current ELECYLINDER position is within the detection range configured at the backward and forward ends.
- They turn ON when within the detection range regardless of whether the servo is ON or OFF if home return has completed.

The backward end and forward end set values' relationship to "LS0", "LS1" and "LS2" signals ON is as follows.

In this example, the LS signal detection range is $\pm 0.50\text{mm}$.

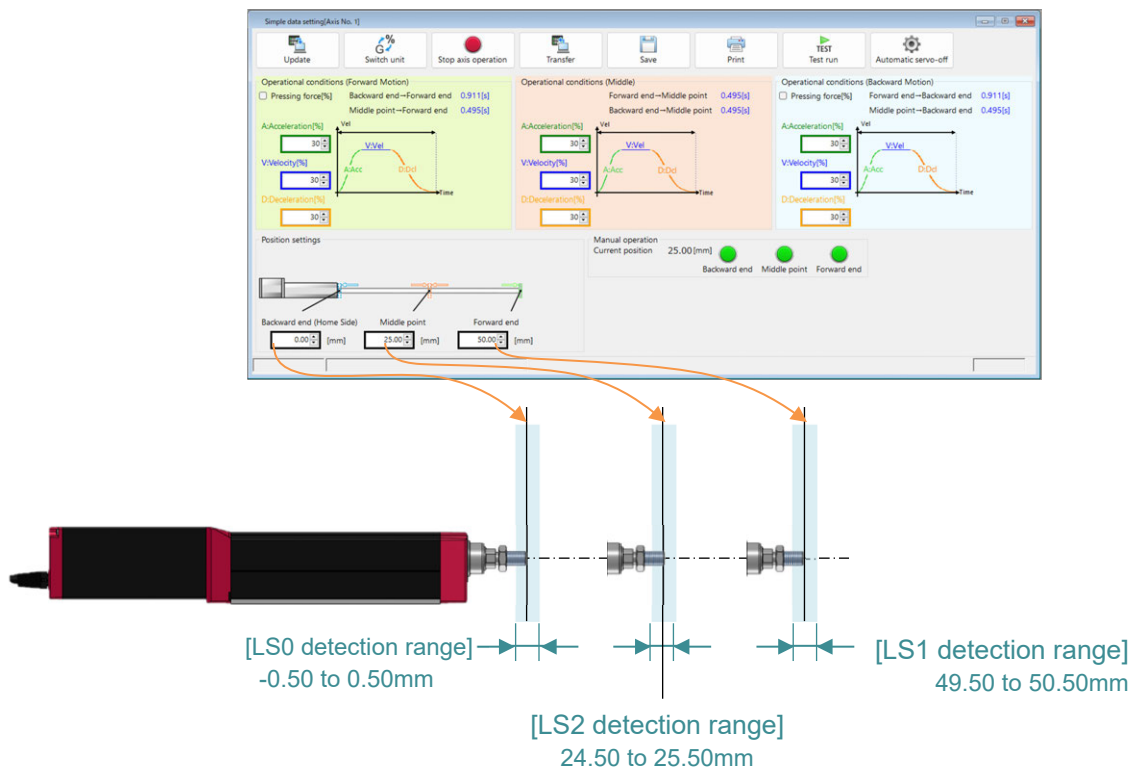

To adjust the LS signal detection range, open the "Parameters window".

Parameter No.2 "AutSwitch "LS" Signl Detctn Rng Adjst" can be used to make adjustments.

Parameter		Axis No. 00
1. Operation Range Adjustment	Descrptn	50.00 mm
2. AutSwitch "LS" Signl Detctn Rng Adjst	Descrptn	0.50 mm
3. HOME Direction Change	Descrptn	<input type="radio"/> Opposite <input checked="" type="radio"/> Default
4. HOME Position Adjustment	Descrptn	2.00 mm
5. Smooth accel/decel Setting	Descrptn	<input checked="" type="radio"/> Disable <input type="radio"/> Enable
6. Current control setting while stop	Descrptn	<input checked="" type="radio"/> Disable <input type="radio"/> Enable
7. Wireless Function Setting	Descrptn	<input type="radio"/> Disable <input checked="" type="radio"/> Enable
8. Reserve		

By touching Descrptn (Description) button, the description of the parameter will be displayed. ↓ Nx pg

**Caution**

- If the pulse motor mounted type is in the battery-less absolute specification and also TMD2 type is used, "LS0", "LS1" and "LS2" will not turn ON even if the position is in the detection range when the power is turned off while the motor power supply is cut off. Turn the servo ON after the power is supplied, and "LS0", "LS1" and "LS2" signals should turn ON.
-

2.3 Operating Method from Master Device

Turning the "ST0" signal ON when home return is not complete will first trigger home return operation. After a momentary stop at the home position, it will then move to the backward end. As well, when the "ST1" signal is turned ON, the unit will move to the forward end after home return operation. When "ST0" Signal and "ST1" Signal are turned on at the same time, the actuator should move to the middle point after the home-return operation is performed.

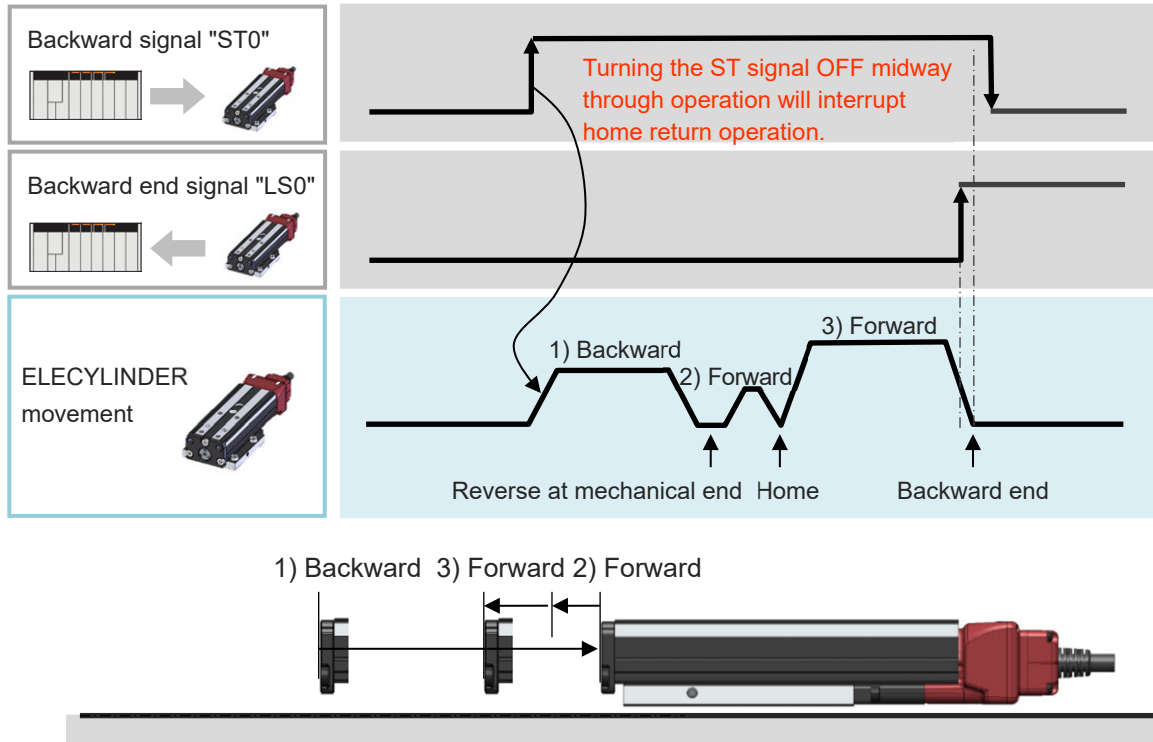

Operation Behavior While Home return Operation (When "ST0" Signal is Used)

- 1) When the "ST0" signal is turned ON, backward motion begins towards the mechanical end. The movement speed is 20mm/s.
- 2) Once the mechanical end is struck, the direction will be reversed and forward motion will begin. The unit will move forward until the home position, then stop.
- 3) After that, it will continuously move forward until the backward end, where it stops as operation is complete.



Caution

- In the home reverse specification (model: NM), home return operation is in the reverse direction.

This shows the PLC timing chart for operating the ELECYLINDER.

[1] Move to Forward End / Backward End



[Basic timing chart]

Output ELECYLINDER → output signals to PLC

Input PLC → input signals to ELECYLINDER

Category	Signal abbreviation	Timing chart	Remarks
1	Power	Power ON LED status: OFF → Orange ON → Green ON	24V DC power supply is turned ON.
2	Output	* ALM	Turns ON if no alarm has been triggered.
3	Input	ST0 $\Delta t1$	When the "ST0" signal is turned ON, home return operation begins.
4	Output	LS0 $\Delta t2$	Home return operation is complete and the unit moves to the backward end.
5	Input	ST1 $\Delta t2$	Moves to the forward end.
6	Output	LS1	Moved to the forward end.
7	Input	ST0 $\Delta t2$	Moves to the backward end.
8	Output	LS0	Moved to the backward end.
9	After this, "5" to "8" repeat.		

$\Delta t1$: Wait approximately 0.5 seconds from when the "**ALM" signal turns ON before inputting the first command.

$\Delta t2$: The time taken for the ELECYLINDER actually to reach the forward or backward end after the LS signal turns ON. Consider $\Delta t2$ when giving instructions for the next operation from the PLC to the ELECYLINDER.

$\Delta t2$ becomes longer for larger detection ranges.

$\Delta t2$ also changes with the size of the transported load and acceleration/deceleration speeds.

2.3 Operating Method from Master Device

Turning the ST signal OFF midway through operation will cause a gradual stop.
For example, be careful of the following point with a large LS signal detection range.

If the sequence is set to turn the ST signal OFF immediately after the LS signal turns ON, the moving parts may not have reached the forward/backward end.

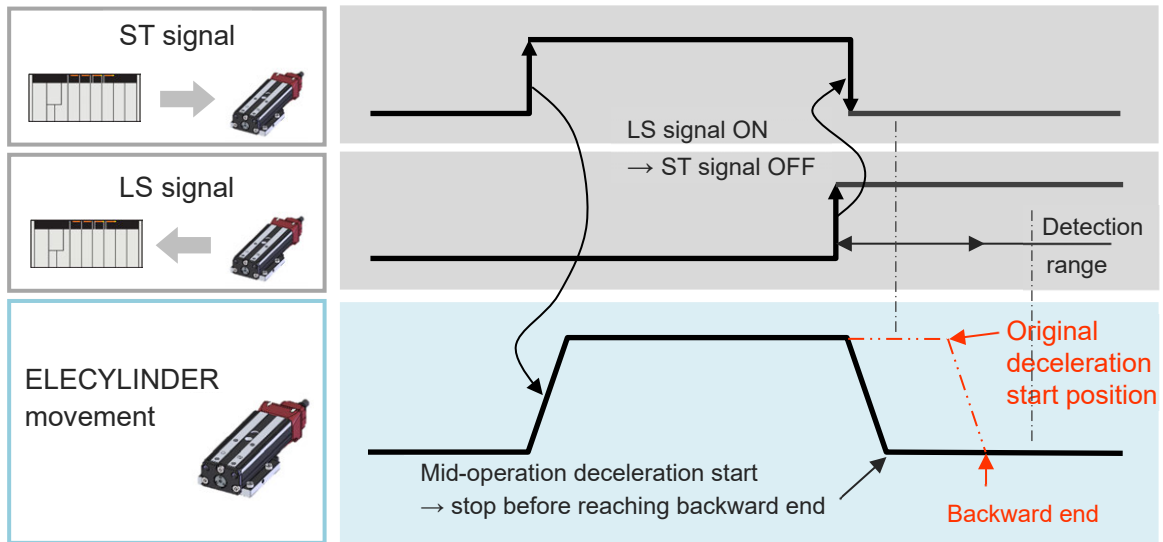

Caution

- Turning the "ST" signal ON again after the gradual stop causes the ELECYLINDER to begin operation again.
- Within the detection range, the LS signal turns ON even if the ELECYLINDER is mid-operation.
- When used with standard specifications (2-point positioning: double solenoid mode or single solenoid mode), make sure that "ST0" and "ST1" do not turn ON simultaneously. "ST0" Signal should be prioritized when both are turned ON at the same time, and "ST0" Signal should get input.

[2] Move to Middle point

The timing chart to drive ELECYLINDER to the middle point should be as shown below.



Category	Signal abbreviation	Timing chart	Remarks
1	Input ST0		Turn "ST0" and "ST1" signal ON simultaneously and operation should be made to the middle point.
	Input ST1		
2	Output LS2		Moved to the middle point.
3	Input ST1		Moves to the backward end.
4	Output LS1		Moved to the backward end.

Δt_2 : The time taken for the ELECYLINDER actually to reach the middle point and forward end / backward end after the LS signal turns ON. Consider Δt_2 when giving instructions for the next operation from the PLC to the ELECYLINDER.

Δt_2 becomes longer for larger detection ranges.

Δt_2 also changes with the size of the transported load and acceleration/deceleration speeds.

- * After "ST0" and "ST1" is turned ON simultaneously, during operation to the middle point or after the middle point operation is completed (LS2 Output status), keep "ST1" turned ON and turn "ST0" OFF, and operation to the forward end should be made. Also, if "ST0" Signal is kept ON and "ST1" gets turned OFF, operation to the backward end should be made.
- *1 If the timings to turn "ST0" OFF and to turn "ST1" OFF do not match, after the middle point operation is completed (LS2 Output status), there may be a possibility that operation to the forward or backward starts.
- *2 When accuracy in stop at the middle point is required, have ST0 and ST1 kept on until the next movement command.



Caution

- About the pressing operation:
The pressing operation cannot be set in the middle point operation.

**3 position mode
specification**

Chapter 3

Parameters

3.1	Parameters	3-1
3.1.1	Parameter No.9: Electromagnetic Valve System Select.....	3-1
3.1.2	Parameter No.10: LED Lighting System Automatic Switch Setting	3-1

3.1 Parameters

Reference

- For details of the parameters, refer to the separate volume [ELECYLINDER Electricity Section Instruction Manual (ME3816) Chapter 6 Parameters].

3.1.1 Parameter No.9: Electromagnetic Valve System Select

No.	Category	Name	Unit	Input range	Default setting at shipping
9	A	Electromagnetic valve system select	–	Double, Single, 3 position	Double

3.1.2 Parameter No.10: LED Lighting System Automatic Switch Setting

No.	Category	Name	Unit	Input range	Default setting at shipping
10	A	LED lighting system automatic switch setting	–	Disabled, Enabled	Disabled

- The Ultra Mini ELECYLINDER is capable of adding a display of such as forward end / backward end / middle point just like an automatic switch on an air-cylinder to the LED.
- Set it to "Disable (default setting on delivery from factory)" and the ordinary status LED display (servo-ON/OFF, emergency stop, alarms, wireless status, etc.) should be performed.
- Set it to "Enable" and "Forward End / Backward End", "Pressing Complete" and "Miss-Pressing Detected" should be shown in addition to the ordinary status LED displays.

The LED display is described on the following page.

[The Ultra Mini ELECYLINDER LED Display]

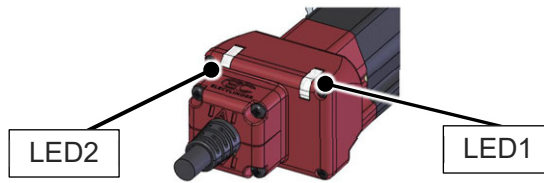

Set it to "Disable"

LED2	LED1	Color	Operation status
×	×	-	Power OFF Servo OFF
●	●	Orange	In Initializing at Startup
★	×	Green	In Wireless Connection
★	×	Red	Wireless Hardware Error
×	●	Red	Alarm
×			In Emergency Stop
×	★↔★	Green, Red	Minor malfunction alarm
×	●	Green	Servo ON
×	★	Green	In process of automatic servo OFF

Set it to "Enabled"

LED2	LED1	Color	Operation status
In addition to LED displays in "Disable", following displays are to be added.			
●	×	Orange	Backward End [LS0]
×	●	Orange	Forward End [LS1]
●	●	Orange	Middle Point [LS2]
★	×	Orange	Pressing Complete in Backward End Direction [PE0]
×	★	Orange	Pressing Complete in Forward End Direction [PE1]
●	×	Orange	Miss-Pressing Detected in Backward End Direction
×	●	Orange	Miss-Pressing Detected in Forward End Direction

● : Light ON, ★ : Blinking, × : Light OFF



Caution

- This feature is available only for the Ultra Mini ELECYLINDER (Type: SL3□/GDS3L/GDB3□/T3□). This feature is not available for use for other models of ELECYLINDER.
- When Connecting Interface Box:
The LED display on the interface box should be the one in "Disable" regardless of the parameter setting.
- Settings of "Enable" should not be reflected while in wireless connection.

Revision History

Revision date	Revised content
2025.03	First Edition
2025.04	1B Edition <ul style="list-style-type: none"> • 1.3.2 Power Supply / I/O Connector correction made to model codes • 1.5 TB-02/03 applicable version information added • Correction made, sentences revised in explanations
2025.05	1C Edition <ul style="list-style-type: none"> • 1.2 2-Circuit Power Supply Specification NPN/PNP Type A3 signal name corrected • 2.1.1 Operating Method of ELECYLINDER correction made to explanation • 2.2.3, 2.3 Description added about middle point movement • 2.3 Operation from Host correction made to note in timing chart with PLC • Change made to reference
2025.07	1D Edition <ul style="list-style-type: none"> • Precautions for Handling When accuracy in middle point stop is required added • 2.2.3 When accuracy in middle point stop is required note added • 2.3 [2] Move to Middle Point change made to timing chart • Terms and format integrated



IAI Corporation

Head Office: 1210 Ihara Shimizu-KU Shizuoka City Shizuoka 424-0114, Japan
TEL +81-54-364-5105 FAX +81-54-364-2589
website: www.iai-robot.co.jp/

IAI America, Inc.

Head Office: 2690 W. 237th Street, Torrance, CA 90505
TEL +1-310-891-6015 FAX +1-310-891-0815
Chicago Office: 110 East State Parkway, Schaumburg, IL 60173
TEL +1-847-908-1400 FAX +1-847-908-1399
Atlanta Office: 1220 Kennestone Circle, Suite 108, Marietta, GA 30066
TEL +1-678-354-9470 FAX +1-678-354-9471
website: www.intelligentactuator.com

Technical Support available in Europe

IAI Industrieroboter GmbH

Ober der Röth 4, D-65824 Schwalbach am Taunus, Germany
TEL +49(0)6196-88950 FAX +49(0)6196-889524
website: www.iai-automation.com

Technical Support available in Great Britain



Duttons Way, Shadsworth Business Park, Blackburn, Lancashire, BB1 2QR, United Kingdom
TEL +44(0)1254-685900
website: www.lcautomation.com

IAI (Shanghai) Co., Ltd.

SHANGHAI JIAHUA BUSINESS CENTER A8-303, 808, Hongqiao Rd. Shanghai 200030, China
TEL+86-21-6448-4753 FAX +86-21-6448-3992
website: www.iai-robot.com

IAI Robot (Thailand) Co., Ltd.

825 PhairojKijja Tower 7th Floor, Debaratana RD., Bangna-Nuea, Bangna, Bangkok 10260, Thailand
TEL +66-2-361-4458 FAX +66-2-361-4456
website: www.iai-robot.co.th