



GRS Actuator Solenoid Gripper

First Step Guide Second Edition

Thank you for purchasing our product. Make sure to read the Safety Guide and detailed Instruction Manual as well as this First Step Guide to ensure correct use. This Instruction Manual is original.

Warning: Read the instruction manual carefully and follow the instruction manual when handling this equipment. Please download the user's manual from our website. You can download it free of charge. User registration is required for first time users. URL: www.iai-robot.co.jp/data_dl/CAD_MANUAL/ Keep a printout of the introduction manual near the equipment in which this product is installed so that it can be checked at all times, or display it on your computer, tablet terminal, etc. so that you can check it immediately. If you need a bound copy of the instruction manual, order it from the nearest sales office listed in the First Step Guide or at the end of the instruction manual. It will be provided for a fee.

- Using or copying all or part of this Instruction Manual without permission is prohibited.
- The company names, names of products and trademarks of each company shown in the sentences are registered trademarks.

Product Check

This product is comprised of the following parts if it is of standard configuration. If you find any fault in the contained model or any missing parts, contact us or our distributor.

1. Parts (The option is excluded.)

No.	Part Name	Model	Quantity	Remarks
1	Solenoid Gripper	Refer to "How to Read the Model Nameplate" and "How to Read the Model Number".	1	
Accessories				
2	Driver Box	Refer to "How to Read the Model Nameplate".	1	
3	Solenoid Driver Cable (Note1)	CB-GRS-PCS□□□	1	□□□ shows the cable length 1m to 15m
4	Safety Guide	M0194	1	

Note 1 Please refer to the wiring layout for the enclosed solenoid driver cable.

2. How to read the model plate

2.1 Solenoid Gripper Main Body

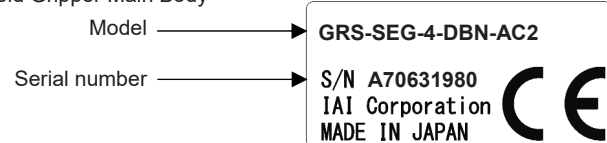

2.2 Driver Box

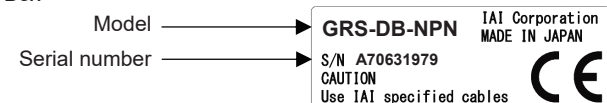

3. How to read the model No.

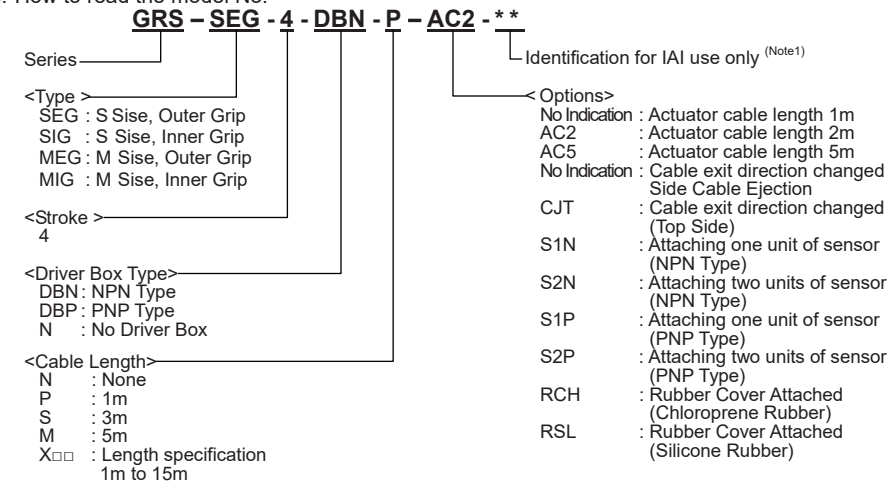

Note 1 Identification for IAI use only: It may be displayed for IAI use. It is not a code to show the model type.

[Refer to the catalog or Instruction Manual for specification details.]

Precautions in Handling

- Handling the Packed Unit**
 - Do not damage or drop. The package is not applied with any special treatment that enables it to resist an impact caused by a drop or crash.
 - Keep the unit in a horizontal orientation when placing it on the ground or transporting. Follow the instruction if there is any for the packaging condition.
 - Do not step or sit on the package.
 - Do not put any load that may cause a deformation or breakage of the package.
- Handling the Actuator After Unpacking**
 - Do not carry the actuator by its motor unit or its cable or attempt to move it by pulling the cable.
 - Hold the body when transporting the actuator main body.
 - Do not hit or drop the actuator during transportation.
 - Do not attempt to force any part of the actuator. Do not apply excess force especially on the finger attachment.

Environments for Installation, Storage and Preservation

1. Installation Environment

Usage is possible in environments of pollution degree 3 or equivalent.

The actuator should be installed in a location other than those specified below. Also provide sufficient work space required for maintenance inspection.

- Where the actuator receives radiant heat from strong heat sources such as heat treatment furnaces
- Where the ambient temperature exceeds the range of 0 to 40 °C
- Where the temperature changes rapidly and condensation occurs
- Where relative humidity smaller than 20% or larger than 85%RH
- Where the actuator receives direct sunlight
- Where the actuator is exposed to corrosive or combustible gases
- Where the ambient air contains a large amount of powder dust, salt or iron (at level exceeding what is normally expected in an assembly plant)
- Where the actuator is subject to splashed water, oil (including oil mist or cutting fluid) or chemical solutions
- Where the actuator receives impact or vibration
- Place with an altitude of 2,000m or more

If the actuator is used in any of the following locations, provide sufficient shielding measures:

- Where noise generates due to static electricity, etc.
- Where the actuator is subject to a strong electric or magnetic field
- Where the actuator is subject to ultraviolet ray or radiation

2. Storage • Preservation Environment

- The storage and preservation environment should comply with the same standards as those for the installation environment. In particular, when the machine is to be stored for a long time, pay close attention to environmental conditions so that no dew condensation forms.
- Unless specially specified, moisture absorbency protection is not included in the package when the machine is delivered. In the case that the machine is to be stored and preserved in an environment where dew condensation is anticipated, take the condensation preventive measures from outside of the entire package, or directly after opening the package.
- For storage and preservation temperature, the machine withstands temperatures up to 60 °C for a short time, but in the case of the storage and preservation period of 1 month or more, control the temperature to 50 °C or less.
- Storage and preservation should be performed in the horizontal condition. In the case it is stored in the packaged condition, follow the posture instruction if any displayed on the package.

Names of the Parts

1. Solenoid Gripper Main Body

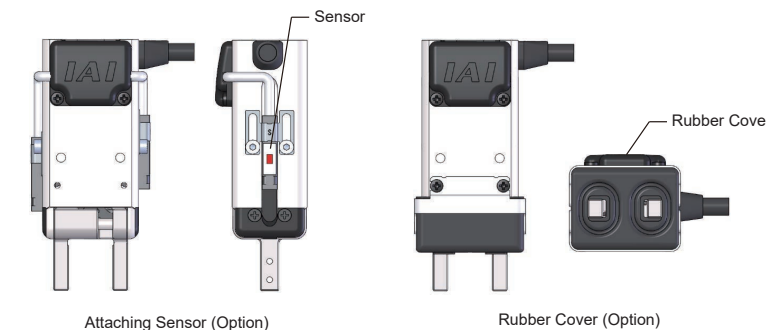
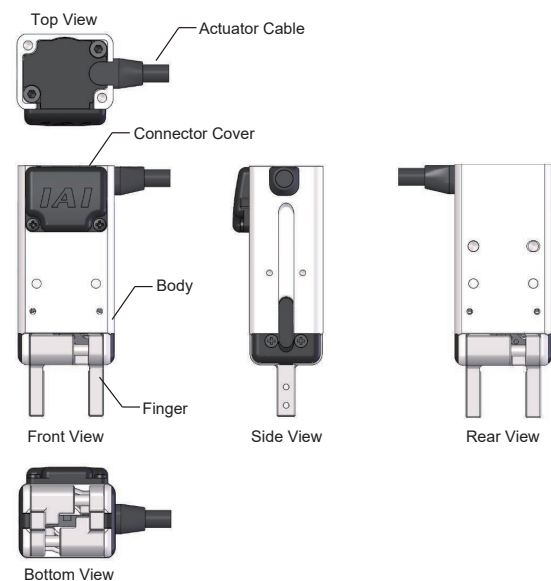

2. Driver Box

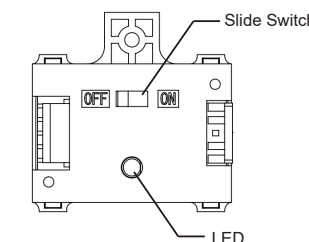

- Set this slide switch to "ON" side and the fingers on the solenoid gripper for the outer gripping type should be compulsorily open. For the inner gripping type, it should be compulsorily close. While the switch is on, the LED lamp should be on. Turn the slide switch OFF when in use.

[For the details of dimensions and outlines, refer to the catalog or Instruction Manual.]

Attachment

Refer to the Instruction Manual for the attachments of the actuator and loads.

[Precautions for Attachments]

No.	Item	Precautions
1	Attachment	<ul style="list-style-type: none"> Temperature goes up when in releasing operation as the current flows. The temperature increase could vary depending on the frequency of open and close operation, condition of unit installation, attachment material and so on. In case there is a concern of temperature influence on a workpiece, use a material which possesses high heat conduction performance such as aluminum for attachment of the unit. Use a material which possesses low heat conduction performance such as plastic for finger attachment. Have enough space for the maintenance work.
2	Bolt to be used	<ul style="list-style-type: none"> For the bolts to be used, a high-tensile bolt complying with ISO-10.9 or more is recommended. If using the tapped holes, use screws with the thread length dimension being less than the effective depth of the holes. For the actuator mounting, use a bolt with the dimension of its effective mating length to the tapped hole is as stated below. If tapped hole on steel → thread length same as nominal diameter. If tapped hole on aluminum → thread length 1.8 times longer than nominal diameter.
3	Tightening Torque	<ul style="list-style-type: none"> Please follow the specification values stated in the Instruction Manual for the tightening torque. Failure to do so may cause an operation problem.
4	Allowable Moment	<ul style="list-style-type: none"> Make sure that the allowable moment is at or below the maximum allowable moment described in Instruction Manual. Applying load exceeding the maximum allowable moment may cause a drop in the product life. If it is extreme, flaking may occur.

Wiring

The following shows the system configuration.

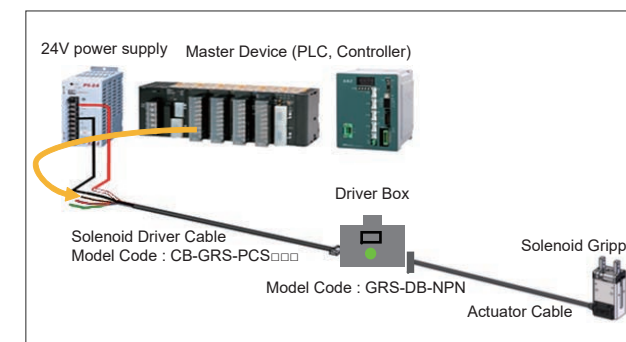

Supply 24V DC in the circuit shown below. The outer grip type opens fingers once Open (ON) signal gets input. And it closes fingers once Close (OFF) signal gets input. The inner grip type works in the other way.

[NPN Type]

Item	Specifications
Input voltage	DC24V±10%
Input current	2mA
Leakage current	Max. 0.25mA
Operation Voltage	ON voltage : Max. 6.0V
	OFF voltage : Input voltage Min. -3.0V
Isolation type	Non-isolated

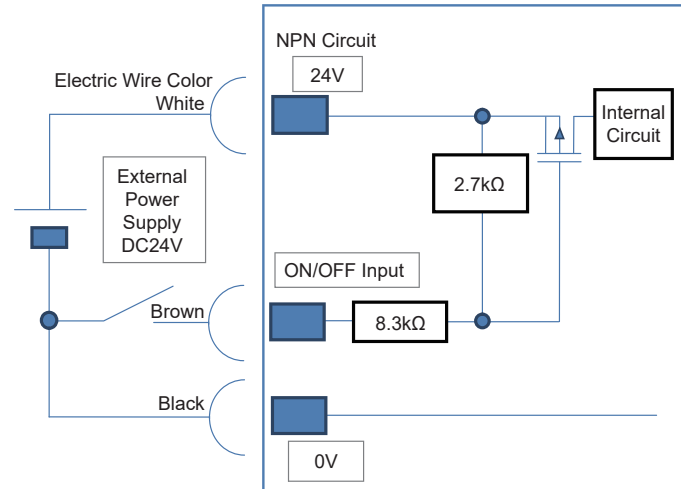

[PNP Type]

Item	Specifications
Input voltage	DC24V±10%
Input current	2mA
Leakage current	Max. 0.25mA
Operation Voltage	ON voltage : Min. 18.0V
	OFF voltage : Input voltage Max. 3.0V
Isolation type	Non-isolated

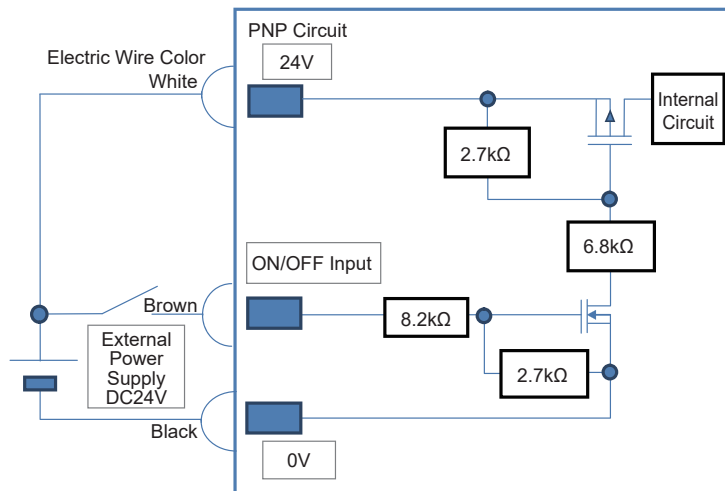

For the driver box, only the dedicated driver box manufactured by our company can be used. Using an undedicated driver box may cause an accident such as burnout, combustion or heat generation.

Use the dedicated cable enclosed in the package when connecting the actuator and the driver box.

[Prohibited Items in the Cable Processing]

- Do not pull or bend forcibly the cable so as to give any extra load or tension to the cable.
- Do not process the cable to extend or shortening by means of cutting out, combination or connecting with another cable.

- Do not let the cable flex at a single point.

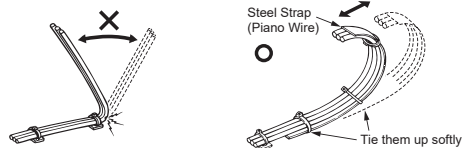

- Do not let the cable bend, kink or twist.

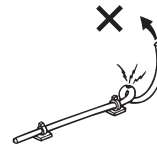

- Do not pull the cable with a strong force.

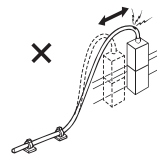

- Do not let the cable receive a turning force at a single point.

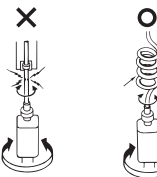

- Do not pinch, drop a heavy object onto or cut the cable.

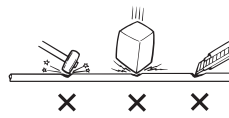

- When fixing the cable, provide a moderate slack and do not tension it too tight.

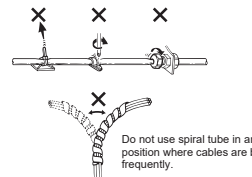

- Separate the I/O line, communication line and power line from each other. Do not store in the same duct.

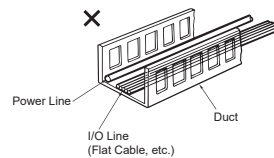

Follow the instructions below when using a cable track.

- If there is an indication to the cable for the space factor in a cable track, refer to the wiring instruction given by the supplier when storing the cable in the cable track.
- Avoid the cables to get twined or twisted in the cable track, and also to have the cables move freely and do not tie them up. (Arrange the wiring so the cables are not to be pulled when bent.) Do not pile up cables. It may cause faster abrasion of the sheaths or cable breakage.

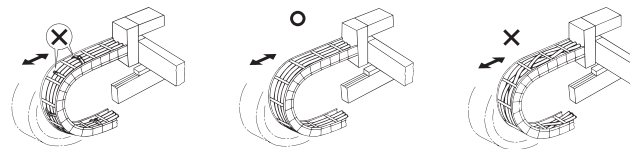

⚠ Note:

- When the cable is connected or disconnected, make sure to turn off the power. When the cable is connected or disconnected with the controller power turned ON, it might cause a malfunction of the actuator and result in a serious injury or damage to the machinery.
- When the connector connection is not correct, it would be dangerous because of a malfunction of the actuator. Make sure to confirm that the driver box is connected correctly.

IAI
Quality and Innovation

IAI Corporation

Head Office: 1210 Iharacho Shimizu-KU Shizuoka City Shizuoka 424-0114, Japan
TEL +81-54-364-5105 FAX +81-54-364-2589
website: www.iai-robot.co.jp/

IAI America, Inc.

Head Office: 2690 W. 237th Street, Torrance, CA 90505
TEL +1-310-891-6015 FAX +1-310-891-0815
Chicago Office: 110 East State Parkway, Schaumburg, IL 60173
TEL +1-847-908-1400 FAX +1-847-908-1399
Atlanta Office: 1220 Kennestone Circle, Suite 108, Marietta, GA 30066
TEL +1-678-354-9470 FAX +1-678-354-9471
website: www.intelligentactuator.com

Technical Support available in Europe

IAI Industrieroboter GmbH

Ober der Röth 4, D-65824 Schwalbach am Taunus, Germany
TEL +49(0)6196-88950 FAX +49(0)6196-889524
website: www.iai-automation.com

Technical Support available in Great Britain

LC Automation
control & safety

Duttons Way, Shadsworth Business Park, Blackburn, Lancashire, BB1 2QR, United Kingdom
TEL +44(0)1254-685900
website: www.lcautomation.com

IAI (Shanghai) Co., Ltd.

SHANGHAI JIAHUA BUSINESS CENTER A8-303, 808, Hongqiao Rd. Shanghai 200030, China
TEL +86-21-6448-4753 FAX +86-21-6448-3992
website: www.iai-robot.com

IAI Robot (Thailand) Co., Ltd.

825 PhairojKijja Tower 7th Floor, Debaratana RD., Bangna-Nuea, Bangna, Bangkok 10260, Thailand
TEL +66-2-361-4458 FAX +66-2-361-4456
website: www.iai-robot.co.th

Manual No.: ME3789-2B