



IS Series Actuator

First Step Guide Fourth Edition

IS · ISP · ISA · ISPA/ ISWA · ISPWA/ISD · ISDA · ISPDA/ ISDCR · ISPDCR · ISDACR · ISPDACR

Thank you for purchasing our product.
Make sure to read the Safety Guide and detailed Instruction Manual as well as this First Step Guide to ensure correct use.
This Instruction Manual is original.

Warning : Read the instruction manual carefully and follow the instruction manual when handling this equipment.
Please download the user's manual from our website.
You can download it free of charge. User registration is required for first time users.
URL: www.iai-robot.co.jp/data_dl/CAD_MANUAL/
Keep a printout of the introduction manual near the equipment in which this product is installed so that it can be checked at all times, or display it on your computer, tablet terminal, etc. so that you can check it immediately.
If you need a bound copy of the instruction manual, order it from the nearest sales office listed in the First Step Guide or at the end of the instruction manual. It will be provided for a fee.

- Using or copying all or part of this Instruction Manual without permission is prohibited.
- The company names, names of products and trademarks of each company shown in the sentences are registered trademarks.

Product Check

This product is comprised of the following parts if it is of standard configuration.
If you find any fault in the contained model or any missing parts, contact us or our distributor.

1. Parts (The option is excluded.)

No.	Part Name	Remarks
1	Main Body	"How to read the model plate", "How to read the model No."
Accessories		
2	Home Position Marking Sticker	
3	Washer for High-Tensile Bolt	IS/ISP/ISP/ISPA Enclosed in: Medium size M□M, M□MX Large size L□M, L□MX, LXUWX Super-large size WXM, WXXM
4	Safety Guide	M0194

2. How to read the model plate

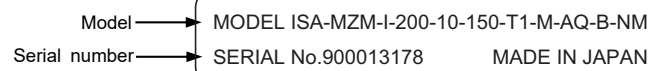

3. How to read the model No.

3.1 IS/ISP/ISA/ISPA

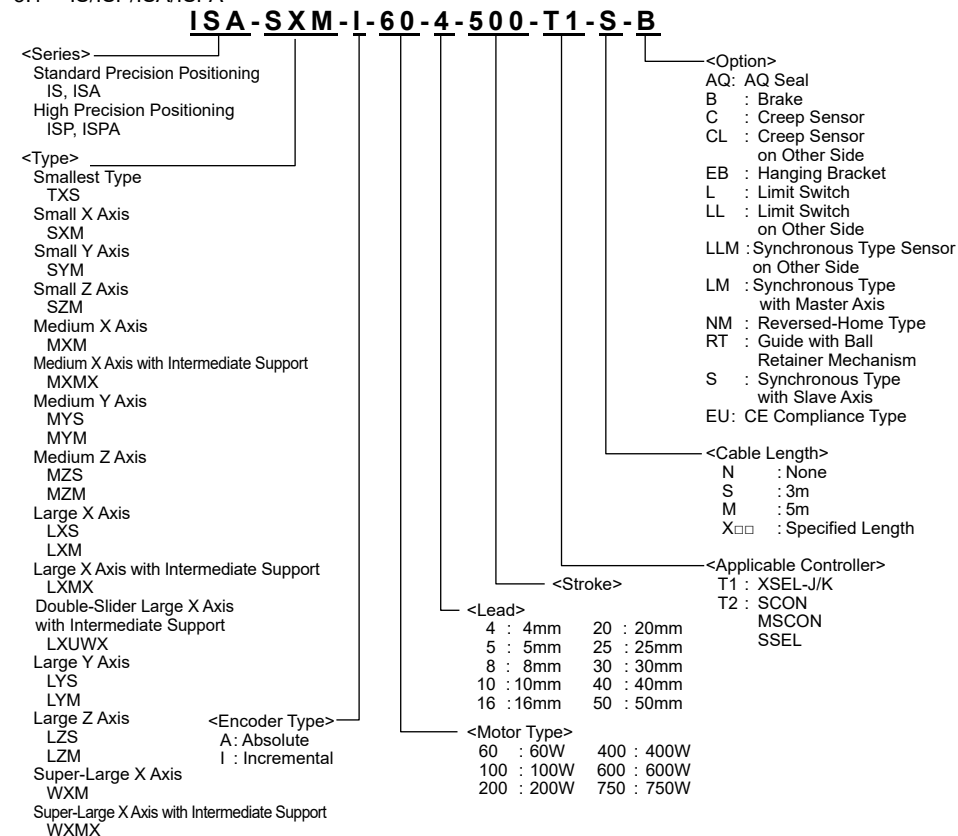

3.2 Splash-Proof Type ISWA/ISPWA

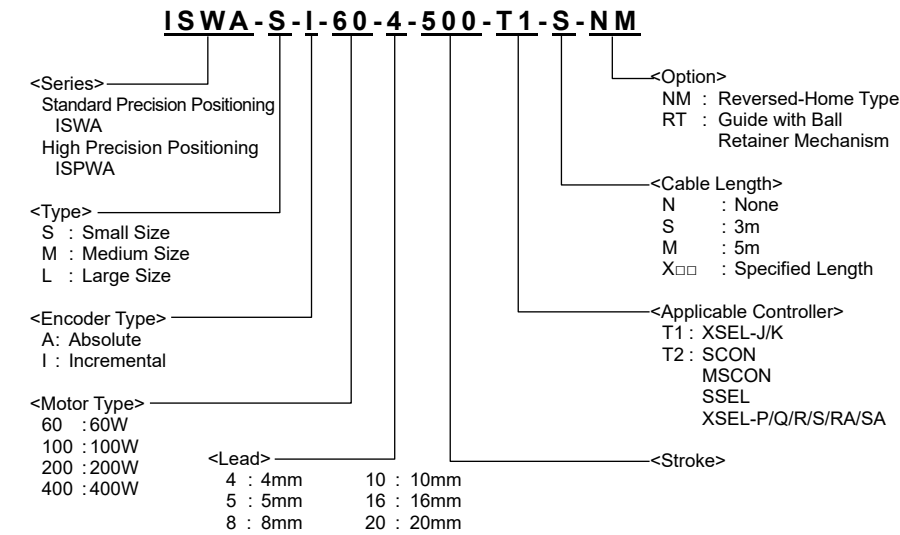

3.3 Stainless Steel Protection ISD/ISDA/ISPA

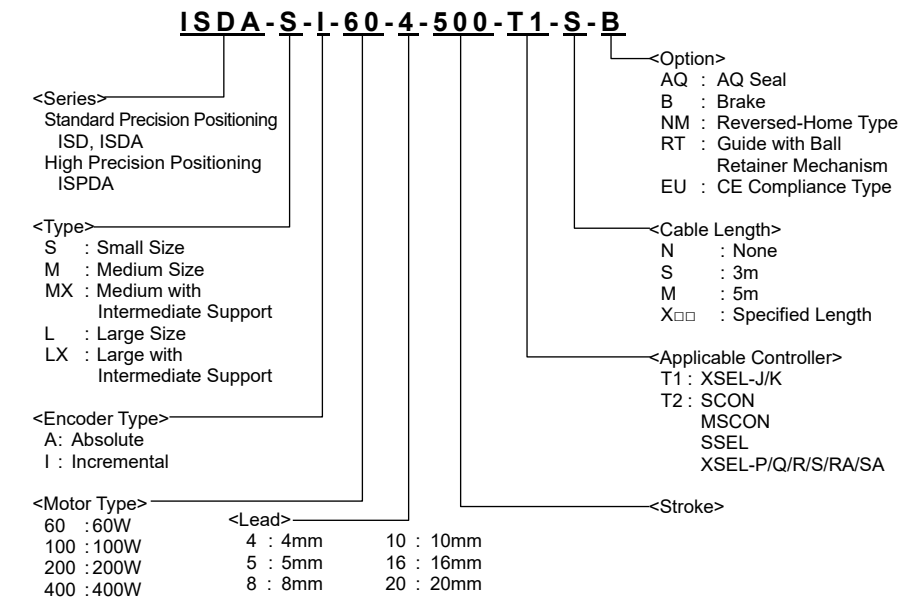

3.4 Stainless Steel Protection, Clean Room Type ISDCR/ISPDCR/ISDACR/ISPDACR

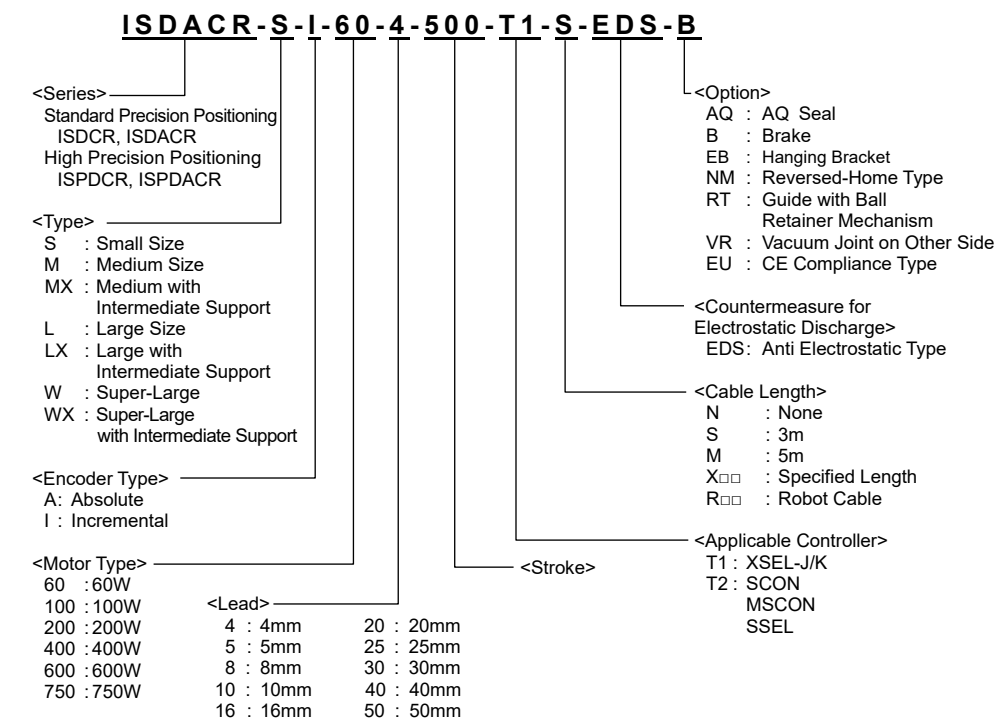

Precautions in Handling

1. Handling of Robot

1.1 Handling of the Packed Product

- Unless otherwise specified, the actuator is shipped with each axis packaged separately.
- Do not damage or drop. The package is not supplied with any special treatment that enables it to resist an impact caused by a drop or crash.
 - Transport a heavy package with at least more than two operators. Consider an appropriate method for transportation.
 - If the shipping box is to be left standing, it should be in a horizontal position. Follow the instruction if there is any for the packaging condition.
 - Do not get on the package.
 - Do not put any load that may cause a deformation or breakage of the package.

1.2 Handling of Robot without Package

- Do not carry the actuator by holding the cable, or do not move it by pulling the cable.
- Hold the body base when transporting the actuator.
- When carrying the actuator, exercise caution not to bump it against nearby objects or structures.
- Do not give any excessive force to any of the sections in the actuator.

2. Handling of Multi-Axes Type

2.1 Handling of the Packed Product

Multi-axes type will be delivered in a package with an outer case fixed to a wooden base. Sliders are fixed so they would not accidentally move while in transportation. The tip of the actuator is also fixed to avoid it swinging by external vibration.

- Do not damage or drop. The package is not supplied with any special treatment that enables it to resist an impact caused by a drop or crash.
- Transport a heavy package with at least more than two operators. Consider an appropriate method for transportation.
- When suspending the package using ropes, pass the ropes from underneath the reinforcement frames at the bottom of the base. When lifting with a forklift, also place the forks underneath the base.
- Do not apply an impact on the package or let it bounce when putting it down.
- Do not get on the package.
- Do not put any load that may cause a deformation or breakage of the package.

2.2 Handling of Robot without Package

- Secure the sliders to prevent sudden movement during transport.
- If any tip of the actuator is overhanging, secure it properly to avoid significant movement due to external vibration.
- If the actuator assembly is transported without the tips being secured, do not apply impact of 0.3G or more.
- In the case that the actuator needs to be carried up with ropes or another method, be sure to use an appropriate cushioning to avoid the robot being deformed or put on an excessive pressure. And also, be sure to keep the robot in a stable and horizontal posture. Utilize the tapped holes on the bottom of the base to attach a tool to suspend the package if necessary.
- Be careful not to apply a load on any of the actuator brackets or covers or on the connector box. Also, avoid the cables being pinched or caused an excessive deformation.

3. Handling of Robot Mounted on Mechanical Equipment (System)

Note the following when the whole mechanical equipment (system) that the actuator is mounted on needs to be transported.

- Secure the sliders to prevent sudden movement during transport.
- If any tip of the actuator is overhanging, secure it properly to avoid significant movement due to external vibration.
- If the actuator assembly is transported without the tips being secured, do not apply impact of 0.3G or more.
- When suspending the mechanical equipment (system) with ropes, avoid applying force to actuator, connector box, etc. Also, avoid the cables being pinched or caused an excessive deformation.

Installation Environment, Storage Environment

1. Installation Environment

An environment that satisfies the following conditions is required during installation.

In general, IS/ISP/ISA/ISPA, Stainless Steel Protection Type ISD/ISDA/ISPA and Clean Room Type ISDCR/ISPDCR/ISDACR/ISPDACR should be used in the environment where an operator can work without equipping any protective gear.

- There should be no direct sunlight.
- Any radiant heat from a large heat source such as a heat treatment furnace should not be directed at the machine main body.
- The ambient temperature should be 0 to 40°C.
- The relative humidity should be 85% or less. There should not be dew condensation. (IS/ISP/ISA/ISPA, Stainless Steel Protection ISD/ISDA/ISPA, Clean Room Type ISDCR/ISPDCR/ISDACR/ISPDACR)
- If air purge is performed, the actuator will have water resistance of the protective structure shown in the table below. (Splash-Proof Type ISWA/ISPWA)
- There should be no corrosive gas or flammable gas.
- There should be no flammable dust or ignitable liquid in the surroundings.
- Oil mist or cutting liquid should not be directed at the machine.
- Chemical liquid should not be splashed on it.
- An impact or vibration should not be transmitted to it.
- There should be no strong electromagnetic waves, ultraviolet rays or radiation.
- The actuator should not be installed where it gets dipped in liquid.
- The working space required for maintenance or inspection should be secured.

2. Storage and Preservation Environment

The storage and preservation environment should comply with the same standards as those for the installation environment. In particular, when the machine is to be stored for a long time, pay close attention to environmental conditions so that no dew condensation forms.

Unless specially specified, moisture absorbency protection is not included in the package when the machine is delivered. In the case that the machine is to be stored in an environment where dew condensation is anticipated, take the condensation preventive measures from outside of the entire package, or directly after opening the package.

For storage temperature, the machine withstands temperatures up to 60°C for a short time, but in the case of the storage period of 1 month or more, control the temperature to 50°C or less.

Storage and preservation should be performed in the horizontal condition.

Names of the Parts

1. IS/ISP/ISA/ISPA

1.1 IS/ISP/ISA/ISPA except ISP-W/ISA-W/ISPA-W

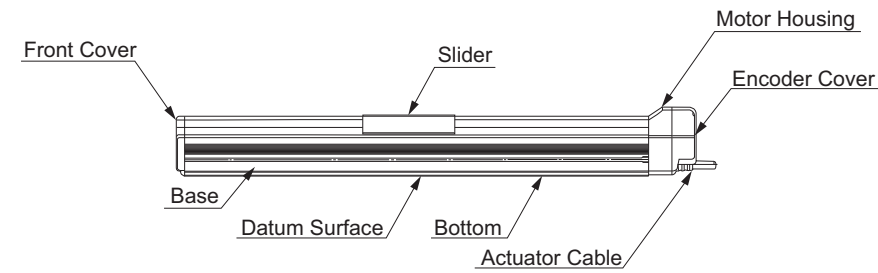
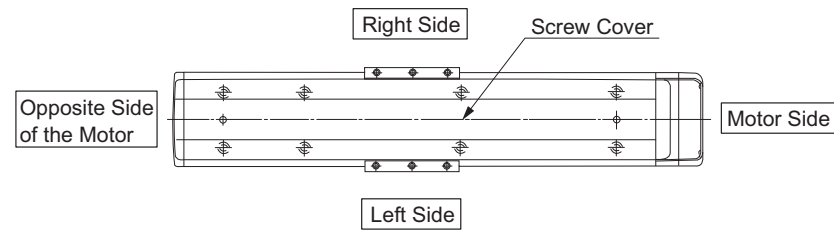

1.2 ISP-W/ISA-W/ISPA-W

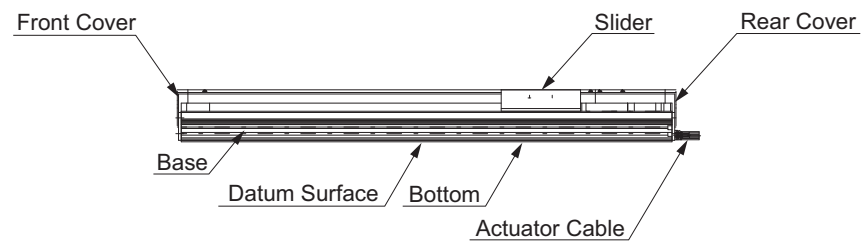
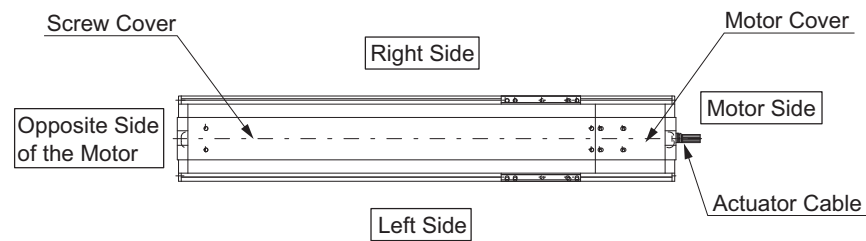

For the details of dimensions and outlines, refer to the catalog or Instruction Manual.

2. Splash-Proof Type ISWA/ISPWA

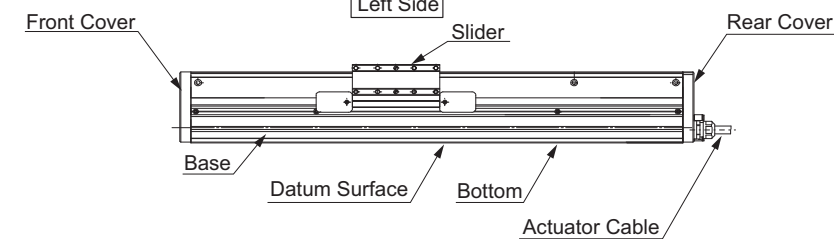
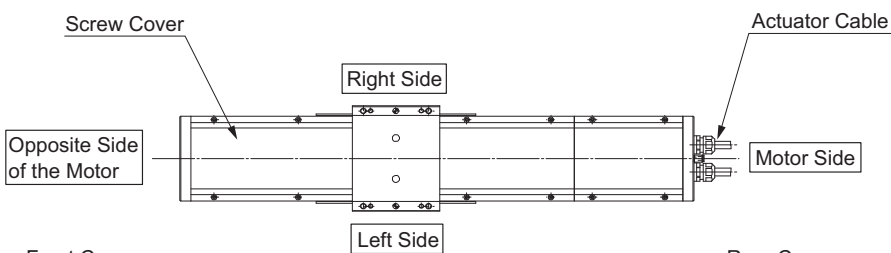

For the details of dimensions and outlines, refer to the catalog or Instruction Manual.

3. Stainless Steel Protection ISD/ISDA/ISPA

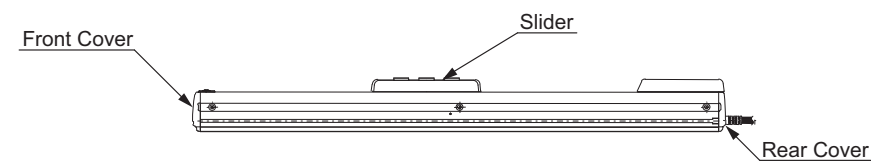
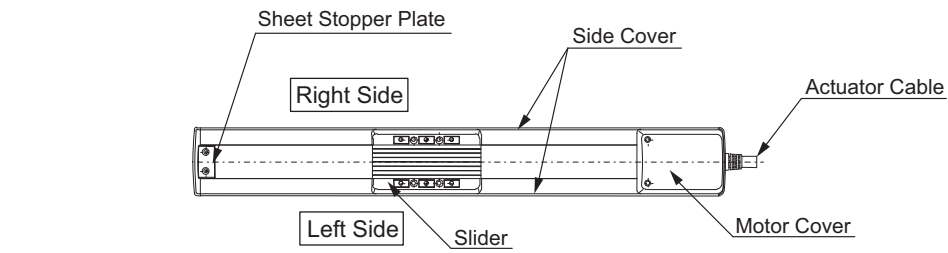

For the details of dimensions and outlines, refer to the catalog or Instruction Manual.

4. Stainless Steel Protection, Clean Room Type ISDCR/ISPDCR/ISDACR/ISPDACR

4.1 ISDCR/ISPDCR/ISDACR/ISPDACR except ISPDACR-W/ISDACR-W/ISPDACR-W

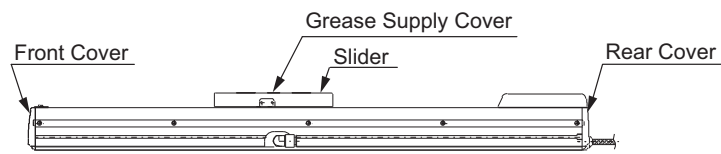
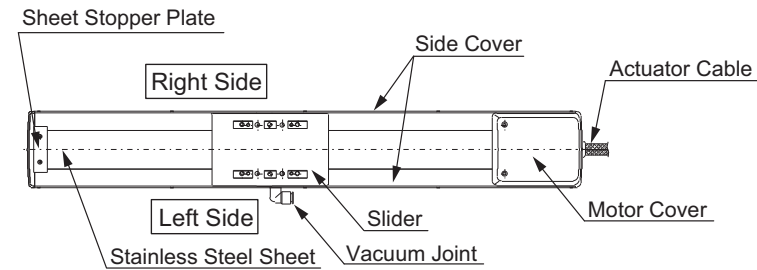

For the details of dimensions and outlines, refer to the catalog or Instruction Manual.

4.2 ISPDACR-W/ISDACR-W/ISPDSCR-W

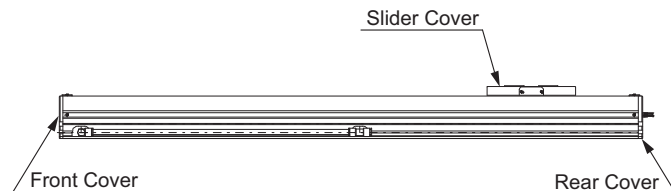
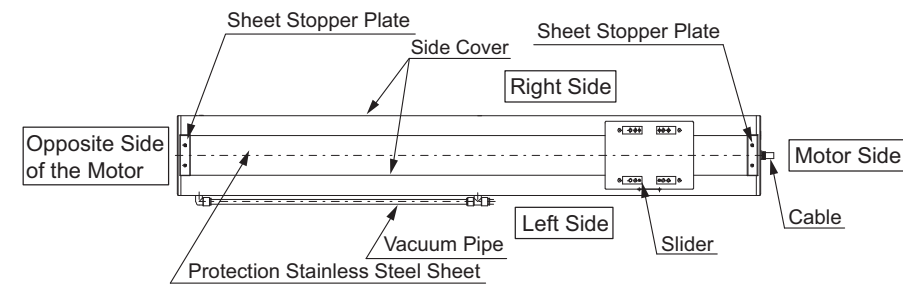

For the details of dimensions and outlines, refer to the catalog or Instruction Manual.

Attachment

Refer to the Instruction Manual for the attachments of the actuator and loads.

[Precautions for Attachments]

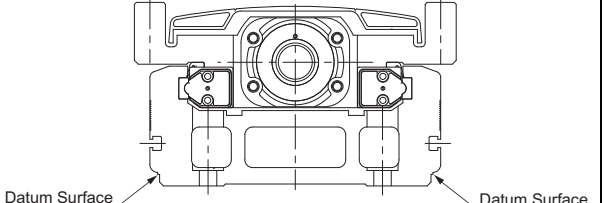
No.	Item	Precautions
1	Installation	<ul style="list-style-type: none"> Installing the slider type actuator with a stroke of 400mm or more to horizontally oriented wall mount or ceiling mount may cause the stainless steel sheet to be slacked or off the right position. Continued use of the actuator with this condition may result in the breakage of the stainless steel sheet. Adjust the sheet tension accordingly in the regular inspection. [Refer to the maintenance section on the Instruction Manual for the procedure of stainless steel sheet tension adjustment.] Avoid using an actuator with no brake in the vertical orientation.
2	Attachment Surface	<ul style="list-style-type: none"> The base has to have a structure with sufficient rigidity to prevent oscillation. The side and the bottom surfaces of the base of the slider type actuator are the datums for the slider actuator. If accuracy for its run is required, use these surfaces as a datums of the installation.  <ul style="list-style-type: none"> The actuator mounting surface and other surfaces that are used as a datum should be flat enough with an accuracy of machining or equivalent treatment, and the flatness of the mounting surface needs to be $\pm 0.05\text{mm/m}$ or less. Secure the space where maintenance work can be performed.
3	Bolts to be used	<ul style="list-style-type: none"> For the bolts to be used, a high-tensile bolt complying with ISO-10.9 or more is recommended. If using the tapped holes, use screws with the thread length dimension being less than the effective depth of the holes. In case the tapped hole is a through hole, be careful so the screw tip does not exceed the surface of the tapped hole. For the actuator mounting, use a bolt with the dimension of its effective mating length to the tapped hole size as stated below. If tapped hole in steel \rightarrow thread length same as nominal diameter. If tapped hole in aluminum \rightarrow thread length 2 times longer than nominal diameter. When using a foot base for installation to a platform or equivalent, in order to protect the foot base, apply washers dedicated for high-tensile bolt if using bolts of M8 or larger. No washer is needed for M6 or smaller bolts. Also, do not use a normal washer.
4	Tightening Torque	<ul style="list-style-type: none"> Please follow the specification values stated in the Instruction Manual for the tightening torque. Failure to do so may cause an operation problem.
5	Load Moment and Overhung length	<ul style="list-style-type: none"> Please follow the specification values stated in the Instruction Manual for the load moment and the overhung length. Failure to do so may cause abnormal vibration or noise, and also may remarkably shorten the product life. Please do not apply any external force from other than rod moving direction (axial load) to the rod. Any perpendicular or radial force to the rod may cause damage to the actuator or operation problem. Use an actuator with a guide or equip the actuator with an optional guide if the actuator receives an external force from the direction other than its moving direction.
6	Stainless sheet	<ul style="list-style-type: none"> Please do not hold the stainless steel sheet directly with hands. Please, also, be careful not to make a dent in the stainless steel sheet. Stainless sheet is easy to get dented because it is thin. Using it with a dent in it may cause a breakage. If there is dust or metal contamination attached to the stainless steel sheet, please wipe it off the sheet surface. Operation with the stainless sheet that has foreign matters on its surface may cause problems such as sheet damage, waviness, etc. inside the slider. Please do not operate the unit in the ambient with dust or metal contamination.

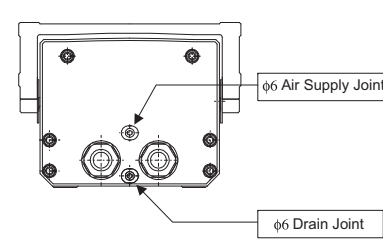
No.	Item	Precautions
7	Air Purge for Splash-Proof Type ISWA and ISPWA	<p>Air supply from the air purge should be applied on the upper quick joint (O.D. $\phi 6$) equipped on the rear cover. The lower quick joint is used as a drain (to withdraw water) in the case that water gets inside the actuator. Connect a $\phi 6$ air tube and take it to a place where no water dust gets in to withdraw water.</p>  <ul style="list-style-type: none"> • Actuator Air Pressure $\cdots 0.1\text{MPa}$ to 0.2MPa (approx. 1kgf/cm^2 to 2kgf/cm^2) • Air Flow \cdots Approx. 20 to 40NL/min • Applied Air \cdots Do not supply air directly from a compressor. Make sure to supply dry compressed air via an air drier. <u>Air to supply should not contain compressor oil and should be clean dry air that has passed the air filter with the filtration of $10\mu\text{m}$ or less and that is dried in atmospheric dew point from -15°C to -20°C.</u>

Wiring

For the controller, only the dedicated controller manufactured by our company can be used. For the connection between the actuator and controller, use the attached dedicated connection cable.

1. IS/ISP/ISA/ISPA, Stainless Steel Protection ISD/ISDA/ISPDA, Stainless Steel Protection, Clean Room Type ISDCR/ISPDCR/ISDACR/ISPDACR

1.1 Standard Cable

[Connection to the X-SEL J/K controller]

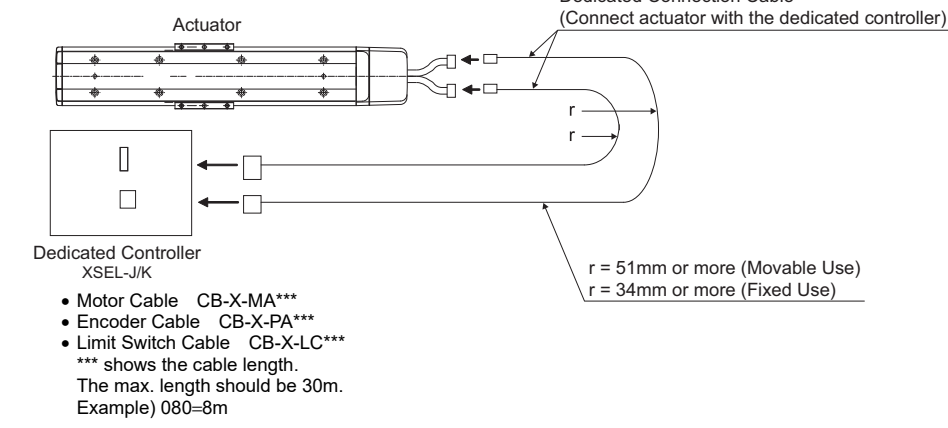

[Connection to the XSEL-P/Q/R/S/RA/SA, SSEL, SCON and MSCON controller]

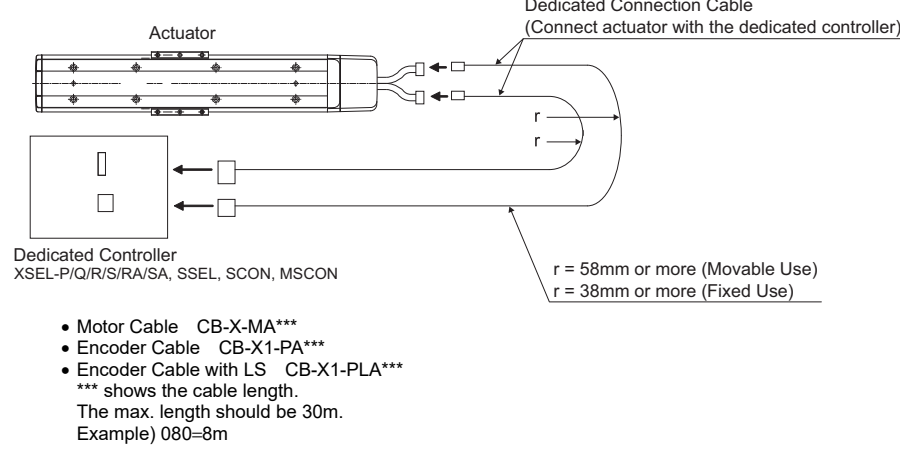

1.2 CE Compliance Cable

[Connection to the XSEL-P/Q/R/S/RA/SA, SSEL, SCON and MSCON controller]

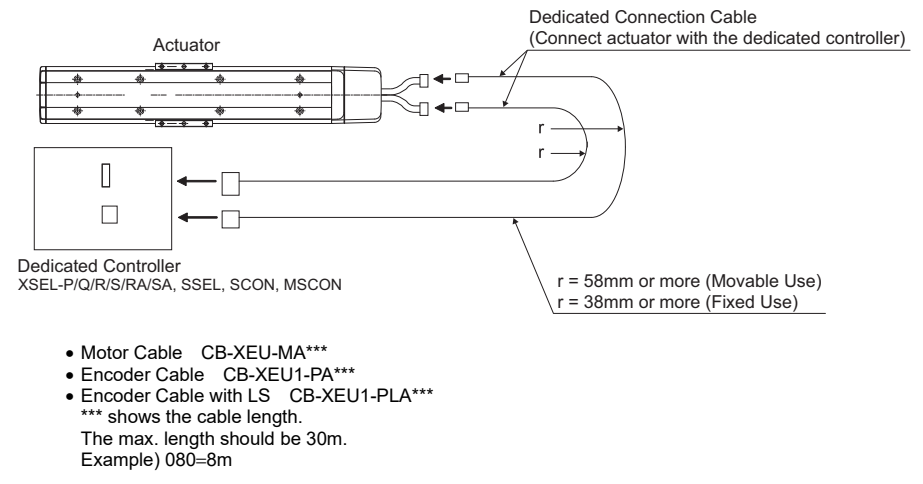

2. Splash-Proof Type ISWA/ISPWA

[Connection to the X-SEL J/K controller]

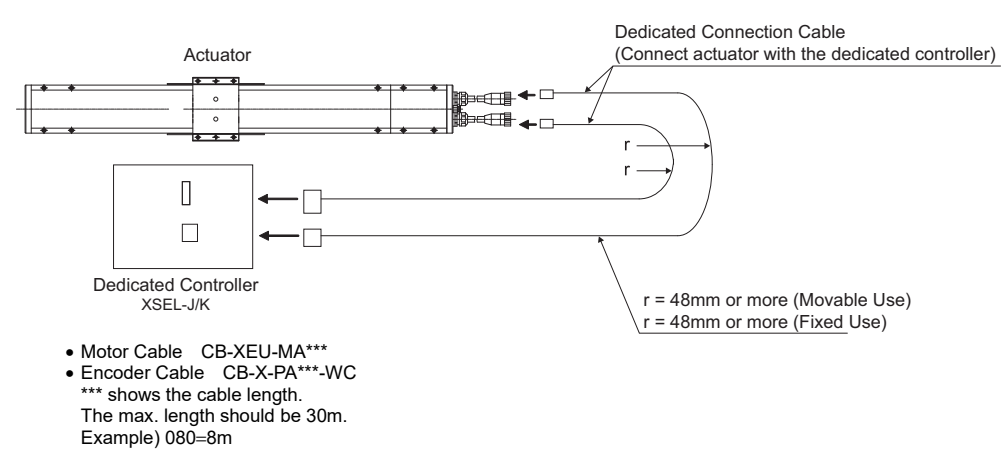

[Connection to the XSEL-P/Q/R/S/RA/SA, SSEL, SCON and MSCON controller]

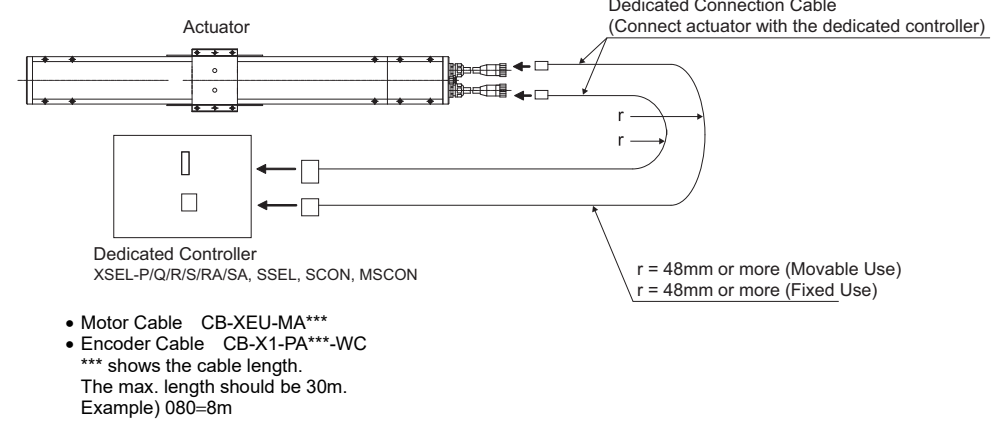

[Prohibited Items in the Cable Processing]

- Do not pull or bend forcibly the cable so as not to give any extra load or tension to the cable.
- Do not process the cable for extension or shortening by means of cutting out, combination or connecting with another cable.
- Do not let the cable flex at a single point.

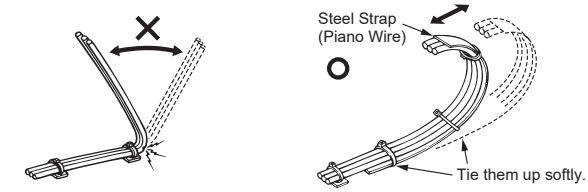

- Do not let the cable bend, kink or twist.

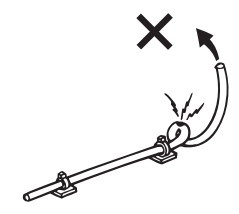

- Do not pull the cable with a strong force.

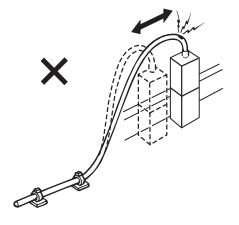

- Do not let the cable receive a turning force at a single point.

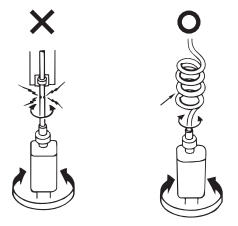

- Do not pinch, drop a heavy object onto or cut the cable.

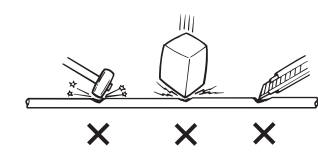

- When fixing the cable, provide a moderate slack and do not tension it too tight.

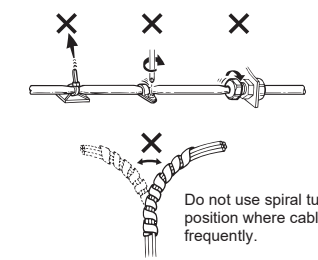

- Separate the I/O line, communication line and power line from each other. Arrange so that such lines are independently routed in the duct.

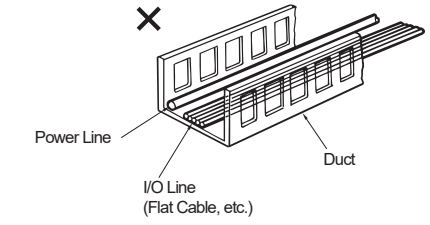

Follow the instructions below when using a cable track.

- If there is an indication to the cable for the space factor in a cable track, refer to the wiring instruction given by the supplier when storing the cable in the cable track.
 - Avoid the cables to get twined or twisted in the cable track, and also to have the cables move freely and do not tie them up. (Arrange the wiring so the cables are not to be pulled when bent.)
- Do not pile up cables. It may cause faster abrasion of the sheaths or cable breakage.

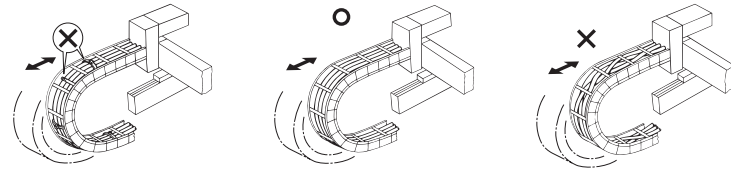

⚠ Note:

- When the cable is connected or disconnected, make sure to turn off the power to the controller. When the cable is connected or disconnected with the controller power turned ON, it might cause a malfunction of the actuator and result in a serious injury or damage to the machinery.
- When the connector connection is not correct, it would be dangerous because of a malfunction of the actuator. Make sure to confirm that the connector is connected correctly.



IAI Corporation

Head Office: 1210 Iharacho Shimizu-KU Shizuoka City Shizuoka 424-0114, Japan
TEL +81-54-364-5105 FAX +81-54-364-2589
website: www.iai-robot.co.jp/

IAI America, Inc.

Head Office: 2690 W. 237th Street, Torrance, CA 90505
TEL +1-310-891-6015 FAX +1-310-891-0815
Chicago Office: 110 East State Parkway, Schaumburg, IL 60173
TEL +1-847-908-1400 FAX +1-847-908-1399
Atlanta Office: 1220 Kennestone Circle, Suite 108, Marietta, GA 30066
TEL +1-678-354-9470 FAX +1-678-354-9471
website: www.intelligentactuator.com

Technical Support available in Europe

IAI Industrieroboter GmbH

Ober der Röh 4, D-65824 Schwalbach am Taunus, Germany
TEL +49(0)6196-88950 FAX +49(0)6196-889524
website: www.iai-automation.com

Technical Support available in Great Britain



Duttons Way, Shadsworth Business Park, Blackburn, Lancashire, BB1 2QR, United Kingdom
TEL +44(0)1254-685900
website: www.lcautomation.com

IAI (Shanghai) Co., Ltd.

SHANGHAI JIAHUA BUSINESS CENTER A8-303, 808, Hongqiao Rd. Shanghai 200030, China
TEL +86-21-6448-4753 FAX +86-21-6448-3992
website: www.iai-robot.com

IAI Robot (Thailand) Co., Ltd.

825 PhairojKijja Tower 7th Floor, Debaratana RD., Bangna-Nuea, Bangna, Bangkok 10260, Thailand
TEL +66-2-361-4458 FAX +66-2-361-4456
website: www.iai-robot.co.th