



# Horizontal Articulated Robot IX Series

## First Step Guide Fourth Edition

Thank you for purchasing our product. Make sure to read the Safety Guide and detailed Instruction Manual as well as this First Step Guide to ensure correct use. This Instruction Manual is original.

**Warning :** Read the instruction manual carefully and follow the instruction manual when handling this equipment. Please download the user's manual from our website. You can download it free of charge. User registration is required for first time users. URL: www.iai-robot.co.jp/data\_d/CAD\_MANUAL/ Keep a printout of the introduction manual near the equipment in which this product is installed so that it can be checked at all times, or display it on your computer, tablet terminal, etc. so that you can check it immediately. If you need a bound copy of the instruction manual, order it from the nearest sales office listed in the First Step Guide or at the end of the instruction manual. It will be provided for a fee.

- Using or copying all or part of this Instruction Manual without permission is prohibited.
- The company names, names of products and trademarks of each company shown in the sentences are registered trademarks.

### Product Check

This product is comprised of the following parts if it is of standard configuration. If you find any fault in the contained model or any missing parts, contact us or our distributor.

#### 1. Parts (The option is excluded.)

##### 1.1 IX-NN□1205/1505/1805

No.	Part Name	Remarks
1	Main Body	[Refer to "2. How to read the model No.", "3.1 How to read the model"]
2	Dedicated Controller	
Accessories		
3	Receptacle Housing	
4	Pin Contact	
5	PIO flat cable	CB-X-PIO***
6	Safety Guide	M0194

##### 1.2 IX-□□N2515(H)/3015(H)/3515(H)/50□□(H)/60□□(H)/70□□(H)/80□□(H) IX-NNC2515(H)/3015(H)/3515(H)/50□□(H)/60□□(H)/70□□(H)/80□□(H)

No.	Part Name	Remarks
1	Main Body	[Refer to "2. How to read the model No.", "3.2 How to read the model"]
2	Dedicated Controller	
Accessories		
3	Eyebolt	
4	D-sub connector	
5	Hood set (for D-sub connector)	
6	Caution label	
7	Positioning label	
8	PIO flat cable	CB-X-PIO***
9	Safety Guide	M0194

##### 1.3 IX-NNW2515(H)/3015(H)/3515(H)/50□□(H)/60□□(H)/70□□(H)/80□□(H)

No.	Part Name	Remarks
1	Main Body	[Refer to "2. How to read the model No.", "3.2 How to read the model"]
2	Dedicated Controller	
Accessories		
3	Eyebolt	
4	Water-proof Connector	
5	Hood set (for Water-proof connector)	
6	Caution label	
7	Positioning label	
8	PIO flat cable	CB-X-PIO***
9	Safety Guide	M0194

#### 2. How to read the model No.

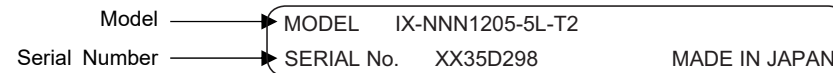

#### 3. How to read the model

##### 3.1 IX-NN□1205/1505/1805

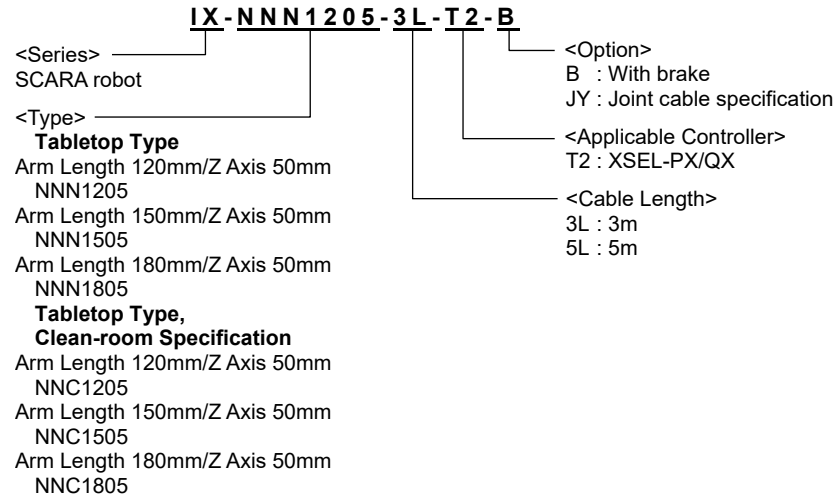

##### 3.2 IX-□□□2515(H)/3015(H)/3515(H)/50□□(H)/60□□(H)/70□□(H)/80□□(H)

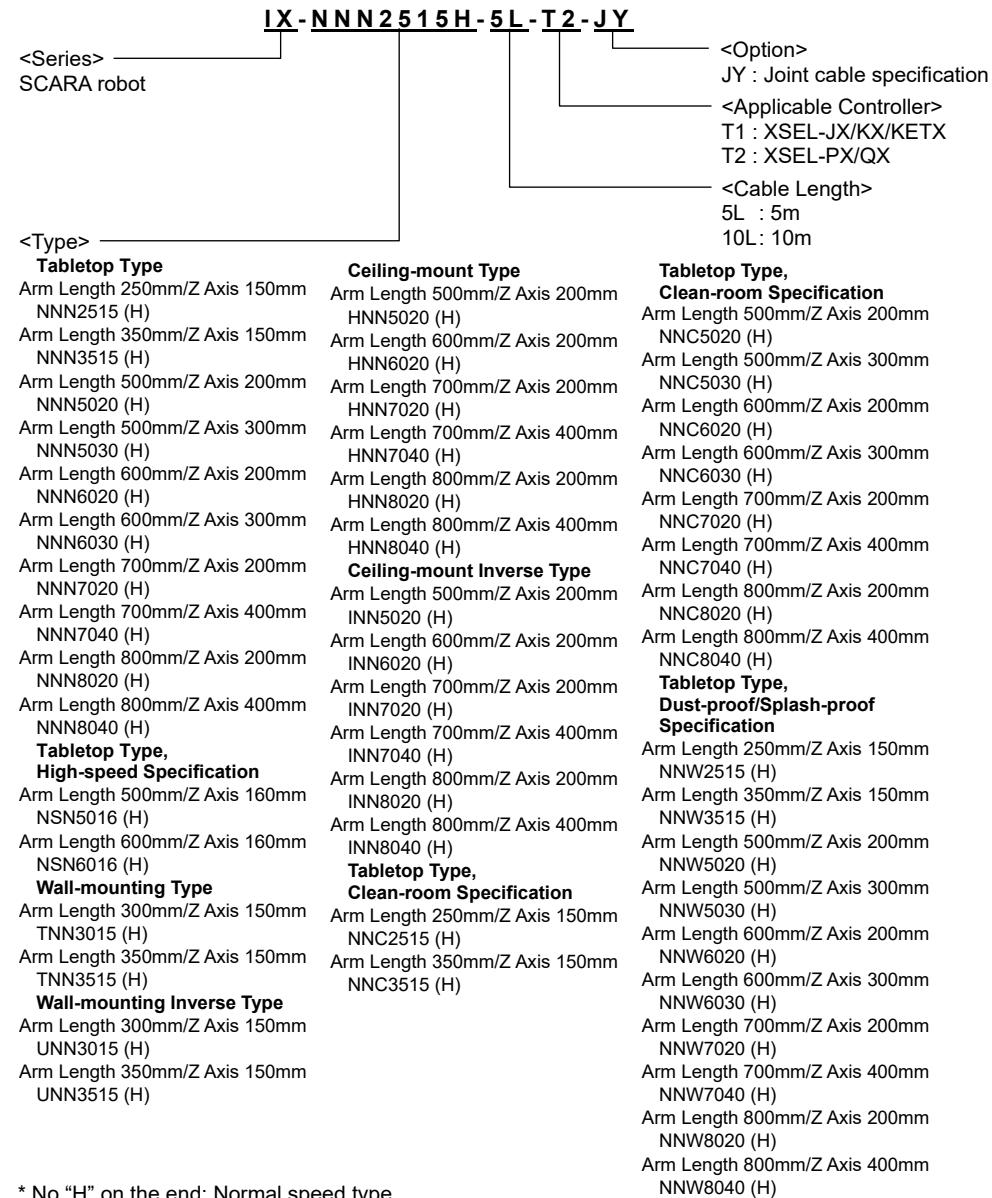

\* No "H" on the end: Normal speed type  
With "H": New Product (improved in high-speed performance)  
\* XSEL-JX/KX/KETX controllers cannot be applied to the newly released (high-speed performance) SCARA robot.

### Precautions in Handling

#### 1. Handling of Robot

##### 1.1 Handling of the Carton

The robot is packaged together with a dedicated controller. Exercise caution to the items below when transporting the robot in the package.

- Do not apply damage or drop. The package is not applied with any special treatment that enables it to resist an impact caused by a drop or crash.
- Transport a heavy package with at least more than two operators. Transport it using an appropriate transportation measure.
- Support the reinforced frame of the pallet when hanging the carton with ropes. When using a forklift to lift the carton, support the reinforced pallet.
- Do not apply an impact on the package or let it bounce when putting it down.
- Do not climb on the carton.
- Do not put any load that may cause a deformation or breakage of the package.

##### 1.2 Handling of Robot without Package

- Fix the robot arm in advance to transportation to avoid the arm moving accidentally.
- When transporting the robot, affix the arms using the supplied arm fixing plate.
- Wrap the cables around the base and secure them with gummed tape or other means.
- Tie up the arm properly so the tip of the arm does not swing largely effected by the external vibration.
- In the case that the robot needs to be carried up with ropes or another method, be sure to use an appropriate cushioning to avoid the robot being deformed or put on an excessive pressure. And also, be sure to keep the robot in a stable and horizontal posture.
- Use a dolly, forklift, crane or other appropriate equipment for transportation. When transporting the robot, move it slowly by maintaining balance and safeguarding against vibration or impact.
- Be sure not to apply load onto the cover and the connectors on the main body. Also, avoid the cables being pinched or caused an excessive deformation.
- When handling multiple robots at the same time, exercise caution so the controllers are mounted to the wrong robot.

#### 2. Handling of Robot Mounted on Mechanical Equipment (System)

Note the followings when the whole mechanical equipment (system) that the robot is mounted on needs to be transported.

- Fix the robot arm in advance to transportation to avoid the arm moving accidentally.
- Tie up the arm properly enough so the tip of the arm does not swing. When hanging up the equipment (system) with ropes or another method, make sure not to apply load onto the robot main body, connector, and so on. Also, avoid the cables being pinched or causing excessive deformation.

### Installation Environment, Storage Environment

#### 1. Installation Environment

An environment that satisfies the following conditions is required during installation. Generally speaking, it should be an environment where a worker can work without any protective gear.

- There should be no direct sunlight.
- Any radiant heat from a large heat source such as heat treatment furnace should not be directed at the machine main body.
- The ambient temperature should be 0 to 40°C.
- The relative humidity should be 20% or more, 85% or less. There should not be dew condensation.
- There should not be corrosive gas or flammable gas.
- It should be a normal assembling work environment where there is not too much dust.
- Oil mist or cutting liquid should not be directed at the machine.
- Chemical liquid should not be splashed on it.
- An impact or vibration should not be transmitted to it.
- There should not be strong electromagnetic waves, ultraviolet rays or radiation.
- The working space required for maintenance or inspection should be secured.

#### 2. Storage and Preservation Environment

- The storage and preservation environment should comply with the same standards as those for the installation environment. In particular, when the machine is to be stored for a long time, pay close attention to environmental conditions so that no condensation forms. Unless specially specified, moisture absorbcency protection is not included in the package when the machine is delivered. In the case that the machine is to be stored and preserved in an environment where condensation is anticipated, take the condensation preventive measures from outside of the entire package, or directly after opening the package.
- In the storage and preservation for up to 1 month, it can endure in the temperature at 60°C at maximum. For the storage and preservation longer than that, keep the temperature at 50°C at maximum.

# External Dimensions

## 1. IX-NNN1205/1505/1805

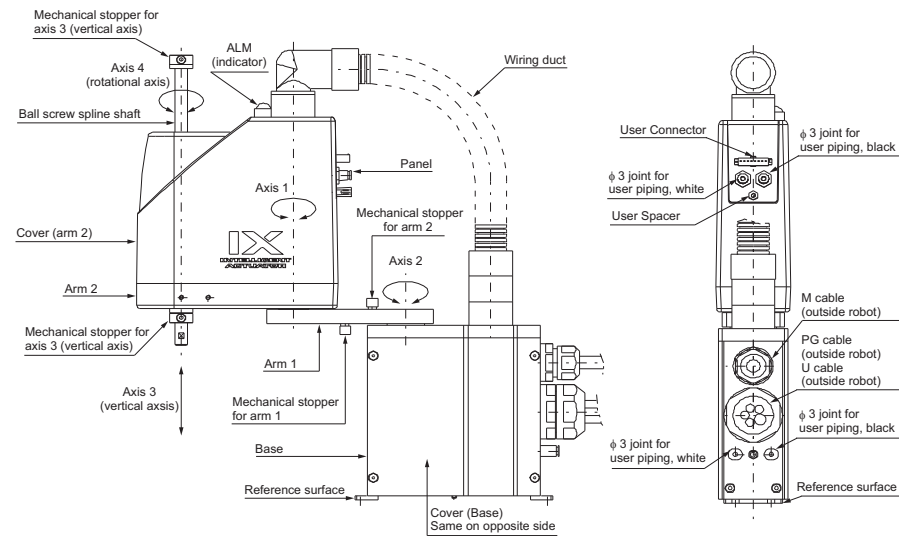

## 2. IX-NNN2515(H)/3515(H)

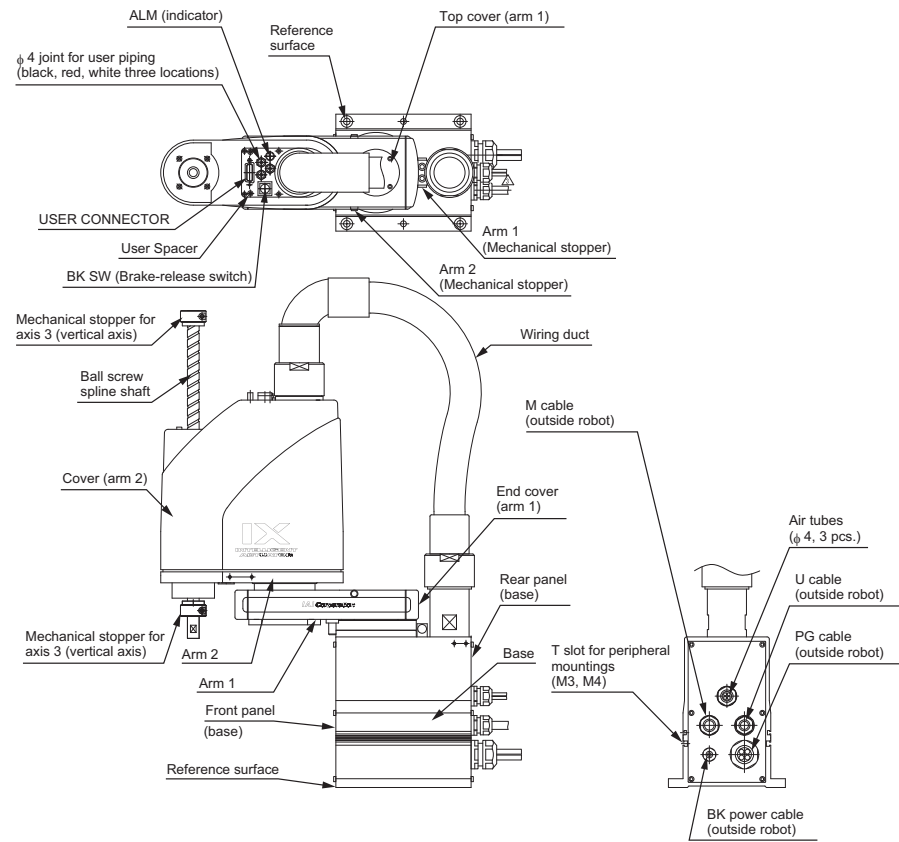

[Refer to the catalog or Operation Manual for the detail of outline and attachments dimensions.]

## 3. IX-NNN50(H)/60(H)/70(H)/80(H)

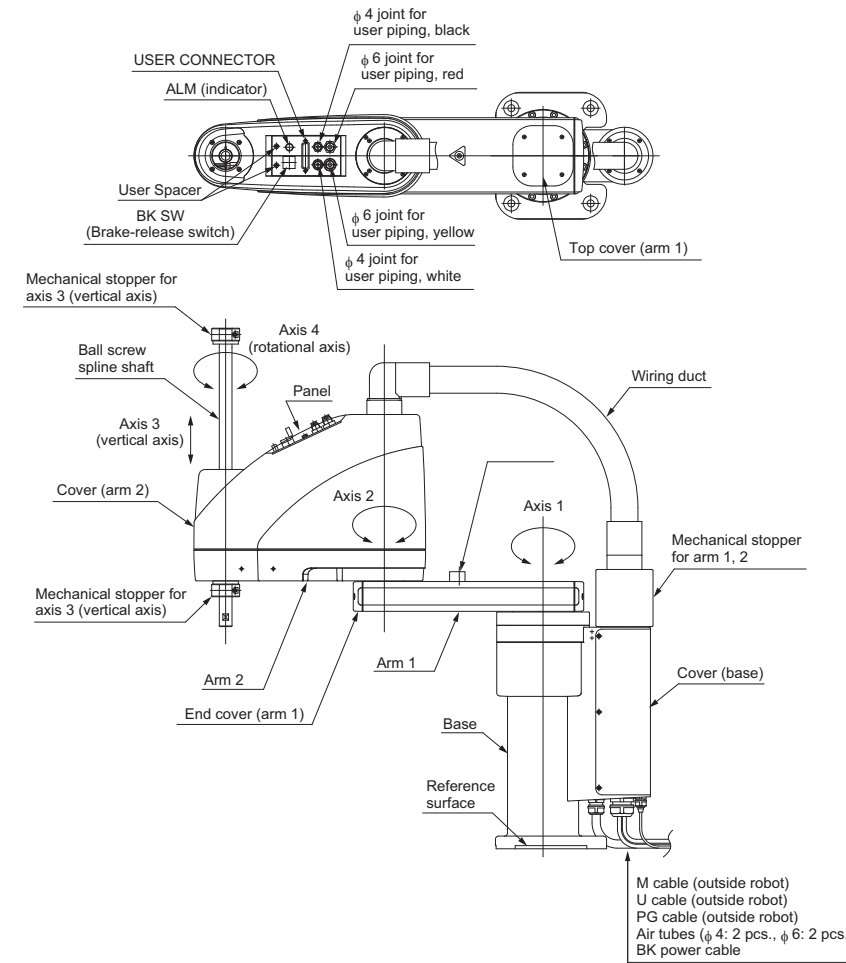

## 4. IX-TNN3015(H)/3515(H), UNN3015(H)/3515(H)

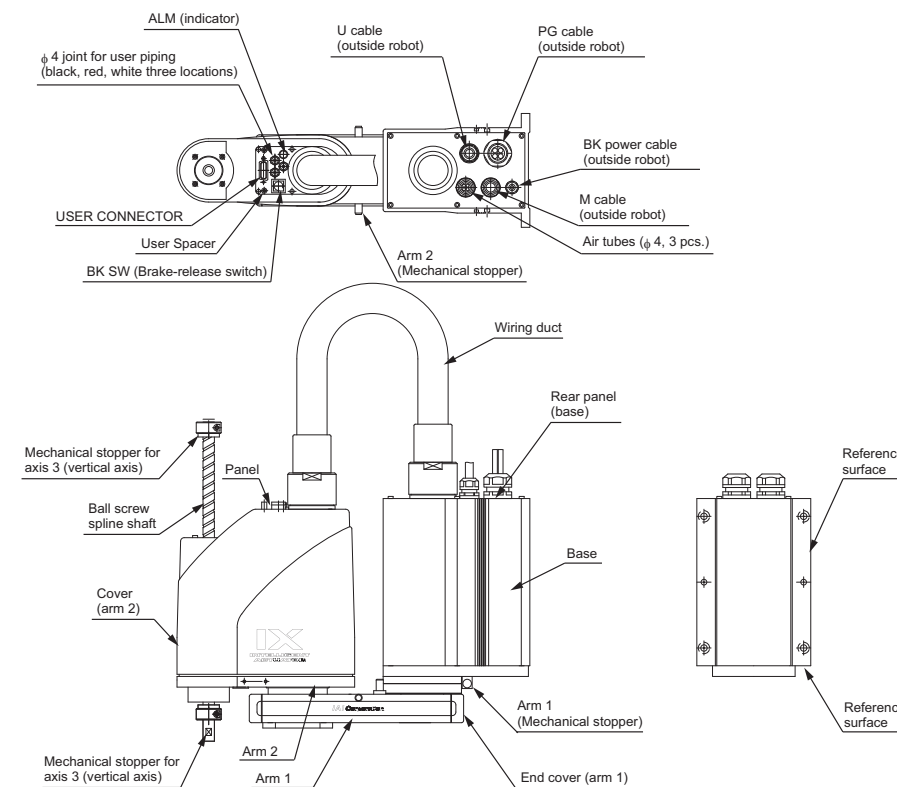

\* The direction of attachment profile for the inverse type is opposite in up-down direction.

[Refer to the catalog or Operation Manual for the detail of outline and attachments dimensions.]

## 5. IX-UNN50(H)/60(H)/70(H)/80(H) IX-INN50(H)/60(H)/70(H)/80(H)

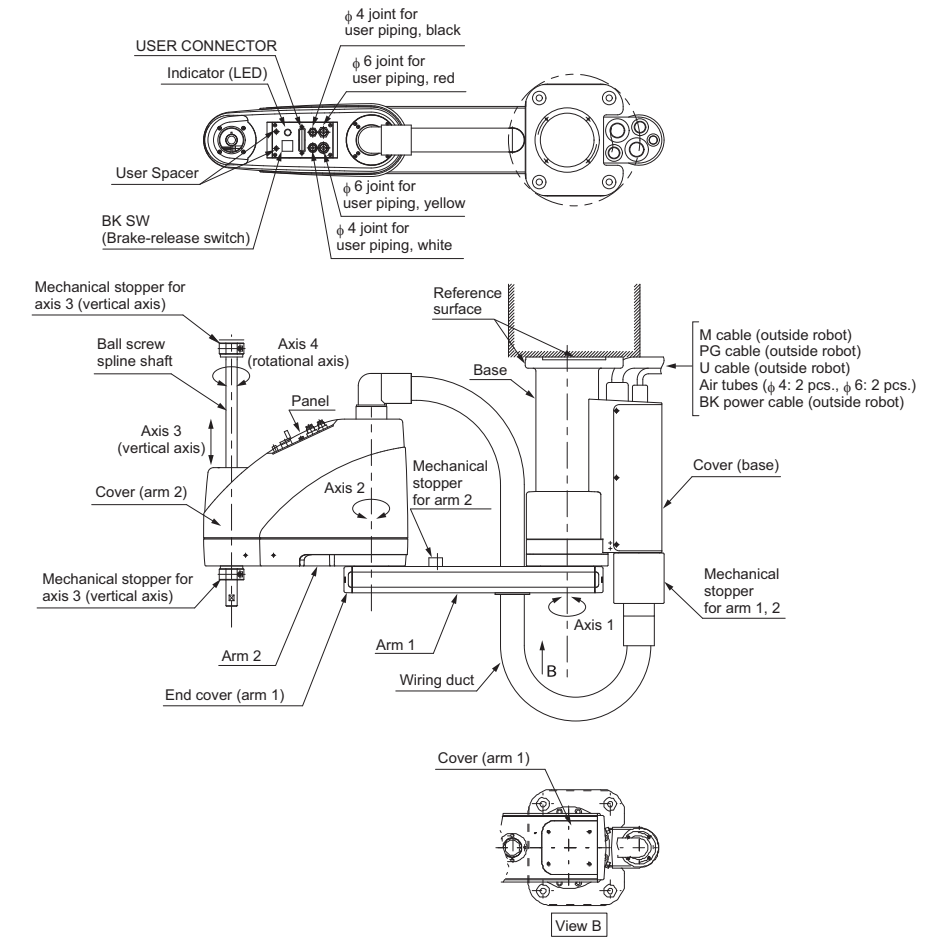

\* The direction of attachment profile for the inverse type is opposite in up-down direction.

## 6. IX-NNC1205/1505/1805

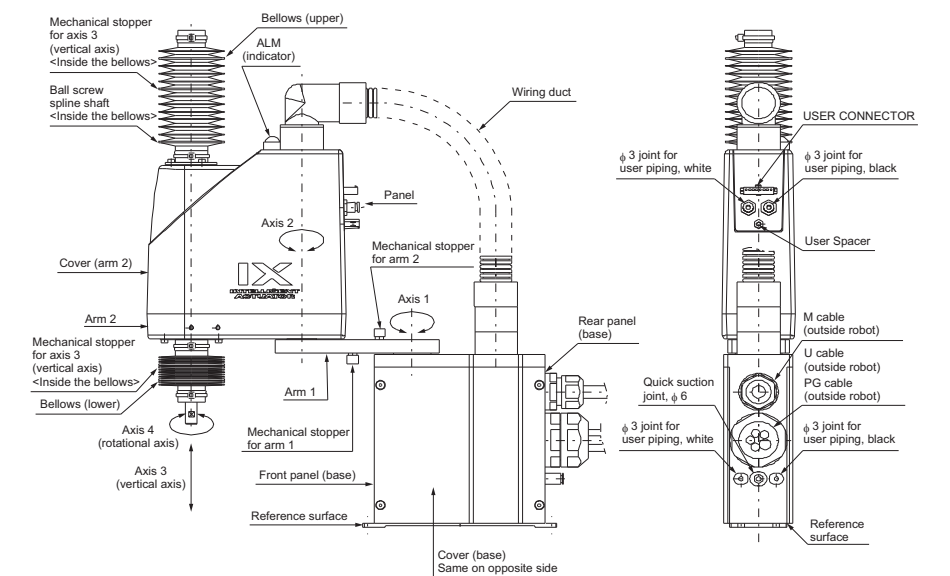

[Refer to the catalog or Operation Manual for the detail of outline and attachments dimensions.]

7. IX-NNC2515(H)/3515(H)

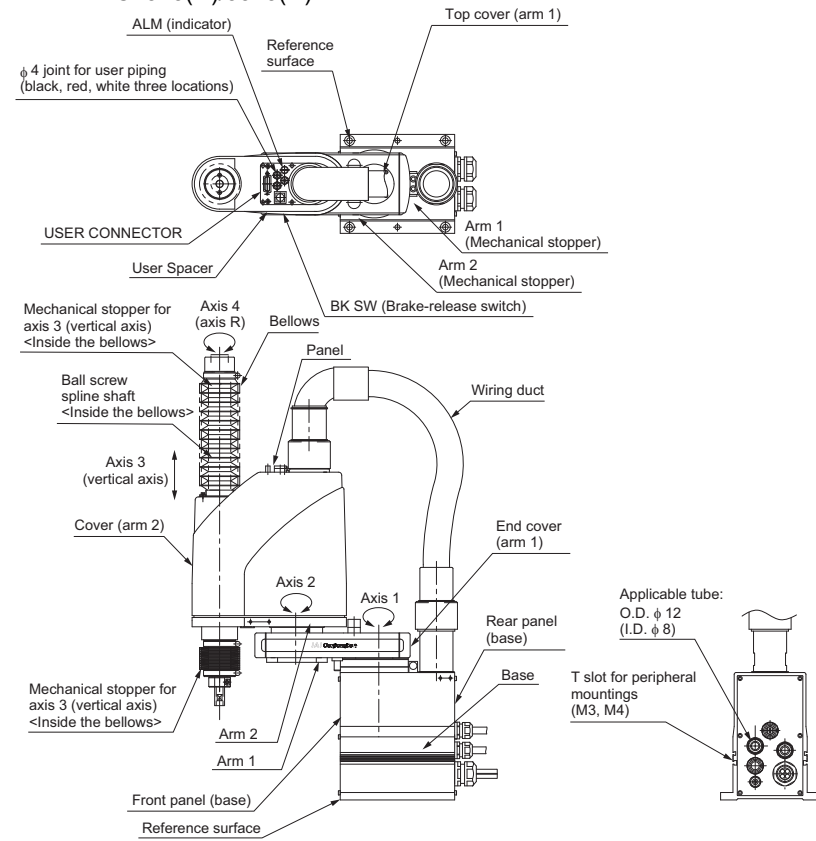

8. IX-NNC50□□(H)/60□□(H)/70□□(H)/80□□(H)

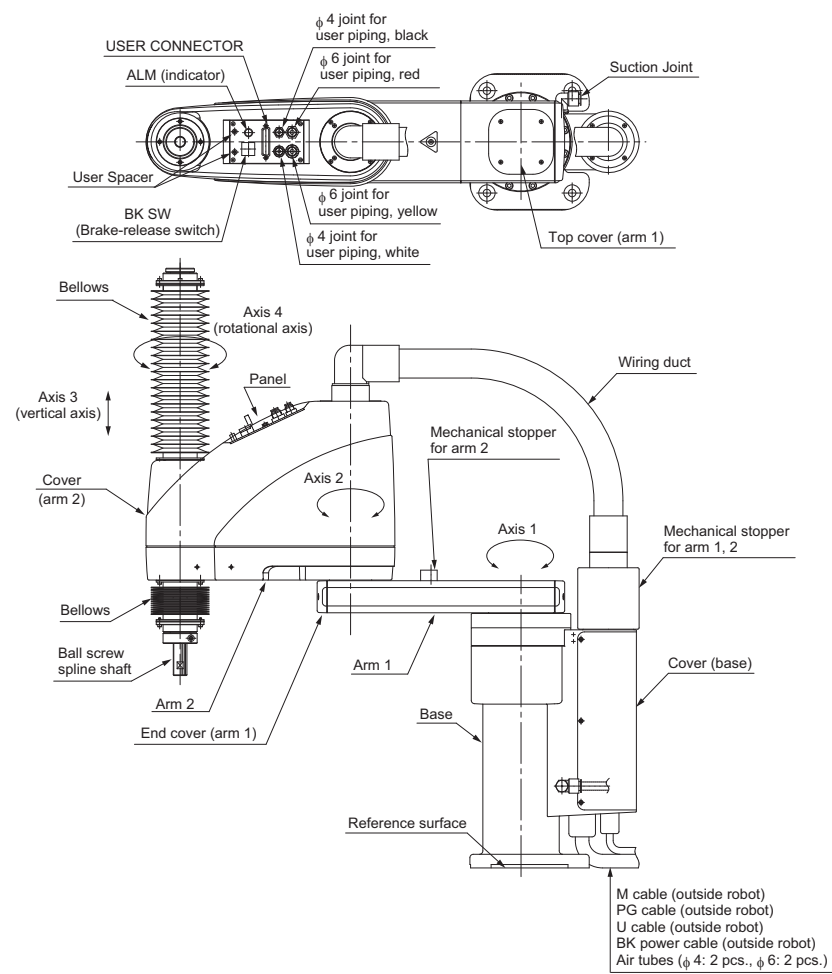

[Refer to the catalog or Operation Manual for the detail of outline and attachments dimensions.]

9. IX-NNW2515(H)/3515(H)

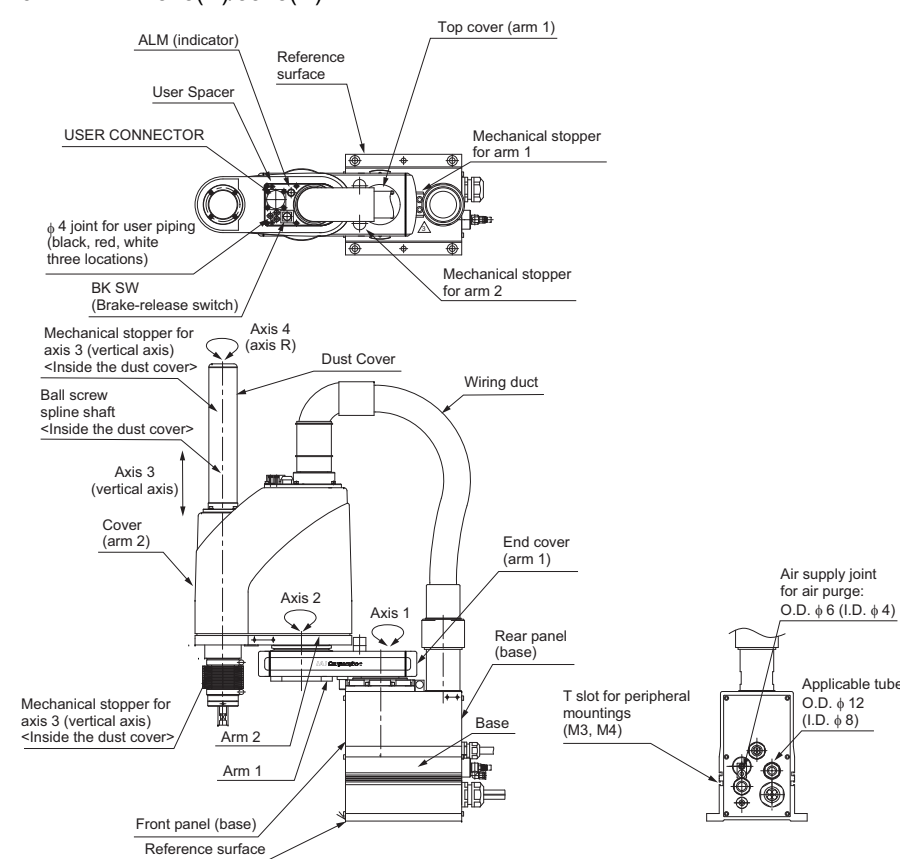

10. IX-NNW50□□(H)/60□□(H)/70□□(H)/80□□(H)

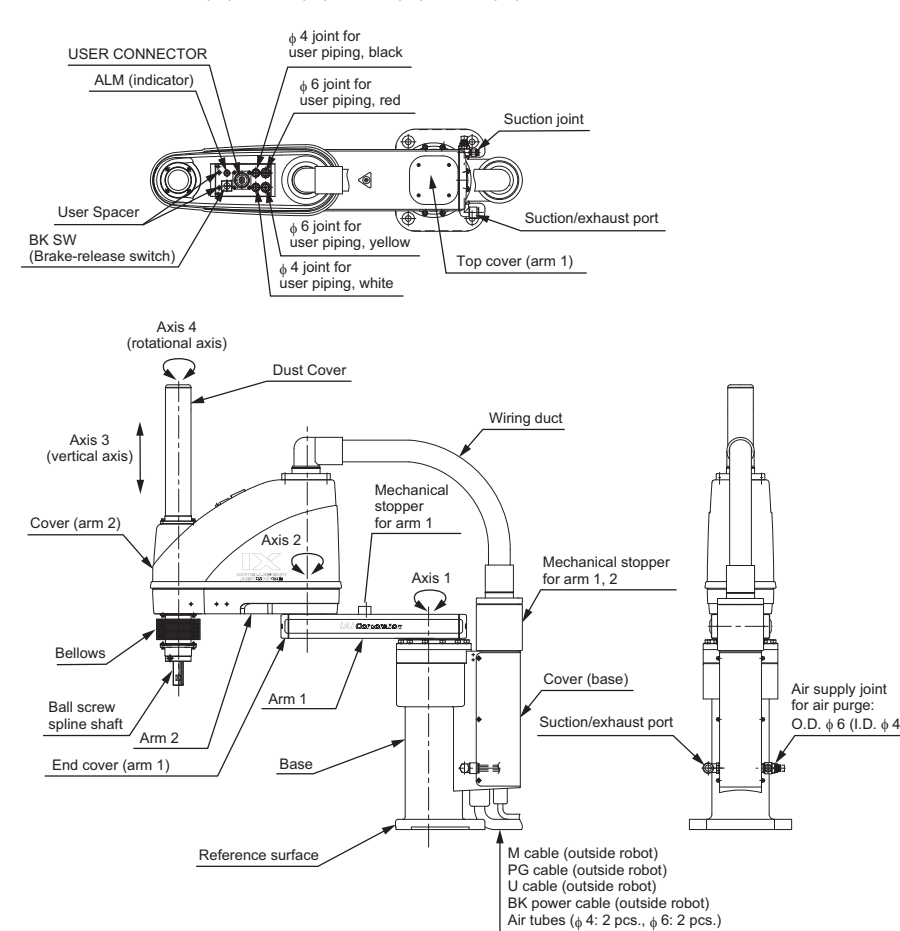

[Refer to the catalog or Operation Manual for the detail of outline and attachments dimensions.]

Installation

1. Platform

The platform to mount the robot receives an enormous reactive force. Be certain to prepare a platform with rigidity enough to withstand the force.

- Thickness of the Robot Mounting Surface on Platform

Model	Surface Thickness
IX-NN□1205/1505/1805	8mm
IX-□□□2515(H)/3015(H)/3515(H)/50□□(H)/60□□(H)/70□□(H)/80□□(H)	25mm

- Parallelism of the platform horizontal surface  
Create the horizontal surface with an accuracy of ±0.05 or more.
- Drill tapped holes, as indicated below, into the installation surface of the platform.

Model	Tap size	Remarks
IX-NN□1205/1505/1805	M3 or M4	M3: Effective thread: 3 mm or longer for steel (6 mm or longer for aluminum) M4: Effective thread: 4 mm or longer for steel (8 mm or longer for aluminum)
IX-□N□2515(H)/3015(H)/3515(H)	M8	M8: Effective thread: 10 mm or longer for steel (20 mm or longer for aluminum)
IX-□□□50□□(H)/□□□60□□(H)	M10	M10: Effective thread: 10 mm or longer for steel (20 mm or longer for aluminum)
IX-□□□70□□(H)/□□□80□□(H)	M12	M12: Effective thread: 12 mm or longer for steel (24 mm or longer for aluminum)

- The platform must have sufficient rigidity to withstand not only the weight of the robot but also the dynamic moment of inertia that is generated when the robot is operated at maximum speed.
- Secure the platform to the floor or other rigid structure in a manner that prevents any movement due to operation of the robot.
- The installation platform must allow the robot to be mounted on a level surface.

2. Installation of the Robot

Install the robot on a level surface.

Secure the robot using hex bolts and washers.

Model	Bolts size	Tightening torque	Remarks
IX-NN□1205/1505/1805	M3	0.81N·m	Make sure to use a plain washer. (O.D. φ 7, I.D. φ 3.2, t = 0.5) Washer outer diameter exceeds the datum surface in the case using a plain washer for M4 size. Apply a plain washer only if the use of it does not cause any problem to your robot use.
	M4	1.41N·m	
IX-□N□2515(H)/3015(H)/3515(H)	M8	3.2N·m	
IX-□□□50□□(H)/□□□60□□(H)	M10	60N·m	
IX-□□□70□□(H)/□□□80□□(H)	M12	104N·m	

For the hex bolts, use high-tension bolts with an ISO rating of 10.9 or higher.

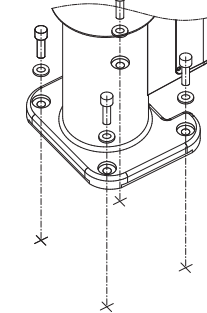

Warning Caution

- Always insert a washer below each bolt. Without a washer, the bolt-bearing surface may sink.
- Tighten the hex bolts securely to the correct torque. Improperly tightened bolts may reduce the accuracy of robot operation, and in the worst case cause the robot to overturn.

3. Checking after Installation

Once the robot has been installed, check the following items:

- Visually check the robot, controller and cables for dents and other abnormalities.
- Confirm that the cables are connected properly and that the connectors are inserted securely.

Warning

- Failure to perform these checks may result in a malfunctioning robot or a damaged controller or robot.

# Wiring

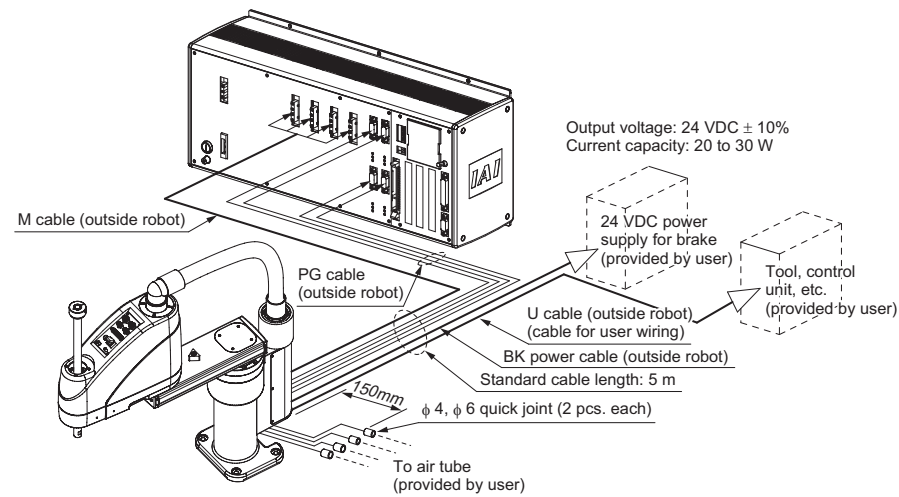

(Note) 24 VDC brake cable from robot main body is not included in IX-NN□1205/1505/1805.

The controller connection cables are attached on the robot.

Pay attention to the following items when connecting the controller:

- Connect to the robot of the serial number specified on the robot designation label provided on the front panel of the controller.

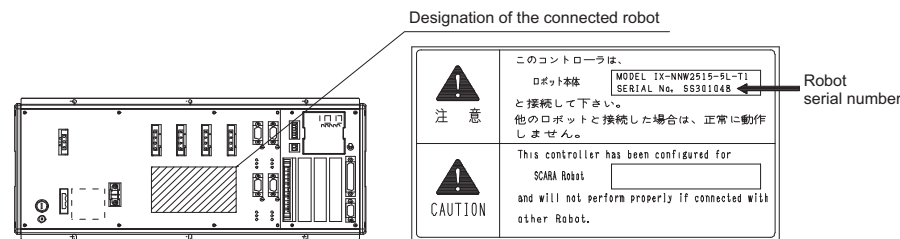

- Connect the cables securely after confirming that they are free from damage or bent connector pins.
- Connect each cable by aligning the indication on the marking tube on the cable with the indication on the controller panel.
- When installing the PG connector (D-sub connector), ensure correct orientation of the connector.
- Prepare a 24 VDC power supply dedicated to the brake power. Do not share the IO power for it. The brake power supply requires an output voltage of 24 VDC ± 10% and a current capacity of 20 to 30 watts.

Refer to the operation manuals for the controller and PC software for the procedures to connect the I/O cable, controller power cable, PC connection cable, etc.

## Warning

- Be sure to connect to the robot of the serial number specified on the front panel of the controller. The controller will not operate properly if any other robot is connected. Failure to observe this warning may cause the robot to malfunction, resulting in a serious accident.
- Before connecting or disconnecting a cable, always turn off the power to the controller. Connecting/disconnecting a cable with the power supplied to the controller may cause the robot to malfunction, resulting in a serious accident.
- Installing the connectors into the wrong sockets may cause the robot to malfunction. Be sure to check the designation on the cable with that on the controller panel before plugging in any connector.
- If the connectors are not inserted securely, the robot may malfunction and generate the risk of danger. Be sure to affix each connector with the supplied screws.

For the models other than IX-NN□1205/1505/1805, the brake-dedicated power needs to be supplied not only to the brake power cable from the SCARA robot main body, but also to the controller, if X-SEL-PX/QX controllers are used.

For IX-NN□1205/1505/1805 with a brake, brake-dedicated power supply is required to the controller.

Supply the brake power (+24 V) to the controller as shown below.

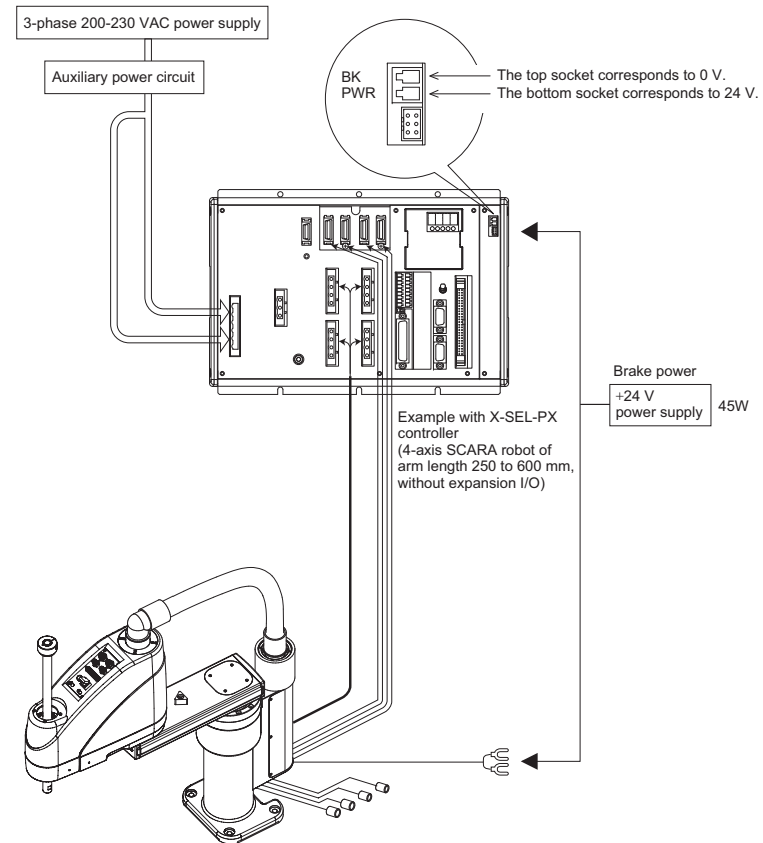

## [Prohibited Items in the Cable Processing]

- Do not pull or bend forcibly the cable so as not to give any extra load or tension to the cable.
- Do not process the cable for extension or shortening by means of cutting out, combination or connecting with another cable.
- Do not let the cable flex at a single point.

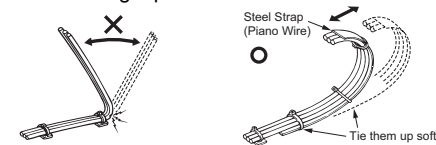

- Do not let the cable bend, kink or twist.

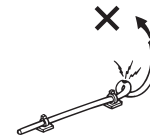

- Do not pull the cable with a strong force.

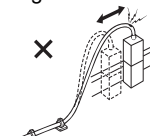

- Do not let the cable receive a turning force at a single point.

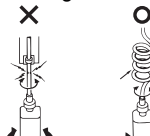

- Do not pinch, drop a heavy object onto or cut the cable.

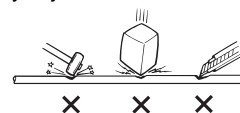

- When fixing the cable, provide a moderate slack and do not tension it too tight.

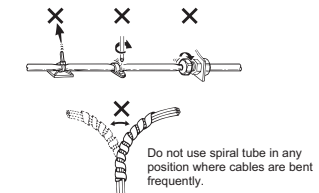

- Separate the I/O line, communication line and power line from each other. Arrange so that such lines are independently routed in the duct.

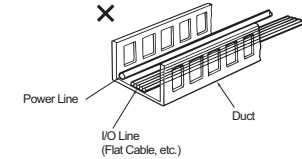

- Take care of the following items using the cable carrier.
- Arrange the wiring so that there is no entanglement or kink of the cables in the cable carrier or flexible tube, and do not bind the cables so that the cables are relatively free (Do not bend it at an angle of 90°C or less).

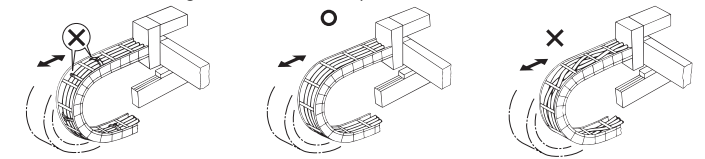

- The occupied volume rate for the cables, etc., inside the cable carrier should be 60% or less.

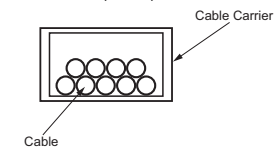

## IAI Corporation

Head Office: 1210 Iharacho Shimizu-KU Shizuoka City Shizuoka 424-0114, Japan  
TEL +81-54-364-5105 FAX +81-54-364-2589  
website: www.iai-robot.co.jp/

## IAI America, Inc.

Head Office: 2690 W. 237th Street, Torrance, CA 90505  
TEL +1-310-891-6015 FAX +1-310-891-0815  
Chicago Office: 110 East State Parkway, Schaumburg, IL 60173  
TEL +1-847-908-1400 FAX +1-847-908-1399  
Atlanta Office: 1220 Kennestone Circle, Suite 108, Marietta, GA 30068  
TEL +1-678-354-9470 FAX +1-678-354-9471  
website: www.intelligentactuator.com

Technical Support available in Europe

## IAI Industrieroboter GmbH

Ober der Röth 4, D-65824 Schwalbach am Taunus, Germany  
TEL +49(0)6196-88950 FAX +49(0)6196-889524  
website: www.iai-automation.com

Technical Support available in Great Britain

## LC Automation

control & safety

Duttons Way, Shadsworth Business Park, Blackburn, Lancashire, BB1 2QR, United Kingdom  
TEL +44(0)1254-685900  
website: www.lcautomation.com

## IAI (Shanghai) Co., Ltd.

SHANGHAI JIAHUA BUSINESS CENTER A8-303, 808, Hongqiao Rd. Shanghai 200030, China  
TEL +86-21-6448-4753 FAX +86-21-6448-3992  
website: www.iai-robot.com

## IAI Robot (Thailand) Co., Ltd.

825 PhairojKijja Tower 7th Floor, Debaratana RD., Bangna-Nuea, Bangna, Bangkok 10260, Thailand  
TEL +66-2-361-4458 FAX +66-2-361-4456  
website: www.iai-robot.co.th