



**ROBO Cylinder
RCD Actuators
Gripper Type**

Instruction Manual

==== Fourth Edition =====

Slide Type: GRSN, GRSNA

Please Read Before Use

Thank you for purchasing our product.

This instruction manual explains the handling methods, structure and maintenance of this product, providing the information you need in order to use the product safely.

Before using the product, be sure to read this manual and fully understand the contents explained herein to ensure safe use of the product.

Please download the user's manual from our website.

You can download it free of charge. User registration is required for the first time downloading.

URL : www.iai-robot.co.jp/data_dl/CAD_MANUAL/

When using the product, print out of the necessary portions of the relevant manual, or please display it on your computer, tablet terminal, etc. so that you can check it immediately.

After reading the instruction manual, keep it in a convenient place so that whoever is handling the product can refer to it quickly when necessary.

[Important]

- This instruction manual is an original document dedicated for this product.
- This product cannot be used in ways not shown in this instruction manual. IAI shall not be liable for any result whatsoever arising from the use of the product in any other way than what is noted in the manual.
- The information contained in this instruction manual is subject to change without notice for the purpose of product improvement.
- If any issues arise regarding the information contained in this instruction manual, contact our customer center or the nearest sales office.
- Use or reproduction of this instruction manual in full or in part without permission is prohibited.
- The company names, names of products and trademarks of each company shown in the text are registered trademarks.

RC ROBO
CYLINDER

Table of Contents

Safety Guide	1
Caution in Handling	8
International Standards Compliances	9
Names of the Parts	10
1. Specifications Check	12
1.1 Checking the Product	12
1.1.1 Parts	12
1.1.2 Instruction Manuals for the Controllers Related to this Product	12
1.1.3 How to Read the Model Nameplate	12
1.1.4 How to Read the Model Number	13
1.2 Specifications	14
1.2.1 Common	14
1.2.2 Relation between the Current Limit Value and the Grip Force	15
1.2.3 Allowable Static Moments	16
1.2.4 Duty in Continuous Operation	16
1.3 Operating Conditions	17
1.3.1 Grip Force	17
1.4 Motor • Encoder Cables	21
1.4.1 Motor • Encoder Integrated Cable Connection	21
1.4.2 Motor • Encoder Integrated Cables Robot Type	22
2. Installation	23
2.1 Transportation	23
2.2 Installation and Storage • Preservation Environment	25
2.3 How to Install	26
2.3.1 Installation	26
2.3.2 Installation of the Main Unit	27
2.3.3 How to Attach the Finger Attachment	29
3. Connecting with the Controller	31
4. Operation	35
4.1 Operation of the Fingers	35
4.2 Release of the Gripped Work Piece	35
5. Maintenance and Inspection	36
5.1 Inspection Items and Schedule	36
5.2 Visually Inspecting the Exterior	36
5.3 Cleaning	36
5.4 Grease Supply	37
5.4.1 Applicable Greases	37
5.4.2 How to Apply Grease	38
6. External Dimensions	39

7. Warranty.....	40
7.1 Warranty Period.....	40
7.2 Scope of the Warranty.....	40
7.3 Honoring the Warranty.....	40
7.4 Limited Liability.....	40
7.5 Conditions of Conformance with Applicable Standards/Regulations, Etc., and Applications.....	41
7.6 Other Items Excluded from Warranty.....	41
 Change History	 42

Safety Guide

“Safety Guide” has been written to use the machine safely and so prevent personal injury or property damage beforehand. Make sure to read it before the operation of this product.

Safety Precautions for Our Products

The common safety precautions for the use of any of our robots in each operation.

No.	Operation Description	Description
1	Model Selection	<ul style="list-style-type: none"> ● This product has not been planned and designed for the application where high level of safety is required, so the guarantee of the protection of human life is impossible. Accordingly, do not use it in any of the following applications. <ol style="list-style-type: none"> 1) Medical equipment used to maintain, control or otherwise affect human life or physical health. 2) Mechanisms and machinery designed for the purpose of moving or transporting people (For vehicle, railway facility or air navigation facility) 3) Important safety parts of machinery (Safety device, etc.) ● Do not use the product outside the specifications. Failure to do so may considerably shorten the life of the product. ● Do not use it in any of the following environments. <ol style="list-style-type: none"> 1) Location where there is any inflammable gas, inflammable object or explosive 2) Place with potential exposure to radiation 3) Location with the ambient temperature or relative humidity exceeding the specification range 4) Location where radiant heat is added from direct sunlight or other large heat source 5) Location where condensation occurs due to abrupt temperature changes 6) Location where there is any corrosive gas (sulfuric acid or hydrochloric acid) 7) Location exposed to significant amount of dust, salt or iron powder 8) Location subject to direct vibration or impact ● For an actuator used in vertical orientation, select a model which is equipped with a brake. If selecting a model with no brake, the moving part may drop when the power is turned OFF and may cause an accident such as an injury or damage on the work piece.

No.	Operation Description	Description
2	Transportation	<ul style="list-style-type: none"> • When carrying a heavy object, do the work with two or more persons or utilize equipment such as crane. • When the work is carried out with 2 or more persons, make it clear who is to be the “leader” and who to be the “follower(s)” and communicate well with each other to ensure the safety of the workers. • When in transportation, consider well about the positions to hold, weight and weight balance and pay special attention to the carried object so it would not get hit or dropped. • Transport it using an appropriate transportation measure. The actuators available for transportation with a crane have eyebolts attached or there are tapped holes to attach bolts. Follow the instructions in the instruction manual for each model. • Do not step or sit on the package. • Do not put any heavy thing that can deform the package, on it. • When using a crane capable of 1t or more of weight, have an operator who has qualifications for crane operation and sling work. • When using a crane or equivalent equipments, make sure not to hang a load that weighs more than the equipment’s capability limit. • Use a hook that is suitable for the load. Consider the safety factor of the hook in such factors as shear strength. • Do not get on the load that is hung on a crane. • Do not leave a load hung up with a crane. • Do not stand under the load that is hung up with a crane.
3	Storage and Preservation	<ul style="list-style-type: none"> • The storage and preservation environment conforms to the installation environment. However, especially give consideration to the prevention of condensation. • Store the products with a consideration not to fall them over or drop due to an act of God such as earthquake.
4	Installation and Start	<p>(1) Installation of Robot Main Body and Controller, etc.</p> <ul style="list-style-type: none"> • Make sure to securely hold and fix the product (including the work part). A fall, drop or abnormal motion of the product may cause a damage or injury. Also, be equipped for a fall-over or drop due to an act of God such as earthquake. • Do not get on or put anything on the product. Failure to do so may cause an accidental fall, injury or damage to the product due to a drop of anything, malfunction of the product, performance degradation, or shortening of its life. • When using the product in any of the places specified below, provide a sufficient shield. <ol style="list-style-type: none"> 1) Location where electric noise is generated 2) Location where high electrical or magnetic field is present 3) Location with the mains or power lines passing nearby 4) Location where the product may come in contact with water, oil or chemical droplets

No.	Operation Description	Description
4	Installation and Start	<p>(2) Cable Wiring</p> <ul style="list-style-type: none"> ● Use our company's genuine cables for connecting between the actuator and controller, and for the teaching tool. ● Do not scratch on the cable. Do not bend it forcibly. Do not pull it. Do not coil it around. Do not insert it. Do not put any heavy thing on it. Failure to do so may cause a fire, electric shock or malfunction due to leakage or continuity error. ● Perform the wiring for the product, after turning OFF the power to the unit, so that there is no wiring error. ● When the direct current power (+24V) is connected, take the great care of the directions of positive and negative poles. If the connection direction is not correct, it might cause a fire, product breakdown or malfunction. ● Connect the cable connector securely so that there is no disconnection or looseness. Failure to do so may cause a fire, electric shock or malfunction of the product. ● Never cut and/or reconnect the cables supplied with the product for the purpose of extending or shortening the cable length. Failure to do so may cause the product to malfunction or cause fire. <p>(3) Grounding</p> <ul style="list-style-type: none"> ● The grounding operation should be performed to prevent an electric shock or electrostatic charge, enhance the noise-resistance ability and control the unnecessary electromagnetic radiation. ● For the ground terminal (PE) on the AC power cable of the controller and the grounding plate in the control panel, make sure for grounding work. For security grounding, it is necessary to select an appropriate wire thickness suitable for the load. Perform wiring that satisfies the specifications (electrical equipment standards and criteria). For detail, follow the description in [an instruction manual of each controller or controller built-in actuator]. ● Conduct functional grounding on the FG terminal for a controller supplying 24V DC or a controller built-in type actuator. In order to minimize influence to mechanical operation given by electromagnetic interference (noise) to an electrical device or insulation failure, conduct grounding on a terminal or a conductor that is electrically stable. The reference impedance should be Type D (Former Class 3, ground resistance 100Ω or less).





No.	Operation Description	Description
4	Installation and Start	<p>(4) Safety Measures</p> <ul style="list-style-type: none"> ● When the work is carried out with 2 or more persons, make it clear who is to be the “leader” and who to be the “follower(s)” and communicate well with each other to ensure the safety of the workers. ● When the product is under operation or in the ready mode, take the safety measures (such as the installation of safety and protection fence) so that nobody can enter the area within the robot’s movable range. When the robot under operation is touched, it may result in death or serious injury. ● Make sure to install the emergency stop circuit so that the unit can be stopped immediately in an emergency during the unit operation. ● Take the safety measure not to start up the unit only with the power turning ON. Failure to do so may start up the machine suddenly and cause an injury or damage to the product. ● Take the safety measure not to start up the machine only with the emergency stop cancellation or recovery after the power failure. Failure to do so may result in an electric shock or injury due to unexpected power input. ● When the installation or adjustment operation is to be performed, give clear warnings such as “Under Operation; Do not turn ON the power!” etc. Sudden power input may cause an electric shock or injury. ● Take the measure so that the work part is not dropped in power failure or emergency stop. ● Wear protection gloves, goggle or safety shoes, as necessary, to secure safety. ● Do not insert a finger or object in the openings in the product. Failure to do so may cause an injury, electric shock, damage to the product or fire. ● When releasing the brake on a vertically oriented actuator, exercise precaution not to pinch your hand or damage the work parts with the actuator dropped by gravity.
5	Teaching	<ul style="list-style-type: none"> ● When the work is carried out with 2 or more persons, make it clear who is to be the “leader” and who to be the “follower(s)” and communicate well with each other to ensure the safety of the workers. ● Perform the teaching operation from outside the safety protection fence, if possible. In the case that the operation is to be performed unavoidably inside the safety protection fence, prepare the “Stipulations for the Operation” and make sure that all the workers acknowledge and understand them well. ● When the operation is to be performed inside the safety protection fence, the worker should have an emergency stop switch at hand with him so that the unit can be stopped any time in an emergency. ● When the operation is to be performed inside the safety protection fence, in addition to the workers, arrange a watchman so that the machine can be stopped any time in an emergency. Also, keep watch on the operation so that any third person can not operate the switches carelessly. ● Place a sign “Under Operation” at the position easy to see. ● When releasing the brake on a vertically oriented actuator, exercise precaution not to pinch your hand or damage the work parts with the actuator dropped by gravity. <p>* Safety protection Fence : In the case that there is no safety protection fence, the movable range should be indicated.</p>

No.	Operation Description	Description
6	Trial Operation	<ul style="list-style-type: none"> ● When the work is carried out with 2 or more persons, make it clear who is to be the “leader” and who to be the “follower(s)” and communicate well with each other to ensure the safety of the workers. ● After the teaching or programming operation, perform the check operation one step by one step and then shift to the automatic operation. ● When the check operation is to be performed inside the safety protection fence, perform the check operation using the previously specified work procedure like the teaching operation. ● Make sure to perform the programmed operation check at the safety speed. Failure to do so may result in an accident due to unexpected motion caused by a program error, etc. ● Do not touch the terminal block or any of the various setting switches in the power ON mode. Failure to do so may result in an electric shock or malfunction.
7	Automatic Operation	<ul style="list-style-type: none"> ● Check before starting the automatic operation or rebooting after operation stop that there is nobody in the safety protection fence. ● Before starting automatic operation, make sure that all peripheral equipment is in an automatic-operation-ready state and there is no alarm indication. ● Make sure to operate automatic operation start from outside of the safety protection fence. ● In the case that there is any abnormal heating, smoke, offensive smell, or abnormal noise in the product, immediately stop the machine and turn OFF the power switch. Failure to do so may result in a fire or damage to the product. ● When a power failure occurs, turn OFF the power switch. Failure to do so may cause an injury or damage to the product, due to a sudden motion of the product in the recovery operation from the power failure.

No.	Operation Description	Description
8	Maintenance and Inspection	<ul style="list-style-type: none"> ● When the work is carried out with 2 or more persons, make it clear who is to be the “leader” and who to be the “follower(s)” and communicate well with each other to ensure the safety of the workers. ● Perform the work out of the safety protection fence, if possible. In the case that the operation is to be performed unavoidably inside the safety protection fence, prepare the “Stipulations for the Operation” and make sure that all the workers acknowledge and understand them well. ● When the work is to be performed inside the safety protection fence, basically turn OFF the power switch. ● When the operation is to be performed inside the safety protection fence, the worker should have an emergency stop switch at hand with him so that the unit can be stopped any time in an emergency. ● When the operation is to be performed inside the safety protection fence, in addition to the workers, arrange a watchman so that the machine can be stopped any time in an emergency. Also, keep watch on the operation so that any third person can not operate the switches carelessly. ● Place a sign “Under Operation” at the position easy to see. ● For the grease for the guide or ball screw, use appropriate grease according to the instruction manual for each model. ● Do not perform the dielectric strength test. Failure to do so may result in a damage to the product. ● When releasing the brake on a vertically oriented actuator, exercise precaution not to pinch your hand or damage the work parts with the actuator dropped by gravity. ● The slider or rod may get misaligned OFF the stop position if the servo is turned OFF. Be careful not to get injured or damaged due to an unnecessary operation. ● Pay attention not to lose the removed cover or screws, and make sure to put the product back to the original condition after maintenance and inspection works. <p>Use in incomplete condition may cause damage to the product or an injury.</p> <p>* Safety protection Fence : In the case that there is no safety protection fence, the movable range should be indicated.</p>
9	Modification and Dismantle	<ul style="list-style-type: none"> ● Do not modify, disassemble, assemble or use of maintenance parts not specified based at your own discretion.
10	Disposal	<ul style="list-style-type: none"> ● When the product becomes no longer usable or necessary, dispose of it properly as an industrial waste. ● When removing the actuator for disposal, pay attention to drop of components when detaching screws. ● Do not put the product in a fire when disposing of it. The product may burst or generate toxic gases.
11	Other	<ul style="list-style-type: none"> ● Do not come close to the product or the harnesses if you are a person who requires a support of medical devices such as a pacemaker. Doing so may affect the performance of your medical device. ● See Overseas Specifications Compliance Manual to check whether complies if necessary. ● For the handling of actuators and controllers, follow the dedicated instruction manual of each unit to ensure the safety. ● Using the devise in a way not indicated by IAI may lose the protection performance equipped to the device.

Alert Indication

The safety precautions are divided into “Danger”, “Warning”, “Caution” and “Notice” according to the warning level, as follows, and described in the instruction manual for each model.

Level	Degree of Danger and Damage	Symbol
Danger	This indicates an imminently hazardous situation which, if the product is not handled correctly, will result in death or serious injury.	 Danger
Warning	This indicates a potentially hazardous situation which, if the product is not handled correctly, could result in death or serious injury.	 Warning
Caution	This indicates a potentially hazardous situation which, if the product is not handled correctly, may result in minor injury or property damage.	 Caution
Notice	This indicates lower possibility for the injury, but should be kept to use this product properly.	 Notice

Caution in Handling

1. Make sure to follow the usage condition, environment and specification range of the product.
In case it is not secured, it may cause a drop in performance or malfunction of the product.
2. Do not conduct any treatment or operation that is not stated in this instruction manual.
3. It is recommended to apply our products for the wiring between the actuator and the controller.
4. Do not attempt to establish the settings for the speed and acceleration/deceleration above the maximum specification.
An operation with speed and acceleration/deceleration beyond the allowable range may cause an abnormal noise, vibration, malfunction or shortened life.
In the case of interpolated operation of combined axes, the speed and acceleration/deceleration settings should correspond to the minimum values among all combined axes.
5. Set the allowable moment within the allowable range.
If the robot is operated under a load equal to or greater than the allowable moment, abnormal noise or vibration, failure, or shorter life may result.
If it is extreme, flaking may occur on the guide.
6. When the work piece removal is required at the power OFF, do not attempt to pull off the work piece forcefully to remove it.
Remove the work piece either by twisting or detaching one of the finger attachments. Pulling off the work piece forcefully may cause damage to the product.
[Refer to 4.2, "Release of the Gripped Work Piece"]
7. Remove the gripped work piece when the device will not be used for a long time.
Leaving the product with a work piece being held for a long term may drop the performance or give a bad impact to the guide.
8. The temperature on the body may get very high during operation.



Caution: Be careful not to get burnt when touching the actuator.

9. Make sure to attach the actuator properly by following this instruction manual.
Using the product with the actuator not being certainly retained or affixed may cause abnormal noise, vibration, malfunction or shorten the product life.

10. In case of removing the grease applied on the fingers and finger guides after delivery, make sure to implement a rust prevention treatment.

There is grease applied on the fingers and finger guides at the delivery for rust prevention treatment.

The fingers and finger guides may gather rust if the grease is wiped away.

Also, have grease or an anti-rust agent applied on the fingers and finger guides regularly.

[Refer to 5.4 Grease Supply]

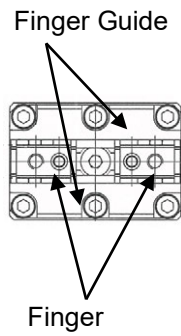

International Standards Compliances

This actuator complies with overseas standards marked with ○ .
Refer to [Overseas Standard Compliance Manual (ME0287)] for more detailed information.

RoHS3 Directive	CE Marking	UL Certification
○	○	×

Names of the Parts

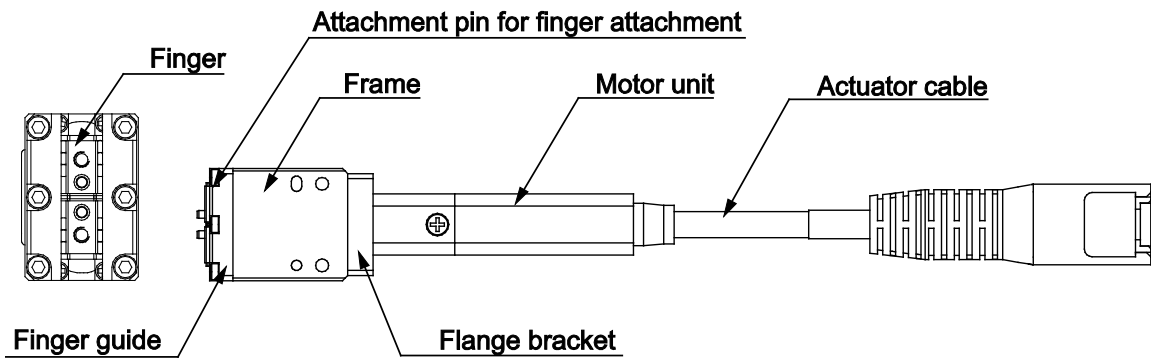

1. Specifications Check

1.1 Checking the Product

The standard configuration of this product is comprised of the following parts. See the component list for the details of the enclosed components. If you find any fault or missing parts, contact your local IAI distributor.

1.1.1 Parts

No.	Name	Model number	Quantity	Remarks
1	Actuator	Refer to "How to Read the Model Nameplate" and "How to Read the Model Number."	1	
Accessories				
2	Motor • Encoder Cables (Note1)		1	
3	Safety Guide		1	

Note1 The motor • encoder cables differ between the standard model and robot cable.
[Refer to 1.5, "Motor • Encoder Cables."]

1.1.2 Instruction Manuals for the Controllers Related to this Product

No.	Name	Control No.
1	Instruction Manual for ASEP/PSEP/DSEP Controller	ME0267
2	Instruction Manual for ACON-CA/DCON-CA	ME0326
3	Instruction Manual for PC Software RCM-101-MW/RCM-101-USB	ME0155
4	Instruction Manual for Touch Panel Teaching Pendant CON-PTA/PDA/PGA	ME0295
5	Instruction Manual for Touch Panel Teaching Pendant CON-PT/PD/PG	ME0227
6	Instruction Manual for Touch Panel Teaching Pendant TB-01/01D/01DR (Applicable for Position Controller)	ME0324

1.1.3 How to Read the Model Nameplate

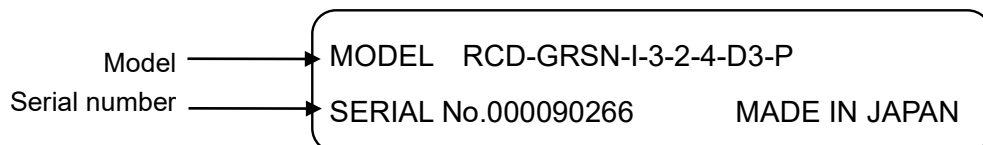

1.1.4 How to Read the Model Number

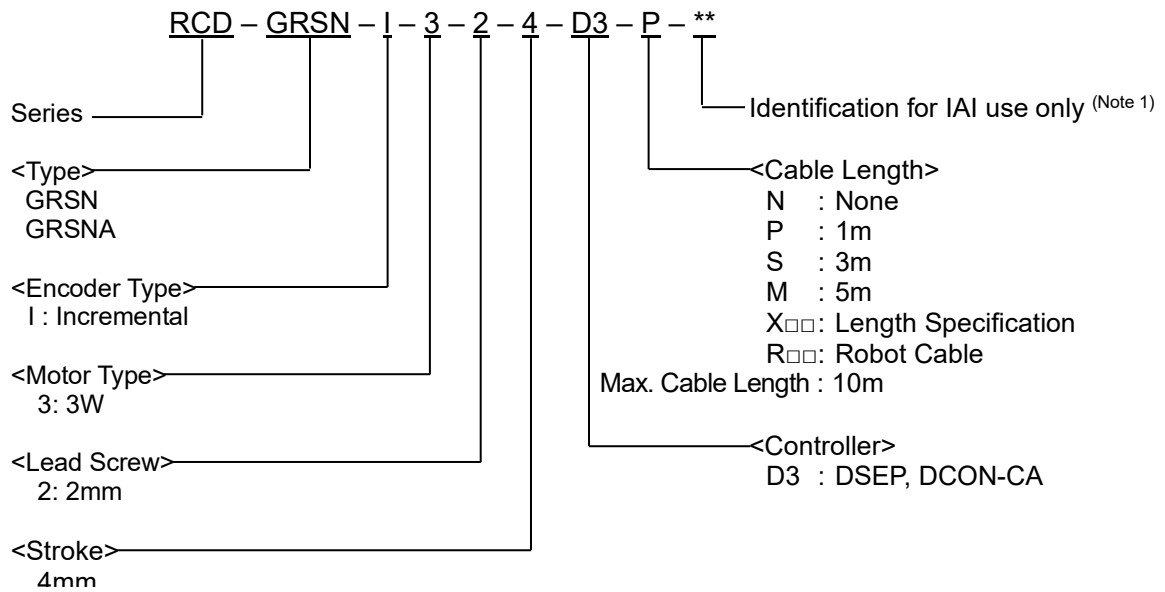

Note 1 Identification for IAI use only : It may be displayed for IAI use. It is not a code to show the model type.

1.2 Specifications

1.2.1 Common

Performance	GRSN	GRSNA
Motor output [W]	3	
Open/Close Stroke [mm]	4 (One side 2)	
Allowable Vertical Load [N]	14	
Max. Open/Close Speed ^(Note 1) [mm/s]	67	
Maximum Acceleration [G]	1.0	
Maximum Thrust (finger on one side) [N(kgf)]	7.1 (0.7)	
Positioning repeatability [mm]	±0.05	
Backlash of Finger on One Side [mm]	0.4 or less	
Lost Motion [mm]	0.5 or less	
No. of Encoder Pulses	400	480
Conversion between linear move and gripping move	Grooved cam type (gear ratio 1: 3.7)	
Pollution Degree	Class 2	

Note1 The maximum speed may not be reached depending on the operational stroke and the acceleration/deceleration setting.

1.2.2 Relation between the Current Limit Value and the Grip Force

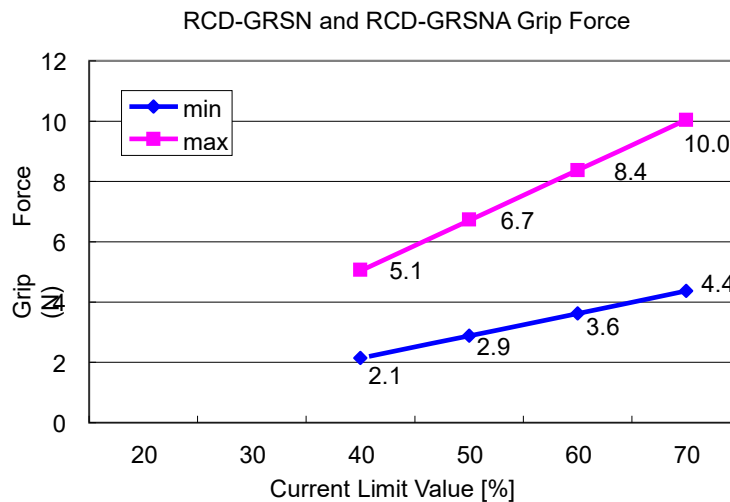

Caution:

- (1) It is a reference when assuming the speed is 5mm/s.
- (2) The grip force is the values under the conditions stated below.
The total value of the grip force of both slides at the top surface of the slides (gripping point = 0mm, overhang = 0mm)

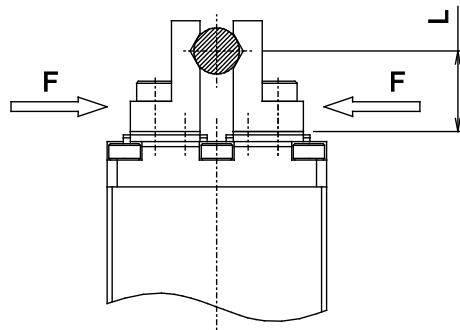

- (3) Use the product within the range in the graph for the current limit value. The pressing force will not be stable if used below 40%. There is even a case that it would not operate. The product cannot be used above 70%. Doing so may cause degradation in the motor coil insulation by heat radiation, which results in shortening the product life.
- (4) When the approach speed to the pressing start position (setting in the position table) is 5mm/s or less, pressing will be performed with the approach speed. In such a case the pressing force will also be unstable. In such cases, check in advance that the actuator can be used with no problem before using.

1.2.3 Allowable Static Moments

Allowable Static Moment [N·m]			Max. Gripping Point (L) [mm]	Max. Overhang (H) [mm]
Ma	Mb	Mc		
0.04	0.04	0.07	20	20

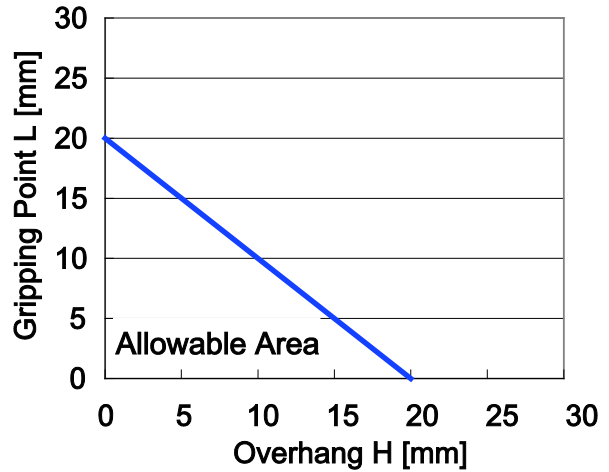
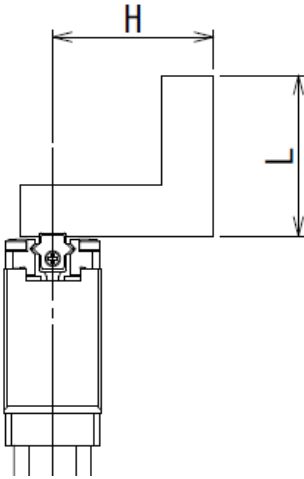

⚠ Caution: Use the product within the allowable area shown in the graph above for the maximum gripping point (L) and maximum overhang amount (H). Use of the product outside the range may drop the life of the guide drastically.

1.2.4 Duty in Continuous Operation

Continuous operation is available with the duty 100%.

Duty is the rate of operation expressed in % that represents the time of the actuator being operated in 1 cycle of operation.

1.3 Operating Conditions

1.3.1 Grip Force

It is necessary to satisfy the conditions stated below to use the product. Conduct the following calculation to make sure it is satisfied.

Procedure 1 : Check for the necessary grip force and transportable work piece mass



Procedure 2 : Check for the vertical allowable load of the fingers and allowable moment

Procedure 1 : Check for the necessary grip force and transportable work piece mass

If a work piece is to be gripped on the fingers with the friction force created by the grip force, the formula to calculate the necessary grip force is as follows;

(1) In case of ordinary transportation

- F : Grip Force [N].....Sum of pressing force on each finger
- μ : Coefficient of static friction between finger attachment and work piece
- m : Mass of work piece [kg]
- g : Gravitational acceleration [= 9.8m/s²]

The condition to grip the work piece statically and that the work piece would not drop is;

$$F\mu > W$$

$$F > \frac{mg}{\mu}$$

The necessary grip force assuming the safety factor recommended for ordinary transportation is 2 should be;

$$F > \frac{mg}{\mu} \times 2 \text{ (safety factor)}$$

When coefficient of friction is μ 0.1 to 0.2;

$$F > \frac{mg}{0.1 \text{ to } 0.2} \times 2 = (10 \text{ to } 20) \times mg$$

* The mass of a transportable work piece will get higher as the coefficient of static friction is higher. However it is necessary to that enables it to obtain a grip force of 10 to 20 times or more to ensure the safety.

For ordinary work piece transportation;
 Necessary grip force \Rightarrow 10 to 20 times or more of work piece mass
 Transportable work piece mass \Rightarrow 1/10 to 1/20 or less of grip force

(2) In case of high acceleration/deceleration speed or a big impact is applied to the work piece during transportation

High inertial force, in addition to the gravity, will be applied to the work piece. In such cases, consider an even higher safety factor if it is necessary.

When high acceleration/deceleration speed or a big impact is applied;
 Necessary grip force \Rightarrow 30 to 50 times or more of the work piece mass
 Transportable work piece mass \Rightarrow 1/30 to 1/50 or less of the grip force

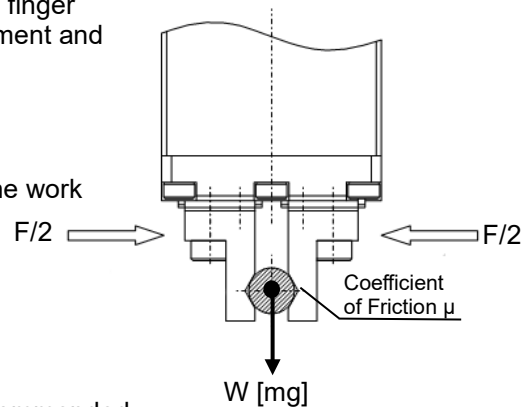

Procedure 2 : Check for the vertical allowable load of the fingers and allowable moment
 Check the vertical load and the moment applicable to the finger. Figure out F_z , M_a , M_b and M_c by referring to (1) to (3) described below, and it is necessary to select a suitable model considering not to exceed the allowable values.

Load and the moment applicable to the finger

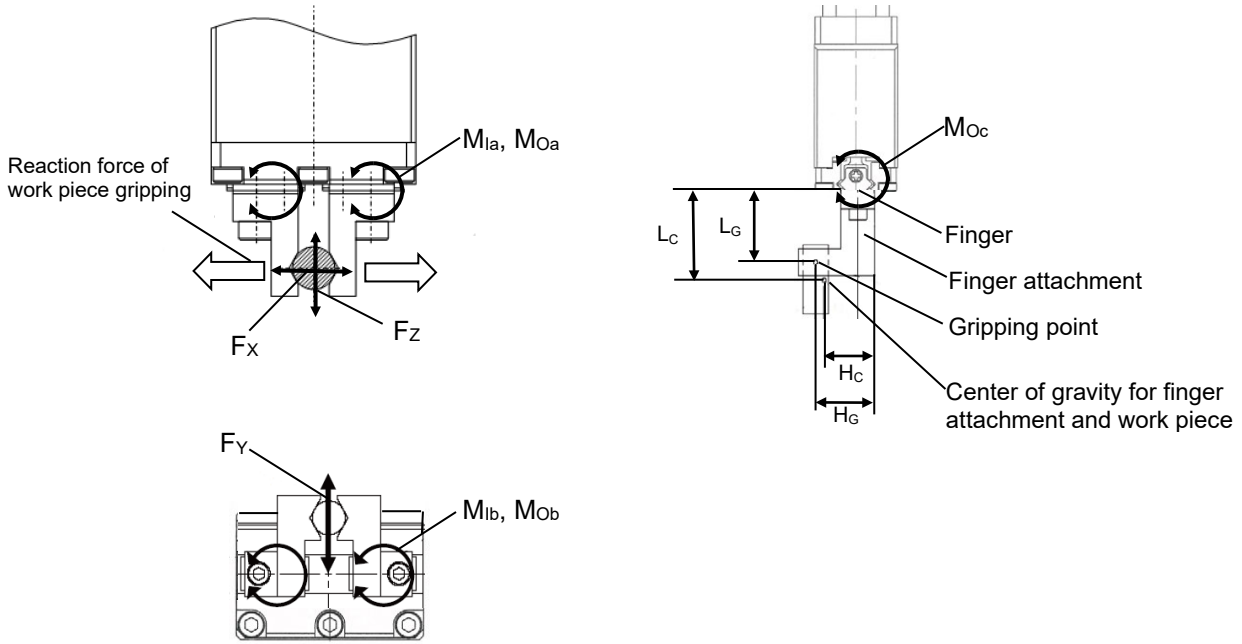

- F_x : External force in X direction applied to work piece and finger [N]
- F_y : External force in Y direction applied to work piece and finger [N]
- F_z : External force in Z direction applied to work piece and finger [N]
- L_g : Distance from finger attachment surface to gripping point [mm] ^(Note 1)
- H_g : Distance from center of fingers to gripping point (Overhang) [mm] ^(Note 1)
- L_c : Distance from finger attachment surface to center of gravity for work piece and finger attachment [mm]
- H_c : Distance from center of fingers to center of gravity for work piece and finger attachment [mm]
- M_{la} : Moment in M_a direction generated on fingers due to grip force [N·m]
- M_{lb} : Moment in M_b direction generated on fingers due to grip force [N·m]
- M_{Oa} : Moment in M_a direction generated on fingers due to external force [N·m]
- M_{Ob} : Moment in M_b direction generated on fingers due to external force [N·m]
- M_{Oc} : Moment in M_c direction generated on fingers due to external force [N·m]
- M_a : All moments in M_a direction generated on fingers [N·m]
- M_b : All moments in M_b direction generated on fingers [N·m]
- M_c : All moments in M_c direction generated on fingers [N·m]

Note 1 For L_g and H_g , have the values below as the upper limit. Exceeding the allowable range may generate an excessive moment on the finger sliding mechanism, which may be a cause of a bad impact to the product life.

Upper Limit for Gripping Point L_g and Overhang H_g

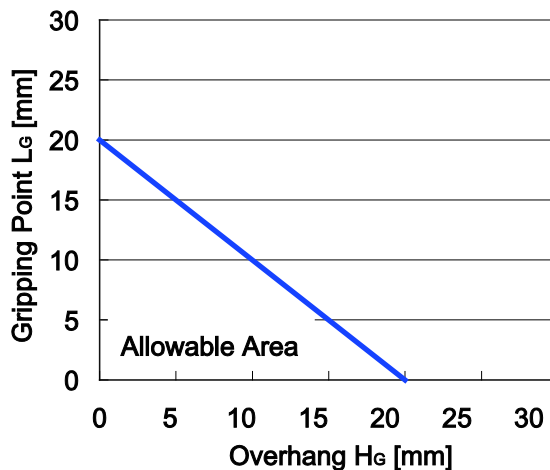

Table 1: Allowable Load and Allowable Moment on the Fingers (Note 1)

Allowable Load in Vertical [N] F_{Zmax}	Max. Allowable moment [N·m] (Note 2)		
	M_{amax}	M_{bmax}	M_{cmax}
14	0.04	0.04	0.07

Note 1 The graphs show the values for allowable load and allowable moment in static on one finger.

Note 2 The values for the allowable moment are those when the load is applied in one direction only.

The values become one half when the load is applied from two directions.

(1) Moment generated on fingers due to grip force

1) Moment in Ma direction [M_{la}]

$$M_{la} = L_G \frac{1.5F_G}{2} \times 10^{-3}$$

F_G: Grip force of gripper [N]

2) Moment in Mb direction [M_{lb}]

$$M_{lb} = H_G \frac{1.5F_G}{2} \times 10^{-3}$$

F_G: Grip force of gripper [N]

Refer to "1.2.2 Relation between Current Limit Value and Grip Force" for grip force F_G.

As the grip force is a reference value, it is multiplied by 1.5 for the safety margin in the moment calculation.

(2) Moment generated on the fingers due to an external force

External force as well as grip force will be applied to the work piece and the finger attachment in the movements such as moving straight or turning in the condition of the gripper being attached on a Cartesian Robot, Articulated Robot or other actuators.

Have the following calculation.

◆ External force applied on the work piece and finger attachment [F_x, F_y, F_z]

Figure out the following types of external forces in three directions, X, Y and Z, applied on the work piece and finger attachment considering the condition of the gripper use, and sum up all the values to determine F_x, F_y and F_z.

a) Weight of the work piece and finger attachment

$$F = mg \quad m : \text{mass of the work piece and finger attachment [kg],}$$

$$g : \text{gravitational acceleration [=9.8m/s}^2\text{]}$$

b) Inertial force in the gripper moving straight

$$F = ma \quad a : \text{Acceleration/deceleration during transportation [m/s}^2\text{]}$$

c) Centrifugal force in gripper turning

$$F = mr \omega^2 \quad r : \text{Radius of turning [m], } \omega : \text{Angular velocity [deg/s]}$$

Confirm that F_z is below the allowable load vertical direction, F_{zmax} in Table 1.

◆ Moment generated on the fingers due to an external force

Figure out the moment in each direction due to external forces F_x, F_y and F_z calculated above.

1) Moment in Ma direction [M_{oa}]

$$M_{oa} = L_c F_x \times 10^{-3}$$

2) Moment in Mb direction [M_{ob}]

$$M_{ob} = H_c F_x \times 10^{-3}$$

3) Moment in Mc direction [M_{oc}]

$$M_{oc} = L_c F_y \times 10^{-3} + H_c F_z \times 10^{-3}$$

(3) All moments in each direction generated to the fingers

$$M_a = M_{la} + M_{oa}, \quad M_b = M_{lb} + M_{ob}, \quad M_c = M_{oc}$$

Confirm that the value figured out in the calculation above is below the allowable moment stated in Table 1.

(Note) Attempt to have the finger attachment minimized in size and weight even if it is in the allowable range. If the fingers are long and big in size and heavy in mass, the moment caused by an impact at gripping may cause a performance drop or give a bad impact to the guide area.

1.4 Motor • Encoder Cables

1.4.1 Motor • Encoder Integrated Cable Connection

CB-CAN-MPA□□□ (□□□ indicates the cable length L Example: 020 = 2m), up to 10m

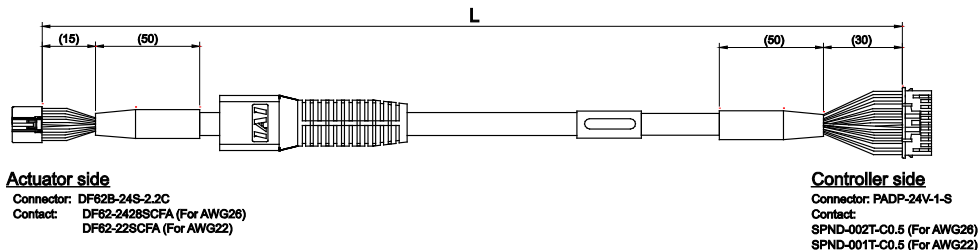

Connection diagram

Actuator side

Controller side

Thickness	Electric Wire Color	Symbol	Pin No.		Pin No.	Symbol	Electric Wire Color	Thickness
AWG22/19	Blue	U	3		1	U	Blue	AWG22/19
AWG22/19	Orange	V	5		2	V	Orange	AWG22/19
AWG22/19	Brown	-	10		3	-	Brown	AWG22/19
AWG22/19	Gray	-	9		4	-	Gray	AWG22/19
AWG22/19	Green	W	4		5	W	Green	AWG22/19
AWG22/19	Red	-	15		6	-	Red	AWG22/19
AWG26	Black	-	8		7	-	Black	AWG26
AWG26	Yellow	-	14		8	-	Yellow	AWG26
AWG26	Blue	A+	12		11	A+	Blue	AWG26
AWG26	Orange	A-	17		12	A-	Orange	AWG26
AWG26	Green	B+	1		13	B+	Green	AWG26
AWG26	Brown	B-	6		14	B-	Brown	AWG26
AWG26	Gray	HS1_IN	11		15	HS1_IN	Gray	AWG26
AWG26	Red	HS2_IN	16		16	HS2_IN	Red	AWG26
AWG26	Blue	-	20		9	-	Blue	AWG26
AWG26	Orange	-	2		10	-	Orange	AWG26
AWG26	Gray	VCC	21		17	VCC	Gray	AWG26
AWG26	Red	GND	7		19	GND	Red	AWG26
AWG26	Brown	-	18		18	-	Brown	AWG26
AWG26	Green	HS3_IN	13		20	HS3_IN	Green	AWG26
-	-	-	19		22	-	-	-
AWG26	Pink	-	22		21	-	Pink	AWG26
-	-	-	23		23	-	-	-
AWG26	Black	FG	24		24	FG	Black	AWG26

(Note) About thickness AWG22/19
 The thickness is AWG22 when the cable length is 5m or less, and AWG19 when longer than 5m.

1.4.2 Motor • Encoder Integrated Cables Robot Type

CB-CAN-MPA□□□-RB (□□□ indicates the cable length L Example: 020 = 2m), up to 10m

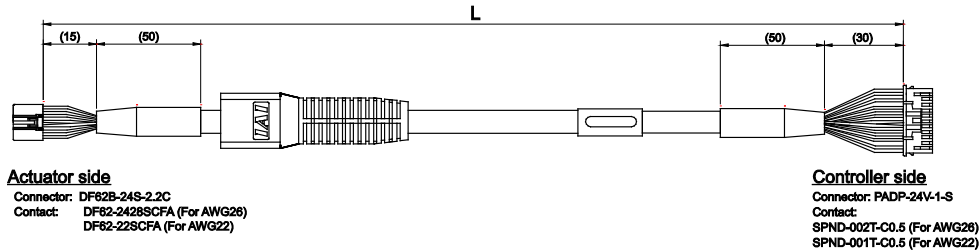

1. Specifications Check

Connection diagram

Actuator side

Controller side

Thickness	Electric Wire Color	Symbol	Pin No.		Pin No.	Symbol	Electric Wire Color	Thickness
AWG22/19	Blue	U	3		1	U	Blue	AWG22/19
AWG22/19	Orange	V	5		2	V	Orange	AWG22/19
AWG22/19	Brown	-	10		3	-	Brown	AWG22/19
AWG22/19	Gray	-	9		4	-	Gray	AWG22/19
AWG22/19	Green	W	4		5	W	Green	AWG22/19
AWG22/19	Red	-	15		6	-	Red	AWG22/19
AWG26	Black	-	8		7	-	Black	AWG26
AWG26	Yellow	-	14		8	-	Yellow	AWG26
AWG26	Blue	A+	12		11	A+	Blue	AWG26
AWG26	Orange	A-	17		12	A-	Orange	AWG26
AWG26	Green	B+	1		13	B+	Green	AWG26
AWG26	Brown	B-	6		14	B-	Brown	AWG26
AWG26	Gray	HS1_IN	11		15	HS1_IN	Gray	AWG26
AWG26	Red	HS2_IN	16		16	HS2_IN	Red	AWG26
AWG26	Blue	-	20		9	-	Blue	AWG26
AWG26	Orange	-	2		10	-	Orange	AWG26
AWG26	Gray	VCC	21		17	VCC	Gray	AWG26
AWG26	Red	GND	7		19	GND	Red	AWG26
AWG26	Brown	-	18		18	-	Brown	AWG26
AWG26	Green	HS3_IN	13		20	HS3_IN	Green	AWG26
-	-	-	19		22	-	-	-
AWG26	Pink	-	22		21	-	Pink	AWG26
-	-	-	23		23	-	-	-
AWG26	Black	FG	24		24	FG	Black	AWG26

(Note) About thickness AWG22/19

The thickness is AWG22 when the cable length is 5m or less, and AWG19 when longer than 5m.

2. Installation

2.1 Transportation

[1] Handling of the Actuator

Unless otherwise specified, the actuator is shipped with each axis unit packaged separately.

(1) Handling the Packed Unit

- Do not damage or drop. The package is not applied with any special treatment that enables it to resist an impact caused by a drop or crash.
- Transport a heavy package with at least more than two operators. Consider an appropriate method for transportation.
- Keep the unit in a horizontal orientation when placing it on the ground or transporting. Follow the instruction if there is any for the packaging condition.
- Do not step or sit on the package.
- Do not put any load that may cause a deformation or breakage of the package.

(2) Handling the Actuator After Unpacking

- Do not carry the actuator by its motor unit or its cable or attempt to move it by pulling the cable.
- Hold the frame section of the body when transporting the actuator main body.
- Do not hit or drop the actuator during transportation.
- Do not attempt to force any part of the actuator. Do not apply excess force especially on the fingers, finger guide and levers.

[2] Handling in the Assembled Condition

This is the case when the product is delivered from our factory under a condition that it is assembled with other actuators. The combined axes are delivered in a package that the frame is nailed on the lumber base.

(1) How to Handle the Package

- Do not hit or drop the package. No special treatment is conducted on this package to endure a drop or impact on it.
- Do not attempt to carry a heavy package with only one worker. Also, have an appropriate method for transportation.
- When hanging up with ropes, support on the reinforcement frame on the bottom of the lumber base. When bringing up the package with a forklift, also support on the bottom of the lumber base.
- Handle with care when putting the package down to avoid impact or bounce.
- Do not step on the package.
- Do not put anything on the package that could deform or damage it.

(2) How to Handle after Unpackaged

- Fix the finger so they would not accidentally move during transportation.
- If the tip of an actuator is overhanging, have an appropriate way to fix it to avoid shake due to the external vibration. In the transportation without the tip being fixed, do not apply any impact with 0.3G or more.
- When hanging up with ropes, have appropriate cushioning to avoid any deformation of the actuator body. Also keep it in stable horizontal orientation. Make a fixture utilizing the attachment holes and the tapped holes on the actuator body if necessary.
- Do not attempt to apply load on the actuators or the connector box. Also pay attention not to pinch cables and bend or deform them forcefully.

[3] Handling in Condition of being assembled in Machinery Equipment (System)

These are some caution notes for when transporting the actuator being assembled in the machinery equipment (system):

- Fix the actuator so it would not move during transportation.
- If the tip of an actuator is overhanging, have an appropriate way to fix it to avoid shake due to the external vibration. In the transportation without the tip being fixed, do not apply any impact with 0.3G or more.
- When hanging up the machinery equipment (system) with ropes, do not attempt to apply load on the actuators or the connector box. Also pay attention not to pinch cables and bend or deform them forcefully.

2.2 Installation and Storage • Preservation Environment

[1] Installation Environment

The actuator should be installed in a location other than those specified below. Also provide sufficient work space required for maintenance inspection.

- Where the actuator receives radiant heat from strong heat sources such as heat treatment furnaces
- Where the ambient temperature exceeds the range of 0 to 40°C
- Where the temperature changes rapidly and condensation occurs
- Where relative humidity smaller than 10% or larger than 85%RH
- Where the actuator receives direct sunlight
- Where the actuator is exposed to corrosive or combustible gases
- Where the ambient air contains a large amount of powder dust, salt or iron (at level exceeding what is normally expected in an assembly plant)
- Where the actuator is subject to splashed water, oil (including oil mist or cutting fluid) or chemical solutions
- Where the actuator receives impact or vibration
- Place with an altitude of 2,000m or more

If the actuator is used in any of the following locations, provide sufficient shielding measures:

- Where noise generates due to static electricity, etc.
- Where the actuator is subject to a strong electric or magnetic field
- Where the actuator is subject to ultraviolet ray or radiation

[2] Storage • Preservation Environment

- The storage and preservation environment should comply with the same standards as those for the installation environment. In particular, when the machine is to be stored for a long time, pay close attention to environmental conditions so that no dew condensation forms.
- Unless specially specified, moisture absorbency protection is not included in the package when the machine is delivered. In the case that the machine is to be stored and preserved in an environment where dew condensation is anticipated, take the condensation preventive measures from outside of the entire package, or directly after opening the package.
- For storage and preservation temperature, the machine withstands temperatures up to 60°C for a short time, but in the case of the storage and preservation period of 1 month or more, control the temperature to 50°C or less.
- Storage and preservation should be performed in the horizontal condition. In the case it is stored in the packaged condition, follow the posture instruction if any displayed on the package.

2.3 How to Install



This chapter explains how to install the actuator on your mechanical system.

2.3.1 Installation

○ : Possible × : Not possible

Horizontal installation	Vertical installation	Sideways installation	Ceiling Mount installation
○	○	○	○

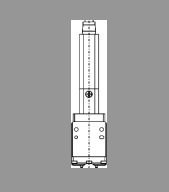
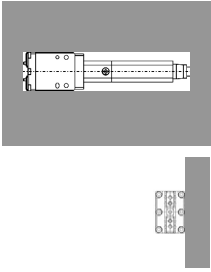
Installation Orientation

Horizontal	Vertical	Sideways	Ceiling Mount
			

2.3.2 Installation of the Main Unit

Make sure that the surface to install the product is a well-finished machined surface or one that possesses an accuracy equivalent to it.

- When fixing the body, use the tapped or through holes (2 places) on the attachment surface. Screws or tapped holes may get damaged depending on the load applied to the body if not all the holes are used.
(For the sizes of the tapped and through holes, refer to the figure below, figures in the next page and after and 6. "External Dimensions".)
- There are a rounded hole and a slotted hole for positioning equipped on each attachment surface. Utilize these holes if necessary.

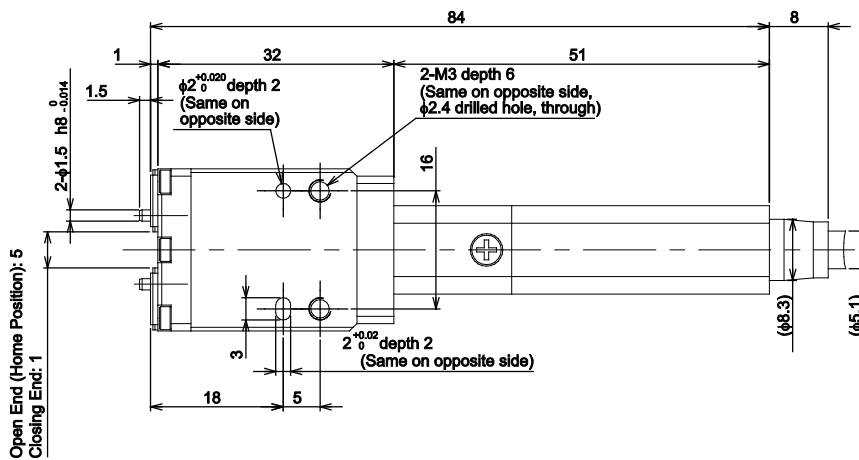
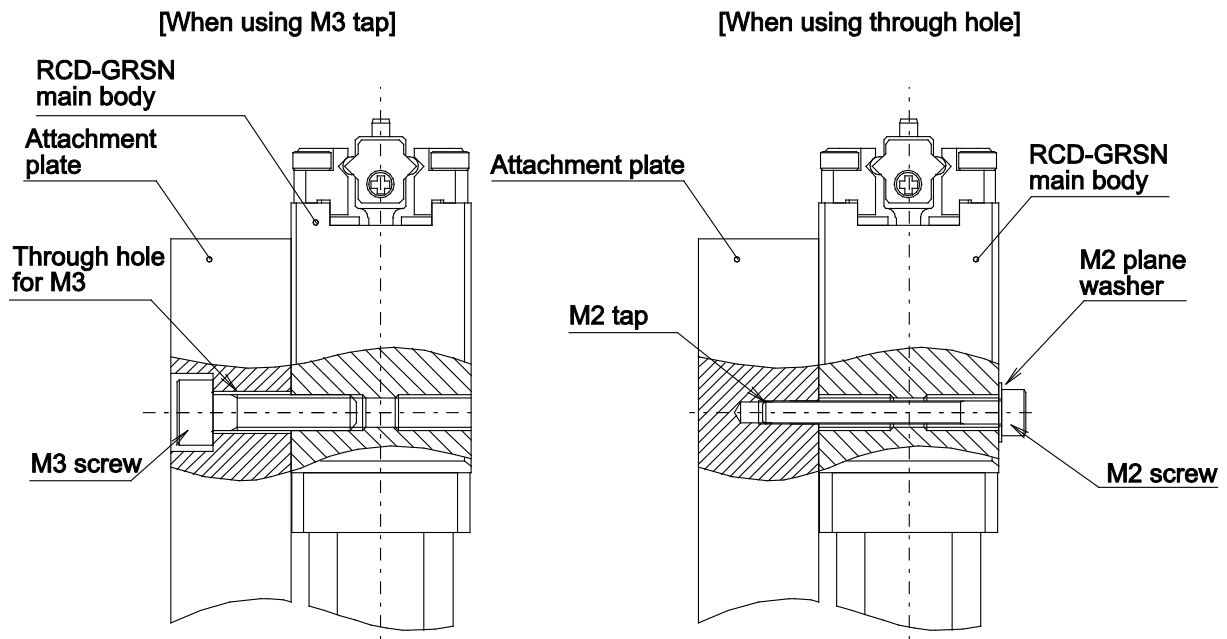

Fixation Method	Nominal thread size	Tightening Torque	
		In the case that steel is used for the screw seating surface [N·m (kgf·m)]	In the case that aluminum is used for the screw seating surface [N·m (kgf·m)]
Tapped Hole	M3	1.54 (0.16)	0.83 (0.09)
Through Hole	M2	0.43 (0.05)	0.25 (0.03)

About Tightening Screws

- Use a hex socket head cap screw for the attachment to the base.
- It is recommended to use high-tensile screws with ISO-10.9 or more.
- Make sure to have the effective length of screw engagement described below or more for the tightening of a screw and a female screw.

When female screw is on steel → Thread length same as nominal diameter

When female screw is on aluminum → Thread length 1.8 times longer than nominal diameter

 **Caution:** Pay special attention when selecting the screw length. In case that an inappropriate length of a screw is applied, it may cause damage on the tapped holes or insufficiency in attachment strength, which may result in a drop in the operation accuracy or an unexpected accident.

2.3.3 How to Attach the Finger Attachment

Please prepare the finger attachment separately.

[1] Positioning of the Finger Attachment in Open/Close and Vertical Directions

For improvement of the accuracy and the repeatability of the attachment, it is recommended to position by attaching at two points, the positioning pin and the outside of the finger, as shown below.

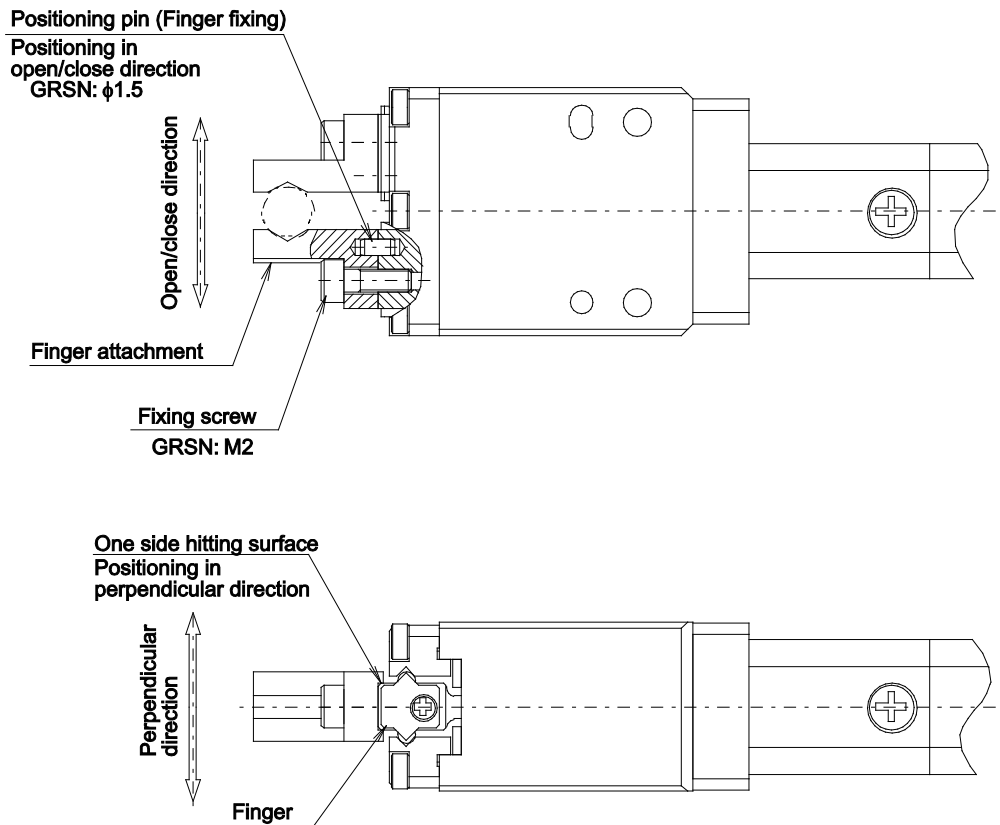
**Caution:**

- When attaching or detaching the finger attachment to the finger, hold the finger attachment with a tool such as a wrench to tighten the attachment screw to avoid load being applied to the guide area.
- The tapped hole and the positioning hole on the finger attachments are through holes. Do not attempt to use a long screw that has a length that is more than the effective thread length. Doing so may damage the internal structure.

[2] Installation Dimensions

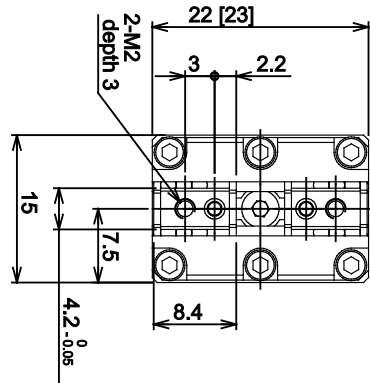

Nominal thread size	Tightening Torque	
	In the case that steel is used for the screw seating surface [N·m (kgf·m)]	In the case that aluminum is used for the screw seating surface [N·m (kgf·m)]
M2	0.43 (0.05)	0.25 (0.03)

About Tightening Screws

- Use a hex socket head cap screw for the attachment to the base.
- It is recommended to use high-tensile screws with ISO-10.9 or more.
- Make sure to have the effective length of screw engagement described below or more for the tightening of a screw and a female screw.

When female screw is on steel → Thread length same as nominal diameter

When female screw is on aluminum → Thread length 1.8 times longer than nominal diameter

⚠ Caution: Pay special attention when selecting the screw length. In case that an inappropriate length of a screw is applied, it may cause damage on the tapped holes or insufficiency in attachment strength, which may result in a drop in the operation accuracy or an unexpected accident.

3. Connecting with the Controller

Use the IAI dedicated connection cable for the connection of the actuator to the controller.

- If the dedicated connection cable cannot be secured, reduce the load on the cable by allowing it to deflect only by the weight of the cable or wire it in a self-standing cable hose, etc., having a large radius.
- Do not cut and reconnect the dedicated connection cable for extension or shorten the cable.
- Do not pull on the dedicated connection cable or bend it forcibly.
- The actuator cable is for fixed use. Fix the cable so it would not be bent repeatedly.

Please consult with IAI if you require a different kind of cable than the one supplied.

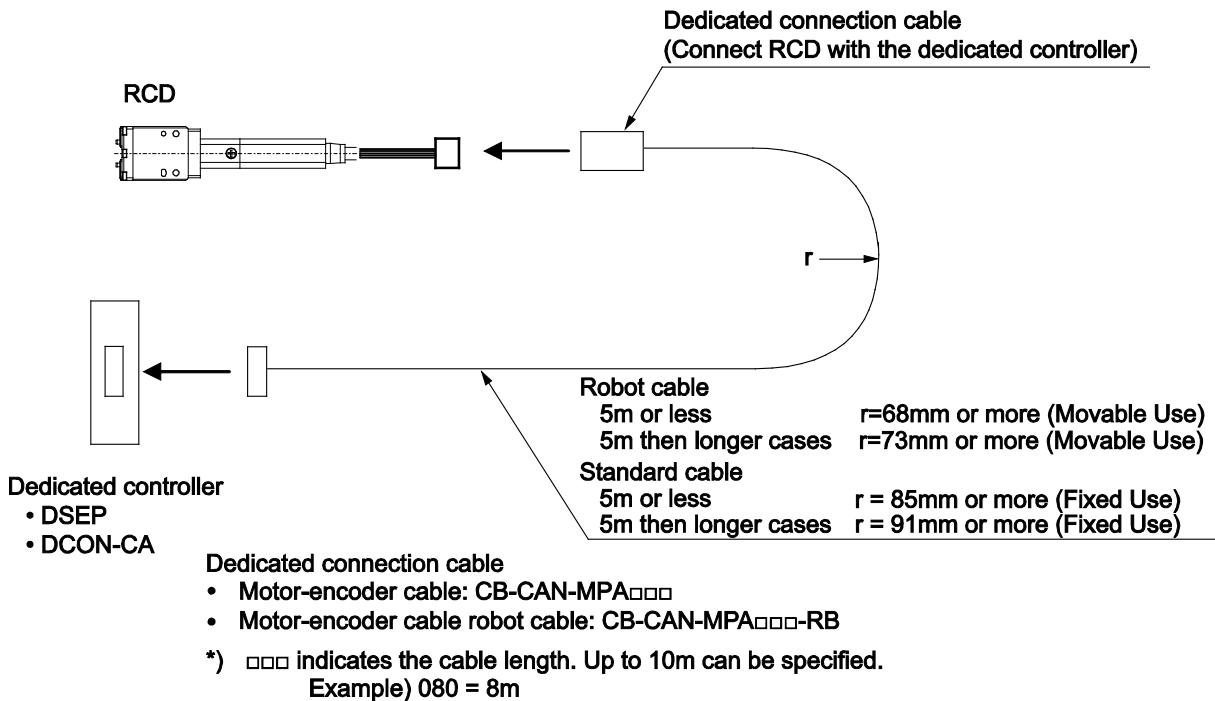

Ensure a space for cable wiring at the back of the motor side on the actuator. Also, make sure the cable out of the actuator is straight.

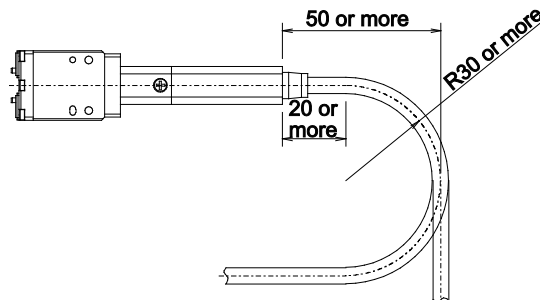



Warning: For wiring, please follow the warnings stated below. When constructing a system as the machinery equipment, pay attention to the wiring and connection of each cable so they are conducted properly. Not following them may cause not only a malfunction such as cable breakage or connection failure, or an operation error, but also electric shock or electric leakage, or may even cause a fire.

- Use dedicated cables of IAI indicated in this instruction manual. Contact us if you wish to have a change to the specifications of the dedicated cables.
- Make sure to turn the power off in the process of power line or cable connection or disconnection.
- Do not attempt to cut a dedicated cable with connectors on both ends to extend, shorten or re-joint it.
- Hold the dedicated cable to avoid mechanical force being applied to the terminals and connectors.
- Use a cable pipe or duct to have an appropriate protection when there is a possibility of mechanical damage on a dedicated cable.
- In case a dedicated cable is to be used at a moving part, make sure to lay out the cable without applying any force to pull the connector or extreme bend on the cable. Do not attempt to use the cable with a bending radius below the allowable value.
- Make certain that the connectors are plugged properly. Insufficient connection may cause an operation error, thus it is extremely risky.
- Do not lay out the cables to where the machine runs over them.
- Pay attention to the cable layout so it would not hit peripherals during an operation. In case it does, have an appropriate protection such as a cable track.
- When a cable is used hanging on the ceiling, prevent an environment that the cable swings with acceleration or wind velocity.
- Make sure there is not too much friction inside the cable storage equipment.
- Do not apply radiated heat to power line or cables.
- Do not bend the cable in the area from the connector tip inward to 150mm on both ends.
 Motor • Encoder Integrated Cables CB-CAN-MPA□□□
 Motor • Encoder Integrated Cables Robot Type CB-CAN-MPA□□□-RB

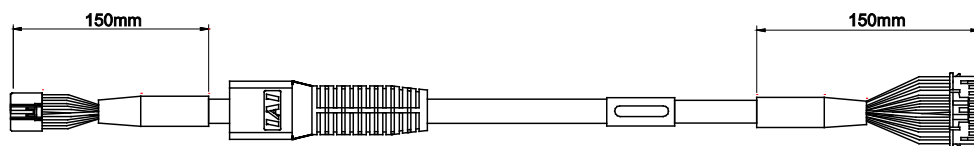

- Have a sufficient radius for bending, and avoid a bend concentrating on one point.

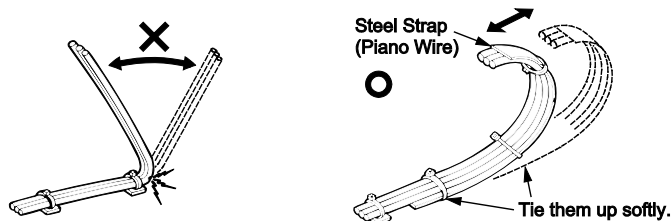

- Do not let the cable bend, kink or twist.

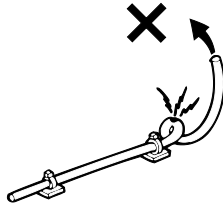

- Do not pull the cable with a strong force.

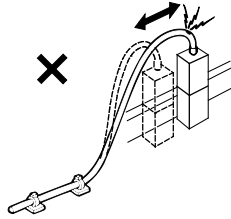

- Pay attention not to concentrate the twisting force to one point on a cable.

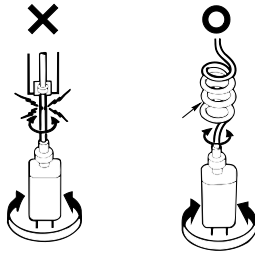

- Do not pinch, drop a heavy object onto or cut the cable.

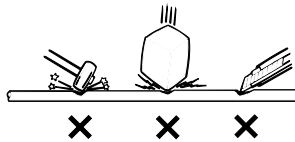

- When a cable is fastened to affix, make sure to have an appropriate force and do not tighten too much.

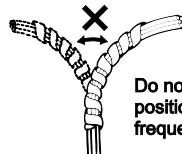
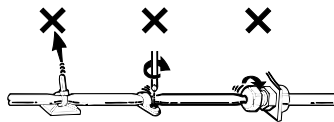

Do not use spiral tube in any position where cables are bent frequently.

- PIO line, communication line, power and driving lines are to be put separately from each other and do not tie them together. Arrange so that such lines are independently routed in the duct.

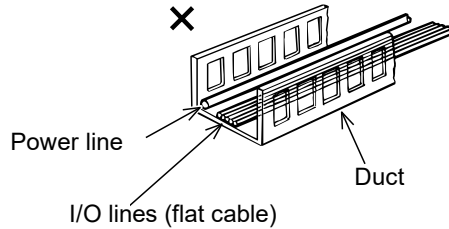

Follow the instructions below when using a cable track.

- If there is an indication to the cable for the space factor in a cable track, refer to the wiring instruction given by the supplier when storing the cable in the cable track.
- Avoid the cables to get twined or twisted in the cable track, and also to have the cables move freely and do not tie them up. (Avoid tension being applied when the cables are bent.)

Do not pile up cables. It may cause faster abrasion of the sheaths or cable breakage.

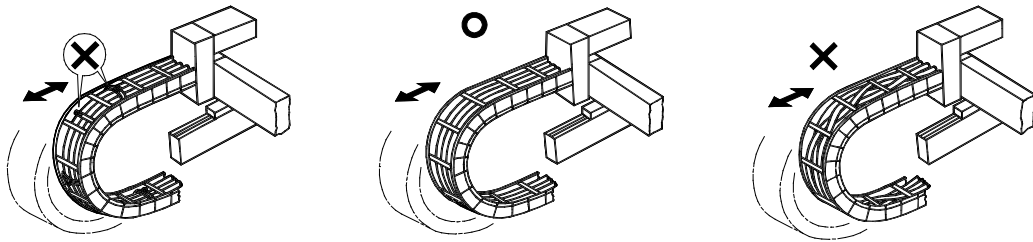

4. Operation

4.1 Operation of the Fingers

[1] Movement Stroke

The stroke stated in the specifications is the sum of the movement distance for both fingers. The movement distance of one finger is 1/2 of the stroke.

[2] Home Return Direction

The open side moving end of the finger is the home position. The home position is on the closing end for the home reversed type (NM).

[3] Position Indication

The movement distance from the home position of one finger to the closing side is the position value.
(Indication of max. position value = 1/2 of stroke)

[4] Indication of Speed and Acceleration

Indication value is the value for one finger.
Relative speed and acceleration are double of the indicated values.

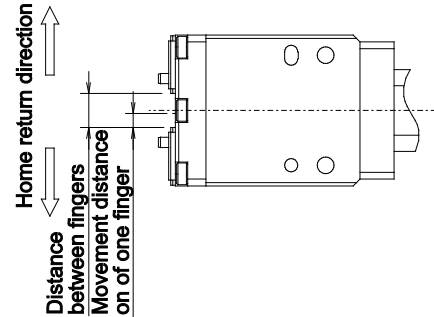

		Slide Type	
		GRSN,	GRSNA
Stroke		4	
Movement Distance of One Side		2	
Distance between Fingers (mm)/(°)	Max.	5	
	Min.	1	

4.2 Release of the Gripped Work Piece

This gripper does not possess a structure to keep the force to grip a work piece (self-lock structure) at the servo-OFF or shutdown of the controller power. However, it is difficult to move a finger freely by applying an external force on it due to the cam structural part. When it is necessary to remove a work piece at the power shutdown, detach the finger attachment on one side to remove the work piece.



Caution:

- When the work piece removal is required at the power OFF, do not attempt to pull off the work piece forcefully to remove it. Remove the work piece either by twisting or detaching one side of the finger attachment.
Pulling off the work piece forcefully may cause damage to the product.
- Remove the gripped work piece when the device would not be used for long time.
Leaving the product with a work piece being held for a long term may drop the performance or give a bad impact to the guide.

5. Maintenance and Inspection

5.1 Inspection Items and Schedule

Perform maintenance and inspection at the intervals specified below.

This schedule assumes that the actuator is operated eight hours a day.

If the actuator is operated at a higher utilization, such as when the machine is used continuously day and night, reduce the inspection intervals accordingly.

	Visual inspection of exterior	Greasing
Start-up inspection	○	
After 1 month of operation	○	
After 3 months of operation	○	
After 6 months of operation	○	○
Every 6 months thereafter	○	○

5.2 Visually Inspecting the Exterior

Visually check the exterior of the following items.

Actuator	Loosening of actuator mounting screws
Cables	Scratches, connector engagement
Overall	Noise, vibration

- If the actuator is installed vertically, certain conditions may cause grease to drip from the guide. Please ensure that proper cleaning is performed and grease is replenished.

5.3 Cleaning

- Clean the exterior surface as necessary.
- Wipe dirty areas using a soft cloth, etc.
- Do not blow highly compressed air onto the actuator, as it may cause dust to enter the actuator through gaps between parts.
- Do not use petroleum-based solvent as it damages resin and coated surfaces.
- To remove stubborn stains, take neutral detergent or alcohol into a soft cloth, etc., and wipe the area gently.

5.4 Grease Supply

5.4.1 Applicable Greases

IAI uses the following grease in our plant.

Guide	Idemitsu Kosan	Daphne Grease MP No. 2
-------	----------------	------------------------

Other companies also sell similar types of grease. For details, give the above grease name to the manufacturer you want to purchase from and ask what corresponding product they have available.

Showa Shell Oil	Albania Grease S2
Mobil Oil	UNIREX N2

 **Warning:** Never use fluorine-based grease. Mixing fluorine-based grease with lithium-based grease not only reduces the performance of the grease, it may even cause damage to the actuator.

5.4.2 How to Apply Grease

- 1) Apply grease by using a spatula between the guide and fingers (steel balls) (where marked with a circle) or apply grease by using a grease injector, and then slide the guide to have the grease spread out evenly.
Wipe away the excess grease and splashed grease at last.
- 2) Spread out the grease evenly on the fingers and finger guides with hand.
(for rust prevention treatment)

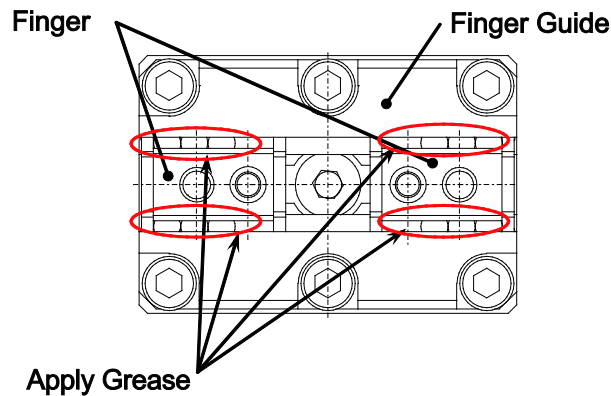

[When using lithium-based spray grease]

WAKO CHEMICAL, LTD.	Spray Grease No. A161 or equivalent
---------------------	-------------------------------------

Shoot the spray grease between the guide and fingers (steel balls). Have the duration of a shot within 1 second. Slide the fingers to have the grease spread out evenly after apply grease.
Wipe away the excess grease and splashed grease at last.



Caution:

- Have the duration of a shot of the spray grease within 1 second, and do not attempt to repeat the supply 2 times or more.
Grease supply more than necessary may cause the grease flow the electrical components, which may cause an error operation.
- In case the grease got into your eye, immediately go to see the doctor to get an appropriate care. After finishing the grease supply work, wash your hands carefully with water and soap to rinse the grease off.

6. External Dimensions

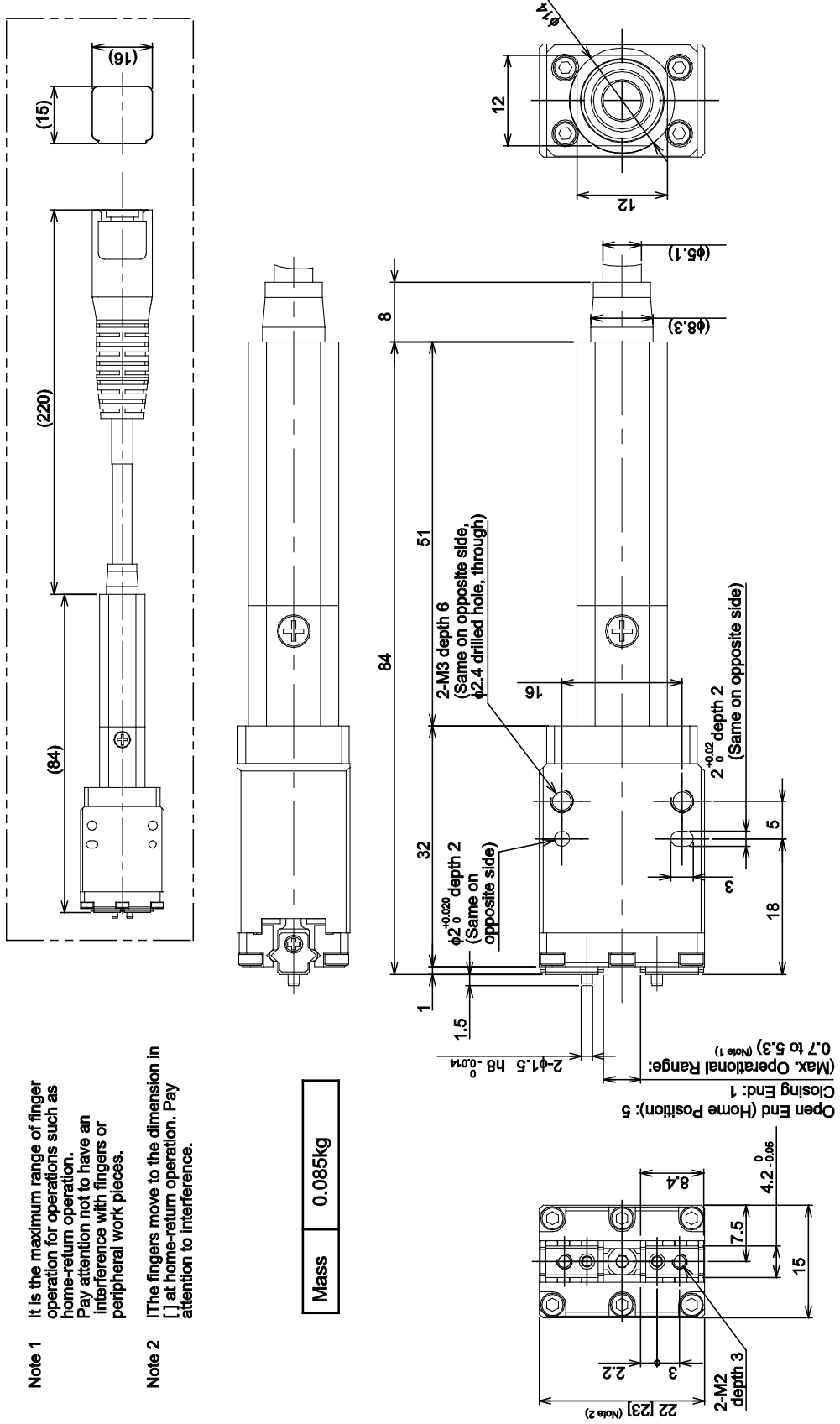

7. Warranty

7.1 Warranty Period

One of the following periods, whichever is shorter:

- 18 months after shipment from IAI
- 12 months after delivery to the specified location
- 2,500 hours of operation

7.2 Scope of the Warranty

Our products are covered by warranty when all of the following conditions are met. Faulty products covered by warranty will be replaced or repaired free of charge:

- (1) The breakdown or problem in question pertains to our product as delivered by us or our authorized dealer.
- (2) The breakdown or problem in question occurred during the warranty period.
- (3) The breakdown or problem in question occurred while the product was in use for an appropriate purpose under the conditions and environment of use specified in the instruction manual and catalog.
- (4) The breakdown of problem in question was caused by a specification defect or problem, or by a quality issue with our product.

Note that breakdowns due to any of the following reasons are excluded from the scope of warranty:

- [1] Anything other than our product
- [2] Modification or repair performed by a party other than us (unless we have approved such modification or repair)
- [3] Anything that could not be easily predicted with the level of science and technology available at the time of shipment from our company
- [4] A natural disaster, man-made disaster, incident or accident for which we are not liable
- [5] Natural fading of paint or other symptoms of aging
- [6] Wear, depletion or other expected result of use
- [7] Operation noise, vibration or other subjective sensation not affecting function or maintenance

Note that the warranty only covers our product as delivered and that any secondary loss arising from a breakdown of our product is excluded from the scope of warranty.

7.3 Honoring the Warranty

As a rule, the product must be brought to us for repair under warranty.

7.4 Limited Liability

- (1) We shall assume no liability for any special damage, consequential loss or passive loss such as a loss of expected profit arising from or in connection with our product.
- (2) We shall not be liable for any program or control method created by the customer to operate our product or for the result of such program or control method.

7.5 Conditions of Conformance with Applicable Standards/Regulations, Etc., and Applications

- (1) If our product is combined with another product or any system, device, etc., used by the customer, the customer must first check the applicable standards, regulations and/or rules. The customer is also responsible for confirming that such combination with our product conforms to the applicable standards, etc. In such a case we will not be liable for the conformance of our product with the applicable standards, etc.
- (2) Our product is for general industrial use. It is not intended or designed for the applications specified below, which require a high level of safety. Accordingly, as a rule our product cannot be used in these applications. Contact us if you must use our product for any of these applications:
 - [1] Medical equipment pertaining to maintenance or management of human life or health
 - [2] A mechanism or mechanical equipment intended to move or transport people (such as a vehicle, railway facility or aviation facility)
 - [3] Important safety parts of mechanical equipment (such as safety devices)
 - [4] Equipment used to handle cultural assets, art or other irreplaceable items
- (3) Contact us at the earliest opportunity if our product is to be used in any condition or environment that differs from what is specified in the catalog or instruction manual.

7.6 Other Items Excluded from Warranty

The price of the product delivered to you does not include expenses associated with programming, the dispatch of engineers, etc. Accordingly, a separate fee will be charged in the following cases even during the warranty period:

- [1] Guidance for installation/adjustment and witnessing of test operation
- [2] Maintenance and inspection
- [3] Technical guidance and education on operating/wiring methods, etc.
- [4] Technical guidance and education on programming and other items related to programs

Change History

Revision Date	Description of Revision
October 2013	First edition
December 2013	Second edition Pg. 12 Changed the model Pg. 20 Deleted the option
January 2014	Third edition Pg. 20 Connection diagram change of the Motor • Encoder Integrated Cables Pg. 21 Motor • Encoder Integrated Cables Robot Type added
May 2014	Fourth edition • GRSNA added • The contents of DCON-CA added
June 2015	Edition 4C Pg. 12 Controller option D5 deleted Pg. 20, 21 CB-CA-MPA□□□ and CB-CA-MPS□□□-RB of cables deleted Pg. 30 Connection diagrams to dedicated connection cables CB-CA-MPA□□□ and CB-CA-MPS□□□-RB deleted Pg. 31 CB-CA-MPA□□□ and CB-CA-MPS□□□-RB deleted Pg. 36 Grease change due to production stop Albania Grease No.2 → Albania Grease S2 Mobilax 2 → UNIREX N2
August 2015	Edition 4D Pg. 9 Note added to notify rust prevention treatment should be implemented in case of removing grease on fingers and finger guides after delivery Pg. 38 Grease supply added for fingers and finger guides
April 2018	Edition 4E Pg. 30 Correction made M3 → M2 Tightening torque, when steel, 1.54 (0.16) → 0.43 (0.05) Tightening torque, when aluminum, 0.83 (0.09) → 0.25 (0.03)
March 2019	Edition 4F Pg. 13, 21, 22, 31 Max. cable length changed from 20m to 10m
August 2019	Edition 4G Pg. 37 Grease changed from Daphne Eponex Grease No. 2 to Daphne Grease MP No. 2
January 2026	Edition 4H • Changes due to discontinuation of including the First Step Guide • Changes due to discontinuation of including the Instruction Manual DVD • International Standards Compliances complied with RoHS3 Directive



IAI Corporation

Head Office: 1210 Ihara Shimizu-KU Shizuoka City Shizuoka 424-0114, Japan
TEL +81-54-364-5105 FAX +81-54-364-2589
website: www.iai-robot.co.jp/

IAI America, Inc.

Head Office: 2690 W. 237th Street, Torrance, CA 90505
TEL +1-310-891-6015 FAX +1-310-891-0815
Chicago Office: 110 East State Parkway, Schaumburg, IL 60173
TEL +1-847-908-1400 FAX +1-847-908-1399
Atlanta Office: 1220 Kennestone Circle, Suite 108, Marietta, GA 30066
TEL +1-678-354-9470 FAX +1-678-354-9471
website: www.intelligentactuator.com

Technical Support available in Europe

IAI Industrieroboter GmbH

Ober der Röth 4, D-65824 Schwalbach am Taunus, Germany
TEL +49(0)6196-88950 FAX +49(0)6196-889524
website: www.iai-automation.com

Technical Support available in Great Britain



Duttons Way, Shadsworth Business Park, Blackburn, Lancashire, BB1 2QR, United Kingdom
TEL +44(0)1254-685900
website: www.lcautomation.com

IAI (Shanghai) Co., Ltd.

SHANGHAI JIAHUA BUSINESS CENTER A8-303, 808, Hongqiao Rd. Shanghai 200030, China
TEL+86-21-6448-4753 FAX +86-21-6448-3992
website: www.iai-robot.com

IAI Robot (Thailand) Co., Ltd.

825 PhairojKijja Tower 7th Floor, Debaratana RD., Bangna-Nuea, Bangna, Bangkok 10260, Thailand
TEL +66-2-361-4458 FAX +66-2-361-4456
website: www.iai-robot.co.th