



**ROBO Cylinder  
ROBO Gripper  
RCS2 Actuator**

**Operation Manual**

**═══════════ Fourth Edition ═══════════**

Two-finger Type , GR8



## **Please Read Before Use**

Thank you for purchasing our product.

This instruction manual explains the handling methods, structure and maintenance of this product, providing the information you need in order to use the product safely.

Before using the product, be sure to read this manual and fully understand the contents explained herein to ensure safe use of the product.

Please download the user's manual from our website.

You can download it free of charge. User registration is required for the first time downloading.

URL : [www.iai-robot.co.jp/data\\_dl/CAD\\_MANUAL/](http://www.iai-robot.co.jp/data_dl/CAD_MANUAL/)

When using the product, print out of the necessary portions of the relevant manual, or please display it on your computer, tablet terminal, etc. so that you can check it immediately.

After reading the instruction manual, keep it in a convenient place so that whoever is handling the product can refer to it quickly when necessary.

### **[Important]**

- This instruction manual is an original document dedicated for this product.
- This product cannot be used in ways not shown in this instruction manual. IAI shall not be liable for any result whatsoever arising from the use of the product in any other way than what is noted in the manual.
- The information contained in this instruction manual is subject to change without notice for the purpose of product improvement.
- If any issues arise regarding the information contained in this instruction manual, contact our customer center or the nearest sales office.
- Use or reproduction of this instruction manual in full or in part without permission is prohibited.
- The company names, names of products and trademarks of each company shown in the text are registered trademarks.

**RC** ROBO CYLINDER

---

---

## Table of Contents

Safety Guide	1
Caution in Handling	8
International Standards Compliances	9
Names of the Parts	10
1. Specifications Check	11
1.1 Checking the Product	11
1.1.1 Parts	11
1.1.2 Operation Manuals for the Controllers Related to this Product	11
1.1.3 How to Read the Model Nameplate	14
1.1.4 How to read the Model Number	14
1.2 Specifications	15
1.2.1 Specifications Table	15
1.2.2 Allowable Load Moment of the Actuator	16
1.3 Motor • Encoder Cables	17
1.3.1 Motor Cable / Motor Robot Cable CB-RCC-MA□□□□ / CB-RCC-MA□□□□-RB	17
1.3.2 Encoder Cable / Encoder Robot Cable CB-RCS2-PA□□□□ / CB-RCS2-PA□□□□-RB (For SCON, SSEL, XSEL-P/Q) CB-RCBC-PA□□□□ / CB-RCBC-PA□□□□-RB (For XSEL-J/K)	18 19
2. Installation	20
2.1 Transportation	20
2.2 Installation and Storage • Preservation Environment	22
2.3 How to Installation	23
2.3.1 Installation Orientation	23
2.3.2 Installation	24
3. Connecting to the Controller	26
4. Caution for Operation (Finger Operations)	31
5. Maintenance Inspection	32
5.1 Inspection Items and Inspection Schedule	32
5.2 Visual Inspection	32
5.3 Cleaning	32
5.4 Grease supply	33
5.4.1 Applied Grease on Guides	33
6. External Dimensions	34
7. Warranty	35
7.1 Warranty Period	35
7.2 Scope of the Warranty	35
7.3 Honoring the Warranty	35
7.4 Limited Liability	35
7.5 Conditions of Conformance with Applicable Standards/Regulations, Etc., and Applications	36
7.6 Other Items Excluded from Warranty	36
Change History	37

**RC** ROBO  
CYLINDER

---

---

## Safety Guide

“Safety Guide” has been written to use the machine safely and so prevent personal injury or property damage beforehand. Make sure to read it before the operation of this product.

### Safety Precautions for Our Products

The common safety precautions for the use of any of our robots in each operation.

No.	Operation Description	Description
1	Model Selection	<ul style="list-style-type: none"> <li>● This product has not been planned and designed for the application where high level of safety is required, so the guarantee of the protection of human life is impossible. Accordingly, do not use it in any of the following applications.               <ol style="list-style-type: none"> <li>1) Medical equipment used to maintain, control or otherwise affect human life or physical health.</li> <li>2) Mechanisms and machinery designed for the purpose of moving or transporting people (For vehicle, railway facility or air navigation facility)</li> <li>3) Important safety parts of machinery (Safety device, etc.)</li> </ol> </li> <li>● Do not use the product outside the specifications. Failure to do so may considerably shorten the life of the product.</li> <li>● Do not use it in any of the following environments.               <ol style="list-style-type: none"> <li>1) Location where there is any inflammable gas, inflammable object or explosive</li> <li>2) Place with potential exposure to radiation</li> <li>3) Location with the ambient temperature or relative humidity exceeding the specification range</li> <li>4) Location where radiant heat is added from direct sunlight or other large heat source</li> <li>5) Location where condensation occurs due to abrupt temperature changes</li> <li>6) Location where there is any corrosive gas (sulfuric acid or hydrochloric acid)</li> <li>7) Location exposed to significant amount of dust, salt or iron powder</li> <li>8) Location subject to direct vibration or impact</li> </ol> </li> <li>● For an actuator used in vertical orientation, select a model which is equipped with a brake. If selecting a model with no brake, the moving part may drop when the power is turned OFF and may cause an accident such as an injury or damage on the work piece.</li> </ul>

No.	Operation Description	Description
2	Transportation	<ul style="list-style-type: none"> <li>● When carrying a heavy object, do the work with two or more persons or utilize equipment such as crane.</li> <li>● When the work is carried out with 2 or more persons, make it clear who is to be the “leader” and who to be the “follower(s)” and communicate well with each other to ensure the safety of the workers.</li> <li>● When in transportation, consider well about the positions to hold, weight and weight balance and pay special attention to the carried object so it would not get hit or dropped.</li> <li>● Transport it using an appropriate transportation measure. The actuators available for transportation with a crane have eyebolts attached or there are tapped holes to attach bolts. Follow the instructions in the instruction manual for each model.</li> <li>● Do not step or sit on the package.</li> <li>● Do not put any heavy thing that can deform the package, on it.</li> <li>● When using a crane capable of 1t or more of weight, have an operator who has qualifications for crane operation and sling work.</li> <li>● When using a crane or equivalent equipments, make sure not to hang a load that weighs more than the equipment’s capability limit.</li> <li>● Use a hook that is suitable for the load. Consider the safety factor of the hook in such factors as shear strength.</li> <li>● Do not get on the load that is hung on a crane.</li> <li>● Do not leave a load hung up with a crane.</li> <li>● Do not stand under the load that is hung up with a crane.</li> </ul>
3	Storage and Preservation	<ul style="list-style-type: none"> <li>● The storage and preservation environment conforms to the installation environment. However, especially give consideration to the prevention of condensation.</li> <li>● Store the products with a consideration not to fall them over or drop due to an act of God such as earthquake.</li> </ul>
4	Installation and Start	<p>(1) Installation of Robot Main Body and Controller, etc.</p> <ul style="list-style-type: none"> <li>● Make sure to securely hold and fix the product (including the work part). A fall, drop or abnormal motion of the product may cause a damage or injury. Also, be equipped for a fall-over or drop due to an act of God such as earthquake.</li> <li>● Do not get on or put anything on the product. Failure to do so may cause an accidental fall, injury or damage to the product due to a drop of anything, malfunction of the product, performance degradation, or shortening of its life.</li> <li>● When using the product in any of the places specified below, provide a sufficient shield. <ol style="list-style-type: none"> <li>1) Location where electric noise is generated</li> <li>2) Location where high electrical or magnetic field is present</li> <li>3) Location with the mains or power lines passing nearby</li> <li>4) Location where the product may come in contact with water, oil or chemical droplets</li> </ol> </li> </ul>

No.	Operation Description	Description
4	Installation and Start	<p>(2) Cable Wiring</p> <ul style="list-style-type: none"> <li>● Use our company's genuine cables for connecting between the actuator and controller, and for the teaching tool.</li> <li>● Do not scratch on the cable. Do not bend it forcibly. Do not pull it. Do not coil it around. Do not insert it. Do not put any heavy thing on it. Failure to do so may cause a fire, electric shock or malfunction due to leakage or continuity error.</li> <li>● Perform the wiring for the product, after turning OFF the power to the unit, so that there is no wiring error.</li> <li>● When the direct current power (+24V) is connected, take the great care of the directions of positive and negative poles. If the connection direction is not correct, it might cause a fire, product breakdown or malfunction.</li> <li>● Connect the cable connector securely so that there is no disconnection or looseness. Failure to do so may cause a fire, electric shock or malfunction of the product.</li> <li>● Never cut and/or reconnect the cables supplied with the product for the purpose of extending or shortening the cable length. Failure to do so may cause the product to malfunction or cause fire.</li> </ul> <p>(3) Grounding</p> <ul style="list-style-type: none"> <li>● The grounding operation should be performed to prevent an electric shock or electrostatic charge, enhance the noise-resistance ability and control the unnecessary electromagnetic radiation.</li> <li>● For the ground terminal (PE) on the AC power cable of the controller and the grounding plate in the control panel, make sure for grounding work. For security grounding, it is necessary to select an appropriate wire thickness suitable for the load. Perform wiring that satisfies the specifications (electrical equipment standards and criteria). For detail, follow the description in [an instruction manual of each controller or controller built-in actuator].</li> <li>● Conduct functional grounding on the FG terminal for a controller supplying 24V DC or a controller built-in type actuator. In order to minimize influence to mechanical operation given by electromagnetic interference (noise) to an electrical device or insulation failure, conduct grounding on a terminal or a conductor that is electrically stable. The reference impedance should be Type D (Former Class 3, ground resistance 100Ω or less).</li> </ul>





No.	Operation Description	Description
4	Installation and Start	<p>(4) Safety Measures</p> <ul style="list-style-type: none"> <li>● When the work is carried out with 2 or more persons, make it clear who is to be the “leader” and who to be the “follower(s)” and communicate well with each other to ensure the safety of the workers.</li> <li>● When the product is under operation or in the ready mode, take the safety measures (such as the installation of safety and protection fence) so that nobody can enter the area within the robot’s movable range. When the robot under operation is touched, it may result in death or serious injury.</li> <li>● Make sure to install the emergency stop circuit so that the unit can be stopped immediately in an emergency during the unit operation.</li> <li>● Take the safety measure not to start up the unit only with the power turning ON. Failure to do so may start up the machine suddenly and cause an injury or damage to the product.</li> <li>● Take the safety measure not to start up the machine only with the emergency stop cancellation or recovery after the power failure. Failure to do so may result in an electric shock or injury due to unexpected power input.</li> <li>● When the installation or adjustment operation is to be performed, give clear warnings such as “Under Operation; Do not turn ON the power!” etc. Sudden power input may cause an electric shock or injury.</li> <li>● Take the measure so that the work part is not dropped in power failure or emergency stop.</li> <li>● Wear protection gloves, goggle or safety shoes, as necessary, to secure safety.</li> <li>● Do not insert a finger or object in the openings in the product. Failure to do so may cause an injury, electric shock, damage to the product or fire.</li> <li>● When releasing the brake on a vertically oriented actuator, exercise precaution not to pinch your hand or damage the work parts with the actuator dropped by gravity.</li> </ul>
5	Teaching	<ul style="list-style-type: none"> <li>● When the work is carried out with 2 or more persons, make it clear who is to be the “leader” and who to be the “follower(s)” and communicate well with each other to ensure the safety of the workers.</li> <li>● Perform the teaching operation from outside the safety protection fence, if possible. In the case that the operation is to be performed unavoidably inside the safety protection fence, prepare the “Stipulations for the Operation” and make sure that all the workers acknowledge and understand them well.</li> <li>● When the operation is to be performed inside the safety protection fence, the worker should have an emergency stop switch at hand with him so that the unit can be stopped any time in an emergency.</li> <li>● When the operation is to be performed inside the safety protection fence, in addition to the workers, arrange a watchman so that the machine can be stopped any time in an emergency. Also, keep watch on the operation so that any third person can not operate the switches carelessly.</li> <li>● Place a sign “Under Operation” at the position easy to see.</li> <li>● When releasing the brake on a vertically oriented actuator, exercise precaution not to pinch your hand or damage the work parts with the actuator dropped by gravity.</li> </ul> <p>* Safety protection Fence : In the case that there is no safety protection fence, the movable range should be indicated.</p>

No.	Operation Description	Description
6	Trial Operation	<ul style="list-style-type: none"> <li>● When the work is carried out with 2 or more persons, make it clear who is to be the “leader” and who to be the “follower(s)” and communicate well with each other to ensure the safety of the workers.</li> <li>● After the teaching or programming operation, perform the check operation one step by one step and then shift to the automatic operation.</li> <li>● When the check operation is to be performed inside the safety protection fence, perform the check operation using the previously specified work procedure like the teaching operation.</li> <li>● Make sure to perform the programmed operation check at the safety speed. Failure to do so may result in an accident due to unexpected motion caused by a program error, etc.</li> <li>● Do not touch the terminal block or any of the various setting switches in the power ON mode. Failure to do so may result in an electric shock or malfunction.</li> </ul>
7	Automatic Operation	<ul style="list-style-type: none"> <li>● Check before starting the automatic operation or rebooting after operation stop that there is nobody in the safety protection fence.</li> <li>● Before starting automatic operation, make sure that all peripheral equipment is in an automatic-operation-ready state and there is no alarm indication.</li> <li>● Make sure to operate automatic operation start from outside of the safety protection fence.</li> <li>● In the case that there is any abnormal heating, smoke, offensive smell, or abnormal noise in the product, immediately stop the machine and turn OFF the power switch. Failure to do so may result in a fire or damage to the product.</li> <li>● When a power failure occurs, turn OFF the power switch. Failure to do so may cause an injury or damage to the product, due to a sudden motion of the product in the recovery operation from the power failure.</li> </ul>

No.	Operation Description	Description
8	Maintenance and Inspection	<ul style="list-style-type: none"> <li>● When the work is carried out with 2 or more persons, make it clear who is to be the “leader” and who to be the “follower(s)” and communicate well with each other to ensure the safety of the workers.</li> <li>● Perform the work out of the safety protection fence, if possible. In the case that the operation is to be performed unavoidably inside the safety protection fence, prepare the “Stipulations for the Operation” and make sure that all the workers acknowledge and understand them well.</li> <li>● When the work is to be performed inside the safety protection fence, basically turn OFF the power switch.</li> <li>● When the operation is to be performed inside the safety protection fence, the worker should have an emergency stop switch at hand with him so that the unit can be stopped any time in an emergency.</li> <li>● When the operation is to be performed inside the safety protection fence, in addition to the workers, arrange a watchman so that the machine can be stopped any time in an emergency. Also, keep watch on the operation so that any third person can not operate the switches carelessly.</li> <li>● Place a sign “Under Operation” at the position easy to see.</li> <li>● For the grease for the guide or ball screw, use appropriate grease according to the instruction manual for each model.</li> <li>● Do not perform the dielectric strength test. Failure to do so may result in a damage to the product.</li> <li>● When releasing the brake on a vertically oriented actuator, exercise precaution not to pinch your hand or damage the work parts with the actuator dropped by gravity.</li> <li>● The slider or rod may get misaligned OFF the stop position if the servo is turned OFF. Be careful not to get injured or damaged due to an unnecessary operation.</li> <li>● Pay attention not to lose the removed cover or screws, and make sure to put the product back to the original condition after maintenance and inspection works.</li> </ul> <p>Use in incomplete condition may cause damage to the product or an injury.</p> <p>* Safety protection Fence : In the case that there is no safety protection fence, the movable range should be indicated.</p>
9	Modification and Dismantle	<ul style="list-style-type: none"> <li>● Do not modify, disassemble, assemble or use of maintenance parts not specified based at your own discretion.</li> </ul>
10	Disposal	<ul style="list-style-type: none"> <li>● When the product becomes no longer usable or necessary, dispose of it properly as an industrial waste.</li> <li>● When removing the actuator for disposal, pay attention to drop of components when detaching screws.</li> <li>● Do not put the product in a fire when disposing of it. The product may burst or generate toxic gases.</li> </ul>
11	Other	<ul style="list-style-type: none"> <li>● Do not come close to the product or the harnesses if you are a person who requires a support of medical devices such as a pacemaker. Doing so may affect the performance of your medical device.</li> <li>● See Overseas Specifications Compliance Manual to check whether complies if necessary.</li> <li>● For the handling of actuators and controllers, follow the dedicated instruction manual of each unit to ensure the safety.</li> </ul>

## Alert Indication

The safety precautions are divided into “Danger”, “Warning”, “Caution” and “Notice” according to the warning level, as follows, and described in the instruction manual for each model.

Level	Degree of Danger and Damage	Symbol
Danger	This indicates an imminently hazardous situation which, if the product is not handled correctly, will result in death or serious injury.	 Danger
Warning	This indicates a potentially hazardous situation which, if the product is not handled correctly, could result in death or serious injury.	 Warning
Caution	This indicates a potentially hazardous situation which, if the product is not handled correctly, may result in minor injury or property damage.	 Caution
Notice	This indicates lower possibility for the injury, but should be kept to use this product properly.	 Notice

## Caution in Handling

---

1. Ensure use of the product in the specified conditions, environments and ranges.

An operation out of the guarantee may cause a drop in performance or malfunction of the product.

2. Make sure to attach the actuator properly by following this instruction manual.

Using the product with the actuator not being certainly retained or affixed may cause abnormal noise, vibration, malfunction or shorten the product life.

## International Standards Compliances

---

This actuator complies with the following overseas standards.

Refer to Overseas Standard Compliance Manual (ME0287) for more detailed information.

RoHS3 Directive	CE Marking
○	Optional

## Names of the Parts

---

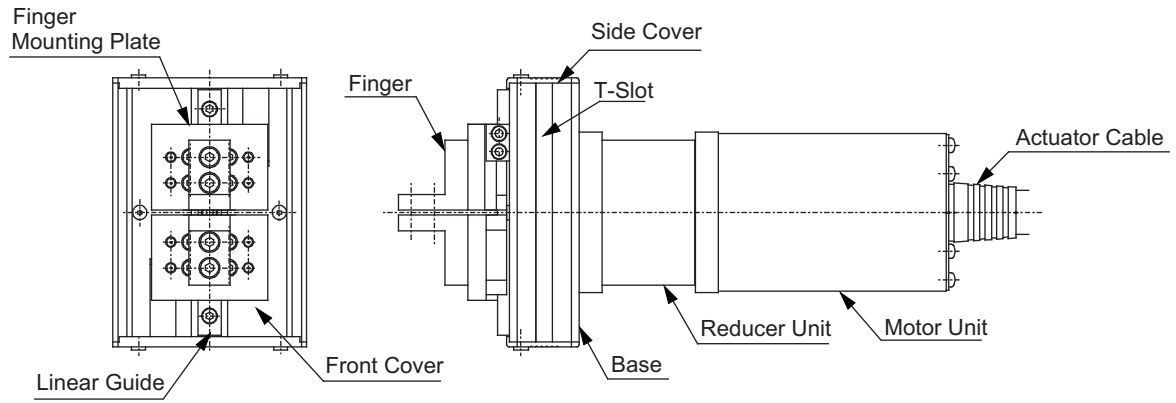

## 1. Specifications Check

### 1.1 Checking the Product

The standard configuration of this product is comprised of the following parts. See the component list for the details of the enclosed components. If you find any fault or missing parts, contact your local IAI distributor.

#### 1.1.1 Parts

No.	Name	Model Number	Quantity	Remarks
1	Actuator	Refer to "How to Read the Model Nameplate" and "How to Read the Model Number."	1	
Accessories				
2	Motor • Encoder Cables <sup>(Note1)</sup>		1 set	
3	First Step Guide		1	
4	Safety Guide		1	

Note1 The motor • encoder cables differ between the standard model and robot cable.  
[Refer to 1.3, Motor • Encoder Cables.]

#### 1.1.2 Operation Manuals for the Controllers Related to this Product

Shown below is a list of the instruction manuals for the controllers related to this product.

##### (1) XSEL-J/K Controller

No.	Name	Control No.
1	Operation Manual for XSEL-J/K Controller	ME0116
2	Operation Manual for PC Software IA-101-X-MW/IA-101-X-USBMW	ME0154
3	Operation Manual for Teaching Pendant SEL-T/TD/TG	ME0183
4	Operation Manual for Teaching Pendant IA-T-X/XD	ME0160
5	Operation Manual for DeviceNet	ME0124
6	Operation Manual for CC-Link	ME0123
7	Operation Manual for PROFIBUS	ME0153
8	Operation Manual for X-SEL Ethernet	ME0140
9	Operation Manual for Multi-Point I/O Board	ME0138
10	Operation Manual for Multi-Point I/O Board Dedicated Terminal Board	ME0139

(2) XSEL-P/Q Controller

No.	Name	Control No.
1	Operation Manual for XSEL-P/Q Controller	ME0148
2	Operation Manual for XSEL-P/Q/PX/QX RC Gateway Function	ME0188
3	Operation Manual for PC Software IA-101-X-MW/IA-101-X-USBMW	ME0154
4	Operation Manual for Teaching Pendant SEL-T/TD/TG	ME0183
5	Operation Manual for Teaching Pendant IA-T-X/XD	ME0160
6	Operation Manual for DeviceNet	ME0124
7	Operation Manual for CC-Link	ME0123
8	Operation Manual for PROFIBUS	ME0153

(3) XSEL-R/S Controller

No.	Name	Control No.
1	SEL Language Programming Manual	ME0224
2	XSEL Controller P/Q/PX/QX/PCT/QCT/R/S/RX/SX/RXD/SXD	ME0188
3	PC Software IA-101-X-MW/ IA-101-X-USBMW RC Gateway Function Operation Manual	ME0154
4	Teaching Pendant SEL-T/TD/TG Operation Manual	ME0183
5	Teaching Pendant IA-T-X/XD Operation Manual	ME0160
6	DeviceNet Operation Manual	ME0124
7	CC-Link Operation Manual	ME0123
8	PROFIBUS-DP Operation Manual	ME0153
9	Ethernet Operation Manual	ME0140
10	EtherCAT Operation Manual	ME0309
11	EtherNet/IP Operation Manual	ME0308
12	IA Net Operation Manual	ME0307

(4) SSEL Controller

No.	Name	Control No.
1	Operation Manual for SSEL Controller	ME0157
2	Operation Manual for PC Software IA-101-X-MW/IA-101-X-USBMW	ME0154
3	Operation Manual for Teaching Pendant SEL-T/TD/TG	ME0183
4	Operation Manual for Teaching Pendant IA-T-X/XD	ME0160
5	Operation Manual for DeviceNet	ME0124
6	Operation Manual for CC-Link	ME0123
7	Operation Manual for PROFIBUS	ME0153

## (5) SCON Controller

No.	Name	Control No.
1	Operation Manual for SCON Controller	ME0161
2	Operation Manual for SCON-CA Controller	ME0243
3	Operation Manual for PC Software RCM-101-MW/RCM-101-USB	ME0155
4	Operation Manual for Teaching Pendant CON-T/TG	ME0178
5	Operation Manual for Touch Panel Teaching CON-PT/PD/PG	ME0227
6	Operation Manual for Simplified Teaching Pendant RCM-E	ME0174
7	Operation Manual for Data setter RCM-P	ME0175
8	Operation Manual for Touch Panel Display RCM-PM-01	ME0182
9	Operation Manual for DeviceNet	ME0124
10	Operation Manual for CC-Link	ME0123
11	Operation Manual for PROFIBUS	ME0153

## 1.1.3 How to Read the Model Nameplate

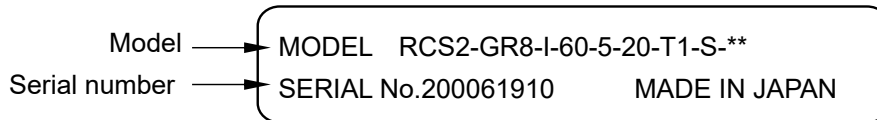

## 1.1.4 How to read the Model Number

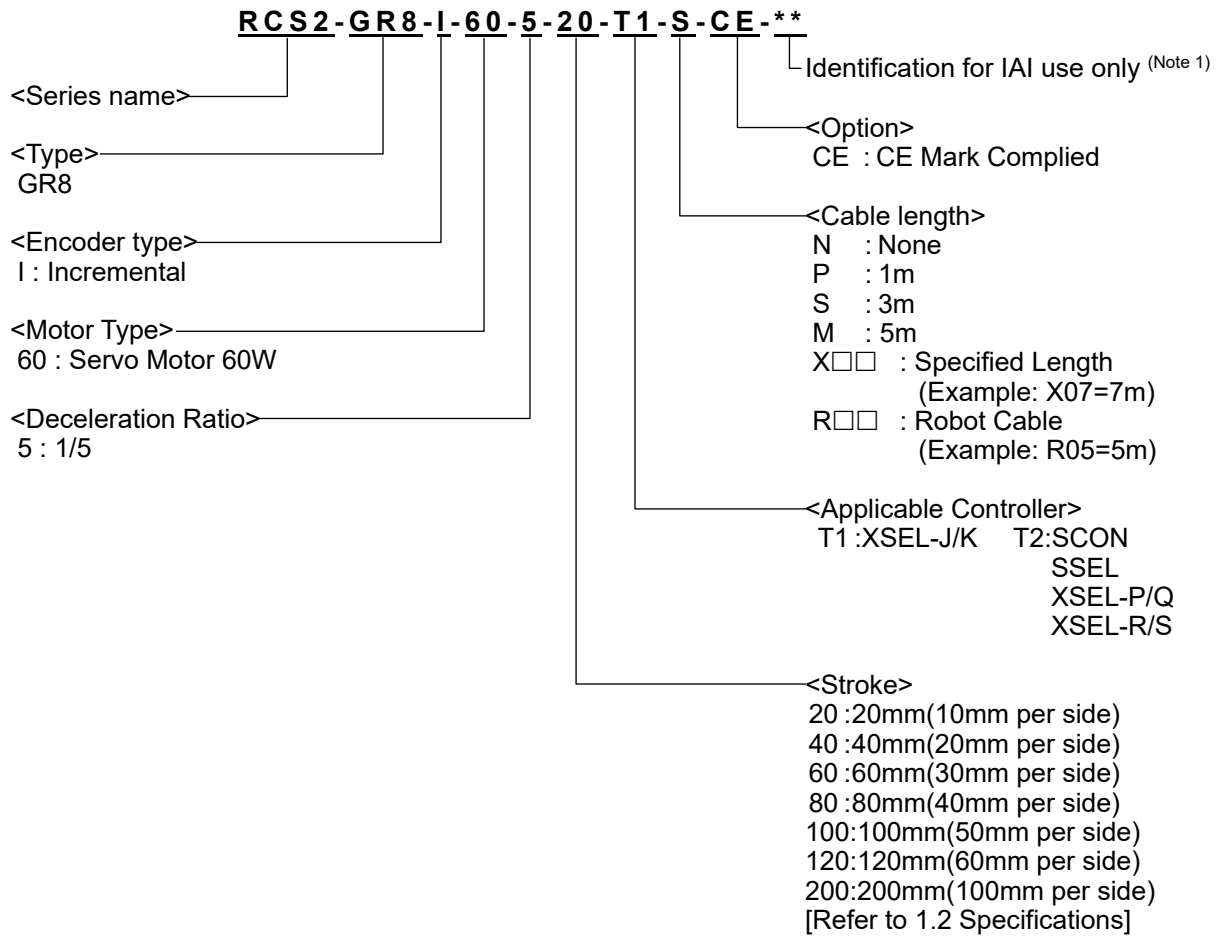

Note1 It may be displayed for IAI use. (It is not a code to show the model type.)

## 1.2 Specifications

### 1.2.1 Specifications Table

Open/Close Stroke	[mm]	20 (10 mm per side)	40 (20 mm per side)	60 (30 mm per side)	80 (40 mm per side)	100 (50 mm per side)	120 (60 mm per side)	200 (100 mm per side)
Rated Output	[W]	60						
Max. Back and Forth Operation Times	[cpm]	60						
Holding Force at Operation Stop <small>(Note 1)</small>	[N(kgf)]	22.5(2.3)						
Rated Holding Force during Operation <small>(Note 2)</small>	[n(kgf)]	31.3(3.2)						
Maximum Speed	[mm/s]	400						
Maximum Acceleration / Deceleration Speed	[G]	0.3						
Positioning Accuracy Repeatability <small>(Note 3) (Note 5)</small>	[mm]	± 0.04						
Lost Motion <small>(Note 4) (Note 5)</small>	[mm]	0.7 mm or less						
Backlash	[mm]	1.3(total of both sides)						
Driving System	—	Rack & Pinion						
Base	—	Material: White Anodized Aluminum						
Weight	[kg]	1.8	1.9	1.9	2.0	2.0	2.1	2.3

Note 1 It is the load limit allowable value at a stop.

Note 2 It is an allowable value during an operation.

Note 3 It is a value of positioning on one side ignoring the lost motion.

Note 4 It is the lost motion of rack and pinion + speed reducer.

Note 5 The values shown above are the accuracy at the delivery from the factory.  
It does not include the consideration of time-dependent change as it is used.

 **Caution :** Do not attempt to establish a setting of more than maximum speed or acceleration. Operation above the allowable range may cause malfunction or shortening of the product life.

## 1.2.2 Allowable Load Moment of the Actuator

Allowable Static Load Moment [N·m]		
Ma	Mb	Mc
5.1	5.1	10.4

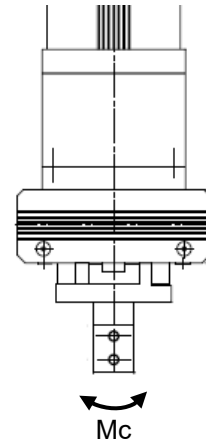
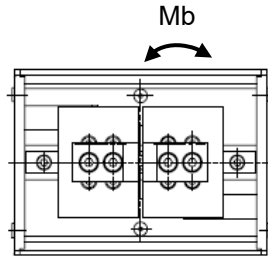
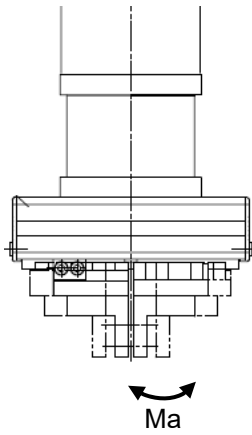

**Caution :** Set the allowable load moment within the allowable range. Operation above the allowable range may cause malfunction or shortening of the product life.

### 1.3 Motor • Encoder Cables

#### 1.3.1 Motor Cable / Motor Robot Cable

CB-RCC-MA□□□ / CB-RCC-MA□□□-RB

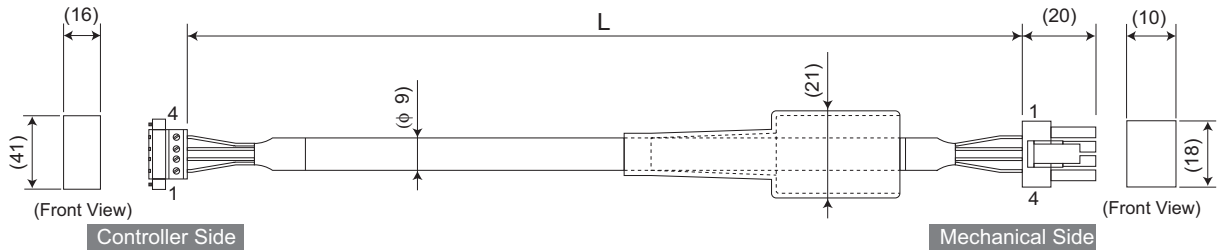

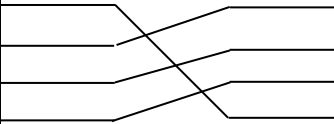
Width	Electric wire color	Signal name	Pin No.		Pin No.	Signal name	Electric wire color	Width
AWG18	Green	PE	1		1	U	Red	AWG18 (Solderless)
	Red	U	2		2	V	White	
	White	V	3		3	W	Black	
	Black	W	4		4	PE	Green	

## 1.3.2 Encoder Cable / Encoder Robot Cable

CB-RCS2-PA□□□□ / CB-RCS2-PA□□□□-RB (For SCON, SSEL, XSEL-P/Q)

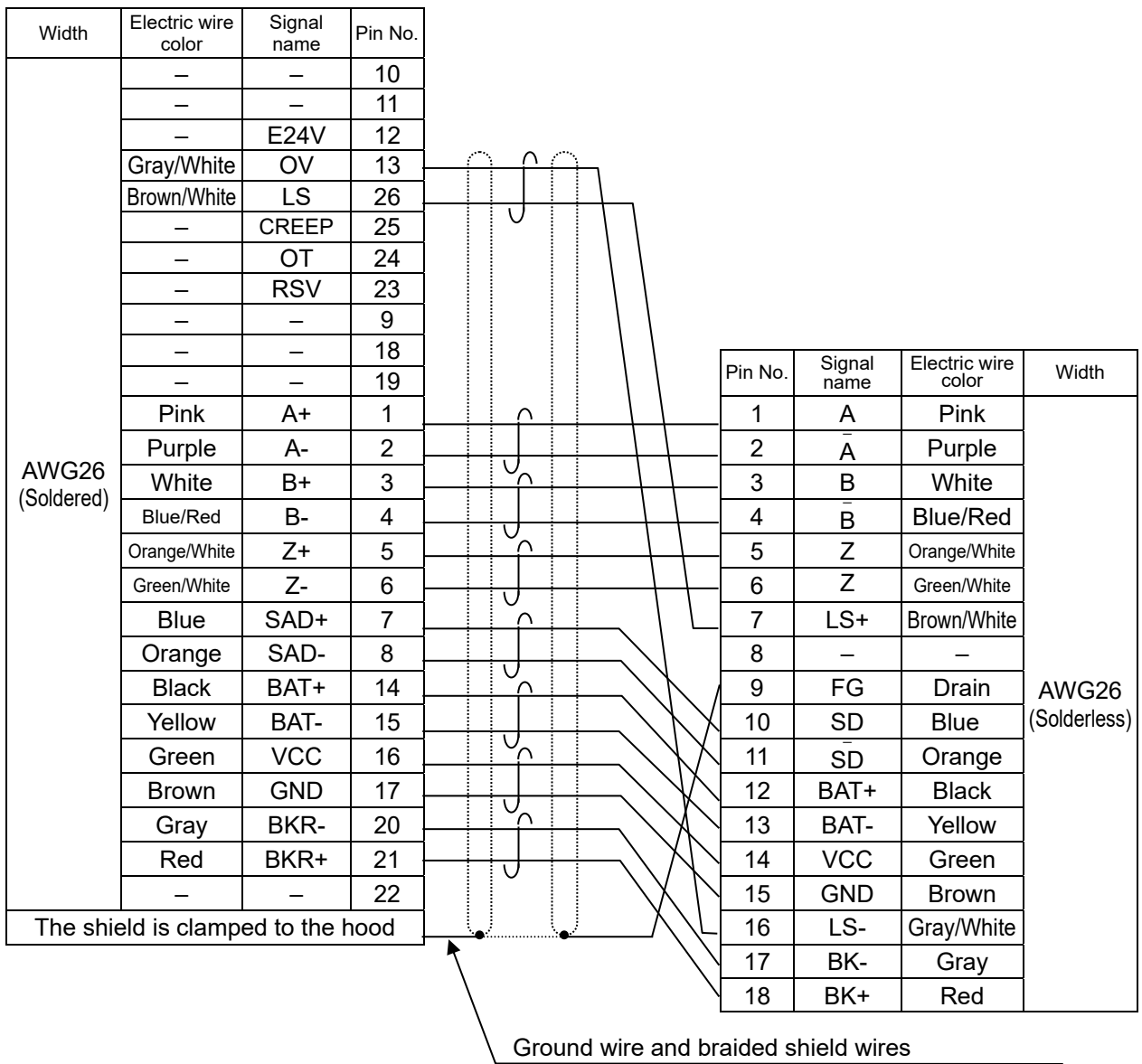
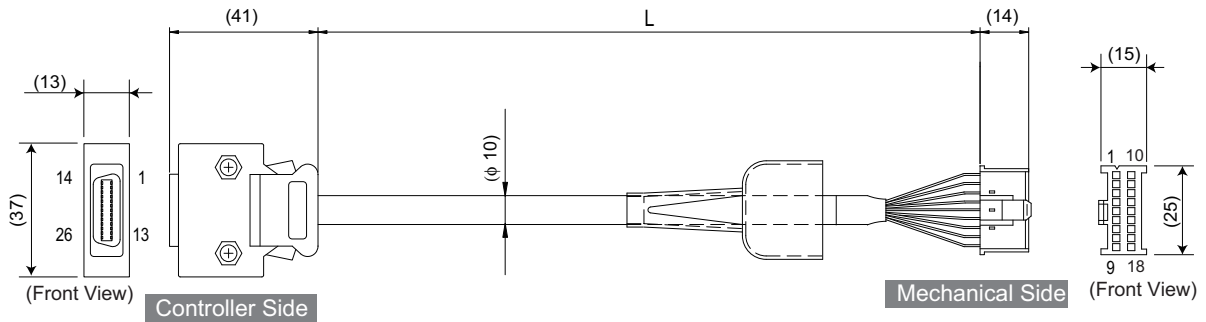

CB-RCBC-PA□□□ / CB-RCBC-PA□□□-RB (For XSEL-J/K)

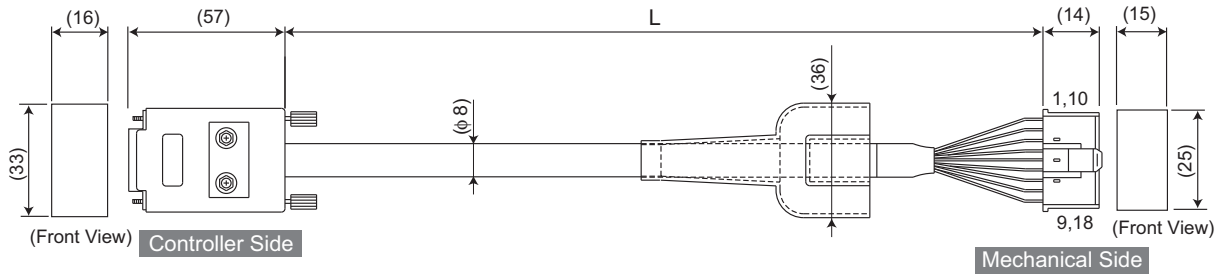

Width	Electric wire color	Signal name	Pin No.	Pin No.	Signal name	Electric wire color	Width
AWG25 (Solderless)	Pink	A/U	1	1	A/U	Pink	AWG25 (Solderless)
	Purple	A/U	2	2	A/U	Purple	
	White	B/V	3	3	B/V	White	
	Blue/Red	B/V	4	4	B/V	Blue/Red	
	Orange/White	Z/W	5	5	Z/W	Orange/White	
	Green/White	Z/W	6	6	Z/W	Green/White	
	Blue	SD	7	7	-	-	
	Orange	SD	8	8	-	-	
	Black	BAT+	9	9	FG	Drain	
	Yellow	BAT-	10	10	SD	Blue	
	Green	VCC	11	11	SD	Orange	
	Brown	GND	12	12	BAT+	Black	
	Gray	BK-	13	13	BAT-	Yellow	
	Red	BK+	14	14	VCC	Green	
-	-	15	15	GND	Brown		
The shield is clamped to the hood				16	-	-	
				17	BK-	Gray	
				18	BK+	Red	

## 2. Installation

### 2.1 Transportation

#### [1] Handling of the Robot

Unless otherwise specified, the actuators are wrapped individually when the product is shipped out.

##### (1) Handling of the Packed Unit

- Do not damage or drop. The package is not applied with any special treatment that enables it to resist an impact caused by a drop or crash.
- An operator should never attempt to carry a heavy package on their own. Also, use an appropriate way for transportation.
- Keep the unit in horizontal orientation when placing it on the ground or transporting. Follow the instruction if there is any for the packaging condition.
- Do not step or sit on the package.
- Do not put any load that may cause a deformation or breakage of the package.

##### (2) Handling after Unpackaged

- Do not carry the actuator by holding the cable, or do not move it by pulling the cable.
- When transporting the actuator main unit, hold the base or bracket part.
- Do not hit or drop the product while carrying.
- Do not give any excessive force to any of the sections in the actuator.

**[2] Handling in Assembled Condition**

It is applied to the case that this product is assembled with other actuators and shipped out from our factory.

**(1) Handling of the Packed Unit**

- Do not damage or drop. The package is not applied with any special treatment that enables it to resist an impact caused by a drop or crash.
- An operator should never attempt to carry a heavy package on their own. Also, use an appropriate way for transportation.
- When suspending the package using ropes, pass the ropes from underneath the reinforcement frames at the bottom of the base. When lifting with a forklift, also place the forks underneath the base.
- Do not attempt to apply impact on the product or make it bounce when putting it on.
- Do not step or sit on the package.
- Do not put any load that may cause a deformation or breakage of the package.

**(2) Handling after Unpackaged**

- Appropriately fix the tip of the actuators if it is overhanging so it would not widely shake with external vibration. If the actuator assembly is transported without the ends being secured, do not apply an impact of 0.3G or more.
- In the case that the actuator needs to be carried up with ropes or another method, be sure to use an appropriate cushioning to avoid the robot being deformed or put on an excessive pressure. And also, be sure to keep the robot in a stable and horizontal posture. Make a tool to utilize the attachment holes and tapped holes on the actuator and attach it if necessary.
- Do not attempt to apply load to the actuator or connector box. Also, avoid the cables being pinched or caused an excessive deformation.

**[3] Handling of the Robot Mounted on Mechanical Equipment (System)**

The following are the cautions for when transporting the actuators installed in the machinery equipment (system) in the whole system.

- Fix the table firmly so it would not move during transportation.
- Appropriately fix the tip of the actuators if it is overhanging so it would not widely shake with external vibration. If the actuator assembly is transported without the ends being secured, do not apply an impact of 0.3G or more.
- Do not attempt to apply load to actuators or connector box when hanging the machinery equipment (system) with tools such as a rope. Also, avoid the cables being pinched or caused an excessive deformation.

## 2.2 Installation and Storage • Preservation Environment

### [1] Installation Environment

The actuator should be installed in a location other than those specified below. Also provide sufficient work space required for maintenance inspection.

- Where the actuator receives radiant heat from strong heat sources such as heat treatment furnaces
- Where the ambient temperature exceeds the range of 0 to 40°C
- Where the temperature changes rapidly and condensation occurs
- Where the relative humidity exceeds 85% RH
- The product gains the water-proof performance of IP65 protection structure if an air purge is conducted.
- Where the actuator is exposed to corrosive or combustible gases
- Where the ambient air contains a large amount of powder dust, salt or iron (at level exceeding what is normally expected in an assembly plant)
- Where the actuator is subject to splashed water, oil (including oil mist or cutting fluid) or chemical solutions
- Where the actuator receives impact or vibration

If the actuator is used in any of the following locations, provide sufficient shielding measures:

- Where noise generates due to static electricity, etc.
- Where the actuator is subject to a strong electric or magnetic field
- Where the actuator is subject to ultraviolet ray or radiation

### [2] Storage • Preservation Environment

- The storage and preservation environment should comply with the same standards as those for the installation environment. In particular, when the machine is to be stored for a long time, pay close attention to environmental conditions so that no dew condensation forms.
- Unless specially specified, moisture absorbency protection is not included in the package when the machine is delivered. In the case that the machine is to be stored and preserved in an environment where dew condensation is anticipated, take the condensation preventive measures from outside of the entire package, or directly after opening the package.
- For storage and preservation temperature, the machine withstands temperatures up to 60°C for a short time, but in the case of the storage and preservation period of 1 month or more, control the temperature to 50°C or less.
- Storage and preservation should be performed in the horizontal condition. In the case it is stored in the packaged condition, follow the posture instruction if any displayed on the package.

## 2.3 How to Installation

This chapter explains how to install the actuator on your mechanical system.

### 2.3.1 Installation Orientation

Shown below are the basic concepts for the product attachment.  
Pay special attention when deciding how to install the product (Except with custom-order models).

○ : Available    × : Not available

Horizontal Installation	Vertical Installation	Sideways Installation
○	○	○

Installation orientation

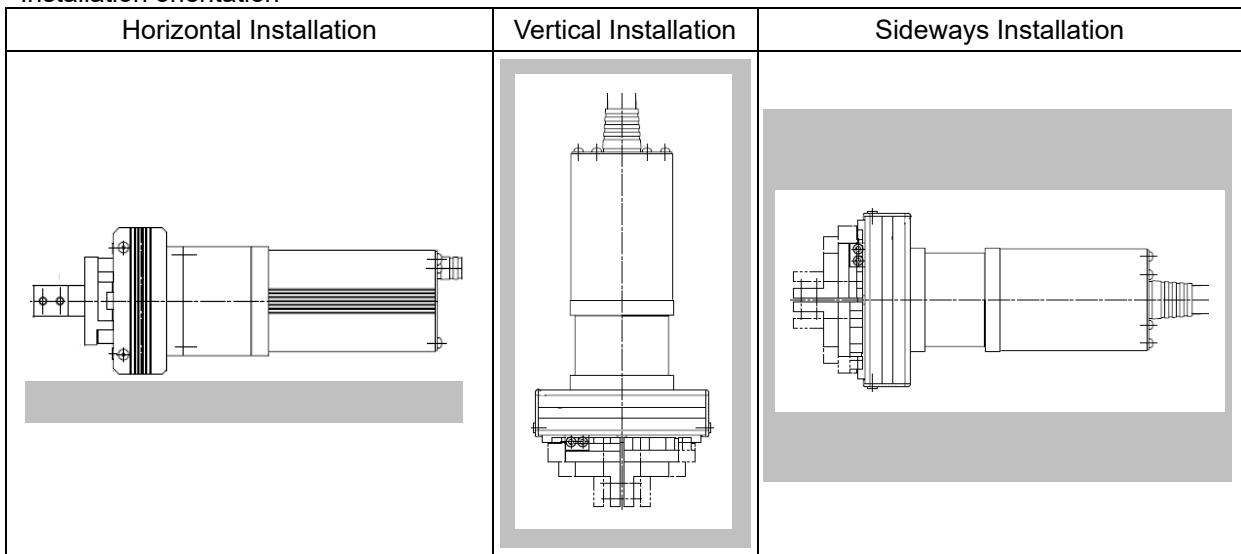

## 2.3.2 Installation

### [1] Installation of the Main Unit

There are T-shaped grooves for M6 on the right and left of the base. Utilize these T-slots for the attachment of bracket and other equipments by putting in nuts and tightening with screws.

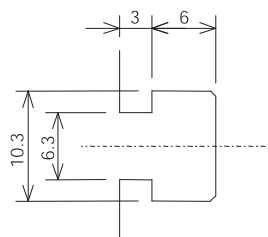
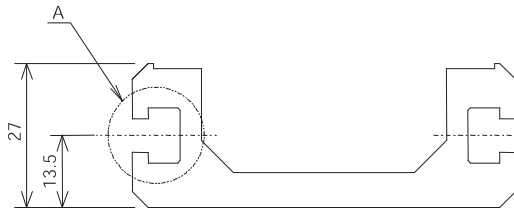

Detail A

Nut	M6 T-nut (recommended) or square nut
Screw	M6 × 8 (Note 1)

Note1 Thread length should be 8mm maximum due to the T-slot depth. Select a screw with a thread length that is equivalent to the thickness of screw seat on the attached part + 8mm.

### [2] How to a Insert Nut

To insert a nut to the T-slot, the side cover needs to be removed.

- 1) Remove the screws securing the side cover.
- 2) Slide the side cover in the arrow direction to take off.

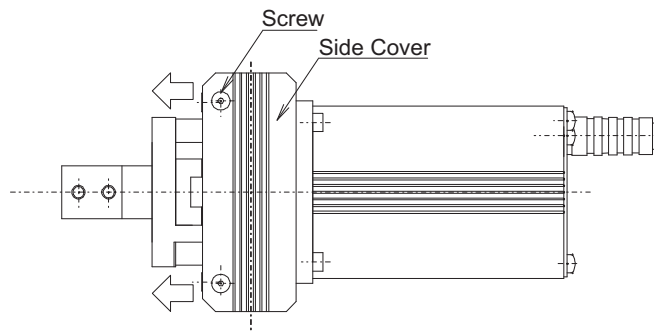

- 3) Put a nut in the T-slot, and slide in the side cover to the opposite direction of the arrows to put back.
- 4) Tighten the screws.

[3] Installation of the Finger Attachments  
Please prepare the finger attachments separately.

- Finger Mounting Plate Screw Attachment Positions

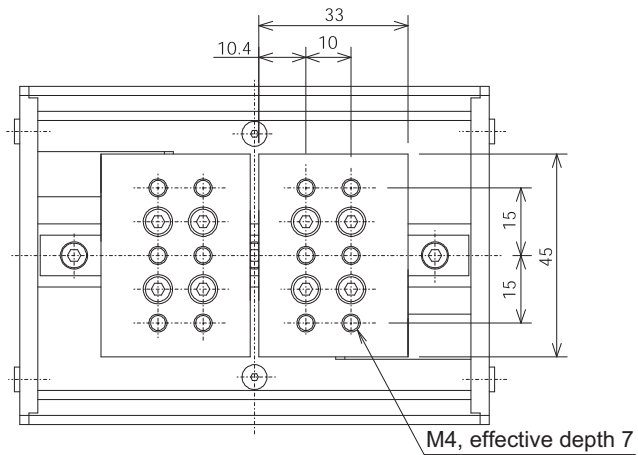

Finger Profile

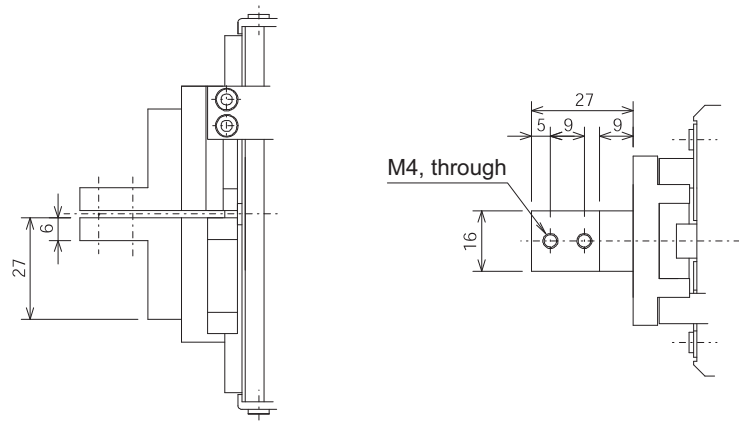

**⚠ Caution :** Pay attention to the selection of the screw length. Use of inappropriate length of screws may cause a destruction of the tapped holes, insufficient holding strength of the actuator or interference on the driving part, which may result in a drop of the accuracy or an unexpected accident.

### 3. Connecting to the Controller

As the connection cable for the controller and actuator, use the IAI-dedicated controller and dedicated connection cable.

In this section, describes how to lay out the wirings for the single axis use.

- In a use of the actuator with the dedicated connection cables not fixed, consider to ease the load to the dedicated connection cables by using the actuator in the range of the cable bends only with its weight or by using a stand-alone cable hose to gain a large radius bending.
- Do not attempt to cut and extend, shorten or rejoin the dedicated connection cables.
- Do not attempt to pull or bend the dedicated connection cables forcefully.
- The actuator cable coming out of the motor unit is not meant to be bent. Fix the cable so it would not be bent repeatedly.

Please us if there is a request of the specification change to the dedicated connection cables.

[Connection to the SCON and SSEL controller]

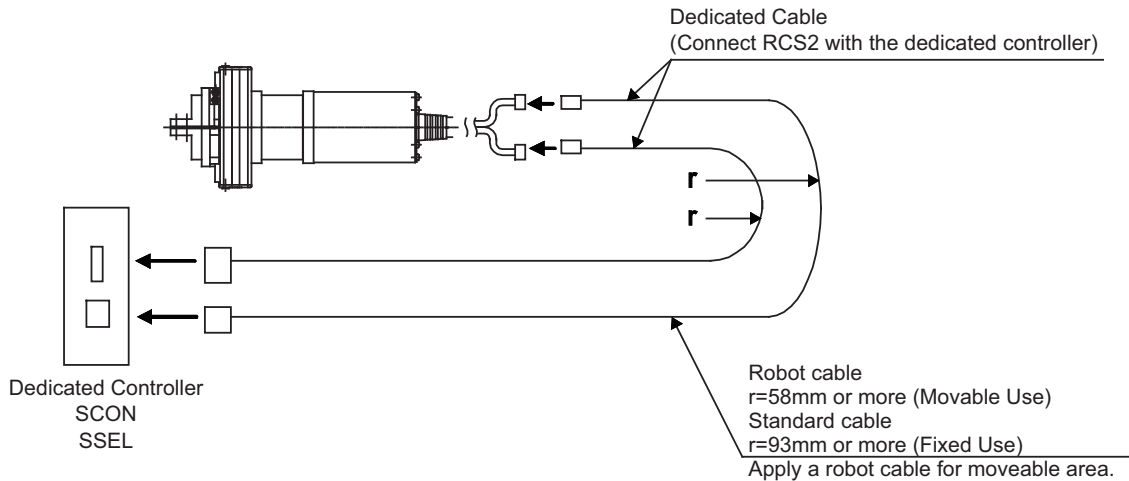

#### Dedicated Cable

- Motor Cable CB-RCC-MA□□□/ Motor Cable Robot Cables CB-RCC-MA□□□-RB
  - Encoder Cable CB-RCS2-PA□□□/ Encoder Cable Robot Cables CB-X3-PA□□□
- shows the cable length. The max. length should be 30m.  
Example) 080=8m

[Connection to the X-SEL controller]

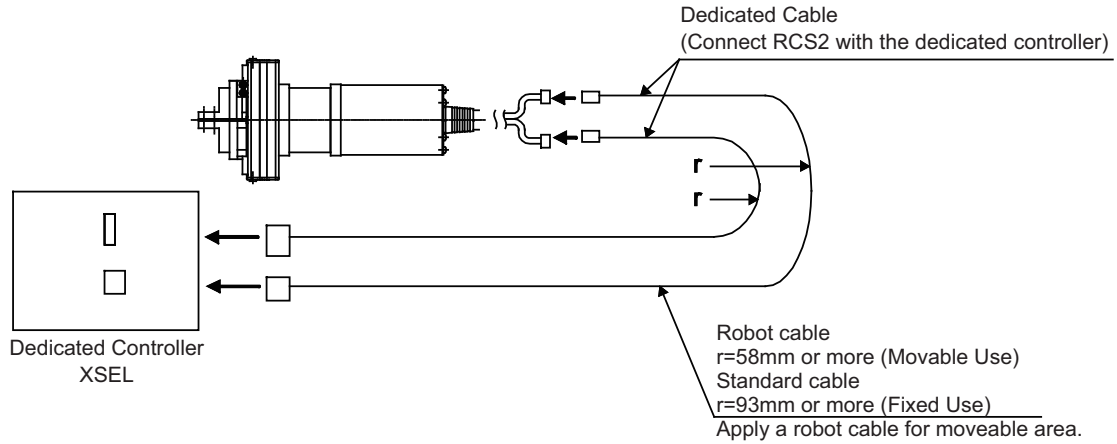

#### Dedicated Cable

- Motor Cable CB-RCC-MA□□□/ Motor Cable Robot Cables CB-RCC-MA□□□-RB
- Encoder Cables for XSEL-J/K Types CB-RCBC-PA□□□  
Encoder Cable Robot Cables for XSEL-J/K Types CB-RCBC-PA□□□-RB
- Encoder Cables for XSEL-P/Q, R/S Types CB-RCS2-PA□□□  
Encoder Cable Robot Cables for XSEL-P/Q, R/S Types CB-X3-PA□□□  
□□□ shows the cable length.  
The max. length should be 15m. The maximum applicable length for other cables is 20m.  
Example) 080=8m



Warning: For wiring, please follow the warnings stated below. When constructing a system as the machinery equipment, pay attention to the wiring and connection of each cable so they are conducted properly. Not following them may cause not only a malfunction such as cable breakage or connection failure, or an operation error, but also electric shock or electric leakage, or may even cause a fire.

- Use dedicated cables of IAI indicated in this instruction manual. Contact us if you wish to have a change to the specifications of the dedicated cables.
- Make sure to turn the power off in the process of power line or cable connection or disconnection.
- Do not attempt to cut a dedicated cable with connectors on both ends to extend, shorten or re-joint it.
- Hold the dedicated cable to avoid mechanical force being applied to the terminals and connectors.
- Use a cable pipe or duct to have an appropriate protection when there is a possibility of mechanical damage on a dedicated cable.
- In case a dedicated cable is to be used at a moving part, make sure to lay out the cable without applying any force to pull the connector or extreme bend on the cable. Do not attempt to use the cable with a bending radius below the allowable value.
- Make certain that the connectors are plugged properly. Insufficient connection may cause an operation error, thus it is extremely risky.
- Do not lay out the cables to where the machine runs over them.
- Pay attention to the cable layout so it would not hit peripherals during an operation. In case it does, have an appropriate protection such as a cable track.
- When a cable is used hanging on the ceiling, prevent an environment that the cable swings with acceleration or wind velocity.
- Make sure there is not too much friction inside the cable storage equipment.
- Do not apply radiated heat to power line or cables.
- Have a sufficient radius for bending, and avoid a bend concentrating on one point.

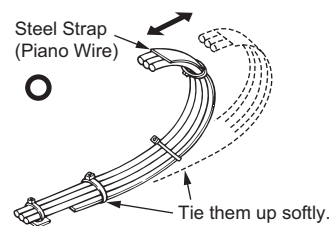
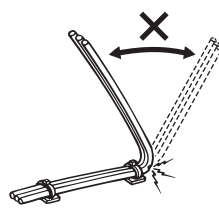

- Do not let the cable bend, kink or twist.

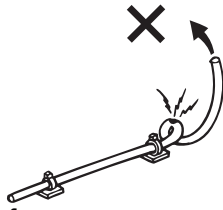

- Do not pull the cable with a strong force.

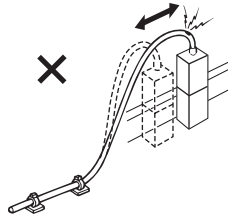

- Pay attention not to concentrate the twisting force to one point on a cable.

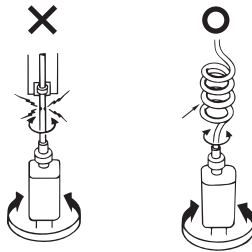

- Do not pinch, drop a heavy object onto or cut the cable.

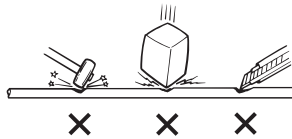

- When a cable is fastened to affix, make sure to have an appropriate force and do not tighten too much.

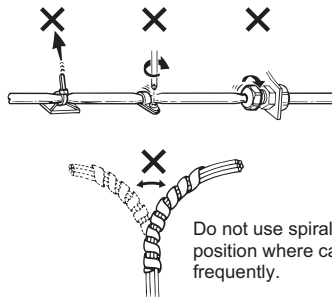

Do not use spiral tube in any position where cables are bent frequently.

- PIO line, communication line, power and driving lines are to be put separately from each other and do not tie them together. Arrange so that such lines are independently routed in the duct.

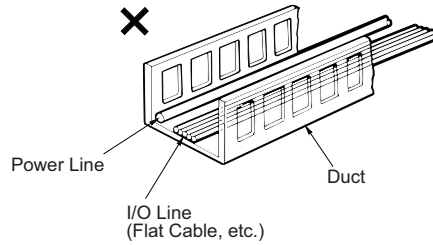

- If using a cable track, arrange the wiring so that there is no entanglement or kink of the cables in the cable carrier or flexible tube, and do not bind the cables so that the cables are relatively free. (Arrange the wiring so the cables are not to be pulled when bent.)

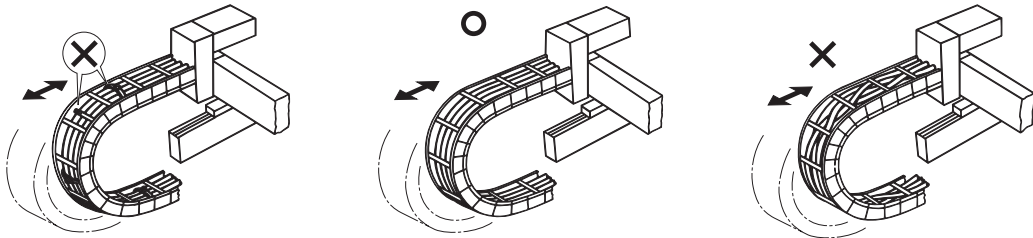

- The occupied volume rate for the cables, etc., inside the cable track should be 60% or less.

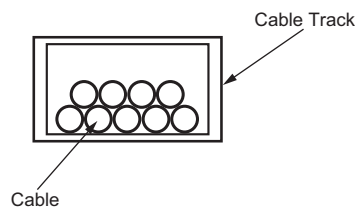

## 4. Caution for Operation (Finger Operations)

### [1] Finger Stroke

The design stroke of the two-finger type is a sum of travel distances of both fingers. In other words, the travel distance of one finger is one-half the design stroke.

### [2] Home-Return Direction

The side of that the fingers are open (closer to the side cover) is defined as the home position.

### [3] Position Specification caution

The travel distance of each finger from its home position toward the closing side is defined as the position value.

(Max. position value indication = 1/2 of stroke)

### [4] Speed/acceleration Commands

Speed/acceleration commands are specified based on a value per finger. The relative speed and acceleration of the two-finger type is twice the command value.

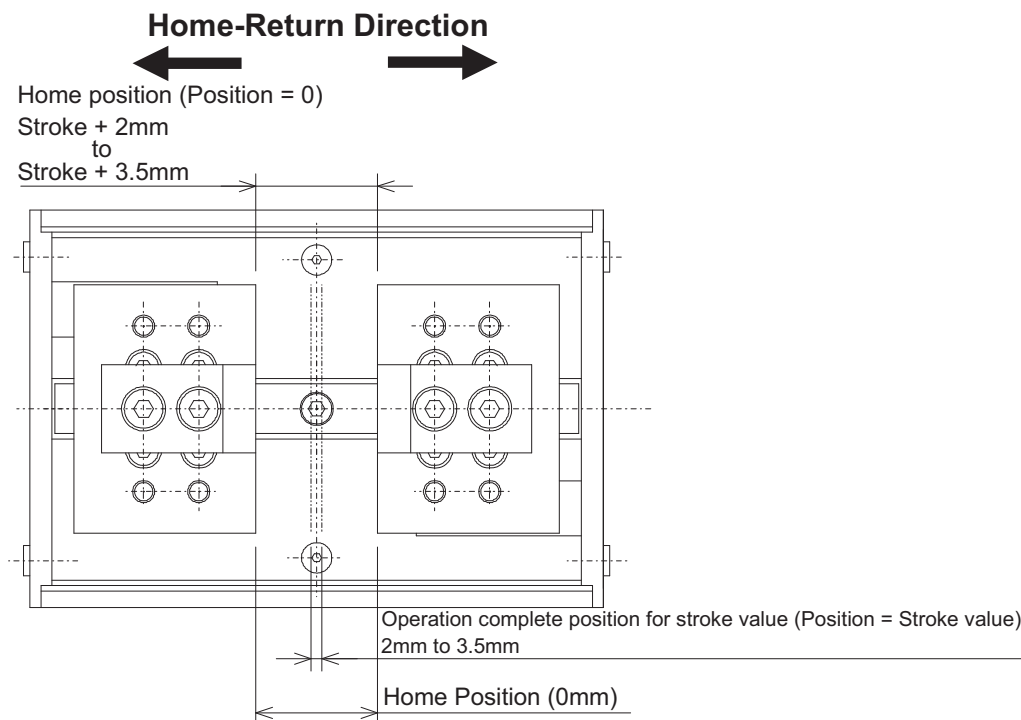

### [5] Indication of Pressing Operation Direction

For the pressing to inner direction, set the value adding a positive value to the position value. For the pressing to outer direction, set the value adding a negative value to the position value.

## 5. Maintenance Inspection

### 5.1 Inspection Items and Inspection Schedule

Have maintenance inspections following the intervals below.

The calculation is conducted under the condition that there are 8 working hours per day. Have inspections more frequently if the operation frequency is high for night and day continuous operation, etc.

	Visual inspection	Grease supply
At startup inspection	○	
1 month after start of operation	○	
6 months after start of operation	○	○
1 year after start of operation	○	
Every 6 months thereafter	○	○
Every year thereafter	○	

### 5.2 Visual Inspection

For the visual inspection, check the appearance following items.

Actuator	Loosening of actuator mounting bolts, etc.
Cables	Scratches, proper connection of connectors
Overall	Noise, vibration

### 5.3 Cleaning

- Please clean the external body on a regular basis.
- When cleaning, wipe with a soft cloth to remove dust and dirt.
- There is a risk of dust getting in from a clearance. Do not blow compressed air strongly to the body.
- Do not apply petroleum solvent since it may damage the resin or painted surfaces.
- When extremely dirty, wipe it off firmly with cloth that a neutral detergent or alcohol is applied on.

## 5.4 Grease Supply

### 5.4.1 Applied Grease on Guides

The following grease is applied when the product is shipped out from IAI factory.

Linear guide	Kyodo Yushi	Mul Temp LRL
--------------	-------------	--------------

Apart from above, there are equivalent sorts of grease sold in the market. For details contact a grease supplier, provide the grease name shown above and ask them to select an equivalent. Listed below are some equivalents for an example.

Supply grease only on the linear guide part.

 **Warning :** Do not use fluorine based grease. Do not attempt to apply fluorine grease. When mixed with lithium grease, not only decrease the grease characteristics, but also may damage the actuator.

 **Caution:** In case the grease got into your eye, immediately go see the doctor to get appropriate care.  
After finishing the grease supply work, wash your hands carefully with water and soap to rinse the grease off.

## 6. External Dimensions

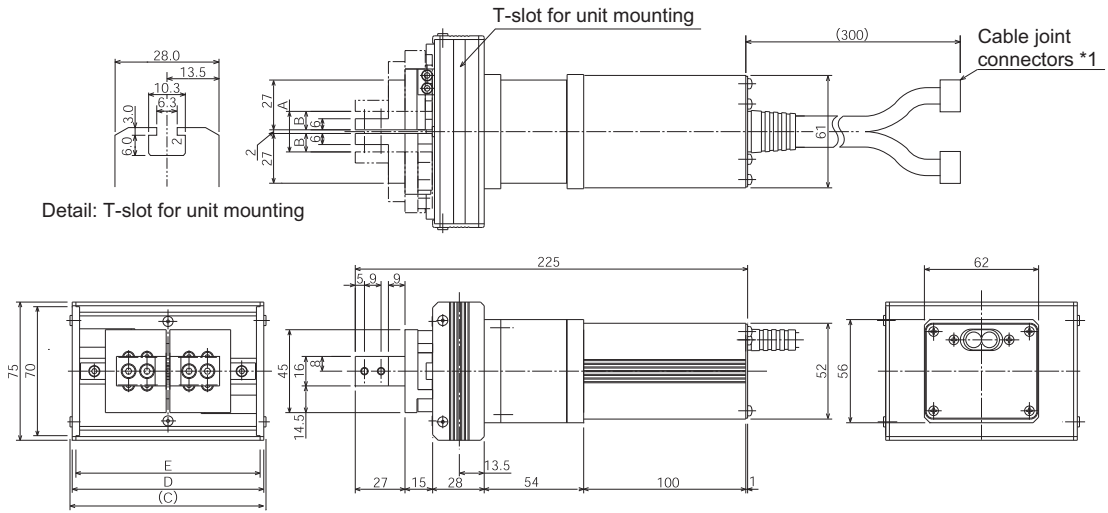

Stroke	20	40	(60)	(80)	100	(120)	(200)
A	22	42	62	82	102	122	202
B	10	20	30	40	50	60	100
C	106.4	126.4	146.4	166.4	186.4	206.4	286.4
D	104	124	144	164	184	204	284
E	100	120	140	160	180	200	280
Weight (kg)	1.8	1.9	1.9	2.0	2.0	2.1	2.3

## 7. Warranty

### 7.1 Warranty Period

One of the following periods, whichever is shorter:

- 18 months after shipment from our company
- 12 months after delivery to the specified location
- 2,500 hours of operation

### 7.2 Scope of the Warranty

Our products are covered by warranty when all of the following conditions are met. Faulty products covered by warranty will be replaced or repaired free of charge:

- (1) The breakdown or problem in question pertains to our product as delivered by us or our authorized dealer.
- (2) The breakdown or problem in question occurred during the warranty period.
- (3) The breakdown or problem in question occurred while the product was in use for an appropriate purpose under the conditions and environment of use specified in the Operation Manual and catalog.
- (4) The breakdown or problem in question was caused by a specification defect or problem, or by the poor quality of our product.

Note that breakdowns due to any of the following reasons are excluded from the scope of warranty:

- [1] Anything other than our product
- [2] Modification or repair performed by a party other than us (unless we have approved such modification or repair)
- [3] Anything that could not be easily predicted with the level of science and technology available at the time of shipment from our company
- [4] A natural disaster, man-made disaster, incident or accident for which we are not liable
- [5] Natural fading of paint or other symptoms of aging
- [6] Wear, depletion or other expected result of use
- [7] Operation noise, vibration or other subjective sensation not affecting function or maintenance

Note that the warranty only covers our product as delivered and that any secondary loss arising from a breakdown of our product is excluded from the scope of warranty.

### 7.3 Honoring the Warranty

As a rule, the product must be brought to us for repair under warranty.

### 7.4 Limited Liability

- (1) We shall assume no liability for any special damage, consequential loss or passive loss such as a loss of expected profit arising from or in connection with our product.
- (2) We shall not be liable for any program or control method created by the customer to operate our product or for the result of such program or control method.

## 7.5 Conditions of Conformance with Applicable Standards/Regulations, Etc., and Applications

- (1) If our product is combined with another product or any system, device, etc., used by the customer, the customer must first check the applicable standards, regulations and/or rules. The customer is also responsible for confirming that such combination with our product conforms to the applicable standards, etc. In such a case we will not be liable for the conformance of our product with the applicable standards, etc.
- (2) Our product is for general industrial use. It is not intended or designed for the applications specified below, which require a high level of safety. Accordingly, as a rule our product cannot be used in these applications. Contact us if you must use our product for any of these applications:
  - [1] Medical equipment pertaining to maintenance or management of human life or health
  - [2] A mechanism or mechanical equipment intended to move or transport people (such as a vehicle, railway facility or aviation facility)
  - [3] Important safety parts of mechanical equipment (such as safety devices)
  - [4] Equipment used to handle cultural assets, art or other irreplaceable items
- (3) Contact us at the earliest opportunity if our product is to be used in any condition or environment that differs from what is specified in the catalog or Operation Manual.

## 7.6 Other Items Excluded from Warranty

The price of the product delivered to you does not include expenses associated with programming, the dispatch of engineers, etc. Accordingly, a separate fee will be charged in the following cases even during the warranty period:

- [1] Guidance for installation/adjustment and witnessing of test operation
- [2] Maintenance and inspection
- [3] Technical guidance and education on operating/wiring methods, etc.
- [4] Technical guidance and education on programming and other items related to programs

## Change History

Revision Date	Description of Revision
2010.10	First Edition
2012.09	Second Edition Please Read Before Used added International Standards Compliances added Additions and Changes made in Safety Guide contents Contents changed in 3. Warranty in Pg.15 to Pg. 16.
2012.11	Third Edition Revised overall
2013.11	Fourth Edition Pg.15 Backlash 1.3mm (total of both sides) added in specification list
2025.06	Edition 4C DVD instruction manual discontinued enclosed International Standards Compliances complied with RoHS3 Grease name changed







## ***IAI Corporation***

Head Office: 1210 Iharacho Shimizu-KU Shizuoka City Shizuoka 424-0114, Japan  
TEL +81-54-364-5105 FAX +81-54-364-2589  
website: [www.iai-robot.co.jp/](http://www.iai-robot.co.jp/)

## ***IAI America, Inc.***

Head Office: 2690 W. 237th Street, Torrance, CA 90505  
TEL +1-310-891-6015 FAX +1-310-891-0815  
Chicago Office: 110 East State Parkway, Schaumburg, IL 60173  
TEL +1-847-908-1400 FAX +1-847-908-1399  
Atlanta Office: 1220 Kennestone Circle, Suite 108, Marietta, GA 30066  
TEL +1-678-354-9470 FAX +1-678-354-9471  
website: [www.intelligentactuator.com](http://www.intelligentactuator.com)

Technical Support available in Europe

## ***IAI Industrieroboter GmbH***

Ober der Röth 4, D-65824 Schwalbach am Taunus, Germany  
TEL +49(0)6196-88950 FAX +49(0)6196-889524  
website: [www.iai-automation.com](http://www.iai-automation.com)

Technical Support available in Great Britain



Duttons Way, Shadsworth Business Park, Blackburn, Lancashire, BB1 2QR, United Kingdom  
TEL +44(0)1254-685900  
website: [www.lcautomation.com](http://www.lcautomation.com)

## ***IAI (Shanghai) Co., Ltd.***

SHANGHAI JIAHUA BUSINESS CENTER A8-303, 808, Hongqiao Rd. Shanghai 200030, China  
TEL +86-21-6448-4753 FAX +86-21-6448-3992  
website: [www.iai-robot.com](http://www.iai-robot.com)

## ***IAI Robot (Thailand) Co., Ltd.***

825 PhairojKijja Tower 7th Floor, Debaratana RD., Bangna-Nuea, Bangna, Bangkok 10260, Thailand  
TEL +66-2-361-4458 FAX +66-2-361-4456  
website: [www.iai-robot.co.th](http://www.iai-robot.co.th)