



Quality and Innovation

Simple-to-use ELECYLINDER with Built-in Controller  
Medium Belt-driven Type with Top/Bottom-mounted 24 VDC Pulse Motor

**EC** B6/7S(U)  
B8S(U)

Simple-to-use ELECYLINDER with Built-in Controller  
Medium Belt-driven Type with Top/Bottom-mounted 230 VAC Servo Motor

**EC** B8SS(U)

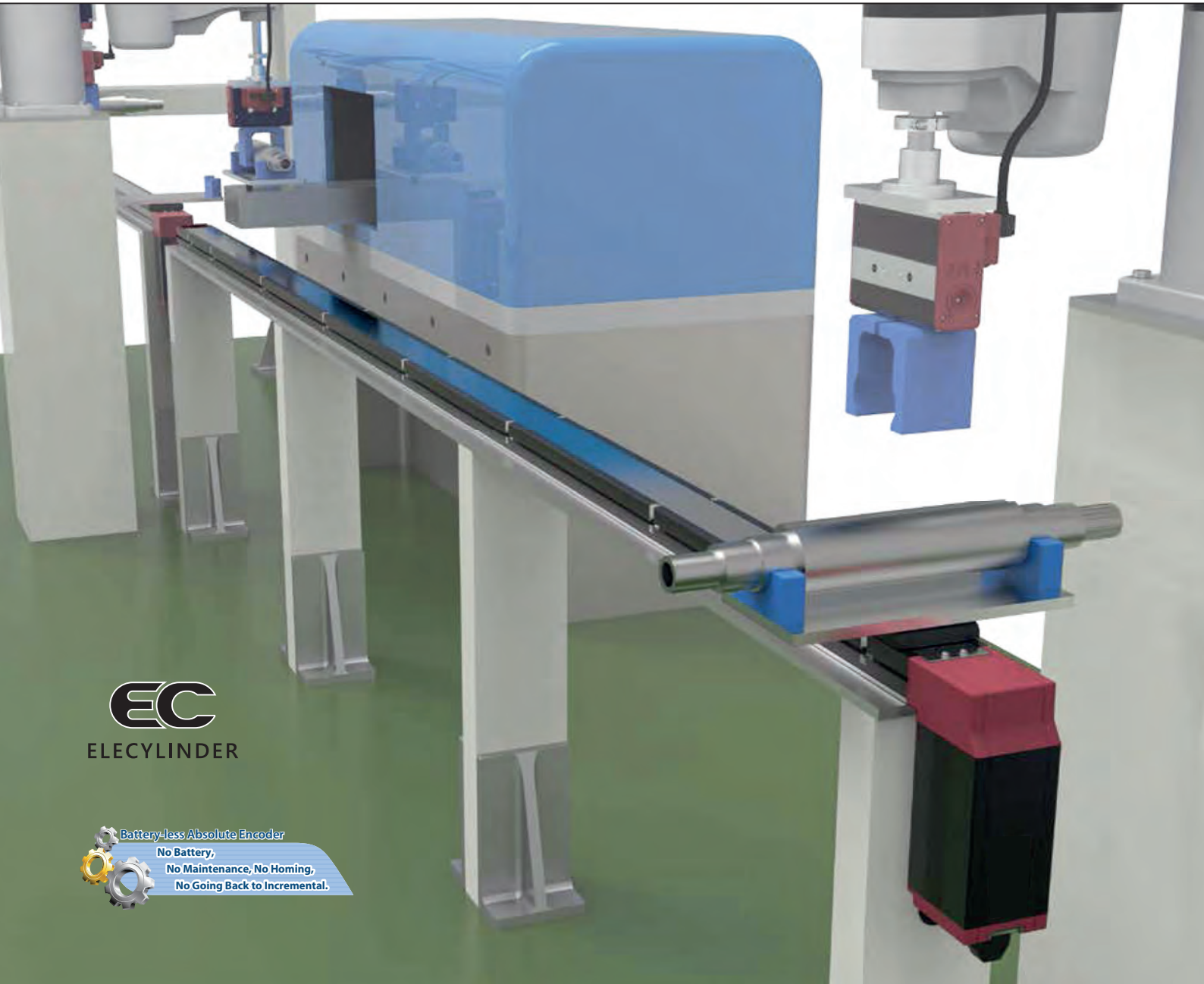

**EC**  
ELECYLINDER

 Battery-less Absolute Encoder  
No Battery,  
No Maintenance, No Homing,  
No Going Back to Incremental.



ELECYLINDER

- Long stroke
- High speed
- High payload
- Low cost
- Easy to operate

# EleCylinder Belt Driven Type



High thrust types are now available!

Type	B6S	B7S	B8S	B8SS
External appearance				
Maximum stroke	2600mm	2600mm	2600mm	2600mm
Maximum payload	11kg	20kg	25kg	15kg
Maximum speed	1500mm/s	1600mm/s	1800mm/s	2000mm/s

## Point Payload and speed



Point



**For high payloads at lower speeds**

Choose models equipped with a pulse motor (B6S, B7S, B8S)



**For high payloads at higher speeds**

Choose models equipped with a servo motor (B8SS)

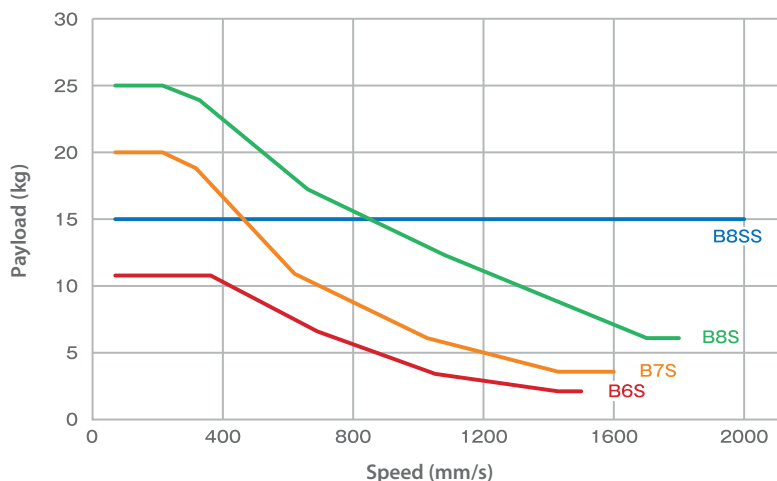

## Best suited for long-distance transfers between processes

There are no slowdowns due to stroke lengths.

### Stroke and speed

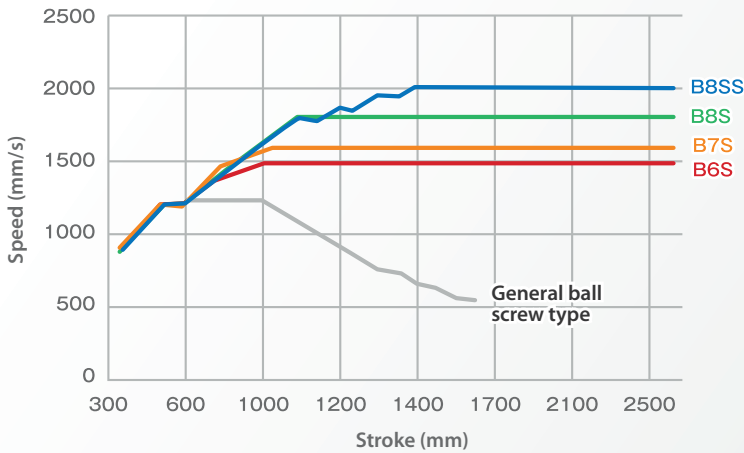

Further more...

### Shortened startup time

By selecting a battery-less absolute encoder, the home return becomes unnecessary. (Equipped standard in B8SS)

#### » In case of incremental:

Position motion can only begin after returning to the mechanical end at a low speed.

#### » In case of battery-less absolute:

Position motion begins immediately from wherever the actuator stopped.

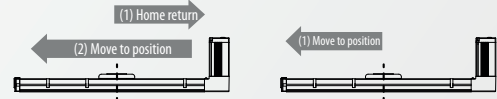

Thanks to the built-in mechanical position detecting device, using a battery to backup the position data is also unnecessary.



### Point

Operating time and cycle time can be shortened.

## Transferring motor shafts between processes

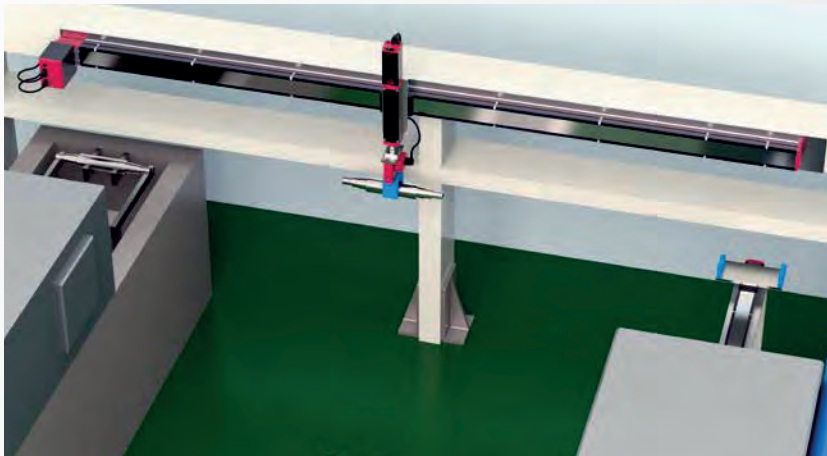

The side-mounted EC-B8SS is used to transfer parts between machine tools.

High speed transfer at 2000mm/s is possible.

[Click here to view the demo video](#)



Belt driven type  
EleCylinder product page of IAI America

## Easy yet accurate adjustments are possible.

Once setting is complete, it continues to operate in the same parameters.



Feedback control  
Position: 1000 times/s  
Speed: up to 20000 times/s

Units for setting parameters  
Position: 0.01mm  
Speed: 0.01mm/s



### Point

Has a built-in controller and encoder.

### Easy teaching with a wireless controller



With a wireless connection, operations from remote locations are possible (guideline: 5m)

### Functions of the wireless teaching controller

- Basic setting (position, acceleration, speed, deceleration)
- Retrieving current location data
- Cycle time checking
- Alarm reset
- Error Display

Available specifically with the WL2 option:

- \* Trial operation
- \* Jog motion
- \* Motor power ON/OFF
- \* Brake Release

**EleCylinder Belt Driven Type [Models equipped with a pulse motor]**

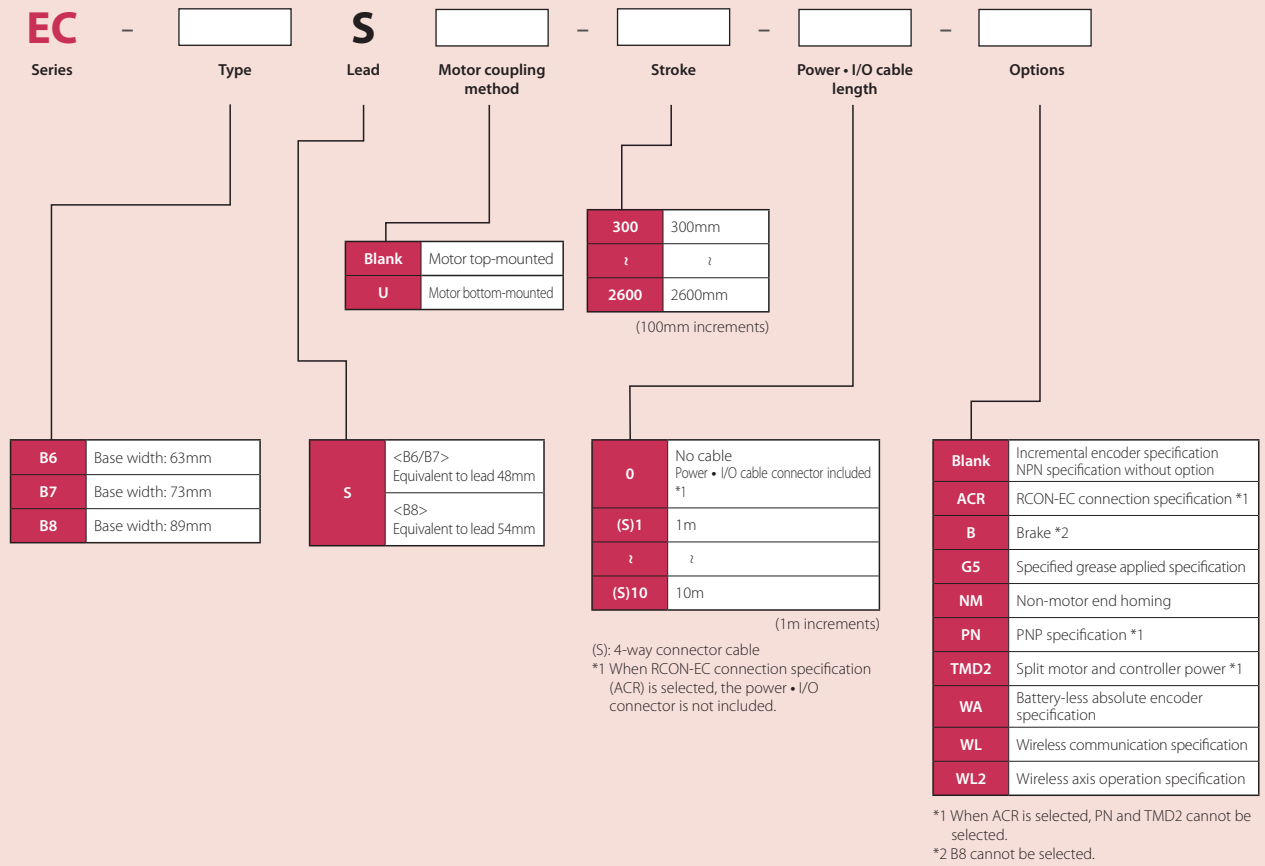

**EleCylinder Belt Driven Type [Models equipped with a 230VAC servo motor]**

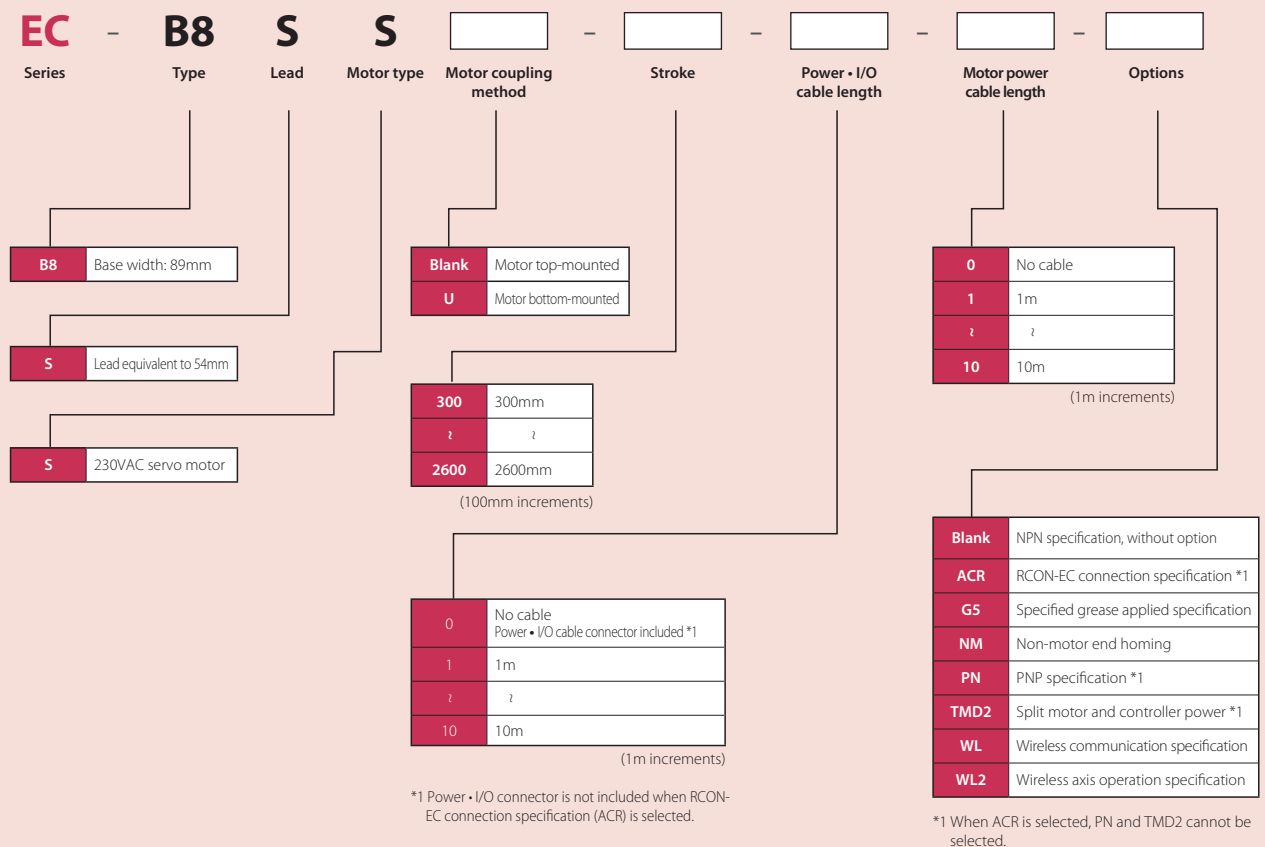
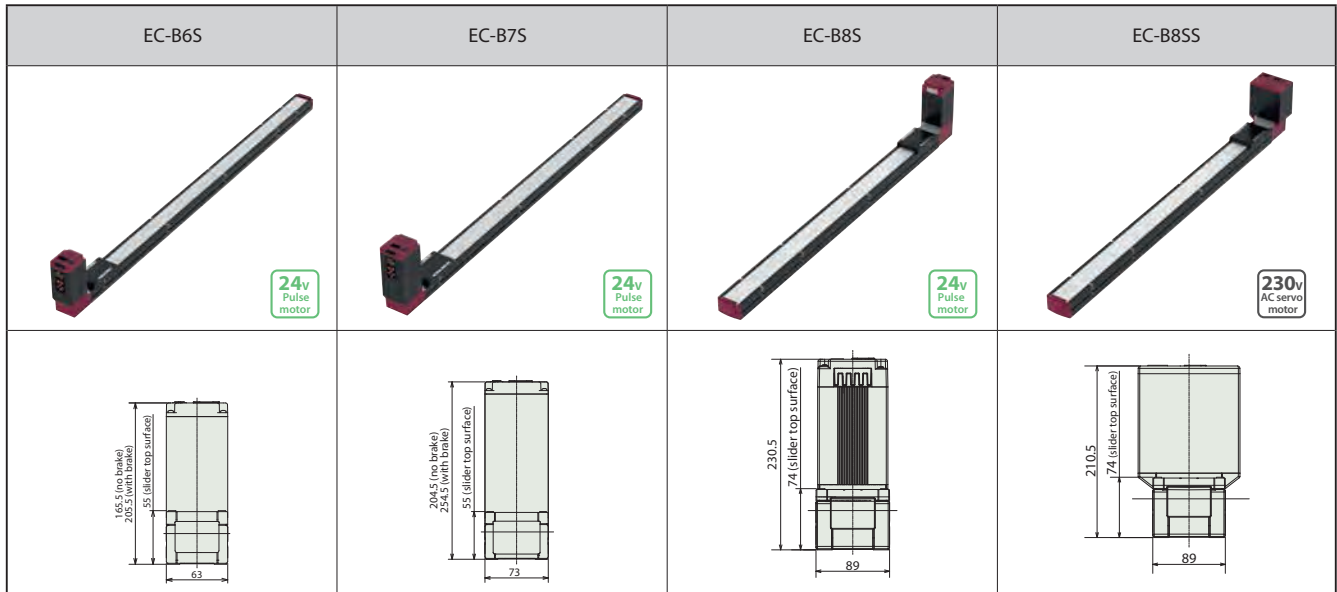

Table of specifications



Motor type	Type	Lead		Stroke (mm) and maximum speed (mm/s)												Maximum payload (kg)	Reference page	
		Model	mm	* Band length = stroke * number in the band = maximum speed by stroke														
				300	400	500	600	700	800	900	1000	1100	1200	1300	1400~2600			
24v Pulse motor	B6	S	Equivalent to 48	890	1070	1220	1340	1400	1440	1500						11	P7	
	B7	S	Equivalent to 48	890	1070	1220	1340	1450	1520	1550	1600						20	P10
	B8	S	Equivalent to 54	1040	1270	1440	1560	1640	1690	1730	1750	1770	1780	1790	1800	25	P13	
230v AC servo motor (200W)	B8	SS	Equivalent to 54	1210	1460	1670	1800	1890	1930	1960	1980	1990	2000			15	P16	

Energy-saving setting

EC-B6/B7 can select enabled/disabled of the "Energy-saving setting" at parameter (No. 8). \* The B8 is not compatible with energy saving mode. Enabling this setting reduces power capacity by about 40% compared when the setting is disabled. The max. speed, max. acceleration/ deceleration and payload decrease compared to when the setting is disabled. Disabling the setting increases max. speed, max. acceleration/ deceleration and payload compared to when the setting is enabled. Refer to the "Payload Table by Speed and Acceleration" and "Stroke and max. Speed" tables on each product's specification page. The product is set to disabled by default.

Mode	Parameter name / display	Features
Power mode	Energy-saving setting disabled	High specification
Energy-saving mode	Energy-saving setting enabled	High energy-saving effect



Automatic servo OFF function

The "Automatic Servo OFF Function" can be set using the PC-compatible teaching software or the teaching pendant (TB-02/03). When the automatic servo OFF function is set, the servo will automatically be turned OFF after a certain time upon completion of a position or when the actuator is stopped. When the next move command is input, servo will be turned ON automatically and execute a positioning motion. When stopped, there is no holding current, which reduces power consumption.

**Mounting orientation**

○ : Mounting possible — : Mounting impossible

Mounting orientation			
Horizontal mounting on flat surface	Horizontal side mount	Horizontal ceiling mount	Vertical mount
○	○*1	○*1	—

\*1: Installing the product horizontal side mount or horizontal ceiling mount may cause slack or misalignment in the stainless steel sheet. Continued use in these orientations can cause the stainless steel sheet to break. Check it daily and adjust the sheet if any slack or misalignment is found.

**Precautions on Installation**

- Flatness of the main body mounting surface and workpiece mounting surface should be 0.05mm/m or smaller. Inadequate flatness increases sliding friction, causing malfunction.
- The base bottom and left surfaces (seen from the opposite side of the motor) of the main body are the reference surface for the slider's travel accuracy. If travel accuracy is needed, install the product based on the respective surface as the reference.

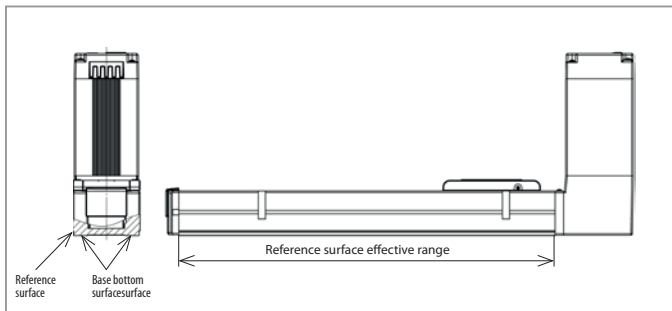

When mounting using the side surfaces as a reference, the machining of the mounting surfaces should be done according to the drawing below.

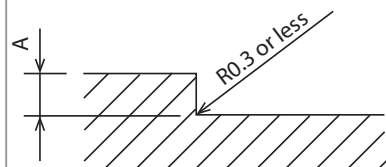

Type	A dimension (mm)
B6/B7/B8	2~5

**Overhang load length**

This is the allowable offset length of the payload when the payload is not centered on the slider. If the overhang length exceeds the allowable offset length in any direction, excessive vibration or other mechanical failures can occur. To ensure smooth operation, please use the products within their allowable overhang values.

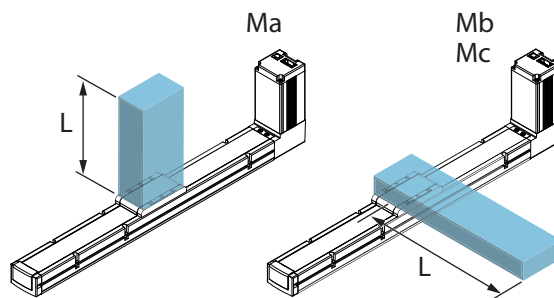

Mounting method

■ Mounting the actuator base

The actuator has through holes for mounting from the top.

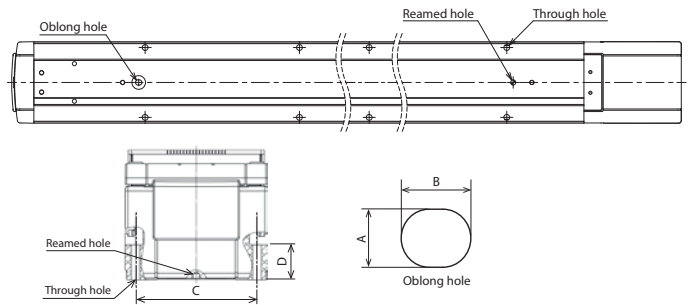
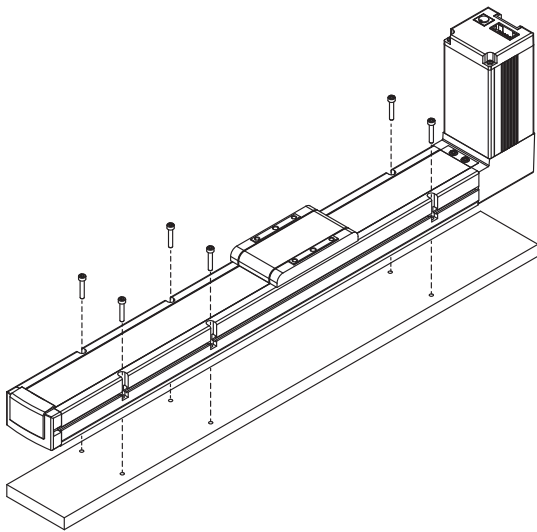

Type	Through hole diameter [mm]	Through hole width C[mm]	Through hole depth D[mm]	Reamed hole [mm]	Oblong hole [mm]
B6	ø4.5	54	13	ø4H7 depth 4	A: 4 <sup>+0.012</sup> B: 5 depth 4
B7	ø5.5	63	12		
B8	ø5.5	76	22		

<Precautions>

- \* Basically, use all the through holes to support the entire surface.
- \* If travel accuracy is not needed, securing the base using only foot brackets is also possible. In these cases, all through holes still must be used to provide proper support.
- \* Do not mount the base only at the ends.  
The base may warp and sliding resistance increases at both ends.

Entire surface to be fixed All the through holes to be used	To be fixed with foot brackets, etc. All the through holes to be used	Fixed only at the both ends
✓ 	✓ 	✗ 

■ Mounting to the slider

Mount the payload using the screw holes on the slider top surface.

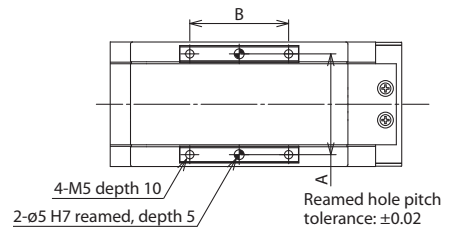
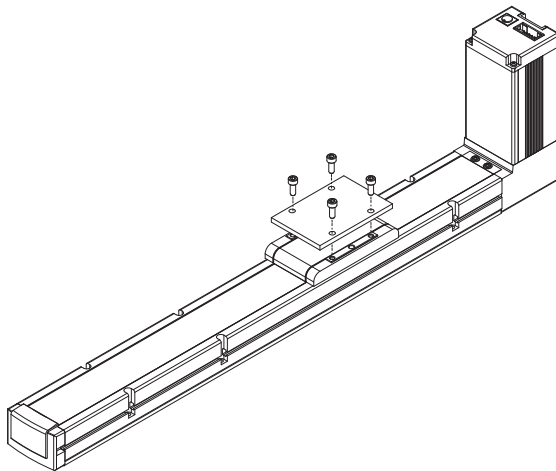

Type	A [mm]	B [mm]
B6	51	50
B7	61	50
B8	76	50

<Precautions>

In case of the motor top-mounted specification, the motor (motor cover) extrudes from the top surface. Make sure the payload will not collide with the motor.

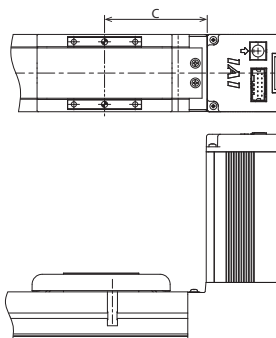

Distance between the slider center and the motor cover at the mechanical end: C

Type	C [mm]
B6	78.7
B7	87.7
B8	89

# EC-B6S

# EC-B6SU

Simple Dust Proof

Belt Type

Motor Unit Coupled

Body width 63 mm

24v Pulse motor

Model Specification Items

EC - B6 S [ ] - [ ] - [ ] - [ ]

Series	Type	Lead	Specification		Stroke	Power · I/O cable length	Option
Standard	S	48mm	Blank	Motor top-mounted	300 ? 2600	0 Terminal block type with connector	Refer to options below
			U	Motor bottom-mounted	300mm ? 2600mm (100mm increments)	(S)1 1m ? (S)10 10m	

Code "S" for 4-way cable, see cable length table below.

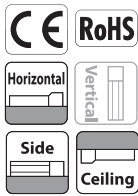

(Note) The above is motor top-mounted type.

- POINT  
Selection  
Notes

  - (1) The belt type may cause vibration or noise during low-speed operation, so set the moving speed to 100mm/s or more.
  - (2) The actuator specifications display the payload's maximum value. Please refer to "Table of Payload by Speed/ Acceleration" for more details.
  - (3) Push-motion operation cannot be performed.
  - (4) Special attention needs to be paid to the mounting orientation. Refer to P5 for details.
  - (5) Reference value of the overhang load length is under 220mm in the Ma, Mb and Mc directions. Refer to P5 for the overhang load length.
  - (6) The center of gravity of the attached object should be less than 1/2 of the overhang distance. Even when the overhang distance and load moment are within the allowable range, the operating conditions should be moderated if some abnormal vibration or noise is observed.

### Power · I/O cable length

Standard connector cable

Cable code	Cable length	User wiring specification (no connector)	RCON-EC connection specification (with connectors on both sides) (Note 1)
0	Without cable (with connector)	Only a terminal block connector is included	CB-REC-PWBIO□□□-RB included (Note 2)
1 ~ 3	1 ~ 3m	CB-EC-PWBIO□□□-RB included (Note 2)	
4 ~ 5	4 ~ 5m		
6 ~ 7	6 ~ 7m		
8 ~ 10	8 ~ 10m		

(Note 1) When optional RCON-EC connection spec. (ACR) is selected.  
 (Note 2) Robot cable.

4-directional connector cable

Cable code	Cable length	User wiring specification (no connector)	RCON-EC connection specification (with connectors on both sides) (Note 1)
S1 ~ S3	1 ~ 3m	CB-EC2-PWBIO□□□-RB included (Note 2)	CB-REC2-PWBIO□□□-RB included (Note 2)
S4 ~ S5	4 ~ 5m		
S6 ~ S7	6 ~ 7m		
S8 ~ S10	8 ~ 10m		

(Note 1) When optional RCON-EC connection spec. (ACR) is selected.  
 (Note 2) Robot cable.

### Options

Name	Option code	Reference page
RCON-EC connection specification (Note 1)	<b>ACR</b>	19
Brake	<b>B</b>	19
Specified grease applied specification (Note 2)	<b>G5</b>	19
Non-motor end specification	<b>NM</b>	19
PNP specification	<b>PN</b>	19
Twin power supply specification	<b>TMD2</b>	19
Battery-less absolute encoder specification	<b>WA</b>	19
Wireless communication specification	<b>WL</b>	19
Wireless axis operation specification	<b>WL2</b>	19

(Note 1) When selecting RCON-EC connection specification (ACR), PNP specification (PN) and twin power source specification (TMD2) cannot be selected.  
 (Note 2) Change grease to food grade.

Main Specifications

Item		Description	
Horizontal	Payload	Maximum payload (energy-saving disabled) (kg)	11
		Maximum payload (energy-saving enabled) (kg)	3
	Speed/acceleration/deceleration	Max. speed (mm/s)	1500
		Min. speed (mm/s)	100
		Rated acceleration/deceleration (G)	0.3
Brake	Max. acceleration/deceleration (G)	1.0	
	Brake holding specification	Non-excitation actuating solenoid brake	
Stroke	Brake holding force (kgf)	1.3	
	Min. stroke (mm)	300	
	Max. stroke (mm)	2600	
	Stroke pitch (mm)	100	

Item	Description
Driving system	Timing belt 9mm width 3mm pitch 48mm lead
Positioning repeatability	±0.08mm
Base	Dedicated aluminum extruded material (A6063SS-T5 Equivalent) Black alumite treatment
Linear guide	Linear motion infinite circulating type
Static allowable moment	Ma: 48.5 N·m
	Mb: 69.3 N·m
	Mc: 97.1 N·m
Dynamic allowable moment (Note 1)	Ma: 11.6 N·m
	Mb: 16.6 N·m
	Mc: 23.3 N·m
Ambient operation temperature/humidity	0~40°C, 85%RH or less (Non-condensing)
Degree of protection	IP20
Vibration & shock resistance	4.9m/s <sup>2</sup>
Overseas standards	CE marking, RoHS (Restriction of Hazardous Substances)
Motor type	Pulse motor (□42) (Power capacity: max. 4.2A)
Encoder type	Incremental / battery-less absolute
Number of encoder pulses	800 pulse/rev

■ Direction of moment for the Slider type

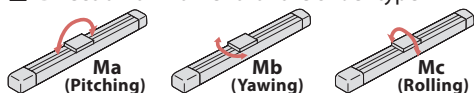

(Note 1) Based on the standard rated operation life of 5000 km. Operation life varies according to operating and mounting conditions.

Table of Payload by Speed and Acceleration/Deceleration \*Energy-saving setting disabled at shipping. Refer to P. 4 for details.

■ Energy-saving disabled The unit for payload is kg.

Orientation	Horizontal			
	Acceleration (G)			
Speed (mm/s)	0.3	0.5	0.7	1
0	11	10	8	7
200	11	10	8	7
300	11	8.5	7	6
600	7	5	4	3
1000	4	3	2	1
1200	3	2	1	0.5
1400	2	1	1	0.5
1500	2	1	1	0.5

■ Energy-saving enabled The unit for payload is kg.

Orientation	Horizontal	
	Acceleration (G)	
Speed (mm/s)	0.3	0.7
0	3	2
800	3	2
1400	0.5	0.5

Stroke and maximum speed

Energy saving	300 (mm)	400 (mm)	500 (mm)	600 (mm)	700 (mm)	800 (mm)	900~2600 (per 100mm)
Disabled	890	1070	1220	1340	1400	1440	1500
Enabled	890	1070	1220	1300	1350	1400	

(Unit is mm/s)

ST: Stroke  
M.E.: Mechanical end  
S.E.: Stroke end

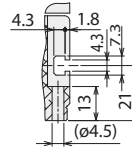
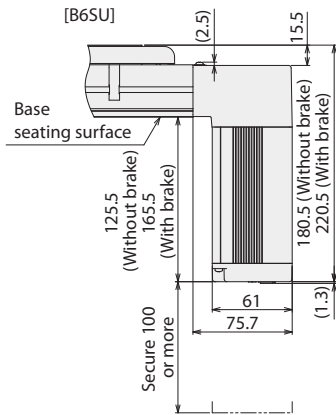
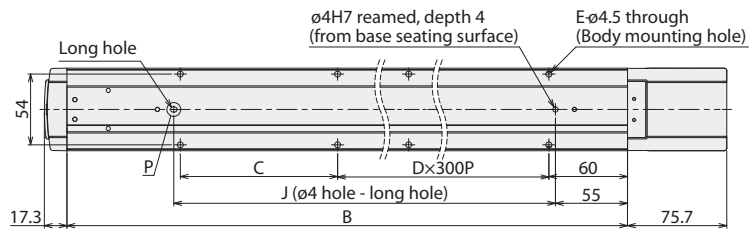
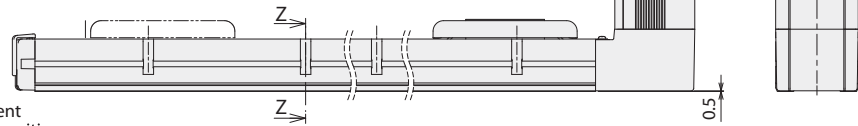
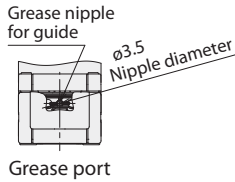
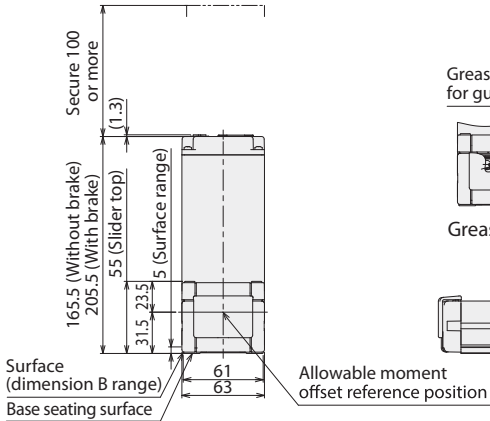
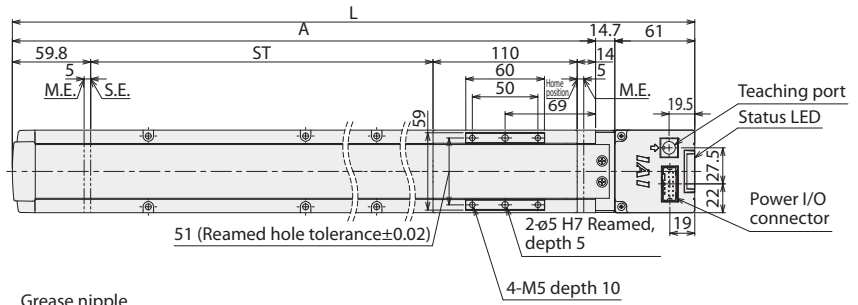

Sectional view Z-Z  
Detail of through hole  
for attaching the base  
Base mounting hole  
Details of T slot

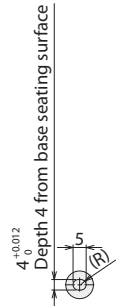

Detailed drawing P  
base long hole detail

■ Dimensions by stroke

Stroke	300	400	500	600	700	800	900	1000	1100	1200	1300	1400	1500	1600	1700	1800	1900	2000	2100	2200	2300	2400	2500	2600
L	559.5	659.5	759.5	859.5	959.5	1059.5	1159.5	1259.5	1359.5	1459.5	1559.5	1659.5	1759.5	1859.5	1959.5	2059.5	2159.5	2259.5	2359.5	2459.5	2559.5	2659.5	2759.5	2859.5
A	483.8	583.8	683.8	783.8	883.8	983.8	1083.8	1183.8	1283.8	1383.8	1483.8	1583.8	1683.8	1783.8	1883.8	1983.8	2083.8	2183.8	2283.8	2383.8	2483.8	2583.8	2683.8	2783.8
B	466.5	566.5	666.5	766.5	866.5	966.5	1066.5	1166.5	1266.5	1366.5	1466.5	1566.5	1666.5	1766.5	1866.5	1966.5	2066.5	2166.5	2266.5	2366.5	2466.5	2566.5	2666.5	2766.5
C	320	120	220	320	120	220	320	120	220	320	120	220	320	120	220	320	120	220	320	120	220	320	120	220
D	0	1	1	1	2	2	2	3	3	3	4	4	4	5	5	5	6	6	6	7	7	7	8	8
E	4	6	6	6	8	8	8	10	10	10	12	12	12	14	14	14	16	16	16	18	18	18	20	20
J	330	430	530	630	730	830	930	1030	1130	1230	1330	1430	1530	1630	1730	1830	1930	2030	2130	2230	2330	2430	2530	2630

■ Mass by stroke

Weight (kg)	Stroke	300	400	500	600	700	800	900	1000	1100	1200	1300	1400	1500	1600	1700	1800	1900	2000	2100	2200	2300	2400	2500	2600
	W/o Brake	2.7	3.0	3.4	3.7	4.0	4.3	4.7	5.0	5.3	5.6	5.9	6.3	6.6	6.9	7.2	7.5	7.8	8.2	8.5	8.8	9.2	9.5	9.8	10.2
With Brake	3.0	3.3	3.7	4.0	4.3	4.6	5.0	5.3	5.6	5.9	6.2	6.6	6.9	7.2	7.5	7.8	8.1	8.5	8.8	9.1	9.5	9.8	10.1	10.5	

Note: B6SU also has the same mass.

Applicable controller

(Note) The EC series is equipped with a built-in controller. Refer to P23 for the details of the built-in controller.

# EC-B7S

# EC-B7SU

Simple Dust Proof	Belt Type	Motor Unit Coupled	Body width 73 mm	24v Pulse motor
-------------------	-----------	--------------------	------------------	-----------------

Model Specification Items

EC - B7 S

Series	Type	Lead	Blank	Specification	Stroke	Power · I/O cable length	Option
	Standard S	48mm	Blank	Motor top-mounted	300 ? 2600	Terminal block type with connector	Refer to option below
			U	Motor bottom-mounted	300mm ? 2600mm (100mm increments)	0	
						(S)1	
						?	
						(S)10	
						1m	
						?	
						10m	

Code "S" for 4-way cable, see cable length table below.

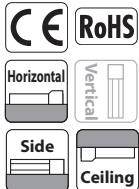

(Note) The above is motor top-mounted type.

- POINT Selection Notes**
- (1) The belt type may cause vibration or noise during low-speed operation, so set the moving speed to 100mm/s or more.
  - (2) The actuator specifications display the payload's maximum value. Please refer to "Table of Payload by Speed/ Acceleration" for more details.
  - (3) Push-motion operation cannot be performed.
  - (4) Special attention needs to be paid to the mounting orientation. Refer to P5 for details.
  - (5) Reference value of the overhang load length is under 280mm in the Ma, Mb and Mc directions. Refer to P5 for the overhang load length.
  - (6) The center of gravity of the attached object should be less than 1/2 of the overhang distance. Even when the overhang distance and load moment are within the allowable range, the operating conditions should be moderated if some abnormal vibration or noise is observed.

## Power · I/O cable length

### Standard connector cable

Cable code	Cable length	User wiring specification (no connector)	RCON-EC connection specification (with connectors on both sides) (Note 1)
0	Without cable (with connector)	Only a terminal block connector is included	CB-REC-PWBIO□□□-RB included (Note 2)
1 ~ 3	1 ~ 3m	CB-EC-PWBIO□□□-RB included (Note 2)	
4 ~ 5	4 ~ 5m		
6 ~ 7	6 ~ 7m		
8 ~ 10	8 ~ 10m		

(Note 1) When optional RCON-EC connection spec. (ACR) is selected.  
(Note 2) Robot cable.

### 4-directional connector cable

Cable code	Cable length	User wiring specification (no connector)	RCON-EC connection specification (with connectors on both sides) (Note 1)
S1 ~ S3	1 ~ 3m	CB-EC2-PWBIO□□□-RB included (Note 2)	CB-REC2-PWBIO□□□-RB included (Note 2)
S4 ~ S5	4 ~ 5m		
S6 ~ S7	6 ~ 7m		
S8 ~ S10	8 ~ 10m		

(Note 1) When optional RCON-EC connection spec. (ACR) is selected.  
(Note 2) Robot cable.

## Options

Name	Option code	Reference page
RCON-EC connection specification (Note 1)	<b>ACR</b>	19
Brake	<b>B</b>	19
Specified grease applied specification (Note 2)	<b>G5</b>	19
Non-motor end specification	<b>NM</b>	19
PNP specification	<b>PN</b>	19
Twin power supply specification	<b>TMD2</b>	19
Battery-less absolute encoder specification	<b>WA</b>	19
Wireless communication specification	<b>WL</b>	19
Wireless axis operation specification	<b>WL2</b>	19

(Note 1) When selecting RCON-EC connection specification (ACR), PNP specification (PN) and twin power source specification (TMD2) cannot be selected.  
(Note 2) Change grease to food grade.

**Main Specifications**

Item		Description	
Horizontal	Payload	Maximum payload (energy-saving disabled) (kg)	20
		Maximum payload (energy-saving enabled) (kg)	14
	Speed/acceleration/deceleration	Max. speed (mm/s)	1600
		Min. speed (mm/s)	100
		Rated acceleration/deceleration (G)	0.3
		Max. acceleration/deceleration (G)	1.0
Brake	Brake holding specification	Non-excitation actuating solenoid brake	
	Brake holding force (kgf)	2.5	
Stroke	Min. stroke (mm)	300	
	Max. stroke (mm)	2600	
	Stroke pitch (mm)	100	

Item	Description
Driving system	Timing belt 9mm width 3mm pitch 48mm lead
Positioning repeatability	±0.08mm
Base	Dedicated aluminum extruded material (A6063SS-T5 Equivalent) Black alumite treatment
Linear guide	Linear motion infinite circulating type
Static allowable moment	Ma: 79.7 N·m
	Mb: 114 N·m
	Mc: 157 N·m
Dynamic allowable moment (Note 1)	Ma: 17.7 N·m
	Mb: 25.3 N·m
	Mc: 34.9 N·m
Ambient operation temperature/humidity	0~40°C, 85%RH or less (Non-condensing)
Degree of protection	IP20
Vibration & shock resistance	4.9m/s <sup>2</sup>
Overseas standards	CE marking, RoHS (Restriction of Hazardous Substances)
Motor type	Pulse motor (□56) (Power capacity: max. 4.2A)
Encoder type	Incremental / battery-less absolute
Number of encoder pulses	800 pulse/rev

■ Direction of moment for the Slider type

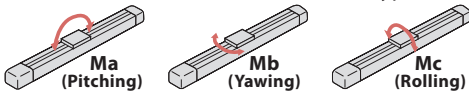

(Note 1) Based on the standard rated operation life of 5000 km. Operation life varies according to operating and mounting conditions.

**Table of Payload by Speed and Acceleration/Deceleration** \*Energy-saving setting disabled at shipping. Refer to P. 4 for details.

■ Energy-saving disabled The unit for payload is kg.

Orientation	Horizontal			
	Acceleration (G)			
Speed (mm/s)	0.3	0.5	0.7	1
0	20	20	18	16
100	20	20	18	16
200	20	20	17	15
300	19	17	15	13
600	11	9	8	7
1000	6	5	4	3
1400	3	2	1	0.5
1600	3	2	1	0.5

■ Energy-saving enabled The unit for payload is kg.

Orientation	Horizontal	
	Acceleration (G)	
Speed (mm/s)	0.3	0.7
0	14	12
100	14	12
400	10	8
800	5	3
1200	1	0.5

**Stroke and maximum speed**

Energy saving	300 (mm)	400 (mm)	500 (mm)	600 (mm)	700 (mm)	800 (mm)	900 (mm)	1000~2600 (per 100mm)
Disabled	890	1070	1220	1340	1450	1520	1550	1600
Enabled	890	1070	1120	1200				

(Unit is mm/s)



# EC-B8S

# EC-B8SU

Simple  
Dust Proof

Belt  
Type

Motor  
Unit  
Coupled

Body width  
**89**  
mm

**24v**  
Pulse  
motor

■ Model Specification Items

EC — B8 S [ ] — [ ] — [ ] — [ ]

Series	Type	Lead	Specification		Stroke	Power · I/O cable length	Option
Standard	S	54mm	Blank	Motor top-mounted	300 ? 2600	Terminal block type with connector	Refer to options below
			U	Motor bottom-mounted	300mm ? 2600mm (100mm increments)	0	
						(S)1	1m
						(S)10	10m

Code "S" for 4-way cable, see cable length table below.



(Note) The above is motor top-mounted type.

- POINT  
Selection  
Notes

  - (1) The belt type may cause vibration or noise during low-speed operation, so set the moving speed to 100mm/s or more.
  - (2) The actuator specifications display the payload's maximum value. Please refer to "Table of Payload by Speed/ Acceleration" for more details.
  - (3) Push-motion operation cannot be performed.
  - (4) Special attention needs to be paid to the mounting orientation. Refer to P5 for details.
  - (5) Reference value of the overhang load length is under 320mm in the Ma, Mb and Mc directions. Refer to P5 for the overhang load length.
  - (6) The center of gravity of the attached object should be less than 1/2 of the overhand distance. Even when the overhang distance and load moment are within the allowable range, the operating conditions should be moderated if some abnormal vibration or noise is observed.
  - (7) When connecting to the RCON-EC, there is a limit to the number of connectable axes. Please contact IAI for details.

### Power · I/O cable length

■ Standard connector cable

Cable code	Cable length	User wiring specification (no connector)	RCON-EC connection specification (with connectors on both sides) (Note 1)
0	Without cable (with connector)	Only a terminal block connector is included	CB-REC-PWBIO□□□-RB included (Note 2)
1 ~ 3	1 ~ 3m	CB-EC-PWBIO□□□-RB included (Note 2)	
4 ~ 5	4 ~ 5m		
6 ~ 7	6 ~ 7m		
8 ~ 10	8 ~ 10m		

(Note 1) When optional RCON-EC connection spec. (ACR) is selected.  
(Note 2) Robot cable.

■ 4-directional connector cable

Cable code	Cable length	User wiring specification (no connector)	RCON-EC connection specification (with connectors on both sides) (Note 1)
S1 ~ S3	1 ~ 3m	CB-EC2-PWBIO□□□-RB included (Note 2)	CB-REC2-PWBIO□□□-RB included (Note 2)
S4 ~ S5	4 ~ 5m		
S6 ~ S7	6 ~ 7m		
S8 ~ S10	8 ~ 10m		

(Note 1) When optional RCON-EC connection spec. (ACR) is selected.  
(Note 2) Robot cable.

### Options

Name	Option code	Reference page
RCON-EC connection specification (Note 1)	<b>ACR</b>	19
—	—	—
Specified grease applied specification (Note 2)	<b>G5</b>	19
Non-motor end specification	<b>NM</b>	19
PNP specification	<b>PN</b>	19
Twin power supply specification	<b>TMD2</b>	19
Battery-less absolute encoder specification	<b>WA</b>	19
Wireless communication specification	<b>WL</b>	19
Wireless axis operation specification	<b>WL2</b>	19

(Note 1) When selecting RCON-EC connection specification (ACR), PNP specification (PN) and twin power source specification (TMD2) cannot be selected.  
(Note 2) Change grease to food grade.

Main Specifications

Item		Description	
Horizontal	Payload	Maximum payload (kg)	25
		—	—
	Speed/ acceleration/ deceleration	Max. speed (mm/s)	1800
		Min. speed (mm/s)	100
		Rated acceleration/ deceleration (G)	0.3
Brake	Max. acceleration/ deceleration (G)	1.0	
	Brake holding specification	—	
Stroke	Brake holding force (kgf)	—	
	Min. stroke (mm)	300	
	Max. stroke (mm)	2600	
	Stroke pitch (mm)	100	

Item	Description
Driving system	Timing belt 15mm width 3mm pitch 54mm lead
Positioning repeatability	±0.08mm
Base	Dedicated aluminum extruded material (A6063SS-T6 Equivalent) Black alumite treatment
Linear guide	Linear motion infinite circulating type
Static allowable moment	Ma: 191 N•m
	Mb: 191 N•m
	Mc: 397 N•m
Dynamic allowable moment (Note 1)	Ma: 38.6 N•m
	Mb: 38.6 N•m
	Mc: 80.2 N•m
Ambient operation temperature/humidity	0~40°C, 85%RH or less (Non-condensing)
Degree of protection	IP20
Vibration & shock resistance	4.9m/s <sup>2</sup>
Overseas standards	CE marking, RoHS (Restriction of Hazardous Substances)
Motor type	Pulse motor (□56SP) (Power capacity: max. 6A)
Encoder type	Incremental / battery-less absolute
Number of encoder pulses	800 pulse/rev

■ Direction of moment for the Slider type

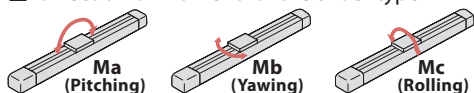

(Note 1) Based on the standard rated operation life of 5000 km. Operation life varies according to operating and mounting conditions.

Table of Payload by Speed and Acceleration/Deceleration

The unit for payload is kg.

Orientation	Horizontal			
	Acceleration (G)			
Speed (mm/s)	0.3	0.5	0.7	1
0	25	25	23	20
100	25	25	23	20
200	25	25	22	19
300	24	22	19	17
600	18	12	10	9
1000	12	7	5	4
1400	8	4	2	1
1600	6	3	2	1
1800	6	3	2	1

Stroke and maximum speed

Stroke (mm)	300 (mm)	400 (mm)	500 (mm)	600 (mm)	700 (mm)	800 (mm)	900 (mm)	1000 (mm)	1100 (mm)	1200 (mm)	1300 (mm)	1400~2600 (per 100mm)
Speed	1040	1270	1440	1560	1640	1690	1730	1750	1770	1780	1790	1800

(Unit is mm/s)

ST: Stroke  
M.E.: Mechanical end  
S.E.: Stroke end

CAD drawings can be downloaded from our website.  
[www.iai-automation.com](http://www.iai-automation.com)

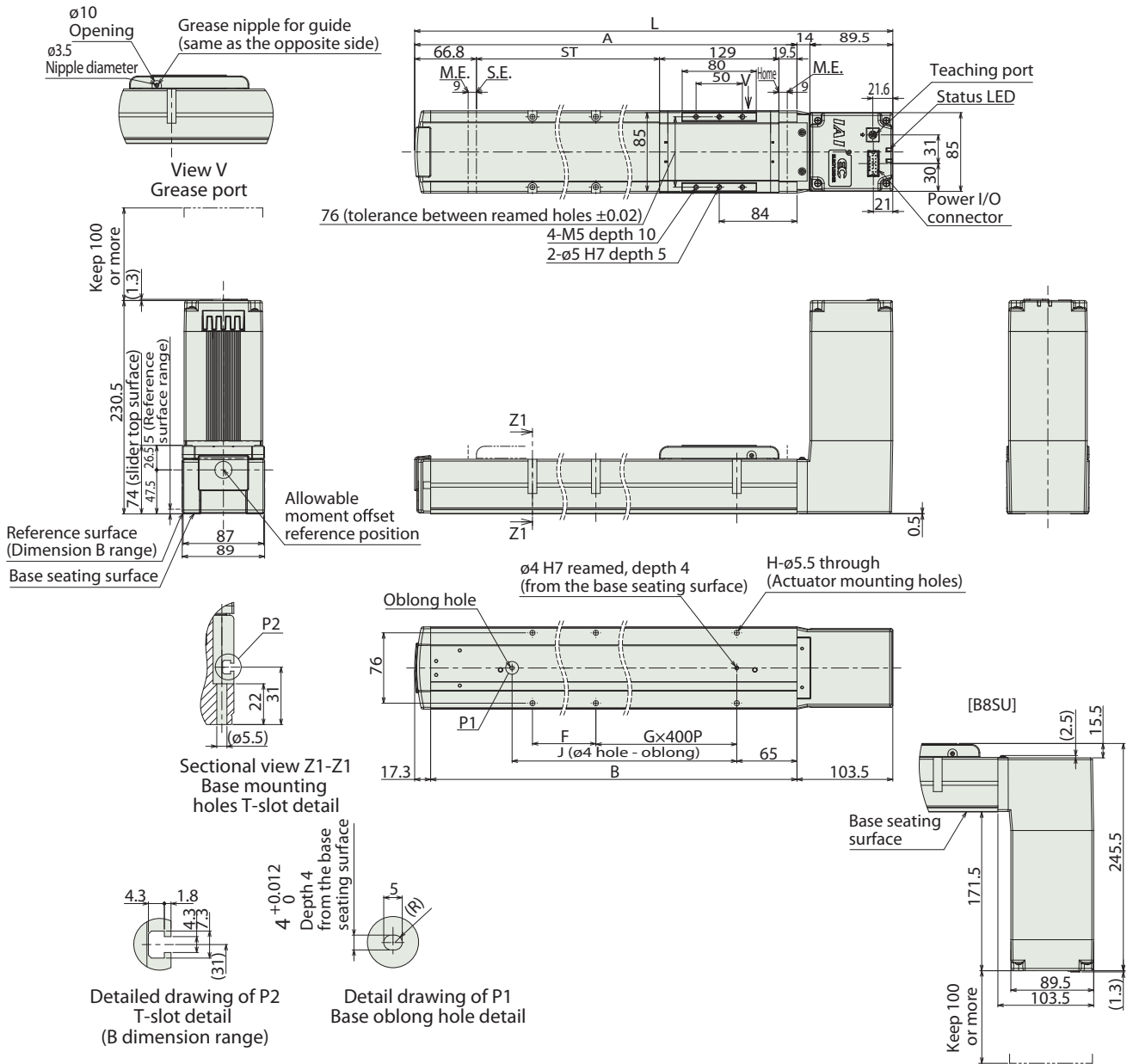

■ Dimensions by stroke

Stroke	300	400	500	600	700	800	900	1000	1100	1200	1300	1400	1500	1600	1700	1800	1900	2000	2100	2200	2300	2400	2500	2600
L	618.8	718.8	818.8	918.8	1018.8	1118.8	1218.8	1318.8	1418.8	1518.8	1618.8	1718.8	1818.8	1918.8	2018.8	2118.8	2218.8	2318.8	2418.8	2518.8	2618.8	2718.8	2818.8	2918.8
A	515.3	615.3	715.3	815.3	915.3	1015.3	1115.3	1215.3	1315.3	1415.3	1515.3	1615.3	1715.3	1815.3	1915.3	2015.3	2115.3	2215.3	2315.3	2415.3	2515.3	2615.3	2715.3	2815.3
B	498	598	698	798	898	998	1098	1198	1298	1398	1498	1598	1698	1798	1898	1998	2098	2198	2298	2398	2498	2598	2698	2798
F	323	423	123	223	323	423	123	223	323	423	123	223	323	423	123	223	323	423	123	223	323	423	123	223
G	0	0	1	1	1	1	2	2	2	2	3	3	3	3	4	4	4	4	5	5	5	5	6	6
H	4	4	6	6	6	6	8	8	8	8	10	10	10	10	12	12	12	12	14	14	14	14	16	16
J	345	445	545	645	745	845	945	1045	1145	1245	1345	1445	1545	1645	1745	1845	1945	2045	2145	2245	2345	2445	2545	2645

■ Mass by stroke

Stroke	300	400	500	600	700	800	900	1000	1100	1200	1300	1400	1500	1600	1700	1800	1900	2000	2100	2200	2300	2400	2500	2600
Weight (kg)	7.4	8.2	9.0	9.7	10.4	11.2	11.9	12.7	13.4	14.2	14.9	15.7	16.4	17.2	17.9	18.7	19.4	20.3	21.0	21.8	22.5	23.3	24.0	24.8

Note: B8SU also has the same mass.

Applicable controller

(Note) The EC series is equipped with a built-in controller. Refer to P23 for the details of the built-in controller.

# EC-B8SS

# EC-B8SSU

Simple Dust Proof | Belt Type | Battery-less Absolute | Motor Unit Coupled | Body width 89 mm | 230v AC servo motor

Model Specification Items

EC - B8 S S

Series	Type	Lead	Motor type	Specification	Stroke	Power • I/O cable length	Motor power cable length	Option	
	S	54mm	S AC servo	Blank U	300 ? 2600	300mm ? 2600mm (100mm increments)	Refer to the Power • I/O cable length below	0 No cable 1 1m ? ? 10 10m	Refer to option below



(Note) The above is motor top-mounted type.

- POINT Selection Notes**
- (1) The actuator specifications display the payload's maximum value. Please refer to "Table of Payload by Speed/ Acceleration" for more details.
  - (2) Push-motion operation cannot be performed.
  - (3) The PSA-200 power unit is required to supply motor power. The PSA-200 can supply power for up to 6 axes. Refer to P28 for details.
  - (4) Special attention needs to be paid to the mounting orientation. Refer to P5 for details.
  - (5) Reference value of the overhang load length is under 320mm in the Ma, Mb and Mc directions. Refer to P5 for the overhang load length.
  - (6) The center of gravity of the attached object should be less than 1/2 of the overhand distance. Even when the overhang distance and load moment are within the allowable range, the operating conditions should be moderated if some abnormal vibration or noise is observed.

### Power • I/O cable length

Cable code	Cable length	User wiring specification (no connector)	RCON-EC connection specification (with connectors on both sides) (Note 1)
0	Without cable (with connector)	Only a terminal block connector is included	CB-REC-PWBIO□□□-RB included (Note 2)
1 ~ 3	1 ~ 3m	CB-EC-PWBIO□□□-RB included (Note 2)	
4 ~ 5	4 ~ 5m		
6 ~ 7	6 ~ 7m		
8 ~ 10	8 ~ 10m		

(Note 1) When optional RCON-EC connection spec. (ACR) is selected.  
(Note 2) Robot cable.

### Motor power cable length

Cable code	Cable length	User wiring / RCON-EC connection specific.
0	No cable	CB-EC-PW□□□-RB included (Note)
1 ~ 3	1 ~ 3m	
4 ~ 5	4 ~ 5m	
6 ~ 10	6 ~ 10m	

(Note) Robot cable.

### Options

Name	Option code	Reference page
RCON-EC connection specification (Note 1)	<b>ACR</b>	19
Specified grease applied specification (Note 2)	<b>G5</b>	19
Non-motor end specification	<b>NM</b>	19
PNP specification	<b>PN</b>	19
Twin power supply specification	<b>TMD2</b>	19
Wireless communication specification	<b>WL</b>	19
Wireless axis operation specification	<b>WL2</b>	19

(Note 1) When selecting RCON-EC connection specification (ACR), PNP specification (PN) and twin power source specification (TMD2) cannot be selected.  
(Note 2) Change grease to food grade.

**Main Specifications**

Item		Description	
Horizontal	Payload	Maximum payload (kg)	15
		—	—
	Speed/ acceleration/ deceleration	Max. speed (mm/s)	2000
		Min. speed (mm/s)	100
		Rated acceleration/ deceleration (G)	0.3
Brake	Max. acceleration/ deceleration (G)	1.0	
	Brake holding specification	—	
Stroke	Brake holding force (kgf)	—	
	Min. stroke (mm)	300	
	Max. stroke (mm)	2600	
	Stroke pitch (mm)	100	

Item	Description
Driving system	Timing belt 15mm width 3mm pitch 54mm lead
Positioning repeatability	±0.04mm
Base	Dedicated aluminum extruded material (A6063SS-T6 Equivalent) Black alumite treatment
Linear guide	Linear motion infinite circulating type
Static allowable moment	Ma: 191 N•m
	Mb: 191 N•m
	Mc: 397 N•m
Dynamic allowable moment (Note 1)	Ma: 38.6 N•m
	Mb: 38.6 N•m
	Mc: 80.2 N•m
Ambient operation temperature/humidity	0~40°C, 85%RH or less (Non-condensing)
Degree of protection	IP20
Vibration & shock resistance	4.9m/s <sup>2</sup>
Overseas standards	CE marking, RoHS (Restriction of Hazardous Substances)
Motor type	AC servo motor (230 V)
Encoder type	Battery-less absolute
Number of encoder pulses	16384 pulse/rev

■ Direction of moment for the Slider type

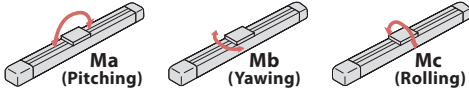

(Note 1) Based on the standard rated operation life of 5000 km. Operation life varies according to operating and mounting conditions.

**Table of Payload by Speed and Acceleration/Deceleration**

The unit for payload is kg.

Orientation	Horizontal			
	Acceleration (G)			
Speed (mm/s)	0.3	0.5	0.7	1
2000	15	9	6	4

**Stroke and maximum speed**

Stroke (mm)	300 (mm)	400 (mm)	500 (mm)	600 (mm)	700 (mm)	800 (mm)	900 (mm)	1000 (mm)	1100 (mm)	1200~2600 (per 100mm)
Speed	1210	1460	1670	1800	1890	1930	1960	1980	1990	2000

(Unit is mm/s)

Dimensions

ST: Stroke  
M.E.: Mechanical end  
S.E.: Stroke end

CAD drawings can be downloaded from our website.  
www.iai-automation.com

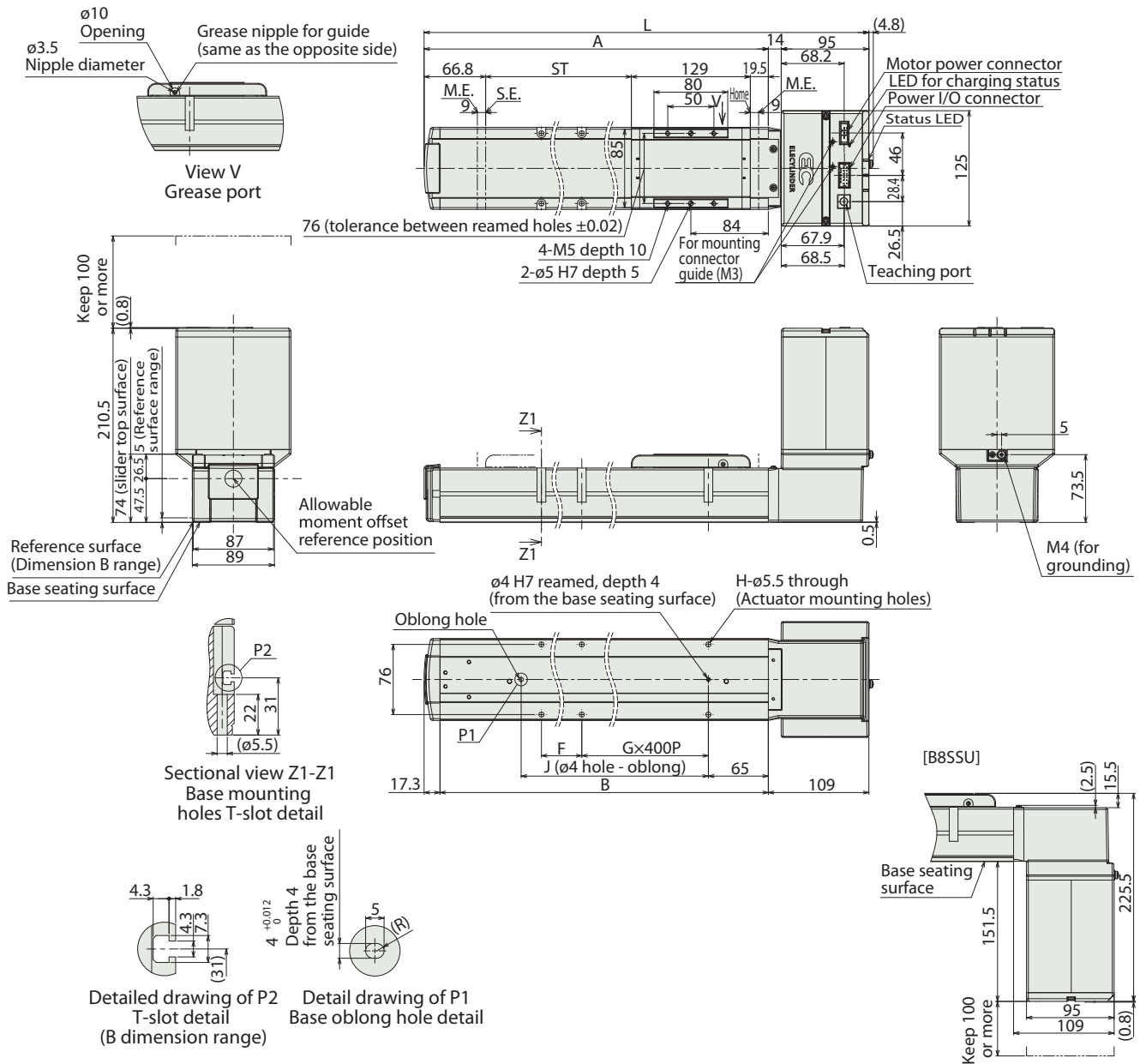

■ Dimensions by stroke

Stroke	300	400	500	600	700	800	900	1000	1100	1200	1300	1400	1500	1600	1700	1800	1900	2000	2100	2200	2300	2400	2500	2600
L	618.8	718.8	818.8	918.8	1018.8	1118.8	1218.8	1318.8	1418.8	1518.8	1618.8	1718.8	1818.8	1918.8	2018.8	2118.8	2218.8	2318.8	2418.8	2518.8	2618.8	2718.8	2818.8	2918.8
A	515.3	615.3	715.3	815.3	915.3	1015.3	1115.3	1215.3	1315.3	1415.3	1515.3	1615.3	1715.3	1815.3	1915.3	2015.3	2115.3	2215.3	2315.3	2415.3	2515.3	2615.3	2715.3	2815.3
B	498	598	698	798	898	998	1098	1198	1298	1398	1498	1598	1698	1798	1898	1998	2098	2198	2298	2398	2498	2598	2698	2798
F	323	423	123	223	323	423	123	223	323	423	123	223	323	423	123	223	323	423	123	223	323	423	123	223
G	0	0	1	1	1	1	2	2	2	2	3	3	3	3	4	4	4	4	5	5	5	5	6	6
H	4	4	6	6	6	6	8	8	8	8	10	10	10	10	12	12	12	12	14	14	14	14	16	16
J	345	445	545	645	745	845	945	1045	1145	1245	1345	1445	1545	1645	1745	1845	1945	2045	2145	2245	2345	2445	2545	2645

■ Mass by stroke

Stroke	300	400	500	600	700	800	900	1000	1100	1200	1300	1400	1500	1600	1700	1800	1900	2000	2100	2200	2300	2400	2500	2600
Weight (kg)	7.3	8.1	8.8	9.6	10.3	11.1	11.8	12.6	13.3	14.1	14.8	15.6	16.3	17.1	17.8	18.6	19.3	20.1	20.9	21.6	22.4	23.1	23.9	24.6

Note: B8SSU also has the same mass.

Applicable controller

(Note) The EC series is equipped with a built-in controller. Refer to P25 for the details of the built-in controller.

EleCylinder driven by 230V power source needs the dedicated DC power unit "PSA-200". Refer to P28 for the details of the "PSA-200."

Options

**RCON-EC connection specification** \*The TMD2 and PN option cannot be selected together (The ACR option includes twin power supply specification)

**Model** **ACR**      **Applicable models** **All models**

**Description** This option is to be selected when connecting a field network via RCON-EC. \* This option automatically splits the motor and controller power. Because the input/output specification is fixed to NPN, the TMD2 and PN options cannot be selected together.

**Brake**

**Model** **B**      **Applicable models** **EC-B6S / B7S**

**Description** This works as a holding mechanism that prevents the slider moving when the power or servo is turned off.

**Specified grease applied specification**

**Model** **G5**      **Applicable models** **All models**

**Description** The grease put on the ball screw, linear guide and rod, is changed to food grade grease (White Alcom).

**Non-motor end homing specification**

**Model** **NM**      **Applicable models** **All models**

**Description** The home position is normally set to the motor side. This option is for setting the home position on the other side in order to accommodate variations in equipment layout, etc.

**PNP specification** \* The ACR option cannot be selected together due to NPN specification

**Model** **PN**      **Applicable models** **All models**

**Description** The EC series uses NPN specification input/output for connecting external devices as standard. Specifying this option changes input/output to PNP specification.

**Split motor and controller power supply specification** \* The ACR option cannot be selected together due to NPN specification

**Model** **TMD2**      **Applicable models** **All models**

**Description** This option provides a separate motor power supply and control power supply. Select to allow shutting down the actuator drive power only. Please refer to P27 for wiring details.

**Battery-less Absolute Encoder specification**

**Model** **WA**      **Applicable models** **EC-B6S / B7S / B8S**

**Description** EC-B6/B7/B8S use incremental encoders by default. This option installs a battery-less absolute encoder. \* B8SS is automatically equipped with a battery-less absolute encoder.

**Wireless communication specification**

**Model** **WL**      **Applicable models** **All models**

**Description** This option enables support for wireless communication. Specifying this option enables wireless connection with the TB-03 teaching pendant and the wireless teaching controller. The start point, end point, and AVD can be adjusted via wireless communication.

**Wireless axis-operation specification**

**Model** **WL2**      **Applicable models** **All models**

**Description** Specifying WL2 allows for the product to operate wirelessly as with WL (start point, end point, and AVD adjustment), and to also perform operational test moves (forward end/backward end movement, jog, and inching). However, this function is not meant to perform automatic operations. Please contact IAI for precautions on axis operations using a wireless connection. (Note) Customers cannot change WL to WL2, or WL2 to WL.

Duty ratio

The duty ratio is the percentage (%) of the actuator's active operation time in each cycle.

EleCylinder belt driven type can operate at 100% duty rate.

$$D = \frac{T_M}{T_M + T_R} \times 100(\%)$$

D : Duty ratio  
 T<sub>M</sub> : Operating time  
 T<sub>R</sub> : Stopping time

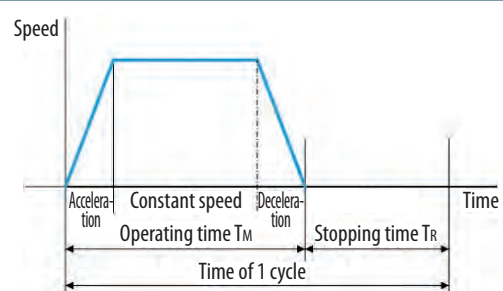

Maintenance parts (Actuator)

EC-B6S(U)  
B7S(U)

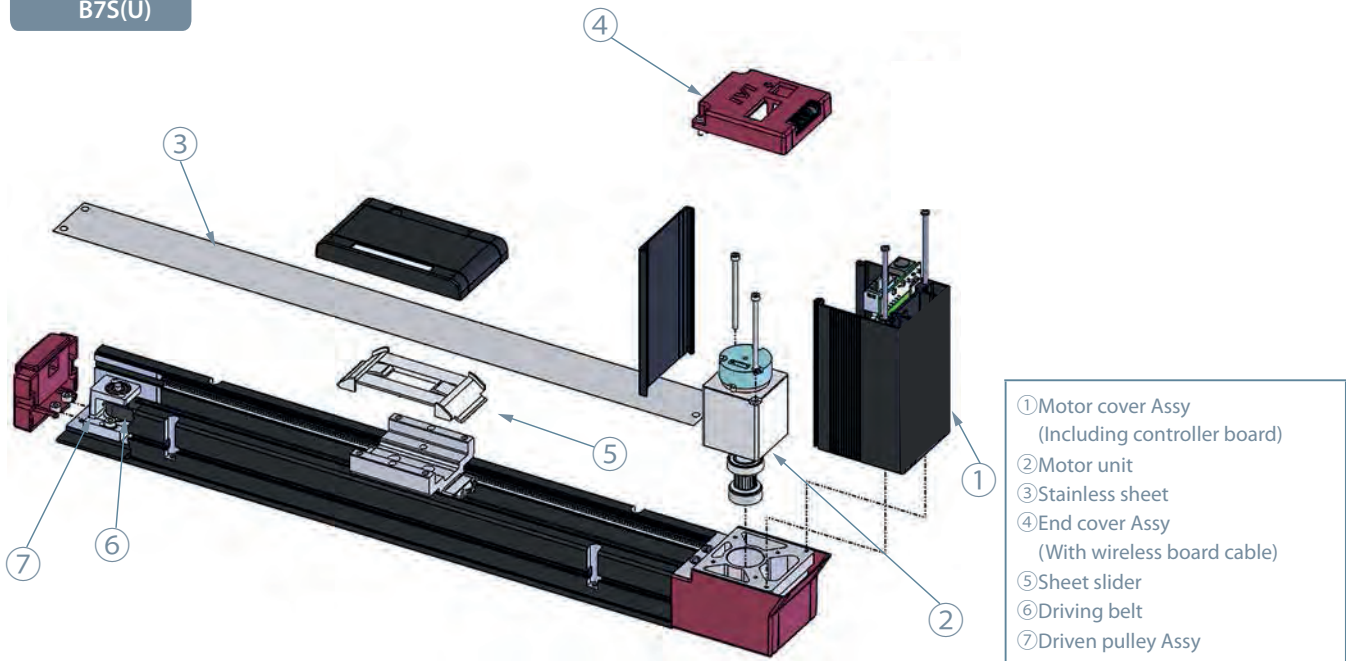

EC-B8S(U)

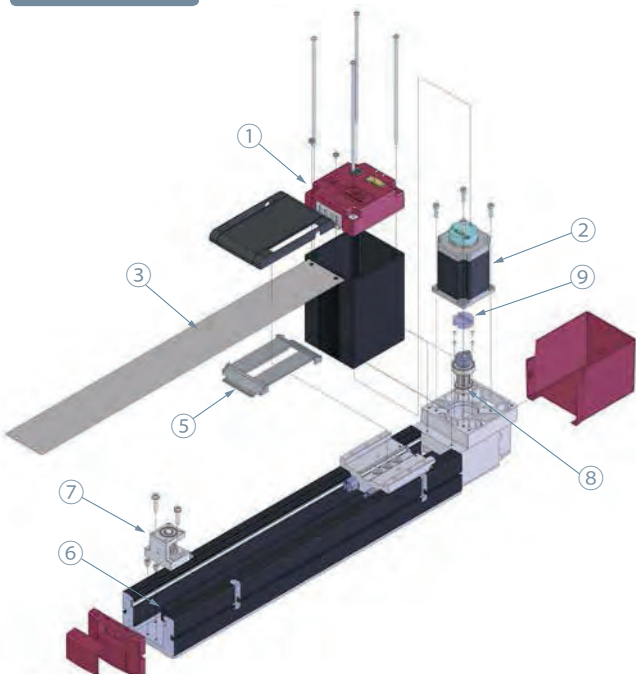

- |  |                       |
|--|-----------------------|
| ① Motor cover Assy<br>(Including controller board) | ⑥ Driving belt        |
| ② Motor unit                                       | ⑦ Driven pulley Assy  |
| ③ Stainless sheet                                  | ⑧ Driving pulley Assy |
| ⑤ Sheet slider                                     | ⑨ Coupling spacer     |

EC-B8SS(U)

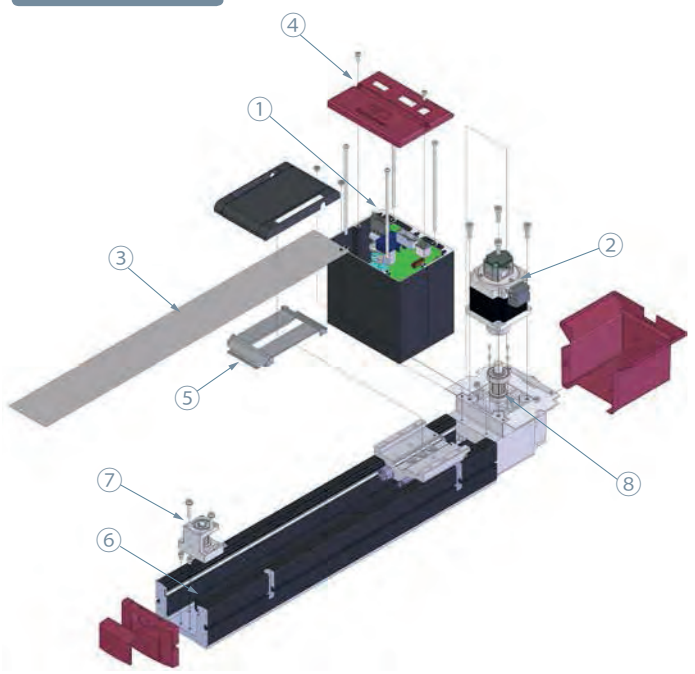

- |  |                       |
|--|-----------------------|
| ① Motor cover Assy<br>(Including controller board) | ⑤ Sheet slider        |
| ② Motor unit                                       | ⑥ Driving belt        |
| ③ Stainless sheet                                  | ⑦ Driven pulley Assy  |
| ④ End cover Assy<br>(With wireless board cable)    | ⑧ Driving pulley Assy |

Numbers in the table correspond to those in the schematic diagram.  
 (Note) The maintenance parts do not come with replacement screws. Contact our sales department for more details.

**①-1 Motor cover Assy**

[Model configuration] Basic model - (ACR selection) - (TMD2 is selection) - (WL2 is selection)

(Ex.) For the specification with TMD2 and WL2:  
 MWB-EC-SR6-TMD2-WL2

Type	Brake	I/O	Basic model	RCON-EC connection specification *	Split motor and controller power *	Wireless axis operation specification
				Model: ACR	Model: TMD2	Model: WL2
B6S	No	NPN	MWB-EC-SR6	ACR (I/O is NPN only)	TMD2	WL2
		PNP	MWB-EC-SR6-P			
	Yes	NPN	MWB-EC-SR6-B			
		PNP	MWB-EC-SR6-B-P			
B7S	No	NPN	MWB-EC-SR7			
		PNP	MWB-EC-SR7-P			
	Yes	NPN	MWB-EC-SR7-B			
		PNP	MWB-EC-SR7-B-P			
B8SS	No	NPN	MWB-EC-B8S			
		PNP	MWB-EC-B8S-P			

\* Some parts for the wireless communication specification (Model: WL).  
 (Note) Wireless communication board is not included.

**①-2 Controller cover Assy**

Type	I/O	Wireless	Model		
			Standard	When TMD2 is selected	When ACR is selected
B8S	NPN	No	CCA-EC-RRB8	CCA-EC-RRB8-TMD2	CCA-EC-RRB8-ACR
		WL	CCA-EC-RRB8-WL	CCA-EC-RRB8-TMD2-WL	CCA-EC-RRB8-ACR-WL
		WL2	CCA-EC-RRB8-WL2	CCA-EC-RRB8-TMD2-WL2	CCA-EC-RRB8-ACR-WL2
	PNP	No	CCA-EC-RRB8-P	CCA-EC-RRB8-P-TMD2	
		WL	CCA-EC-RRB8-P-WL	CCA-EC-RRB8-P-TMD2-WL	
		WL2	CCA-EC-RRB8-P-WL2	CCA-EC-RRB8-P-TMD2-WL2	

**② Motor unit**

Type	Encoder	Brake	Model
B6S	Incremental	No	EC-MUB6
		Yes	EC-MUB6-B
	Battery-less absolute	No	EC-MUB6-WA
		Yes	EC-MUB6-WA-B
B7S	Incremental	No	EC-MUB7
		Yes	EC-MUB7-B
	Battery-less absolute	No	EC-MUB7-WA
		Yes	EC-MUB7-WA-B
B8S	Incremental	No	EC-MUSB8
	Battery-less absolute		EC-MUSB8-WA
B8SS	Battery-less absolute	No	EC-MUS13

**③ Stainless sheet**

Type	Model
B6S	ST-EC-B6-○○○
B7S	ST-EC-B7-○○○
B8S/B8SS	ST-EC-B8-○○○

\* ○○○ indicates stroke

**④ End cover Assy**

Type	Model
B6S	EWB-EC-SR6
B7S	EWB-EC-SR7
B8SS	EWB-EC-B8S

(Note) Includes a wireless communication board.  
 Contact one of our representatives for a non-wireless specification.

**⑤ Sheet slider**

Type	Model
B6	SHS-EC-B6
B7	SHS-EC-B7
B8S/B8SS	SHS-EC-B8

**⑥ Driving belt**

Type	Model
B6	LB-EC-B6-○○○
B7	LB-EC-B7-○○○
B8S/B8SS	LB-EC-B8-○○○

\* ○○○ indicates stroke

**⑦ Driven pulley Assy**

Type	Model
B6	PLY-EC-B6
B7	PLY-EC-B7
B8S/B8SS	PLY-EC-B8

**⑧ Driving pulley Assy**

Type	Model
B8S	DPLY-EC-B8
B8SS	DPLY-EC-B8S

**⑨ Coupling spacer**

Type	Model
B8S	CPG-EC-SR7

System configuration [24VDC pulse motor models]

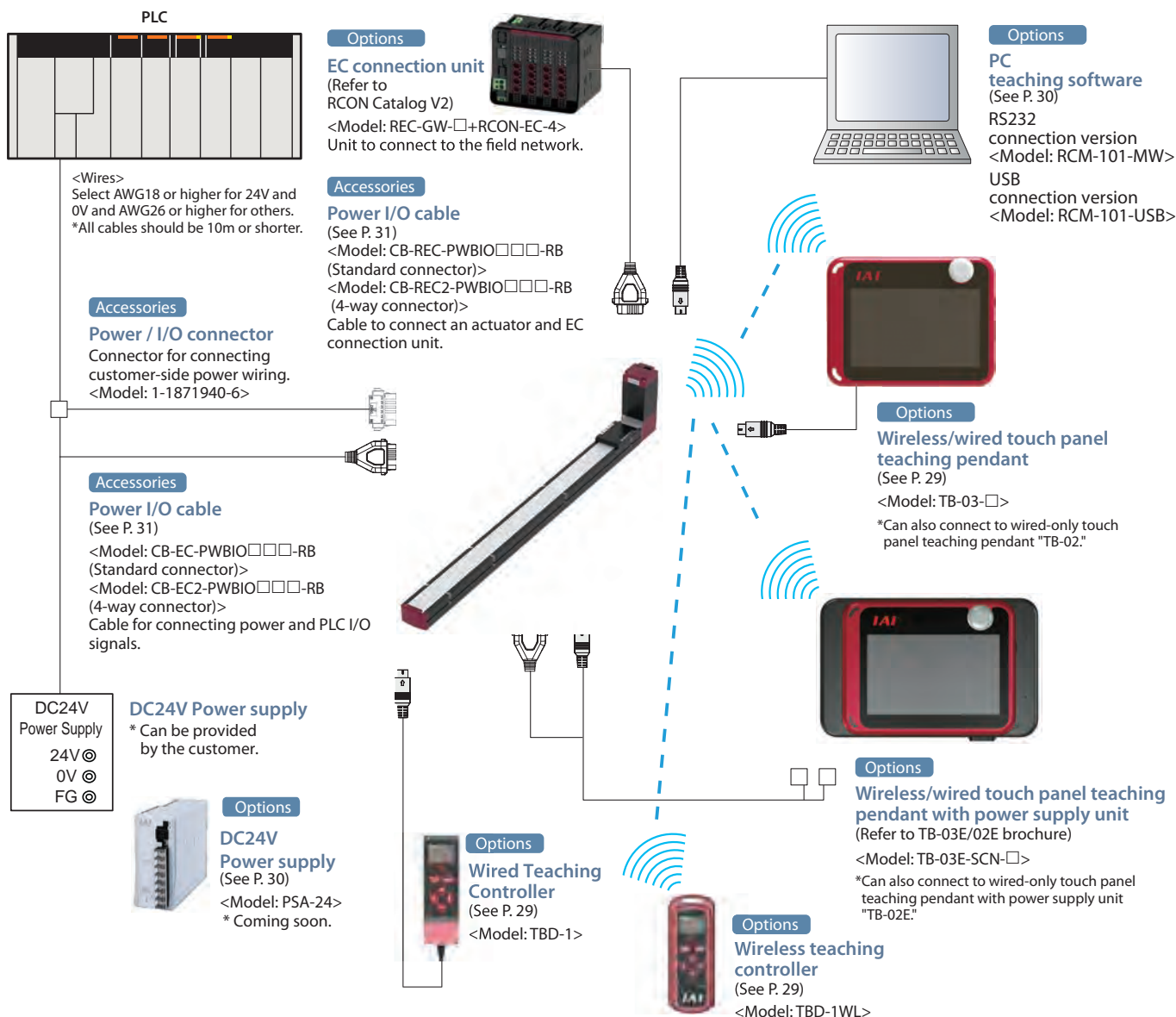

List of accessories [24VDC pulse motor models]

■ Power I/O Cables, Connectors

[Standard connector]

Product category		Accessories
Power I/O cable length (selected with actuator model)	RCON-EC connection specification (ACR) selection	
0	No	Power / I/O connector (1-1871940-6)
	Yes	—
1 ~ 10	No	Power I/O cable (CB-EC-PWBIO□□□-RB)
	Yes	Power I/O cable (CB-REC-PWBIO□□□-RB)

[Four-way connector]

Product category		Accessories
Power I/O cable length (selected with actuator model)	RCON-EC connection specification (ACR) selection	
S1 ~ S10	No	Power I/O cable (CB-EC2-PWBIO□□□-RB)
	Yes	Power I/O cable (CB-REC2-PWBIO□□□-RB)

**Basic controller specifications [24VDC pulse motor models]**

Specification item		Specification content	
Number of controlled axes		1 axis	
Power supply voltage		24VDC $\pm$ 10%	
Power capacity (Including 0.3A Control power) (Note 1)	B6S/B7S	With energy-saving setting disabled: Rated 3.5A, Max. 4.2A With energy-saving setting enabled: Max. 2.2A	
	B8S	Max. 6A (Only for energy-saving disabled)	
Brake release power supply		24VDC $\pm$ 10%, 200mA (only for external brake release)	
Generated heat (at duty ratio 100%)	B6S/B7S	8W	
	B8S	19.2W	
Inrush current (Note 2)	(D)B6S/(D)B7S	8.3A (with inrush current limiting circuit)	
	B8S	10A	
Momentary power failure resistance		Max. 500 $\mu$ s	
Motor size		<input type="checkbox"/> 42, <input type="checkbox"/> 56, <input type="checkbox"/> 56SP	
Motor rated current	B6S/B7S	1.2A	
	B8S	4A	
Motor control system		Weak field-magnet vector control	
Supported encoders		Incremental (800 pulse/rev), battery-less absolute encoder (800 pulse/rev)	
SIO		RS485 1ch (Modbus protocol compliant)	
PIO	Input specification	No. of input	3 points (forward, backward, alarm clear)
		Input voltage	24VDC $\pm$ 10%
		Input current	5mA per circuit
		Leakage current	Max. 1mA/1 point
	Output specification	Isolation method	Non-isolated
		No. of output	3 points (forward complete, backward complete, alarm)
		Output voltage	24VDC $\pm$ 10%
		Output current	50mA/1 point
	Residual voltage	2V or less	
	Isolation method	Non-isolated	
Data setting and input methods		PC-compatible teaching software, touch panel teaching pendant, digital speed controller, wireless teaching controller, wired teaching controller	
Data retention memory		Position and parameters are saved in non-volatile memory. (No limit to rewrite)	
LED display	Controller status display	Servo ON (green light ON) / Alarm (red light ON) / Initializing when power comes ON (orange light ON) / Minor failure alarm (green/red alternately blinking) / Operation from teaching: Stop from teaching (red light ON) / Servo OFF (light OFF) / Automatic servo OFF (green light flashing)	
	Wireless status display	Initializing wireless hardware, without wireless connection, or connecting from TP board (light OFF) Connecting through wireless (green blinking) / Wireless hardware error (red blinking) / Initializing when power comes ON (orange light ON)	
Predictive maintenance/Preventative maintenance		When the number of movements or operation distance has exceeded the set value and when the LED (right side) blinks alternately green and red at overload warning * Only when configured in advance	
Ambient operating temperature		0 to 40°C	
Ambient operating humidity		5% RH ~ 85% RH or less (no condensation or freezing)	
Operating ambience		Avoid corrosive gas and excessive dust	
Insulation resistance		500VDC 10M $\Omega$	
Electric shock protection mechanism		Class 1 basic insulation	
Cooling method		Natural air cooling	

(Note 1) When connecting RCON-EC, the value is subtracted by 0.3A from the control power supply.

(Note 2) Inrush current flows for approximately 5ms after the power is input (At 40°C). Inrush current value differs depending on the impedance on the power supply line.

**Solenoid valve method**

EleCylinder employs the double solenoid valve system normally.

When using a single solenoid system, change Parameter No. 9 "Solenoid valve system selection."

(Note) When connecting to RCON-EC, the single solenoid valve does not operate.

System configuration [230VAC servo motor models]

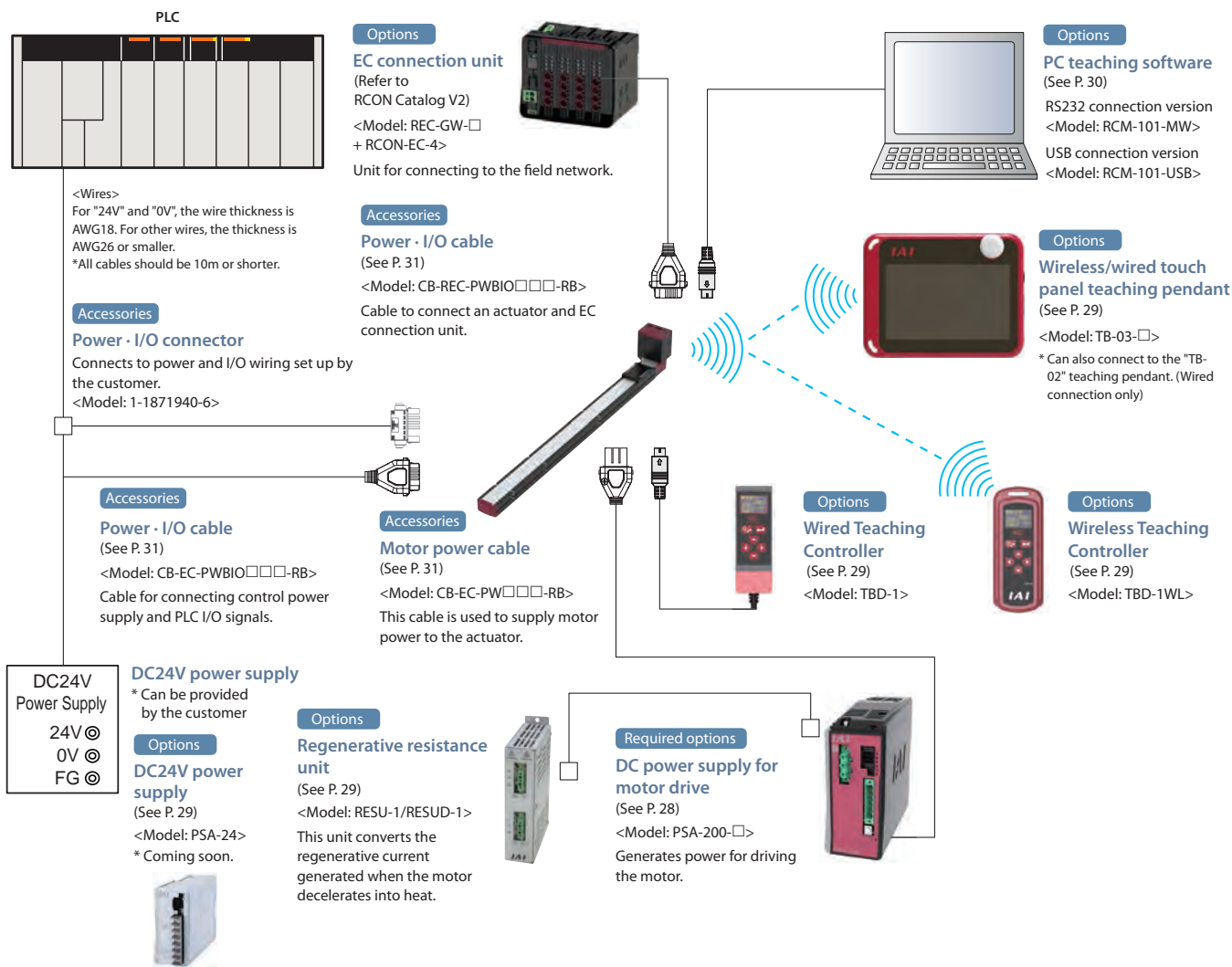

List of accessories [230VAC servo motor models]

■ Power · I/O cable

Product category		Accessories
Power · I/O cable length (selected with actuator model)	RCON-EC connection specifications (ACR) selection	
0	No	Power · I/O connector (1-1871940-6)
	Yes	—
1 to 10	No	Power · I/O cable (CB-EC-PWBIO□□□-RB)
	Yes	Power · I/O cable (CB-REC-PWBIO□□□-RB)

■ Motor power cable

Product category		Accessories
Motor power cable length (selected with actuator model)	RCON-EC connection specifications (ACR) selection	
0	No	—
	Yes	—
1 to 10	No	—
	Yes	Motor power cable (CB-EC-PW□□□-RB)

**Basic controller specifications [230VAC servo motor models]**

Specification item		Description	
Number of controlled axes		1 axis	
Motor power input voltage		Supplied by PSA-200 (280VDC type)	
Control power input voltage		24VDC $\pm$ 10%	
Control power current	Control	320mA	
	Teaching (Note 1)	150mA	
Control power capacity	Control	7.6W	
	Teaching (Note 1)	3.6W	
Inrush current		-	
Momentary power failure resistance		max 500 $\mu$ s	
Applicable motor wattage		200W	
Motor control method		Sine wave PWM vector current control	
Compatible encoder		Battery-less absolute encoder (16384pulse/rev)	
SIO		RS-485 1 ch (conforms to Modbus protocol)	
PIO	Input specification	Number of inputs	3 points (forward, backward, alarm reset)
		Input voltage	24VDC $\pm$ 10%
		Input current	5mA/ circuit
		Leak current	Max. 1mA/ point
		Insulation method	Non-insulation
	Output specification	Number of outputs	3 points (forward, backward, alarm reset)
		Output voltage	24VDC $\pm$ 10%
		Output current	50mA/ point
		Residual voltage	2V or less
		Insulation method	Non-insulation
Data setting, input method		PC-compatible teaching software, touch panel teaching pendant, wireless teaching controller, wired teaching controller	
Data retention memory		Retains position data and parameters to non-volatile memory (no limit for the number of writings)	
LED display	Controller status display (right)	Servo ON (green light on) / Alarm (red light on) / Initialization at power ON (orange light on) / Alarm for minor failure (green light flashing) / Operations from teaching: Stops from at teaching (red light on) / Servo OFF (light turns OFF) / Automatic servo OFF (green light flashing)	
	Motor power status display (center)	Motor power ON (green light on) / Motor power OFF (green light flashing)	
	Wireless status display (left)	Initializing wireless hardware or wireless not connected, or connected from the teaching pendant (light turned off) Wireless connected (green flashing) / Wireless hardware abnormal (red light flashing) / Initializing after power on (orange light on)	
	Charging status display (I/O connector side)	Internal circuit charging status (red light on) / Internal circuit not charged (light off) (Note 2)	
Predictive and preventive maintenance		When the number of travels and travel distance exceed the preset values or when an overload warning is activated, LED (right side) lamp will flash. * Only when the value exceeds the preset one.	
Operating ambient temperature		0-40°C	
Operating ambient humidity		5-85%RH or less (non-condensing, no frost)	
Operating ambient atmosphere		No corrosive gases, not excessive dust	
Insulation resistance		500VDC 10M $\Omega$	
Electric shock protection mechanism		Class 1 basic insulation	
Cooling system		Natural air cooling	

(Note 1) Add when connecting the teaching pendant.

(Note 2) While the charge status LED is lit on, inside the controller has been recharged. To prevent electric shock, wiring and inspection works must be performed after the LED is turned off.

**Solenoid valve method**

EleCylinder employs the double solenoid valve system normally.

When using a single solenoid system, change Parameter No. 9 "Solenoid valve system selection."

(Note) When connecting to RCON-EC, the single solenoid valve does not operate.

Table of connectability between EleCylinder and teaching pendants

■ EleCylinder single unit

○: Connection/Operation possible

Teaching tool		Connection/operation	Preference order (for simultaneous connection)
Wired connection	TB-02/03	○	1
	Wired Teaching Controller	○	1
Wireless connection	TB-03	○ *1 *2	2
	Wireless Teaching Controller	○ *1 *2	2

\*1 Connectable only when EleCylinder is the wireless connection specification (with optional WL or WL2).

\*2 Trial operations are impossible when connecting to the WL specification. Trial operations are possible when connecting to the WL2 specification.

■ When connecting EleCylinder with REC/RCON/RSEL (RCON-EC-4 connection)



○: Connection/Operation possible △: Connectable/Some operations impossible —: Not connectable

Teaching tool		Connection patterns	AUTO (during automatic operation)		Manual	
			Connection/operation	Preference order (for simultaneous connection)	Connection/operation	Preference order (for simultaneous connection)
Wired connection	TB-02/03	(A)	—	—	—	—
		(B)	△ *4	1	○	1
	Wired Teaching Controller	(A)	—	—	—	—
		(B)	—	—	—	—
Wireless connection	TB-03	(C)	△ *1 *4	2	○ *1 *2	2
	Wireless Teaching Controller	(C)	△ *1 *3	2	○ *1 *2	2

\*1 Connectable only when EleCylinder is the wireless connection specification (with optional WL or WL2).

\*2 Trial operations are impossible when connecting to the WL specification. Trial operations are possible when connecting to the WL2 specification.

\*3 Setting and operations of speed, acceleration/deceleration are possible. Position edit and trial operations are impossible.

\*4 Only monitor is supported (operations are impossible)

I/O (Input/Output) Specifications

I/O		Input		Output	
Specifications		Input voltage	24VDC ± 10%	Load voltage	24VDC ± 10%
		Input current	5mA per circuit	Maximum load current	50mA/1 point
		ON/OFF voltage	ON voltage: min. 18VDC OFF voltage: max. 6VDC	Residual voltage	2V or less
		Leakage current	Max. 1mA/1 point	Leakage current	Max. 0.1mA/1 point
Isolation method		Non-isolated from external circuit		Non-isolated from external circuit	
I/O logic	NPN				
	PNP				

(Note) Isolation method is non-isolated. When connecting an external device (such as a PLC) to EleCylinder, use the same ground as EleCylinder.

I/O Signal Wiring Diagram

I/O		Standard specification	Split motor/controller power specification (option model: TMD2)
Power • I/O connector		<p>0V A1 (Reserved) A2 Backward complete A3 Forward complete A4 Alarm output A5 (Reserved) A6</p> <p>B1 24V B2 Brake release (Note 1) B3 Backward command (Note 2) B4 Forward command (Note 2) B5 Alarm cancel B6 (Reserved)</p>	<p>Drive power and control power are separate for the TMD2 specification.</p> <p>0V A1 24V (Control) A2 Backward complete A3 Forward complete A4 Alarm output A5 (Reserved) A6</p> <p>B1 24V (Drive/E-stop) (Note 3) B2 Brake release (Note 1) B3 Backward command (Note 2) B4 Forward command (Note 2) B5 Alarm cancel B6 (Reserved)</p>
I/O logic	NPN	<p>0V 24V</p> <p>A1 B1 24V B2 Brake release (Note 1)</p> <p>(Note 2) Backward command B3 A3 Backward complete (Note 2) Forward command B4 A4 Forward complete Alarm cancel B5 A5 Alarm output</p>	<p>0V 24V</p> <p>A1 B1 24V (Drive/E-stop) (Note 3) B2 Brake release (Note 1) A2 24V (Control)</p> <p>(Note 2) Backward command B3 A3 Backward complete (Note 2) Forward command B4 A4 Forward complete Alarm cancel B5 A5 Alarm output</p>
	PNP	<p>24V 0V</p> <p>24V B1 A1 0V (Note 1) Brake release B2</p> <p>(Note 2) Backward command B3 A3 Backward complete (Note 2) Forward command B4 A4 Forward complete Alarm cancel B5 A5 Alarm output</p>	<p>24V 0V</p> <p>(Note 3) 24V (Drive/E-stop) B1 A1 0V (Note 1) Brake release B2</p> <p>24V (Control) A2</p> <p>(Note 2) Backward command B3 A3 Backward complete (Note 2) Forward command B4 A4 Forward complete Alarm cancel B5 A5 Alarm output</p>

(Note 1) The B8S and B8SS do not use this signal.

(Note 2) Switching to the single solenoid method will change B3 to "Forward/Backward command" and B4 to "Unused."

(Note 3) The signal name for B6/B7/B8S is "Drive". The signal name for B8SS is "E-stop."

To shut off the servo power on a B8SS, it is also necessary to shut off the AC power (L1 and L2) of the PSA-200.

## I/O Signal Table

Power · I/O connector pin assignment			
Pin Number	Connector nameplate label	Signal abbreviation	Function overview
B3 (Note 1)	Backward	ST0	Backward command
B4 (Note 1)	Forward	ST1	Forward command
B5	Alarm clear	RES	Alarm clear
A3	Backward complete	LS0	Backward complete
A4	Forward complete	LS1	Forward complete
A5	Alarm	*ALM	Alarm detection (b-contact)
B2	Brake release	BKRLS	Brake forced release (for brake equipped specification)
B1 (Note 2)	24V	24V	24V input
A1	0V	0V	0V input
A2 (Note 2)	(24V)	(24V)	24V input

(Note 1) Switching to single solenoid operation will change B3 to "Forward/Backward" and B4 to "Unused". However, the power · I/O connector nameplate will still read "B3: Backward" and "B4: Forward".

(Note 2) In the case of double power circuit specification (TMD2), B1 is 24V (Drive/E-stop) and A2 is 24V (control).

## Required accessories [230VAC servo motor models]

### DC power supply for motor drive

- Features:** This unit supplies DC power source for driving actuator motors. One unit can supply power for up to 6 axes. (within the maximum connectable wattage)  
 Regenerative resistance units may be needed depending on the number of connected axes and the mounting orientation. Refer to the next page for details.

- Model** **PSA-200-2**  
 (Input voltage: 230VAC single-phase maximum wattage: 1600W)

#### Configuration connected by motor power cable



<Recommended models>  
 NF2010A-UP (Manufacturer: Soshin Electric)  
 NAC-10-472 (Manufacturer: COSEL)

Actuator motor wattage (W)
EC-B8SS 200W

#### Specifications

Power input voltage range	230AC single-phase specification: 200~230VAC ±10%	
Input frequency range	50Hz ±5%	
Inrush current (Note 1)	55°C	Control power supply: 60A Motor power supply: 70A
Output voltage	280VDC	
Maximum wattage with motors connected	230VAC single-phase specification: 1600W	
Max. number of connectable axes	6 axis	
Momentary power failure capability	50Hz: 20ms	
Dielectric withstanding voltage	Between primary and FG 1500VAC 1 min	
Insulation resistance	Between secondary and FG 500VDC 10MΩ or more	
Leakage current	3.1mA total (with recommended noise filter, 6-axis connected)	
Electric shock protection mechanism	Class 1 basic insulation	

(Note 1) Inrush current flows for approximately 20ms after power ON. Note that the inrush current value varies depending on the impedance of the power supply line and the internal element temperature (thermistor).

#### Names of each part

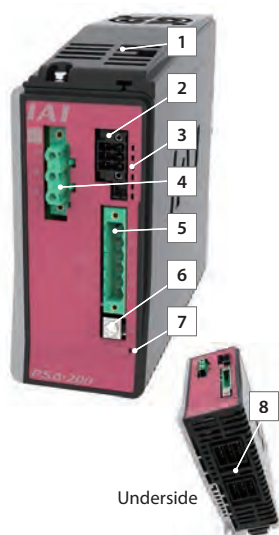

- Fan unit
- Status output connector
- Status indicator LED
- Regenerative unit cable connector
- Power connector
- Grounding terminal
- Charging status indicator LED \*1
- Motor power connector

\*1 When the charge status indicator LED is lit, the battery is charged inside the PSA-200. To prevent electric shock, wiring and inspection work should be performed after the power is shut off and after confirming that the LEDs are turned off.

#### External dimensions

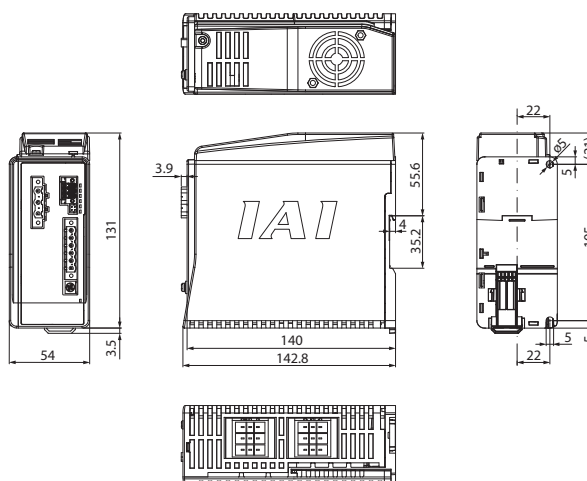

### Regenerative resistance unit

- Features** This unit converts the regenerative current generated when the motor decelerates into heat. Calculate the total wattage of the connected actuators and refer to the "Rough guide of required regenerative resistance units" on the right. Purchase regenerative resistor units if necessary.
- Model** **RESU-1** (standard specification) / **RESUD-1** (DIN rail installation specification)

**Specifications**

Model	RESU-1	RESUD-1
Main unit weight	Approx. 0.4kg	
Built-in regenerative resistance value	235Ω 80W	
Main unit installation method	Screw fixed	DIN rail fixed
Attached cable	CB-ST-REU010	

**External dimensions**

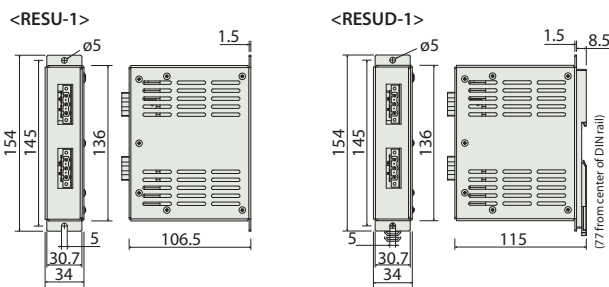

### Wireless/wired touch panel teaching pendant

- Features** This teaching device supports wireless connections. Start point/end point/AVD input and axis operation can be performed wirelessly (WL or WL2 option required).
- Model** **TB-03-** Please check our website for supported versions.
- Configuration** Wireless or wired connection

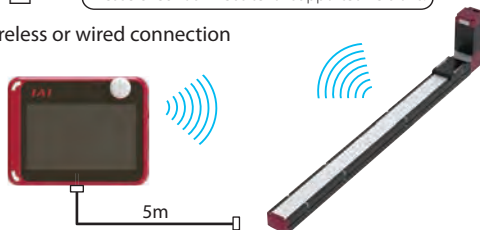

### Wireless teaching controller

- Features** Easily perform starting point / end point / AVD input and jogging operations from a remote location (WL or WL2 option required).
- Model** **TBD-1WL-**
- Configuration** Wireless connection



### Wired teaching controller

- Features** Easily perform start point / end point / AVD input and jogging operations. The wired connection allows for use with all EleCylinder models.
- Model** **TBD-1**
- Configuration** Wired connection

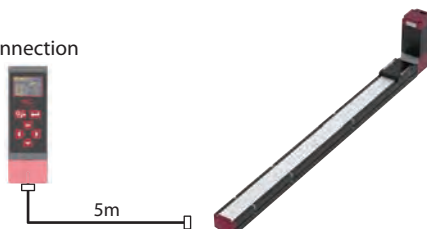

### Rough guide of required regenerative resistance units

Actuator-mounted motor wattage (W)

EC-B85S	200W
---------	------



Wattage (total)	Horizontal								
	0	200	400	600	800	1000	1200	1400	1600
0	0	0	0	0	0	0	1	1	1
200	0	1	1	1	1	1	1	1	-
400	1	1	1	1	2	2	2	-	-
600	1	1	2	2	2	2	-	-	-
800	1	2	2	2	2	-	-	-	-
1000	2	2	2	2	-	-	-	-	-
1200	2	2	3	-	-	-	-	-	-
1400	2	3	-	-	-	-	-	-	-
1600	3	-	-	-	-	-	-	-	-

**<Caution>**

- The above table is criteria for a round-trip operation at the rated acceleration/deceleration speed, rated load, and 1000mm stroke at the actuator's operating duty ratio of 50%.
- Regenerative energy is also absorbed in the controller, but if it exceeds the allowed amount, an excessive estimated regenerative discharge power alarm occurs, so connect an additional external regenerative resistance unit. If the operating duty is higher than 50% or the vertical payload is heavy, you may need more regenerative resistance units than specified in the table above. The maximum number of regenerative resistance units that can be connected is 5. Never connect more than 5 units as it may cause malfunction.
- To find the optimum number of regen units for your operating conditions, please use a calculator software.

**Specifications**

Rated voltage	24V DC
Power consumption	3.6W or less (150mA or less)
Ambient operating temperature	0~40°C
Ambient operating humidity	20~85% RH (must be no condensation)
Ingress protection	IPX0
Mass	Approx. 485g (main unit) + approx. 175g (battery)
Charging method	Wired connection with dedicated adapter / controller
Wireless connection	Bluetooth 4.2 class 2

**Specifications**

Power input voltage range	5.9V DC (5.7~6.3V) [supplied by dedicated AC adapter]
Ambient operating temperature	0~40°C (no condensation or freezing)
Ambient operating humidity	5~85% RH or less (no condensation or freezing)
Ingress protection	IPX0
Mass	Approx. 115g (including 55g battery mass)
Charging method	Dedicated adapter
Wireless connection	Bluetooth 4.2 class 2

**Specifications**

Rated voltage	24V DC ±10% [supplied from controller]
Power consumption	1.44W or less (60mA or less)
Ambient operating temperature	0~40°C (no condensation or freezing)
Ambient operating humidity	5~85% RH or less (no condensation or freezing)
Ingress protection	IP20
Mass	21g (main unit) + 184g (main unit integrated cable 5m)

## PC teaching software (Windows only)

- **Features** This software provides functions such as position teaching, trial operation, and monitoring. It provides a complete range of functions required to make adjustments, to help reduce start-up time.

- **Model** **RCM-101-MW** (with an external device communication cable + RS232 conversion unit)

### Configuration

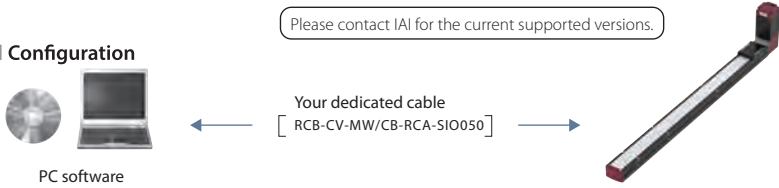

- **Model** **RCM-101-USB** (with an external device communication cable + USB conversion adapter + USB cable)

### Configuration

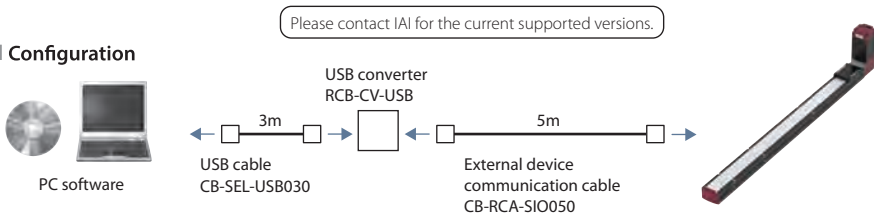

## 24V power supply

- **Model** **PSA-24** (without fan) *Coming soon*

- **Model** **PSA-24L** (with fan) *Coming soon*



### Specifications Table

Item	Specifications
	230VAC input
Power input voltage range	230VAC ±10%
Input power supply current	1.9A or less
Power capacity	Without fan: 280VA With fan: 380VA
Inrush current*1	Without fan: 34A (typ.) With fan: 54.8A (typ.)
Generated heat	23W (204W continuous rated) 37W (330W continuous rated)
Output voltage range*2	24V ±10%
Continuous rated output	Without fan: 8.5A (204W) With fan: 13.8A (330W)
Peak output	17A (408W)
Efficiency	90% or more
Parallel connection*3	Up to 5 units

\*1 The pulse width of flowing inrush current is less than 5ms.

\*2 In order to enable parallel operation, this power supply can vary the output voltage according to the load. The power supply unit is therefore for use with IAI controllers only.

\*3 Parallel connection cannot be used under the following conditions.

- Parallel connection of PSA-24 (specification without fan) and PSA-24L (specification with fan)
- Parallel connection with a power supply unit other than this power supply

### External Dimensions

#### PSA-24

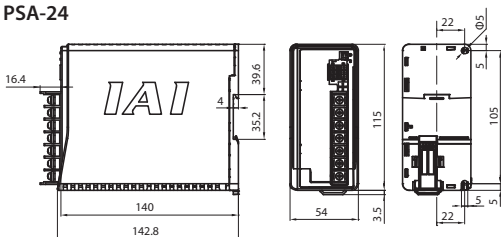

#### PSA-24L

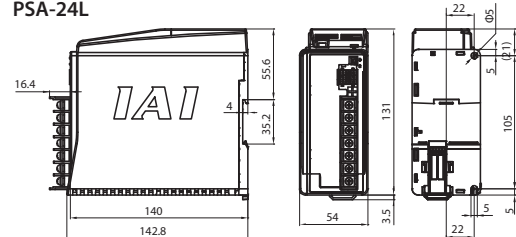

Maintenance parts (cables)

When ordering cables for replacement, etc. after purchase, indicate the model codes below.

■ Cable types

Cable type	Cable model number	Applicable models
Power · I/O cable (flying leads)	CB-EC-PWBIO□□□-RB	All models
Power · I/O cable (flying leads, 4-way connector)	CB-EC2-PWBIO□□□-RB	Pulse motor only
Power · I/O cable (RCON-EC connection specification)	CB-REC-PWBIO□□□-RB	All models
Power · I/O cable (RCON-EC connection specification, 4-way connector)	CB-REC2-PWBIO□□□-RB	Pulse motor only
Motor power cable	CB-EC-PW□□□-RB	230VAC Servo motor only

Model **CB-EC-PWBIO□□□-RB** \* Indicate the cable length (L) in □□□. Up to 8m, (e.g.) 030=3m

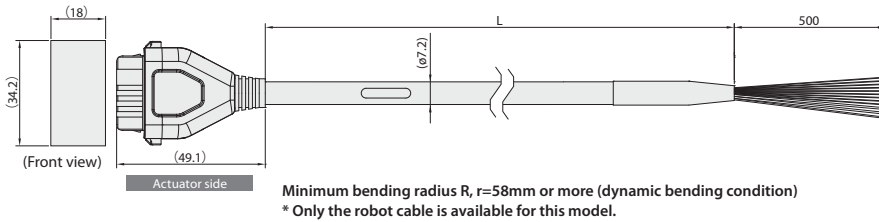

1-1871940-6

Color	Signal name	Pin No.
Black(AWG18)	0V	A1
Red(AWG18)	24V	B1
Light blue(AWG22)	(Reserved) (Note 1)	A2
Orange(AWG26)	IN0	B3
Yellow(AWG26)	IN1	B4
Green(AWG26)	IN2	B5
Pink(AWG26)	(Reserved)	B6
Blue(AWG26)	OUT0	A3
Purple(AWG26)	OUT1	A4
Gray(AWG26)	OUT2	A5
White(AWG26)	(Reserved)	A6
Brown(AWG26)	BKRLS	B2

(Note 1) 24V (control) when Split motor and controller power (TMD2) is selected.

(Note) Yellow-green and light gray wires are not used (already cut inside the shrink tube).

Model **CB-EC2-PWBIO□□□-RB** \* Indicate the cable length (L) in □□□. Up to 8m, (e.g.) 030=3m

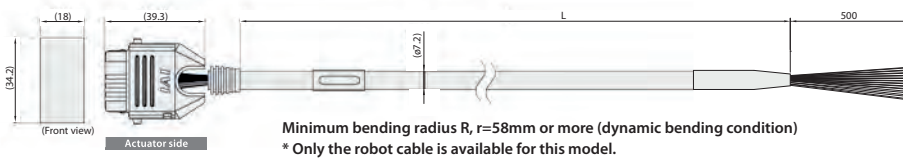

1-1871940-6

Color	Signal name	Pin No.
Black(AWG18)	0V	A1
Red(AWG18)	24V	B1
Light blue(AWG22)	(Reserved) (Note 1)	A2
Orange(AWG26)	IN0	B3
Yellow(AWG26)	IN1	B4
Green(AWG26)	IN2	B5
Pink(AWG26)	(Reserved)	B6
Blue(AWG26)	OUT0	A3
Purple(AWG26)	OUT1	A4
Gray(AWG26)	OUT2	A5
White(AWG26)	(Reserved)	A6
Brown(AWG26)	BKRLS	B2

(Note 1) 24V (control) when Split motor and controller power (TMD2) is selected.

(Note) Yellow-green and light gray wires are not used (already cut inside the shrink tube).

Model **CB-REC-PWBIO□□□-RB** \* Indicate the cable length (L) in □□□. Up to 8m, (e.g.) 030=3m

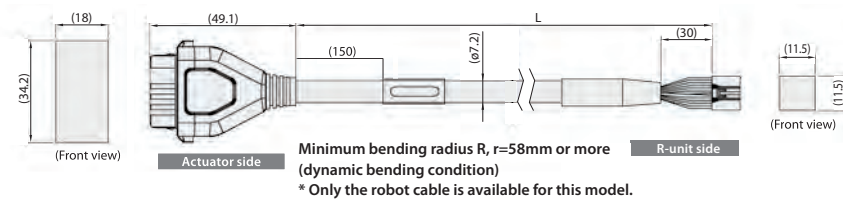

1-1871940-6

Color	Signal name	Pin No.
Black(AWG18)	0V	A1
Red(AWG18)	24V(MP)	B1
Light blue(AWG22)	24V(CP)	A2
Orange(AWG26)	IN0	B3
Yellow(AWG26)	IN1	B4
Green(AWG26)	IN2	B5
YellowGreen(AWG26)	SD+	B6
Light gray(AWG26)	SD-	A6
Blue(AWG26)	OUT0	A3
Purple(AWG26)	OUT1	A4
Gray(AWG26)	OUT2	A5
Brown(AWG26)	BKRLS	B2

DF62E-13S-22C(18)

Pin No.	Signal name	Color
2	0V	Black(AWG18)
1	24V(MP)	Red(AWG18)
12	24V(CP)	Light blue(AWG22)
7	OUT0	Orange(AWG26)
8	OUT1	Yellow(AWG26)
9	OUT2	Green(AWG26)
6	SD+	YellowGreen(AWG26)
10	SD-	Light gray(AWG26)
3	IN0	Blue(AWG26)
4	IN1	Purple(AWG26)
5	IN2	Gray(AWG26)
11	BKRLS	Brown(AWG26)
13	FG	Green(AWG26)

Model **CB-REC2-PWBIO□□□-RB** \* Indicate the cable length (L) in □□□. Up to 8m, (e.g.) 030=3m

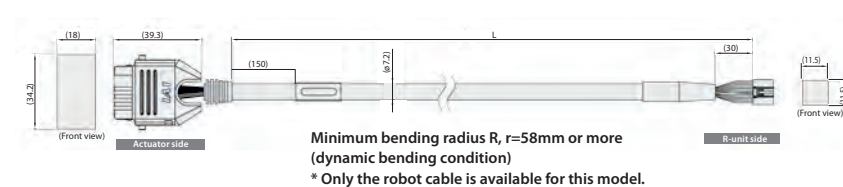

1-1871940-6

Color	Signal name	Pin No.
Black(AWG18)	0V	A1
Red(AWG18)	24V(MP)	B1
Light blue(AWG22)	24V(CP)	A2
Orange(AWG26)	IN0	B3
Yellow(AWG26)	IN1	B4
Green(AWG26)	IN2	B5
YellowGreen(AWG26)	SD+	B6
Light gray(AWG26)	SD-	A6
Blue(AWG26)	OUT0	A3
Purple(AWG26)	OUT1	A4
Gray(AWG26)	OUT2	A5
Brown(AWG26)	BKRLS	B2

DF62E-13S-22C(18)

Pin No.	Signal name	Color
2	0V	Black(AWG22)
1	24V(MP)	Red(AWG22)
12	24V(CP)	Light blue(AWG22)
7	OUT0	Orange(AWG26)
8	OUT1	Yellow(AWG26)
9	OUT2	Green(AWG26)
6	SD+	YellowGreen(AWG26)
10	SD-	Light gray(AWG26)
3	IN0	Blue(AWG26)
4	IN1	Purple(AWG26)
5	IN2	Gray(AWG26)
11	BKRLS	Brown(AWG26)
13	FG	Green(AWG26)

Model **CB-EC-PW□□□-RB** \* Indicate the cable length (L) in □□□. Up to 8m, (e.g.) 030=3m

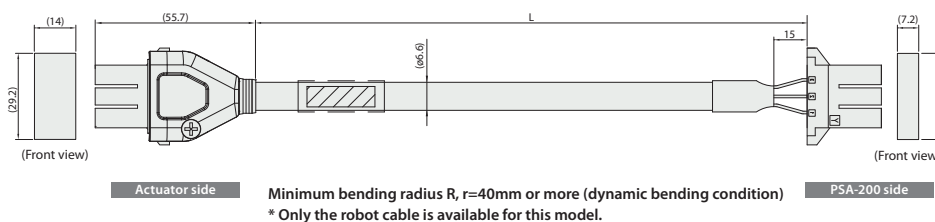

Color	Signal name	Pin No.	Pin No.	Signal name	Color
Red(AWG18)	MP	1	1	MP	Red(AWG18)
Black(AWG18)	MN	2	2	MN	Black(AWG18)
Green/ Yellow(AWG18)	PE	3	3	PE	Green/ Yellow(AWG18)

## ■ Four-way connector cable

\* Models equipped with a pulse motor

This cable can change the EleCylinder cable connector to four directions.

The cable wiring for the connector is the same as that of power / I/O cable CB-EC-PWBIO□□□-RB / CB-REC-PWBIO□□□-RB.

### ■ Model

Indicate the cable length (L) in □□□, (e.g.) 050=5m

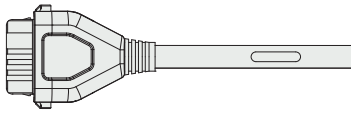
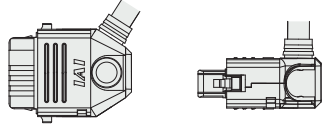
	Standard connector (actuator side)	4-way connector (actuator side)
External view		
Flying leads	CB-EC-PWBIO□□□-RB	CB-EC2-PWBIO□□□-RB
RCON-EC connection specification	CB-REC-PWBIO□□□-RB	CB-REC2-PWBIO□□□-RB

### ■ Ordering method

The cable length is minimum 1m and maximum 10m.  
Can be specified in 1m units.

(ex.) When ordering a 4-way connector with a 3m/10m cable.  
Cable length **3m** : CB-EC2-PWBIO**030**-RB  
Cable length **10m** : CB-EC2-PWBIO**100**-RB

### ■ Assembling method

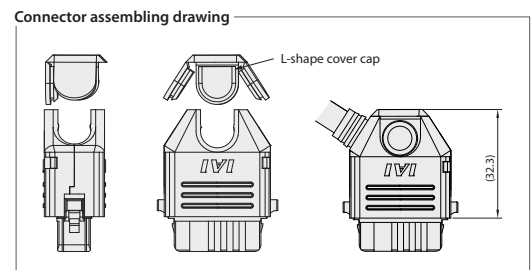
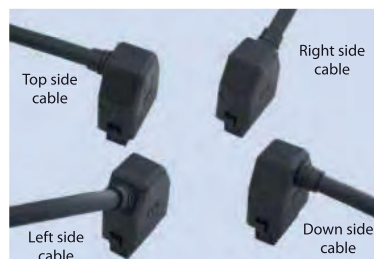

① Insert while sliding along the groove in the desired direction from the semi-cylindrical curved portion.

② Confirm that the cable has been firmly inserted, and then insert the 2 sides of the lid along the groove.

③ Finally, press the remaining side of the lid.

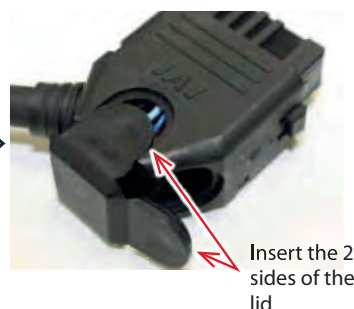
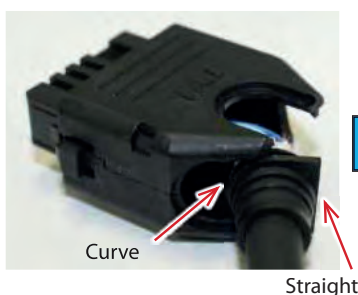

**EC EleCylinder Series  
Belt Type V3  
Catalogue No. 0224-E**



The information contained in this catalogue is subject to change without notice for the purpose of product improvement



**IAI Industrieroboter GmbH**

Ober der Röth 4  
D-65824 Schwalbach / Frankfurt  
Germany

Phone: +49-6196-8895-0

Fax: +49-6196-8895-24

E-Mail: [info@IAI-automation.com](mailto:info@IAI-automation.com)

Internet: [IAI-automation.com](http://IAI-automation.com)

---

**IAI America, Inc.**

2690 W. 237th Street, Torrance, CA 90505, U.S.A  
Phone: +1-310-891-6015, Fax: +1-310-891-0815

**IAI (Shanghai) Co., Ltd**

Shanghai Jiahua Business Center A8-303, 808,  
Hongqiao Rd., Shanghai 200030, China  
Phone: +86-21-6448-4753, Fax: +86-21-6448-3992

**IAI CORPORATION**

577-1 Obane, Shimizu-Ku, Shizuoka, 424-0103 Japan  
Phone: +81-543-64-5105, Fax: +81-543-64-5192

**IAI Robot (Thailand) Co., Ltd**

825 PhairojKijja Tower 12th Floor, Bangna-Trad RD.,  
Bangna, Bangna, Bangkok 10260, Thailand  
Phone: +66-2-361-4457, Fax: +66-2-361-4456