

Simple-to-use ELECYLINDER with Built-in Controller
Large Slider Type with 230 VAC Servo Motor

EC S10/13/15

Simple-to-use ELECYLINDER with Built-in Controller
Large Slider Mid-support Type with 230 VAC Servo Motor

EC S10/13/15X

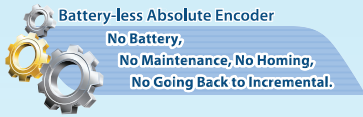

EC ELECYLINDER



Simple & Wireless
Operation

2 Position Actuator

2-point positioning

Built-in controller

EleCylinder

EC-S10(X)/S13(X)/S15(X)

Large Slider Type

1

Maximum stroke **2500mm**

Maximum speed **2000mm/s**

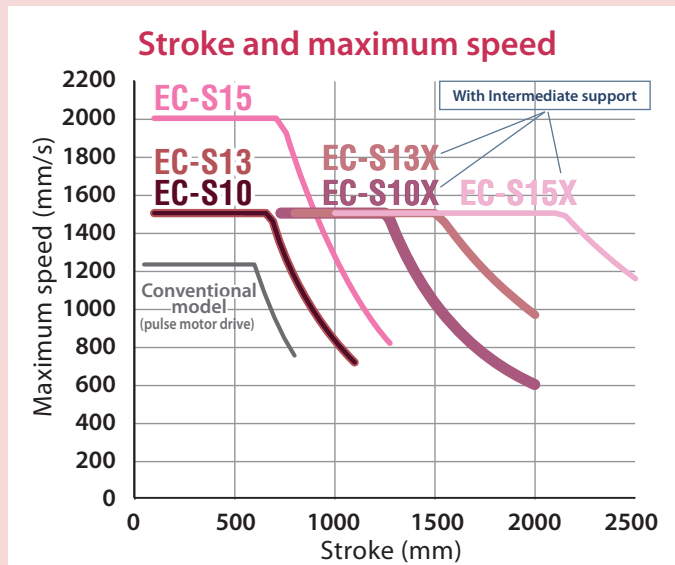

Equipped with high output 230 VAC servo motors.

A model with intermediate support is also available. Compared to the conventional pulse motor model this large slider type has a longer stroke and operates at higher speeds.

EC-S15X

2500mm Stroke

2

Maximum payload

108kg

Correlation between speed and payload

(acceleration/deceleration 0.3G)

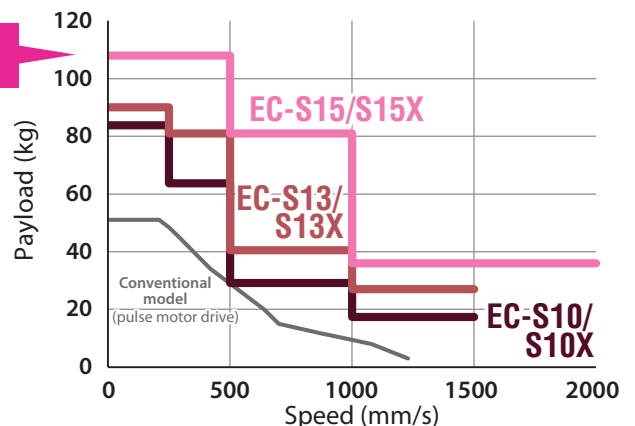

3

Standard-equipped with battery-less absolute encoder

No home return is required, which shortens the startup time with long stroke.

4

Double slider specification is available as an option

Can be used for longer overhang and higher moment loading.

5

New intermediate support

New mechanism is adopted for intermediate support. A long stroke is possible even for vertical installations.

Horizontal flat

Horizontal side

Horizontal ceiling

Vertical

6

Can be installed with bolts from the top face

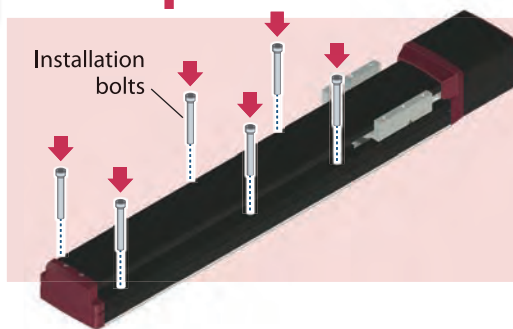

Installation bolts

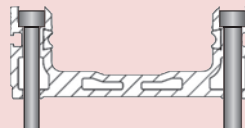

Installation bolt size
S10(X): M6
S13(X)/S15(X): M8

7

Compatible with wireless teaching

Allowing test runs from a distance



TB-03

8

Motor drive DC power unit can supply power up to 6 axes

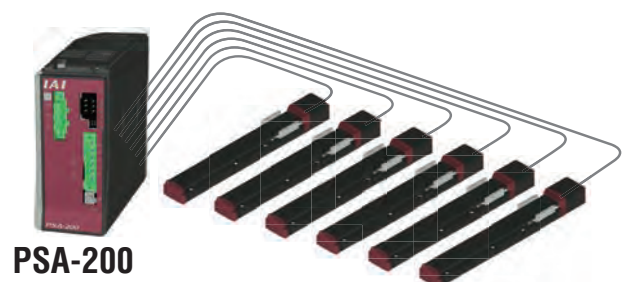

PSA-200

Model Specifications Items

EleCylinder

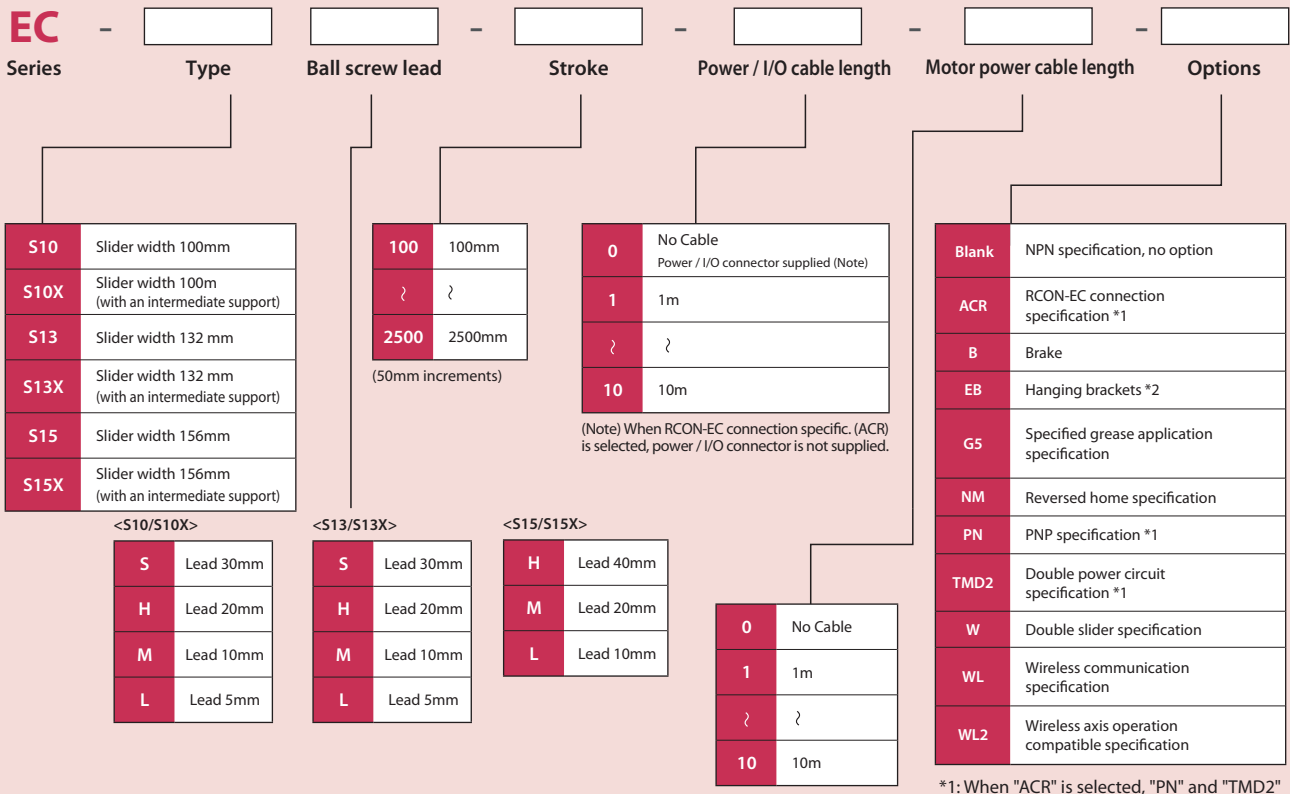

* Depending on the actuator type, stroke selection range varies. For details, refer to the page for each type.





*1: When "ACR" is selected, "PN" and "TMD2" cannot be selected.

*2: Only S15X type can be selected.

Notes on Installation

Installation orientation

○ : Installation possible
 – : Installation impossible

		Installation orientation			
					
Series	Type	Horizontal flat	Horizontal side	Horizontal ceiling	Vertical
EC	S10	○	○*1	○	○*2*3
	S10X				
	S13				
	S13X				
	S15				
	S15X				

*1 For horizontal side installations may drip oil components that become separated from the grease.
 Also parts and other materials can enter the side face of this actuator.
 If necessary, use the actuator with protective parts attached.

*2 For vertical installation, it is recommended to mount the motor above the ball screw.
 If the motor is mounted below the ball screw; the motor, controller and encoder can become damaged from base oil flowing down into that area.

*3 When the actuator is installed with the motor on the top side, attach a cap on the teaching port.
 Foreign matters might get stuck in the teaching port, which may cause a malfunction.

■ The flatness of the main body installation face and work mounting surface shall be within 0.05 mm/m.
 If the flatness exceeds the tolerance, slider sliding resistance becomes higher, which may cause an operation failure.

EC-S10

Large Slider Type

±10μm Standard

Battery-less Absolute

Motor Unit Coupled

Straight Motor

Body Width 100mm

230V AC Servo Motor

Model items

EC - **S10** [] - [] - [] - [] - []

Series	Type	Lead	Stroke	Power/IO cable length	Motor power cable length	Option
		S 30mm H 20mm M 10mm L 5mm	100 100mm 1100 1100mm (50-mm increments)	Please see cable length table below.	0 No cable 1 1m 2 2m 10 10m	Please see options table below.

RoHS

Horizontal

Vertical

Side

Ceiling



POINT
Selection Notes

(1) As the stroke length increases, the speed decreases due to excessive vibration of the ballscrew. Please confirm the maximum speed at the desired stroke using the "stroke and max. speed" table.

(2) The payload of "main specification" shows the maximum value. For details, refer to the "table of payload by speed/acceleration."

(3) For these actuators to operate the DC motor drive power unit "PSA-200" is necessary. One "PSA-200" can supply power up to 6 axes. For details, refer to page 34.

(4) Depending on the operation condition (payload, acceleration/deceleration), rough guide for available duty ratio varies. For details, refer to page 30.

(5) Pay close attention to the installation orientation. Refer to page 4 for details.

(6) Rough guide for overhang load length is 550mm or less (780mm or less for double slider specification) in Ma/Mb/Mc directions.

Power / I/O Cable Length

Cable code	Cable length	User wiring specification	RCON-EC connection specification (*2)
		Discrete wiring	With connectors at both ends
0	No cable	Terminal block supplied (*1)	CB-REC-PWBIO□□□-RB supplied
1~3	1~3m	CB-EC-PWBIO□□□-RB supplied	
4~5	4~5m		
6~7	6~7m		
8~10	8~10m		

(*1) When „No cable“ is selected only terminal block connector is supplied. For details, refer to page 33.
 (*2) This applies when RCON-EC connection specification (ACR) is selected as an option.
 (Note) These are robot cables.

Motor Power Cable Length

Cable code	Cable length	User wiring / RCON-EC connection specific.
0	No cable	CB-EC-PW□□□-RB supplied
1~3	1~3m	
4~5	4~5m	
6~10	6~10m	

(Note) These are robot cables.

Option

Name	Option code	Reference page
RCON-EC connection specification (Note 1)	ACR	29
Brake	B	29
Specified grease application specification	GS	29
Reversed-home specification	NM	29
PNP specification (Note 1)	PN	29
Double power circuit specification (Note 1)	TMD2	29
Double slider specification (Note 2)	W	29
Wireless communication specification	WL	29
Wireless axis operation compatible specification	WL2	29

(Note 1) When RCON-EC connection specification (ACR) is selected, PNP specification (PN) or double power circuit specification (TMD2) cannot be selected.
 (Note 2) The allowable payload, dimensions, and body mass will be different for the double slider specification.

Main Specifications

Item		Details				
Lead	Ball screw lead (mm)	30	20	10	5	
Horizontal	Payload	Maximum payload (kg) (*1)	17	30	65	85
		Maximum speed (mm/s)	1500	1000	500	250
	Speed/acceleration/deceleration (G)	Rated acceleration/deceleration (G)	0.3	0.3	0.3	0.3
		Maximum acceleration/deceleration (G)	1	1	0.7	0.3
Vertical	Payload	Maximum payload (kg) (*1)	2	5	11	21
		Maximum speed (mm/s)	1500	1000	500	250
	Speed/acceleration/deceleration (G)	Rated acceleration/deceleration (G)	0.3	0.3	0.3	0.3
		Maximum acceleration/deceleration (G)	0.7	0.7	0.5	0.3
Thrust	Rated thrust (N)	56.5	84.9	169.8	339.7	
Brake	Brake specification	Non-excited operation electromagnetic brake				
	Brake retaining force (kgf)	2	5	11	21	
Stroke	Minimum stroke (mm)	100	100	100	100	
	Maximum stroke (mm)	1100	1100	1100	1100	
	Stroke pitch (mm)	50	50	50	50	

(*1) The maximum payload decreases when the double slider specification (W) is selected. See the table below.

Item	Details
Drive method	Ball screw ø16 mm rolled C10 equivalent
Positioning repeatability	±0.01mm
Lost motion	—
Base	Dedicated extruded aluminum (A6063S-T6 equivalent), black alumite treatment
Linear guide	Linear motion endlessly circulating type
Static allowable moment (*2)	Ma: 328 N·m [1770 N·m]
	Mb: 328 N·m [1770 N·m]
	Mc: 631 N·m [1260 N·m]
Dynamic allowable moment (*2) (*3)	Ma: 61.1 N·m [268 N·m]
	Mb: 61.1 N·m [268 N·m]
	Mc: 117 N·m [191 N·m]
Ambient operating air temperature, humidity	0 to 40°C, 85%RH max. (no condensation)
Protection class	—
Vibration resistance/shock resistance	4.9m/s ²
Overseas standard compliance	CE Marking, RoHS Directive
Motor type	AC servo motor (230 V)
Rated motor capacity	100W
Encoder type	Battery-less absolute
Encoder pulse count	16384 pulse/rev

(*2) Values in the brackets [] are for the double slider specification (W).

(*3) Based on the assumption of a standard rated life of 10000 km. The traveling life varies depending on the operating conditions and installation conditions.

Slider type moment direction

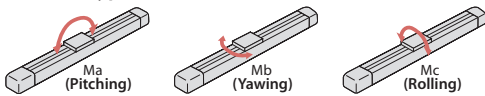

Table of Payload by Speed/Acceleration

Payload shown in units of kg.

Lead 30

Orientation Speed (mm/s)	Horizontal			Vertical			
	Acceleration (G)						
	0.3	0.5	0.7	1.0	0.3	0.5	0.7
0	17	11	7.5	4.5	2	2	2
1500	17	11	7.5	4.5	2	2	2

Lead 20

Orientation Speed (mm/s)	Horizontal			Vertical			
	Acceleration (G)						
	0.3	0.5	0.7	1.0	0.3	0.5	0.7
0	30	19.5	12.5	7.5	5	4.5	3.5
1000	30	19.5	12.5	7.5	5	4.5	3.5

Lead 10

Orientation Speed (mm/s)	Horizontal			Vertical		
	Acceleration (G)					
	0.3	0.5	0.7	0.3	0.5	0.5
0	65	33	19	11	9	9
500	65	33	19	11	9	9

Lead 5

Orientation Speed (mm/s)	Horizontal	Vertical
	Acceleration (G)	
	0.3	0.3
0	85	21
250	85	21

Table of Payload by Speed/Acceleration (double slider specification)

Payload shown in units of kg. Blank cells mean the actuator cannot be operated under those conditions.

Lead 30

Orientation Speed (mm/s)	Horizontal			Vertical			
	Acceleration (G)						
	0.3	0.5	0.7	1.0	0.3	0.5	0.7
0	12	6	2.5				
1500	12	6	2.5				

Lead 20

Orientation Speed (mm/s)	Horizontal			Vertical			
	Acceleration (G)						
	0.3	0.5	0.7	1.0	0.3	0.5	0.7
0	25	14.5	7.5	2.5			
1000	25	14.5	7.5	2.5			

Lead 10

Orientation Speed (mm/s)	Horizontal			Vertical		
	Acceleration (G)					
	0.3	0.5	0.7	0.3	0.5	0.5
0	60	28	14	6	4	4
500	60	28	14	6	4	4

Lead 5

Orientation Speed (mm/s)	Horizontal	Vertical
	Acceleration (G)	
	0.3	0.3
0	80	16
250	80	16

Stroke and maximum speed

Stroke	100 ~ 700 (50-mm increment)	750 (mm)	800 (mm)	850 (mm)	900 (mm)	950 (mm)	1000 (mm)	1050 (mm)	1100 (mm)
30	1500	1328	1187	1068	965	877	800	733	674
20	1000	886	792	712	644	585	533	489	449
10	500	443	396	356	322	292	267	244	225
5	250	221	198	178	161	146	133	122	112

(Unit: mm/s)

Dimensions

(Note) The slider moves to the M.E. during home return. Pay attention to prevent contact between the slider and surrounding parts.

CAD drawings can be downloaded from our website.
www.elecylinder.de



ST: Stroke
M.E.: Mechanical end
S.E.: Stroke end

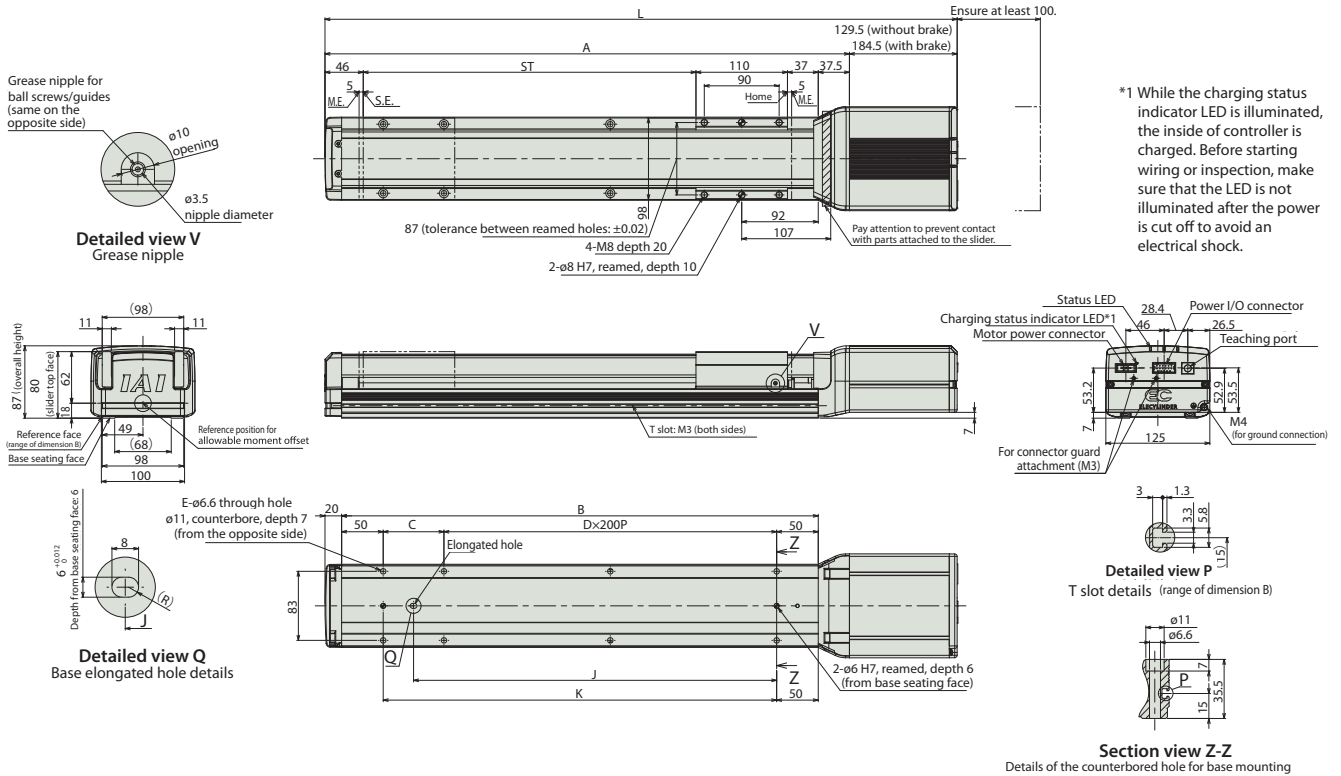

*1 While the charging status indicator LED is illuminated, the inside of controller is charged. Before starting wiring or inspection, make sure that the LED is not illuminated after the power is cut off to avoid an electrical shock.

Dimension by stroke

Stroke	100	150	200	250	300	350	400	450	500	550	600	650	700	750	800	850	900	950	1000	1050	1100	
L	Without brake	460	510	560	610	660	710	760	810	860	910	960	1010	1060	1110	1160	1210	1260	1310	1360	1410	1460
	With brake	515	565	615	665	715	765	815	865	915	965	1015	1065	1115	1165	1215	1265	1315	1365	1415	1465	1515
A	330.5	380.5	430.5	480.5	530.5	580.5	630.5	680.5	730.5	780.5	830.5	880.5	930.5	980.5	1030.5	1080.5	1130.5	1180.5	1230.5	1280.5	1330.5	
B	273	323	373	423	473	523	573	623	673	723	773	823	873	923	973	1023	1073	1123	1173	1223	1273	
C	173	223	273	123	173	223	73	123	173	223	73	123	173	223	73	123	173	223	73	123	173	
D	0	0	0	1	1	1	2	2	2	3	3	3	3	4	4	4	4	5	5	5	5	
E	4	4	4	6	6	6	8	8	8	8	10	10	10	10	12	12	12	12	14	14	14	
J	86.5	111.5	136.5	261.5	286.5	311.5	436.5	461.5	486.5	511.5	636.5	661.5	686.5	711.5	836.5	861.5	886.5	911.5	1036.5	1061.5	1086.5	
K	173	223	273	323	373	423	473	523	573	623	673	723	773	823	873	923	973	1023	1073	1123	1173	

Weight by stroke

Stroke	100	150	200	250	300	350	400	450	500	550	600	650	700	750	800	850	900	950	1000	1050	1100	
Weight (kg)	Without brake	4.5	4.8	5.2	5.5	5.9	6.2	6.6	6.9	7.3	7.6	7.9	8.3	8.6	9.0	9.3	9.7	10.0	10.4	10.7	11.1	11.4
	With brake	5.1	5.4	5.8	6.1	6.5	6.8	7.2	7.5	7.9	8.2	8.5	8.9	9.2	9.6	9.9	10.3	10.6	11.0	11.3	11.7	12.0

Dimensions (double slider specification)

(Note) The slider moves to the M.E. during home return. Pay attention to prevent contact between the slider and surrounding parts.

CAD drawings can be downloaded from our website.
www.elecylinder.de



ST: Stroke
M.E.: Mechanical end
S.E.: Stroke end

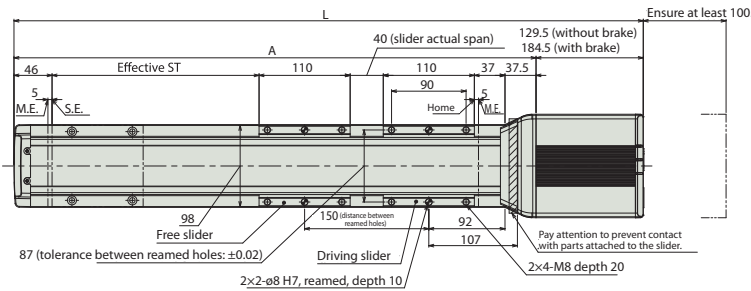
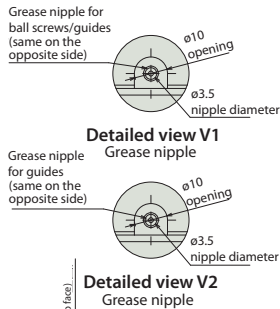

*1 While the charging status indicator LED is illuminated, the inside of controller is charged. Before starting wiring or inspection, make sure that the LED is not illuminated after the power is cut off to avoid an electrical shock.

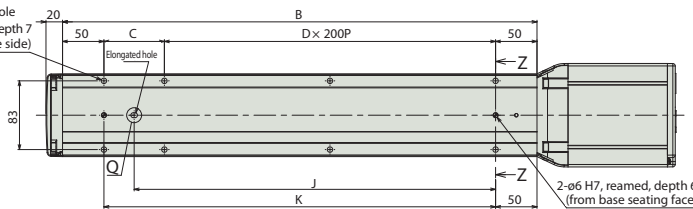
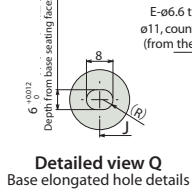
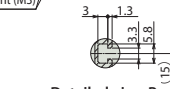
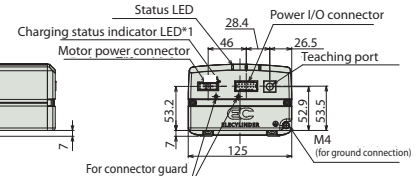
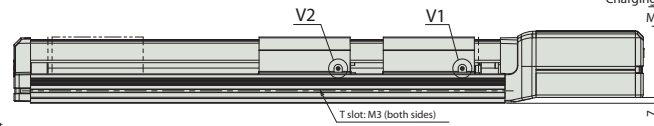
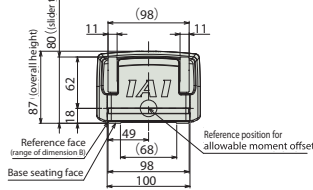

Dimension by stroke

Nominal stroke	250	300	350	400	450	500	550	600	650	700	750	800	850	900	950	1000	1050	1100	
Effective stroke	100	150	200	250	300	350	400	450	500	550	600	650	700	750	800	850	900	950	
L	Without brake	610	660	710	760	810	860	910	960	1010	1060	1110	1160	1210	1260	1310	1360	1410	1460
	With brake	665	715	765	815	865	915	965	1015	1065	1115	1165	1215	1265	1315	1365	1415	1465	1515
A	480.5	530.5	580.5	630.5	680.5	730.5	780.5	830.5	880.5	930.5	980.5	1030.5	1080.5	1130.5	1180.5	1230.5	1280.5	1330.5	
B	423	473	523	573	623	673	723	773	823	873	923	973	1023	1073	1123	1173	1223	1273	
C	123	173	223	73	123	173	223	73	123	173	223	73	123	173	223	73	123	173	
D	1	1	1	2	2	2	2	3	3	3	3	4	4	4	4	5	5	5	
E	6	6	6	8	8	8	8	10	10	10	10	12	12	12	12	14	14	14	
J	261.5	286.5	311.5	436.5	461.5	486.5	511.5	636.5	661.5	686.5	711.5	836.5	861.5	886.5	911.5	1036.5	1061.5	1086.5	
K	323	373	423	473	523	573	623	673	723	773	823	873	923	973	1023	1073	1123	1173	

(Note) Nominal stroke: stroke specified in the model code.
Effective stroke: actual operable stroke

Weight by stroke

Nominal stroke	250	300	350	400	450	500	550	600	650	700	750	800	850	900	950	1000	1050	1100	
Effective stroke	100	150	200	250	300	350	400	450	500	550	600	650	700	750	800	850	900	950	
Weight (kg)	Without brake	7.0	7.4	7.7	8.1	8.4	8.8	9.1	9.4	9.8	10.1	10.5	10.8	11.2	11.5	11.9	12.2	12.6	12.9
	With brake	7.6	8.0	8.3	8.7	9.0	9.4	9.7	10.0	10.4	10.7	11.1	11.4	11.8	12.1	12.5	12.8	13.2	13.5

(Note) The inclusion of the free slider adds 1.5kg to the actuator weight compared to the single slider specification.

Compatible controller

(Note) The EC series uses a built-in controller. For details about the built-in controller, refer to page 32.
The "PSA-200" DC motor power unit is required for any EleCylinder that uses 230V servo motors. Refer to page 34 for details about the PSA-200.

EC-S10X (with an intermediate support)

Large Slider Type

Intermediate SUPPORT

±10μm Standard

Battery-less Absolute

Motor Unit Coupled

Straight Motor

Body Width 100 mm

230v AC Servo Motor

Model items

EC - S10X [] - [] - [] - [] - []

Series	Type	Lead	Stroke	Power/IO cable length	Motor power cable length	Option																								
		<table border="1" style="width: 100%; border-collapse: collapse;"> <tr><td>S</td><td>30mm</td></tr> <tr><td>H</td><td>20mm</td></tr> <tr><td>M</td><td>10mm</td></tr> <tr><td>L</td><td>5mm</td></tr> </table>	S	30mm	H	20mm	M	10mm	L	5mm	<table border="1" style="width: 100%; border-collapse: collapse;"> <tr><td>700</td><td>700mm</td></tr> <tr><td>2000</td><td>2000mm (50-mm increments)</td></tr> </table>	700	700mm	2000	2000mm (50-mm increments)	<table border="1" style="width: 100%; border-collapse: collapse;"> <tr><td colspan="2">Please see cable length table below.</td></tr> </table>	Please see cable length table below.		<table border="1" style="width: 100%; border-collapse: collapse;"> <tr><td>0</td><td>No cable</td></tr> <tr><td>1</td><td>1m</td></tr> <tr><td>2</td><td>2m</td></tr> <tr><td>10</td><td>10m</td></tr> </table>	0	No cable	1	1m	2	2m	10	10m	<table border="1" style="width: 100%; border-collapse: collapse;"> <tr><td colspan="2">Please see options table below.</td></tr> </table>	Please see options table below.	
S	30mm																													
H	20mm																													
M	10mm																													
L	5mm																													
700	700mm																													
2000	2000mm (50-mm increments)																													
Please see cable length table below.																														
0	No cable																													
1	1m																													
2	2m																													
10	10m																													
Please see options table below.																														

RoHS

Horizontal

Vertical

Side

Ceiling



(1) As the stroke length increases, the speed decreases due to excessive vibration of the ballscrew. Please confirm the maximum speed at the desired stroke using the "stroke and max. speed" table.

(2) The payload of "main specification" shows the maximum value. For details, refer to the "table of payload by speed/acceleration."

(3) For these actuators to operate the DC motor drive power unit "PSA-200" is necessary. One "PSA-200" can supply power up to 6 axes. For details, refer to page 34.

(4) Depending on the operation condition (payload, acceleration/deceleration), rough guide for available duty ratio varies. For details, refer to page 30.

(5) Pay close attention to the installation orientation. Refer to page 4 for details.

(6) Rough guide for overhang load length is 550mm or less (795mm or less for double slider specification) in Ma/Mb/Mc directions.

(7) For the intermediate support type, a collision sound occurs during operation due to the structure of support mechanism.

Power / I/O Cable Length

Cable code	Cable length	User wiring specification	RCON-EC connection specification (*2)
		Discrete wiring	With connectors at both ends
0	No cable	Terminal block supplied (*1)	CB-REC-PWBIO□□□-RB supplied
1~3	1~3m	CB-EC-PWBIO□□□-RB supplied	
4~5	4~5m		
6~7	6~7m		
8~10	8~10m		

(*1) When „No cable“ is selected only terminal block connector is supplied. For details, refer to page 33.
 (*2) This applies when RCON-EC connection specification (ACR) is selected as an option.
 (Note) These are robot cables.

Motor Power Cable Length

Cable code	Cable length	User wiring / RCON-EC connection specific.
0	No cable	CB-EC-PW□□□-RB supplied
1~3	1~3m	
4~5	4~5m	
6~10	6~10m	

(Note) These are robot cables.

Option

Name	Option code	Reference page
RCON-EC connection specification (Note 1)	ACR	29
Brake	B	29
Specified grease application specification	GS	29
Reversed-home specification	NM	29
PNP specification (Note 1)	PN	29
Double power circuit specification (Note 1)	TMD2	29
Double slider specification (Note 2)	W	29
Wireless communication specification	WL	29
Wireless axis operation compatible specification	WL2	29

(Note 1) When RCON-EC connection specification (ACR) is selected, PNP specification (PN) or double power circuit specification (TMD2) cannot be selected.
 (Note 2) The allowable payload, dimensions, and body mass will be different for the double slider specification.

Main Specifications

Item		Details				
Lead	Ball screw lead (mm)	30	20	10	5	
Horizontal	Payload	Maximum payload (kg) (*1)	17	30	65	85
		Maximum speed (mm/s)	1500	1000	500	250
	Speed/acceleration/deceleration	Rated acceleration/deceleration (G)	0.3	0.3	0.3	0.3
		Maximum acceleration/deceleration (G)	1	1	0.7	0.3
Vertical	Payload	Maximum payload (kg) (*1)	2	5	11	21
		Maximum speed (mm/s)	1500	1000	500	250
	Speed/acceleration/deceleration	Rated acceleration/deceleration (G)	0.3	0.3	0.3	0.3
		Maximum acceleration/deceleration (G)	0.7	0.7	0.5	0.3
Thrust	Rated thrust (N)	56.5	84.9	169.8	339.7	
Brake	Brake specification	Non-excited operation electromagnetic brake				
	Brake retaining force (kgf)	2	5	11	21	
Stroke	Minimum stroke (mm)	700	700	700	700	
	Maximum stroke (mm)	2000	2000	2000	2000	
	Stroke pitch (mm)	50	50	50	50	

Item	Details
Drive method	Ball screw ø16 mm rolled C10 equivalent
Positioning repeatability	±0.01mm
Lost motion	—
Base	Dedicated extruded aluminum (A6063S5-T6 equivalent), black alumite treatment
Linear guide	Linear motion endlessly circulating type
Static allowable moment (*2)	Ma: 328 N·m [1840 N·m]
	Mb: 328 N·m [1840 N·m]
	Mc: 631 N·m [1260 N·m]
Dynamic allowable moment (*2) (*3)	Ma: 61.1 N·m [279 N·m]
	Mb: 61.1 N·m [279 N·m]
	Mc: 117 N·m [191 N·m]
Ambient operating air temperature, humidity	0 to 40°C, 85%RH max. (no condensation)
Protection class	—
Vibration resistance/shock resistance	4.9m/s ²
Overseas standard compliance	CE Marking, RoHS Directive
Motor type	AC servo motor (230 V)
Rated motor capacity	100W
Encoder type	Battery-less absolute
Encoder pulse count	16384 pulse/rev

(*1) The maximum payload decreases when the double slider specification (W) is selected. See the table below.

Slider type moment direction

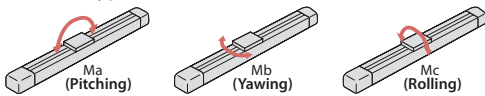

(*2) Values in the brackets [] are for the double slider specification (W).

(*3) Based on the assumption of a standard rated life of 10000 km. The traveling life varies depending on the operating conditions and installation conditions.

Table of Payload by Speed/Acceleration

Payload shown in units of kg.

Lead 30

Orientation	Horizontal		Vertical					
	Acceleration (G)							
	Speed (mm/s)		0.3	0.5	0.7	1.0	0.3	0.5
0	17	11	7.5	4.5	2	2	2	2
1500	17	11	7.5	4.5	2	2	2	2

Lead 20

Orientation	Horizontal		Vertical					
	Acceleration (G)							
	Speed (mm/s)		0.3	0.5	0.7	1.0	0.3	0.5
0	30	19.5	12.5	7.5	5	4.5	3.5	3.5
1000	30	19.5	12.5	7.5	5	4.5	3.5	3.5

Lead 10

Orientation	Horizontal		Vertical				
	Acceleration (G)						
	Speed (mm/s)		0.3	0.5	0.7	0.3	0.5
0	65	33	19	11	9	9	9
500	65	33	19	11	9	9	9

Lead 5

Orientation	Horizontal	Vertical
	Acceleration (G)	
	0.3	0.3
0	85	21
250	85	21

Table of Payload by Speed/Acceleration (double slider specification)

Payload shown in units of kg. Blank cells mean the actuator cannot be operated under those conditions.

Lead 30

Orientation	Horizontal		Vertical					
	Acceleration (G)							
	Speed (mm/s)		0.3	0.5	0.7	1.0	0.3	0.5
0	12	6	2.5					
1500	12	6	2.5					

Lead 20

Orientation	Horizontal		Vertical					
	Acceleration (G)							
	Speed (mm/s)		0.3	0.5	0.7	1.0	0.3	0.5
0	25	14.5	7.5	2.5				
1000	25	14.5	7.5	2.5				

Lead 10

Orientation	Horizontal		Vertical				
	Acceleration (G)						
	Speed (mm/s)		0.3	0.5	0.7	0.3	0.5
0	60	28	14	6	4	4	4
500	60	28	14	6	4	4	4

Lead 5

Orientation	Horizontal	Vertical
	Acceleration (G)	
	0.3	0.3
0	80	16
250	80	16

Stroke and maximum speed

Stroke	700 ~ 1250	1300	1350	1400	1450	1500	1550	1600	1650	1700	1750	1800	1850	1900	1950	2000
Lead (mm)	(50-mm increment)	(mm)	(mm)	(mm)	(mm)	(mm)	(mm)	(mm)	(mm)	(mm)	(mm)	(mm)	(mm)	(mm)	(mm)	(mm)
30	1500	1429	1328	1236	1154	1080	1013	952	896	845	798	755	715	679	645	614
20	1000	953	885	824	770	720	675	634	597	563	532	503	477	453	430	409
10	500	476	443	412	385	360	338	317	299	282	266	252	238	226	215	205
5	250	238	221	206	192	180	169	159	149	141	133	126	119	113	107	102

(Unit: mm/s)

Dimensions

(Note) The slider moves to the M.E. during home return. Pay attention to prevent contact between the slider and surrounding parts.

CAD drawings can be downloaded from our website.
www.elecylinder.de



ST: Stroke
M.E.: Mechanical end
S.E.: Stroke end

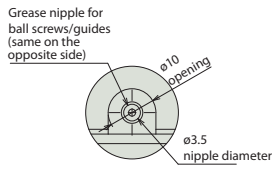

Detailed view V
Grease nipple

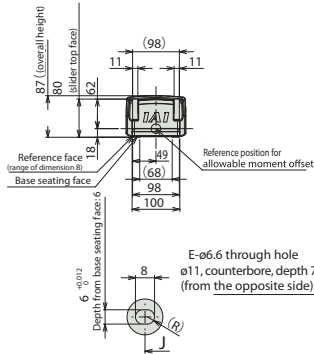

Detailed view Q
Base elongated hole details

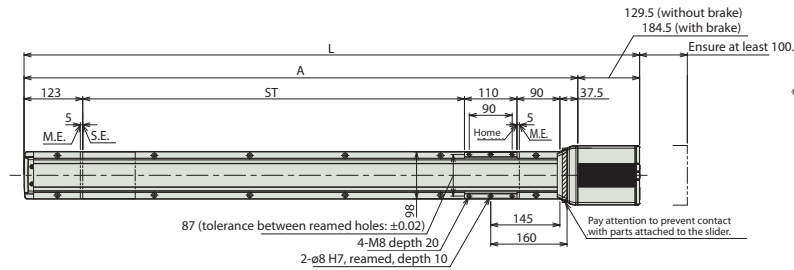

*1 While the charging status indicator LED is illuminated, the inside of controller is charged. Before starting wiring or inspection, make sure that the LED is not illuminated after the power is cut off to avoid an electrical shock.

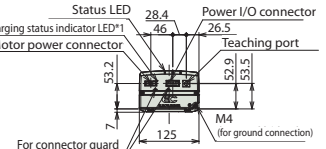
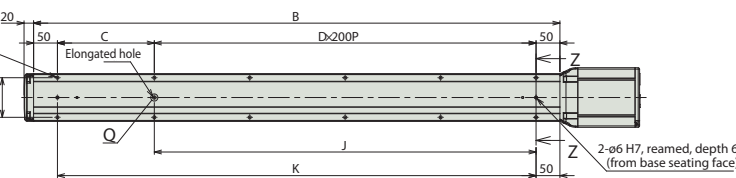
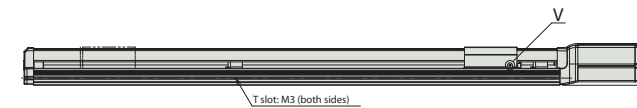

Detailed view P
T slot details (range of dimension B)

Section view Z-Z
Details of the counterbored hole for base

Dimension by stroke

Stroke	700	750	800	850	900	950	1000	1050	1100	1150	1200	1250	1300	1350	1400	1450	1500	1550	1600	1650	1700	1750	1800	1850	1900	1950	2000		
L	Without brake	1190	1240	1290	1340	1390	1440	1490	1540	1590	1640	1690	1740	1790	1840	1890	1940	1990	2040	2090	2140	2190	2240	2290	2340	2390	2440	2490	
	With brake	1245	1295	1345	1395	1445	1495	1545	1595	1645	1695	1745	1795	1845	1895	1945	1995	2045	2095	2145	2195	2245	2295	2345	2395	2445	2495	2545	
A	1060.5	1110.5	1160.5	1210.5	1260.5	1310.5	1360.5	1410.5	1460.5	1510.5	1560.5	1610.5	1660.5	1710.5	1760.5	1810.5	1860.5	1910.5	1960.5	2010.5	2060.5	2110.5	2160.5	2210.5	2260.5	2310.5	2360.5	2410.5	2460.5
B	1003	1053	1103	1153	1203	1253	1303	1353	1403	1453	1503	1553	1603	1653	1703	1753	1803	1853	1903	1953	2003	2053	2103	2153	2203	2253	2303	2353	2403
C	103	153	203	253	303	353	403	453	503	553	603	653	703	753	803	853	903	953	1003	1053	1103	1153	1203	1253	1303	1353	1403	1453	1503
D	4	4	4	4	5	5	5	5	6	6	6	6	7	7	7	7	8	8	8	8	9	9	9	9	10	10	10	10	10
E	12	12	12	12	14	14	14	14	16	16	16	16	18	18	18	18	20	20	20	20	22	22	22	22	24	24	24	24	24
J	800	800	800	800	1000	1000	1000	1000	1200	1200	1200	1200	1400	1400	1400	1400	1600	1600	1600	1600	1800	1800	1800	1800	2000	2000	2000	2000	2000
K	903	953	1003	1053	1103	1153	1203	1253	1303	1353	1403	1453	1503	1553	1603	1653	1703	1753	1803	1853	1903	1953	2003	2053	2103	2153	2203	2253	2303

Weight by stroke

Stroke	700	750	800	850	900	950	1000	1050	1100	1150	1200	1250	1300	1350	1400	1450	1500	1550	1600	1650	1700	1750	1800	1850	1900	1950	2000	
Weight (kg)	Without brake	10.3	10.6	11.0	11.3	11.7	12.0	12.4	12.8	13.1	13.5	13.8	14.2	14.5	14.9	15.2	15.6	15.9	16.3	16.7	17.0	17.4	17.7	18.1	18.4	18.8	19.1	19.5
	With brake	10.9	11.2	11.6	11.9	12.3	12.6	13.0	13.4	13.7	14.1	14.4	14.8	15.1	15.5	15.8	16.2	16.5	16.9	17.3	17.6	18.0	18.3	18.7	19.0	19.4	19.7	20.1

Dimensions (double slider specification)

(Note) The slider moves to the M.E. during home return. Pay attention to prevent contact between the slider and surrounding parts.

CAD drawings can be downloaded from our website.
www.elecylinder.de



ST: Stroke
M.E.: Mechanical end
S.E.: Stroke end

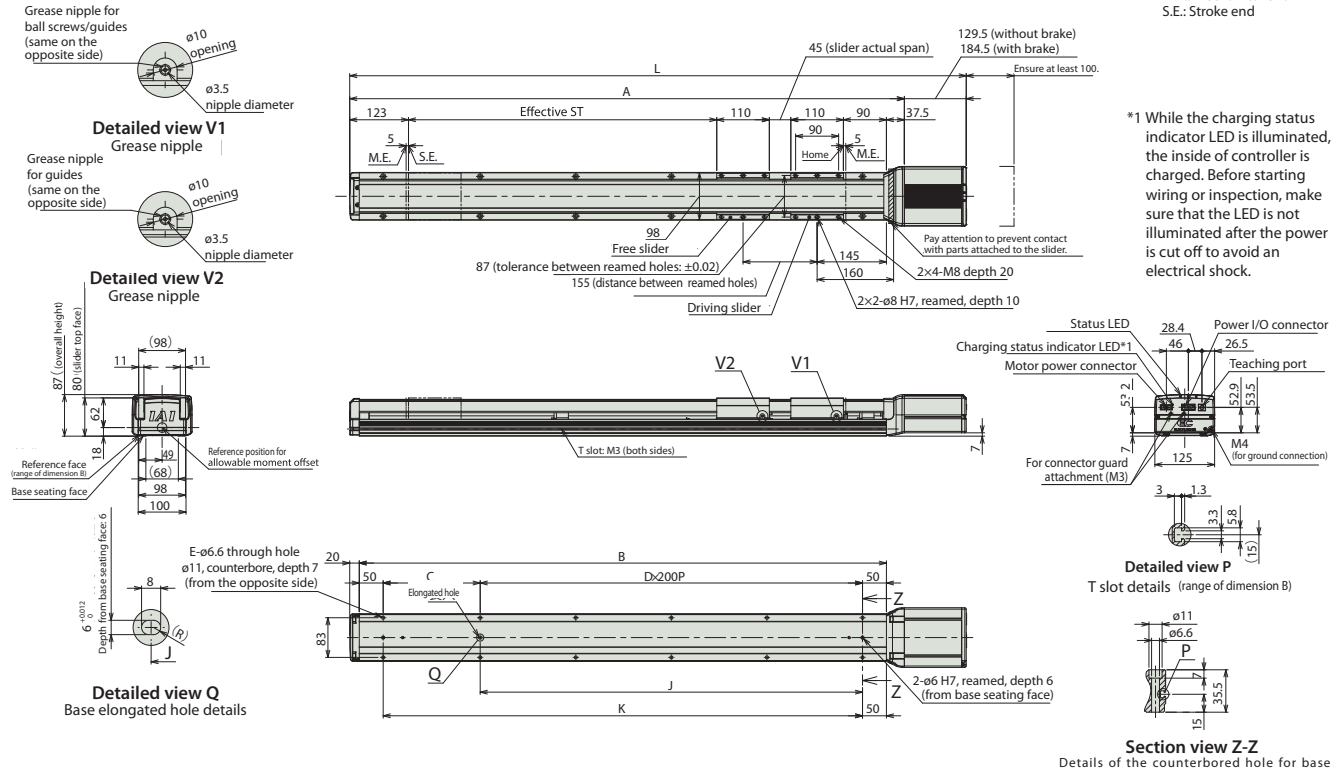

*1 While the charging status indicator LED is illuminated, the inside of controller is charged. Before starting wiring or inspection, make sure that the LED is not illuminated after the power is cut off to avoid an electrical shock.

Dimension by stroke

Nominal stroke	700	750	800	850	900	950	1000	1050	1100	1150	1200	1250	1300	1350	1400	1450	1500	1550	1600	1650	1700	1750	1800	1850	1900	1950	2000	
Effective stroke	545	595	645	695	745	795	845	895	945	995	1045	1095	1145	1195	1245	1295	1345	1395	1445	1495	1545	1595	1645	1695	1745	1795	1845	
L	Without brake	1190	1240	1290	1340	1390	1440	1490	1540	1590	1640	1690	1740	1790	1840	1890	1940	1990	2040	2090	2140	2190	2240	2290	2340	2390	2440	2490
	With brake	1245	1295	1345	1395	1445	1495	1545	1595	1645	1695	1745	1795	1845	1895	1945	1995	2045	2095	2145	2195	2245	2295	2345	2395	2445	2495	2545
A	1060.5	1110.5	1160.5	1210.5	1260.5	1310.5	1360.5	1410.5	1460.5	1510.5	1560.5	1610.5	1660.5	1710.5	1760.5	1810.5	1860.5	1910.5	1960.5	2010.5	2060.5	2110.5	2160.5	2210.5	2260.5	2310.5	2360.5	
B	1003	1053	1103	1153	1203	1253	1303	1353	1403	1453	1503	1553	1603	1653	1703	1753	1803	1853	1903	1953	2003	2053	2103	2153	2203	2253	2303	
C	103	153	203	253	303	353	403	453	503	553	603	653	703	753	803	853	903	953	1003	1053	1103	1153	1203	1253	1303	1353	1403	
D	4	4	4	4	5	5	5	5	6	6	6	6	7	7	7	7	8	8	8	8	9	9	9	9	10	10	10	
E	12	12	12	12	14	14	14	14	16	16	16	16	18	18	18	18	20	20	20	20	22	22	22	22	24	24	24	
J	800	800	800	800	1000	1000	1000	1000	1200	1200	1200	1200	1400	1400	1400	1400	1600	1600	1600	1600	1800	1800	1800	1800	2000	2000	2000	
K	903	953	1003	1053	1103	1153	1203	1253	1303	1353	1403	1453	1503	1553	1603	1653	1703	1753	1803	1853	1903	1953	2003	2053	2103	2153	2203	

(Note) Nominal stroke: stroke specified in the model code.
Effective stroke: actual operable stroke

Weight by stroke

Nominal stroke	700	750	800	850	900	950	1000	1050	1100	1150	1200	1250	1300	1350	1400	1450	1500	1550	1600	1650	1700	1750	1800	1850	1900	1950	2000	
Effective stroke	545	595	645	695	745	795	845	895	945	995	1045	1095	1145	1195	1245	1295	1345	1395	1445	1495	1545	1595	1645	1695	1745	1795	1845	
Weight (kg)	Without brake	11.8	12.1	12.5	12.8	13.2	13.5	13.9	14.3	14.6	15.0	15.3	15.7	16.0	16.4	16.7	17.1	17.4	17.8	18.2	18.5	18.9	19.2	19.6	19.9	20.3	20.6	21.0
	With brake	12.4	12.7	13.1	13.4	13.8	14.1	14.5	14.9	15.2	15.6	15.9	16.3	16.6	17.0	17.3	17.7	18.0	18.4	18.8	19.1	19.5	19.8	20.2	20.5	20.9	21.2	21.6

(Note) The inclusion of the free slider adds 1.5kg to the actuator weight compared to the single slider specification.

Compatible controller

(Note) The EC series uses a built-in controller. For details about the built-in controller, refer to page 32.
The "PSA-200" DC motor power unit is required for any EleCylinder that uses 230V servo motors. Refer to page 34 for details about the PSA-200.

EC-S13

Large Slider Type

±10μm Standard

Battery-less Absolute

Motor Unit Coupled

Straight Motor

Body Width
130 mm

230V
AC Servo Motor

Model items

EC - **S13** [] - [] - [] - [] - []

Series	Type	Lead	Stroke	Power/IO cable length	Motor power cable length	Option
		S 30mm	100 100mm	Please see cable length table below.	0 No cable	Please see options table below.
		H 20mm	1100 1100mm		1 1m	
		M 10mm	1100 1100mm		2 2m	
		L 5mm	(50-mm increments)		10 10m	

RoHS

Horizontal

Vertical

Side

Ceiling



POINT
Selection
Notes

- (1) As the stroke length increases, the speed decreases due to excessive vibration of the ballscrew. Please confirm the maximum speed at the desired stroke using the "stroke and max. speed" table.
- (2) The payload of "main specification" shows the maximum value. For details, refer to the "table of payload by speed/acceleration."
- (3) For these actuators to operate the DC motor drive power unit "PSA-200" is necessary. One "PSA-200" can supply power up to 6 axes. For details, refer to page 34.
- (4) Depending on the operation condition (payload, acceleration/deceleration), rough guide for available duty ratio varies. For details, refer to page 30.
- (5) Pay close attention to the installation orientation. Refer to page 4 for details.
- (6) Rough guide for overhang load length is 600mm or less (960mm or less for double slider specification) in Ma/Mb/Mc directions.

Power / I/O Cable Length

Cable code	Cable length	User wiring specification	RCON-EC connection specification (*2)
		Discrete wiring	With connectors at both ends
0	No cable	Terminal block supplied (*1)	CB-REC-PWBIO□□□-RB supplied
1~3	1~3m	CB-EC-PWBIO□□□-RB supplied	
4~5	4~5m		
6~7	6~7m		
8~10	8~10m		

(*1) When „No cable“ is selected only terminal block connector is supplied. For details, refer to page 33.
 (*2) This applies when RCON-EC connection specification (ACR) is selected as an option.
 (Note) These are robot cables.

Motor Power Cable Length

Cable code	Cable length	User wiring / RCON-EC connection specific.
0	No cable	CB-EC-PW□□□-RB supplied
1~3	1~3m	
4~5	4~5m	
6~10	6~10m	

(Note) These are robot cables.

Option

Name	Option code	Reference page
RCON-EC connection specification (Note 1)	ACR	29
Brake	B	29
Specified grease application specification	GS	29
Reversed-home specification	NM	29
PNP specification (Note 1)	PN	29
Double power circuit specification (Note 1)	TMD2	29
Double slider specification (Note 2)	W	29
Wireless communication specification	WL	29
Wireless axis operation compatible specification	WL2	29

(Note 1) When RCON-EC connection specification (ACR) is selected, PNP specification (PN) or double power circuit specification (TMD2) cannot be selected.
 (Note 2) The allowable payload, dimensions, and body mass will be different for the double slider specification.

Main Specifications

Item		Details				
Lead	Ball screw lead (mm)	30	20	10	5	
Horizontal	Payload	Maximum payload (kg) (*1)	27	40.5	81	90
		Maximum speed (mm/s)	1500	1000	500	250
	Speed/acceleration/deceleration	Rated acceleration/deceleration (G)	0.3	0.3	0.3	0.3
		Maximum acceleration/deceleration (G)	1	1	0.7	0.5
Vertical	Payload	Maximum payload (kg) (*1)	5.4	9	18	30.6
		Maximum speed (mm/s)	1500	1000	500	250
	Speed/acceleration/deceleration	Rated acceleration/deceleration (G)	0.3	0.3	0.3	0.3
		Maximum acceleration/deceleration (G)	0.7	0.7	0.5	0.3
Thrust	Rated thrust (N)	113.9	170.9	341.8	683.6	
Brake	Brake specification	Non-excited operation electromagnetic brake				
	Brake retaining force (kgf)	5.4	9	18	30.6	
Stroke	Minimum stroke (mm)	100	100	100	100	
	Maximum stroke (mm)	1100	1100	1100	1100	
	Stroke pitch (mm)	50	50	50	50	

(*1) The maximum payload decreases when the double slider specification (W) is selected. See the table below.

Slider type moment direction

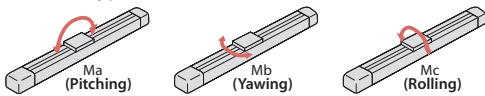

Item	Details
Drive method	Ball screw ø16 mm rolled C10 equivalent
Positioning repeatability	±0.01mm
Lost motion	—
Base	Dedicated extruded aluminum (A6063SS-T6 equivalent), black alumite treatment
Linear guide	Linear motion endlessly circulating type
Static allowable moment (*2)	Ma: 518 N·m [3530 N·m]
	Mb: 518 N·m [3530 N·m]
	Mc: 1210 N·m [2420 N·m]
Dynamic allowable moment (*2) (*3)	Ma: 107 N·m [592 N·m]
	Mb: 107 N·m [592 N·m]
	Mc: 250 N·m [406 N·m]
Ambient operating air temperature, humidity	0 to 40°C, 85%RH max. (no condensation)
Protection class	—
Vibration resistance/shock resistance	4.9m/s ²
Overseas standard compliance	CE Marking, RoHS Directive
Motor type	AC servo motor (230 V)
Rated motor capacity	200W
Encoder type	Battery-less absolute
Encoder pulse count	16384 pulse/rev

(*2) Values in the brackets [] are for the double slider specification (W).

(*3) Based on the assumption of a standard rated life of 10000 km. The traveling life varies depending on the operating conditions and installation conditions.

Table of Payload by Speed/Acceleration

Payload shown in units of kg.

Lead 30

Orientation	Horizontal			Vertical			
	Acceleration (G)						
Speed (mm/s)	0.3	0.5	0.7	1.0	0.3	0.5	0.7
0	27	21.6	15.3	10.8	5.4	5	4.1
1500	27	21.6	15.3	10.8	5.4	5	4.1

Lead 20

Orientation	Horizontal			Vertical			
	Acceleration (G)						
Speed (mm/s)	0.3	0.5	0.7	1.0	0.3	0.5	0.7
0	40.5	31.5	20.7	13.5	9	7.7	6.3
1000	40.5	31.5	20.7	13.5	9	7.7	6.3

Lead 10

Orientation	Horizontal			Vertical		
	Acceleration (G)					
Speed (mm/s)	0.3	0.5	0.7	0.3	0.5	0.5
0	81	59.4	36	18	15.3	
500	81	59.4	36	18	15.3	

Lead 5

Orientation	Horizontal			Vertical		
	Acceleration (G)					
Speed (mm/s)	0.3	0.5	0.3	0.5	0.3	0.3
0	90	72		30.6		
250	90	72		30.6		

Table of Payload by Speed/Acceleration (double slider specification)

Payload shown in units of kg. Blank cells mean the actuator cannot be operated under those conditions.

Lead 30

Orientation	Horizontal						Vertical						
	Acceleration (G)												
Speed (mm/s)	0.3	0.5	0.7	1.0	0.3	0.5	0.7	0.3	0.5	0.7	0.3	0.5	0.7
0	22	16.6	10.3	5.8									
1500	22	16.6	10.3	5.8									

Lead 20

Orientation	Horizontal						Vertical						
	Acceleration (G)												
Speed (mm/s)	0.3	0.5	0.7	1.0	0.3	0.5	0.7	0.3	0.5	0.7	0.3	0.5	0.7
0	35.5	26.5	15.7	8.5	4	2.7							
1000	35.5	26.5	15.7	8.5	4	2.7							

Lead 10

Orientation	Horizontal					Vertical				
	Acceleration (G)									
Speed (mm/s)	0.3	0.5	0.7	0.3	0.5	0.3	0.5	0.3	0.5	0.3
0	76	54.4	31	13	10.3					
500	76	54.4	31	13	10.3					

Lead 5

Orientation	Horizontal			Vertical		
	Acceleration (G)					
Speed (mm/s)	0.3	0.5	0.3	0.5	0.3	0.3
0	85	67		25.6		
250	85	67		25.6		

Stroke and maximum speed

Stroke	100 ~ 650 (50-mm increment)	700 (mm)	750 (mm)	800 (mm)	850 (mm)	900 (mm)	950 (mm)	1000 (mm)	1050 (mm)	1100 (mm)
30	1500	1458	1297	1161	1045	946	860	785	720	663
20	1000	972	865	774	697	630	573	524	480	442
10	500	486	432	387	348	315	287	262	240	221
5	250	243	216	193	174	158	143	131	120	110

(Unit: mm/s)

Dimensions

(Note) The slider moves to the M.E. during home return. Pay attention to prevent contact between the slider and surrounding parts.

CAD drawings can be downloaded from our website.
www.elecylinder.de



ST: Stroke
M.E.: Mechanical end
S.E.: Stroke end

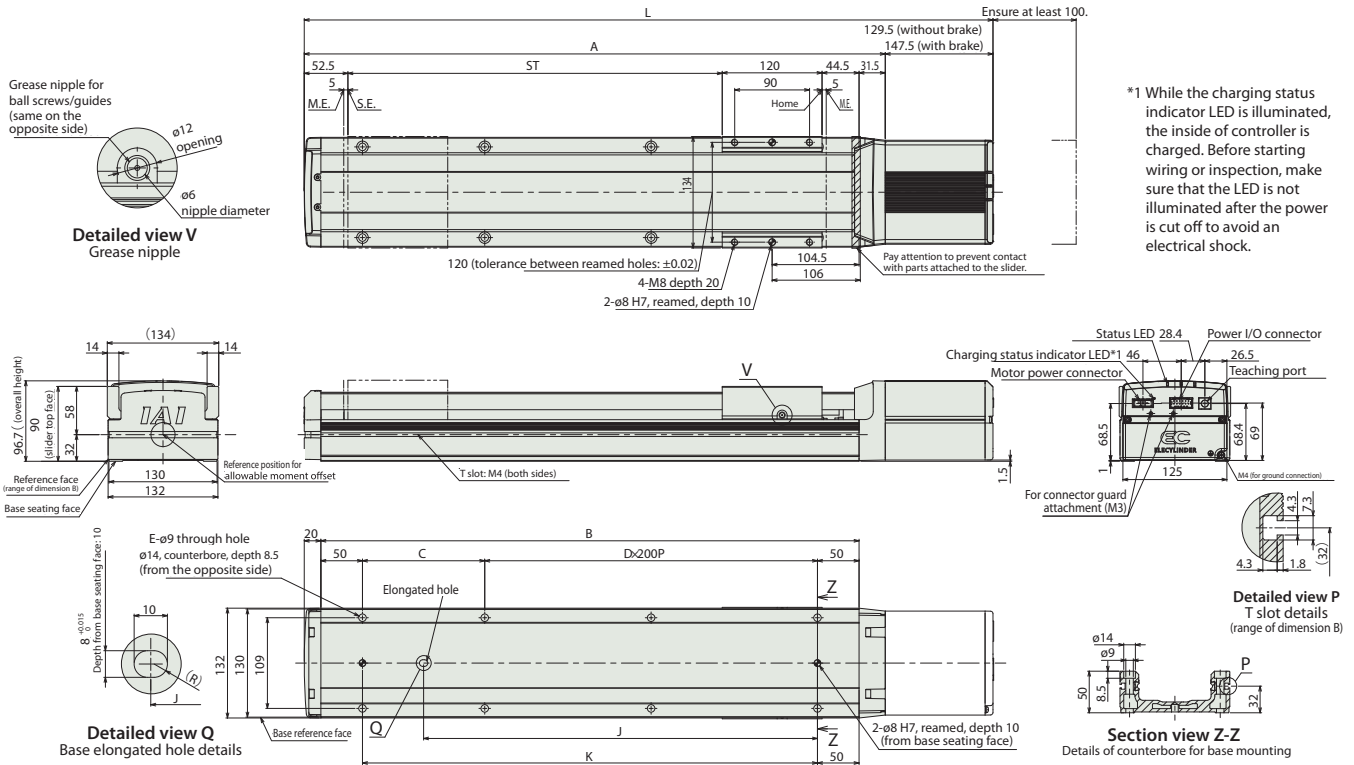

*1 While the charging status indicator LED is illuminated, the inside of controller is charged. Before starting wiring or inspection, make sure that the LED is not illuminated after the power is cut off to avoid an electrical shock.

Dimension by stroke

Stroke	100	150	200	250	300	350	400	450	500	550	600	650	700	750	800	850	900	950	1000	1050	1100	
L	Without brake	478	528	578	628	678	728	778	828	878	928	978	1028	1078	1128	1178	1228	1278	1328	1378	1428	1478
	With brake	496	546	596	646	696	746	796	846	896	946	996	1046	1096	1146	1196	1246	1296	1346	1396	1446	1496
A	348.5	398.5	448.5	498.5	548.5	598.5	648.5	698.5	748.5	798.5	848.5	898.5	948.5	998.5	1048.5	1098.5	1148.5	1198.5	1248.5	1298.5	1348.5	1398.5
B	297	347	397	447	497	547	597	647	697	747	797	847	897	947	997	1047	1097	1147	1197	1247	1297	1347
C	197	247	297	347	397	447	497	547	597	647	697	747	797	847	897	947	997	1047	1097	1147	1197	1247
D	0	0	0	1	1	1	1	2	2	2	2	3	3	3	3	4	4	4	4	5	5	5
E	4	4	4	6	6	6	6	8	8	8	8	10	10	10	10	12	12	12	12	14	14	14
J	98.5	123.5	148.5	173.5	198.5	223.5	248.5	273.5	298.5	323.5	348.5	373.5	398.5	423.5	448.5	473.5	498.5	523.5	548.5	573.5	598.5	623.5
K	197	247	297	347	397	447	497	547	597	647	697	747	797	847	897	947	997	1047	1097	1147	1197	1247

Weight by stroke

Stroke	100	150	200	250	300	350	400	450	500	550	600	650	700	750	800	850	900	950	1000	1050	1100	
Weight (kg)	Without brake	7.3	7.8	8.3	8.7	9.2	9.7	10.2	10.7	11.1	11.6	12.1	12.6	13.1	13.6	14.0	14.5	15.0	15.5	16.0	16.4	16.9
	With brake	7.8	8.3	8.8	9.3	9.8	10.3	10.7	11.2	11.7	12.2	12.7	13.1	13.6	14.1	14.6	15.1	15.5	16.0	16.5	17.0	17.5

Dimensions (double slider specification)

(Note) The slider moves to the M.E. during home return. Pay attention to prevent contact between the slider and surrounding parts.

CAD drawings can be downloaded from our website.
www.elecylinder.de



ST: Stroke
M.E.: Mechanical end
S.E.: Stroke end

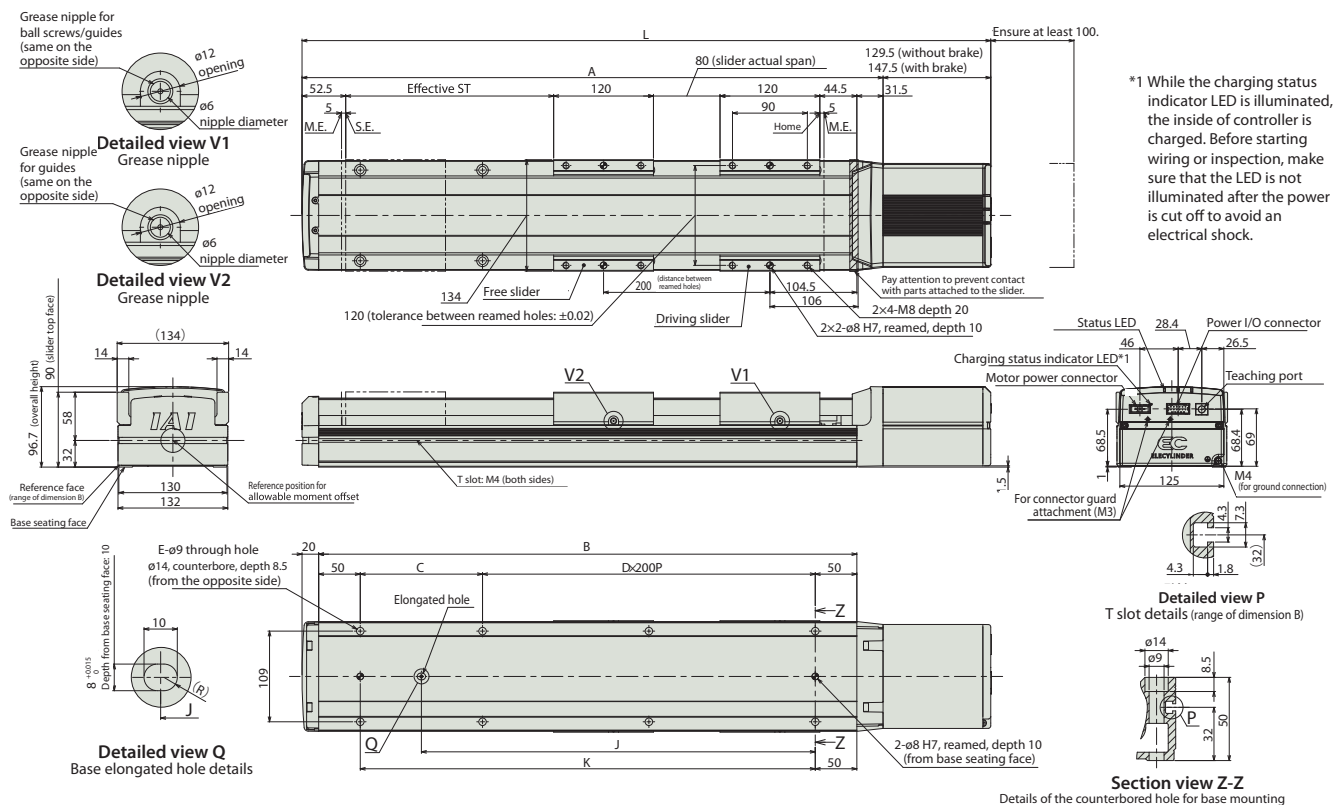

Dimension by stroke

Nominal stroke	300	350	400	450	500	550	600	650	700	750	800	850	900	950	1000	1050	1100	
Effective stroke	100	150	200	250	300	350	400	450	500	550	600	650	700	750	800	850	900	
L	Without brake	678	728	778	828	878	928	978	1028	1078	1128	1178	1228	1278	1328	1378	1428	1478
	With brake	696	746	796	846	896	946	996	1046	1096	1146	1196	1246	1296	1346	1396	1446	1496
A	548.5	598.5	648.5	698.5	748.5	798.5	848.5	898.5	948.5	998.5	1048.5	1098.5	1148.5	1198.5	1248.5	1298.5	1348.5	
B	497	547	597	647	697	747	797	847	897	947	997	1047	1097	1147	1197	1247	1297	
C	197	247	297	347	397	447	497	547	597	647	697	747	797	847	897	947	997	
D	1	1	1	2	2	2	2	3	3	3	3	4	4	4	4	5	5	
E	6	6	6	8	8	8	8	10	10	10	10	12	12	12	12	14	14	
J	298.5	323.5	348.5	373.5	398.5	423.5	448.5	473.5	498.5	523.5	548.5	573.5	598.5	623.5	648.5	673.5	698.5	
K	397	447	497	547	597	647	697	747	797	847	897	947	997	1047	1097	1147	1197	

(Note) Nominal stroke: stroke specified in the model code.
Effective stroke: actual operable stroke

Weight by stroke

Nominal stroke	300	350	400	450	500	550	600	650	700	750	800	850	900	950	1000	1050	1100	
Effective stroke	100	150	200	250	300	350	400	450	500	550	600	650	700	750	800	850	900	
Weight (kg)	Without brake	10.9	11.4	11.9	12.4	12.8	13.3	13.8	14.3	14.8	15.3	15.7	16.2	16.7	17.2	17.7	18.1	18.6
	With brake	11.5	12.0	12.4	12.9	13.4	13.9	14.4	14.8	15.3	15.8	16.3	16.8	17.2	17.7	18.2	18.7	19.2

(Note) Weight that is added by 1.7kg of the free slider weight to the single slider specification.

Compatible controller

(Note) The EC series uses a built-in controller. For details about the built-in controller, refer to page 32.
The "PSA-200" DC motor power unit is required for any EleCylinder that uses 230V servo motors. Refer to page 34 for details about the PSA-200.

EC-S13X (with an intermediate support)

Large Slider Type

Intermediate SUPPORT

±10μm Standard

Battery-less Absolute

Motor Unit Coupled

Straight Motor

Body Width 130 mm

230v AC Servo Motor

Model items

EC	S13X					
Series	Type	Lead	Stroke	Power/I/O cable length	Motor power cable length	Option
		S 30mm H 20mm M 10mm L 5mm	800 ± 800mm 2000 ± 2000mm (50-mm increments)	Please see cable length table below.	0 No cable 1 1m ± ± 10 10m	Please see options table below.

RoHS

Horizontal

Vertical

Side

Ceiling



- (1) As the stroke length increases, the speed decreases due to excessive vibration of the ballscrew. Please confirm the maximum speed at the desired stroke using the "stroke and max. speed" table.
 (2) The payload of "main specification" shows the maximum value. For details, refer to the "table of payload by speed/acceleration."
 (3) For these actuators to operate the DC motor drive power unit "PSA-200" is necessary. One "PSA-200" can supply power up to 6 axes. For details, refer to page 34.
 (4) Depending on the operation condition (payload, acceleration/deceleration), rough guide for available duty ratio varies. For details, refer to page 30.
 (5) Pay close attention to the installation orientation. Refer to page 4 for details.
 (6) Rough guide for overhang load length is 600mm or less (825mm or less for double slider specification) in Ma/Mb/Mc directions.
 (7) For the intermediate support type, a collision sound occurs during operation due to the structure of support mechanism.

Power / I/O Cable Length

Cable code	Cable length	User wiring specification	RCON-EC connection specification (*2)
		Discrete wiring	With connectors at both ends
0	No cable	Terminal block supplied (*1)	CB-REC-PWBIO□□□-RB supplied
1 ~ 3	1 ~ 3m	CB-EC-PWBIO□□□-RB supplied	
4 ~ 5	4 ~ 5m		
6 ~ 7	6 ~ 7m		
8 ~ 10	8 ~ 10m		

(*1) When „No cable“ is selected only terminal block connector is supplied. For details, refer to page 33.
 (*2) This applies when RCON-EC connection specification (ACR) is selected as an option.
 (Note) These are robot cables.

Motor Power Cable Length

Cable code	Cable length	User wiring / RCON-EC connection specific.
0	No cable	CB-EC-PW□□□-RB supplied
1 ~ 3	1 ~ 3m	
4 ~ 5	4 ~ 5m	
6 ~ 10	6 ~ 10m	

(Note) These are robot cables.

Option

Name	Option code	Reference page
RCON-EC connection specification (Note 1)	ACR	29
Brake	B	29
Specified grease application specification	GS	29
Reversed-home specification	NM	29
PNP specification (Note 1)	PN	29
Double power circuit specification (Note 1)	TMD2	29
Double slider specification (Note 2)	W	29
Wireless communication specification	WL	29
Wireless axis operation compatible specification	WL2	29

(Note 1) When RCON-EC connection specification (ACR) is selected, PNP specification (PN) or double power circuit specification (TMD2) cannot be selected.
 (Note 2) The allowable payload, dimensions, and body mass will be different for the double slider specification.

Main Specifications

Item		Details				
Lead	Ball screw lead (mm)	30	20	10	5	
Horizontal	Payload	Maximum payload (kg) (*1)	27	40.5	81	90
		Maximum speed (mm/s)	1500	1000	500	250
	Speed/acceleration/deceleration	Rated acceleration/deceleration (G)	0.3	0.3	0.3	0.3
		Maximum acceleration/deceleration (G)	1	1	0.7	0.5
Vertical	Payload	Maximum payload (kg) (*1)	5.4	9	18	30.6
		Maximum speed (mm/s)	1500	1000	500	250
	Speed/acceleration/deceleration	Rated acceleration/deceleration (G)	0.3	0.3	0.3	0.3
		Maximum acceleration/deceleration (G)	0.7	0.7	0.5	0.3
Thrust	Rated thrust (N)	113.9	170.9	341.8	683.6	
Brake	Brake specification	Non-excited operation electromagnetic brake				
	Brake retaining force (kgf)	5.4	9	18	30.6	
Stroke	Minimum stroke (mm)	800	800	800	800	
	Maximum stroke (mm)	2000	2000	2000	2000	
	Stroke pitch (mm)	50	50	50	50	

(*1) The maximum payload decreases when the double slider specification (W) is selected. See the table below.

Item	Details
Drive method	Ball screw ø16 mm rolled C10 equivalent
Positioning repeatability	±0.01mm
Lost motion	—
Base	Dedicated extruded aluminum (A6063SS-T6 equivalent), black alumite treatment
Linear guide	Linear motion endlessly circulating type
Static allowable moment (*2)	Ma: 518 N·m [2620 N·m]
	Mb: 518 N·m [2620 N·m]
	Mc: 1210 N·m [2420 N·m]
Dynamic allowable moment (*2) (*3)	Ma: 107 N·m [439 N·m]
	Mb: 107 N·m [439 N·m]
	Mc: 250 N·m [406 N·m]
Ambient operating air temperature, humidity	0 to 40°C, 85%RH max. (no condensation)
Protection class	—
Vibration resistance/shock resistance	4.9m/s ²
Overseas standard compliance	CE Marking, RoHS Directive
Motor type	AC servo motor (230 V)
Rated motor capacity	200W
Encoder type	Battery-less absolute
Encoder pulse count	16384 pulse/rev

(*2) Values in the brackets [] are for the double slider specification (W).

(*3) Based on the assumption of a standard rated life of 10000 km. The traveling life varies depending on the operating conditions and installation conditions.

Slider type moment direction

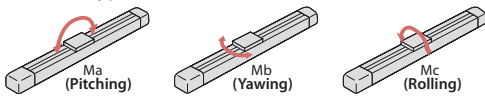

Table of Payload by Speed/Acceleration

Payload shown in units of kg.

Lead 30

Orientation	Horizontal				Vertical		
	Acceleration (G)						
Speed (mm/s)	0.3	0.5	0.7	1.0	0.3	0.5	0.7
0	27	21.6	15.3	10.8	5.4	5	4.1
1500	27	21.6	15.3	10.8	5.4	5	4.1

Lead 20

Orientation	Horizontal				Vertical		
	Acceleration (G)						
Speed (mm/s)	0.3	0.5	0.7	1.0	0.3	0.5	0.7
0	40.5	31.5	20.7	13.5	9	7.7	6.3
1000	40.5	31.5	20.7	13.5	9	7.7	6.3

Lead 10

Orientation	Horizontal				Vertical	
	Acceleration (G)					
Speed (mm/s)	0.3	0.5	0.7	0.3	0.5	
0	81	59.4	36	18	15.3	
500	81	59.4	36	18	15.3	

Lead 5

Orientation	Horizontal			Vertical	
	Acceleration (G)				
Speed (mm/s)	0.3	0.5	0.3	0.5	
0	90	72	30.6		
250	90	72	30.6		

Table of Payload by Speed/Acceleration (double slider specification)

Payload shown in units of kg. Blank cells mean the actuator cannot be operated under those conditions.

Lead 30

Orientation	Horizontal						Vertical		
	Acceleration (G)								
Speed (mm/s)	0.3	0.5	0.7	1.0	0.3	0.5	0.7		
0	22	16.6	10.3	5.8					
1500	22	16.6	10.3	5.8					

Lead 20

Orientation	Horizontal						Vertical		
	Acceleration (G)								
Speed (mm/s)	0.3	0.5	0.7	1.0	0.3	0.5	0.7		
0	35.5	26.5	15.7	8.5	4	2.7			
1000	35.5	26.5	15.7	8.5	4	2.7			

Lead 10

Orientation	Horizontal					Vertical	
	Acceleration (G)						
Speed (mm/s)	0.3	0.5	0.7	0.3	0.5		
0	76	54.4	31	13	10.3		
500	76	54.4	31	13	10.3		

Lead 5

Orientation	Horizontal			Vertical	
	Acceleration (G)				
Speed (mm/s)	0.3	0.5	0.3	0.5	
0	85	67	25.6		
250	85	67	25.6		

Stroke and maximum speed

Stroke / Lead (mm)	800~1500 (50-mm increment)	1550 (mm)	1600 (mm)	1650 (mm)	1700 (mm)	1750 (mm)	1800 (mm)	1850 (mm)	1900 (mm)	1950 (mm)	2000 (mm)
30	1500	1450	1380	1314	1254	1197	1144	1095	1049	1005	964
20	1000	966	920	876	836	798	763	730	699	670	643
10	500	483	460	438	418	399	381	365	350	335	321
5	250	242	230	219	209	200	191	182	175	168	161

(Unit: mm/s)

Dimensions

(Note) The slider moves to the M.E. during home return. Pay attention to prevent contact between the slider and surrounding parts.

CAD drawings can be downloaded from our website.
www.elecylinder.de



ST: Stroke
M.E.: Mechanical end
S.E.: Stroke end

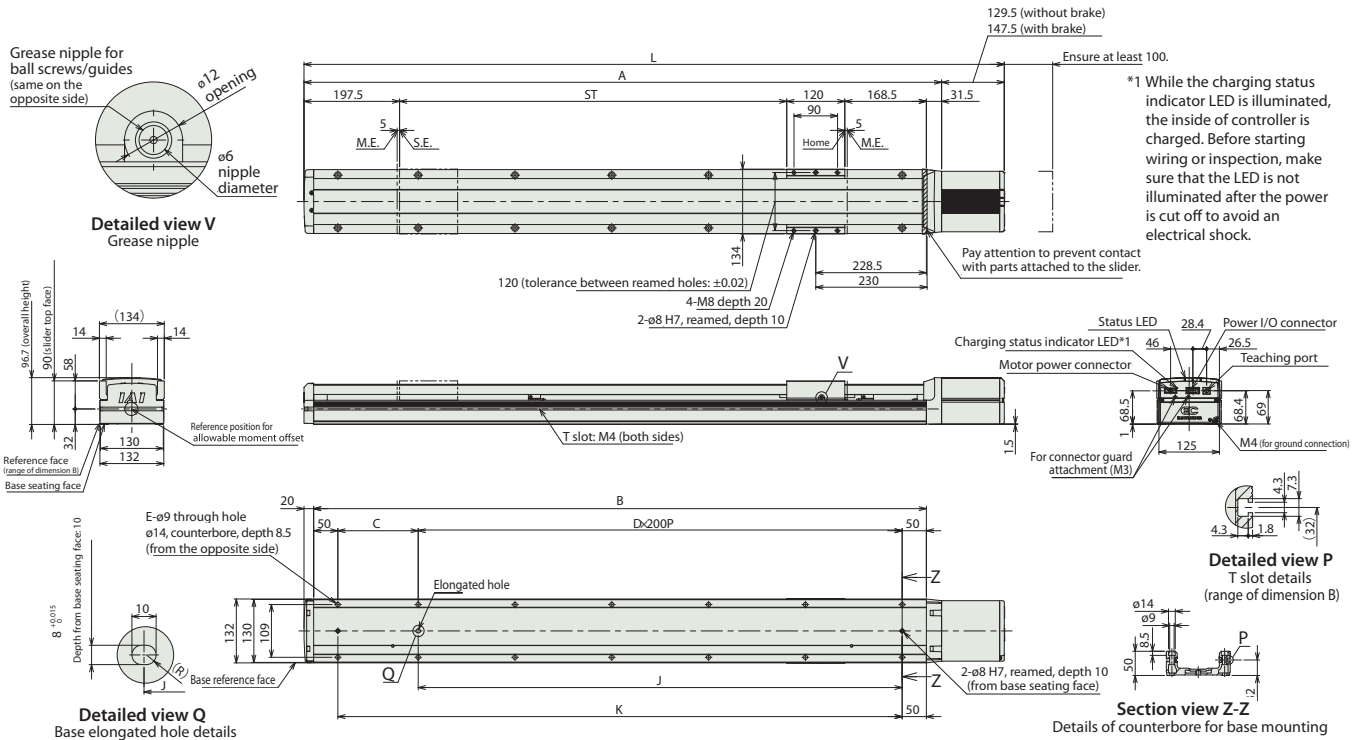

Dimension by stroke

Stroke	800	850	900	950	1000	1050	1100	1150	1200	1250	1300	1350	1400	1450	1500	1550	1600	1650	1700	1750	1800	1850	1900	1950	2000	
L	Without brake	1447	1497	1547	1597	1647	1697	1747	1797	1847	1897	1947	1997	2047	2097	2147	2197	2247	2297	2347	2397	2447	2497	2547	2597	2647
	With brake	1465	1515	1565	1615	1665	1715	1765	1815	1865	1915	1965	2015	2065	2115	2165	2215	2265	2315	2365	2415	2465	2515	2565	2615	2665
A	1317.5	1367.5	1417.5	1467.5	1517.5	1567.5	1617.5	1667.5	1717.5	1767.5	1817.5	1867.5	1917.5	1967.5	2017.5	2067.5	2117.5	2167.5	2217.5	2267.5	2317.5	2367.5	2417.5	2467.5	2517.5	2567.5
B	1266	1316	1366	1416	1466	1516	1566	1616	1666	1716	1766	1816	1866	1916	1966	2016	2066	2116	2166	2216	2266	2316	2366	2416	2466	2516
C	166	216	266	316	366	416	466	516	566	616	666	716	766	816	866	916	966	1016	1066	1116	1166	1216	1266	1316	1366	1416
D	5	5	5	5	6	6	6	6	7	7	7	7	8	8	8	8	9	9	9	9	10	10	10	10	10	11
E	14	14	14	14	16	16	16	16	18	18	18	18	20	20	20	20	22	22	22	22	24	24	24	24	24	26
J	1000	1000	100	1000	1200	1200	1200	1200	1400	1400	1400	1400	1600	1600	1600	1600	1800	1800	1800	1800	2000	2000	2000	2000	2000	2200
K	1166	1216	1266	1316	1366	1416	1466	1516	1566	1616	1666	1716	1766	1816	1866	1916	1966	2016	2066	2116	2166	2216	2266	2316	2366	2416

Weight by stroke

Stroke	800	850	900	950	1000	1050	1100	1150	1200	1250	1300	1350	1400	1450	1500	1550	1600	1650	1700	1750	1800	1850	1900	1950	2000	
Weight (kg)	Without brake	17.5	18.0	18.5	19.0	19.5	20.6	21.1	21.6	22.1	22.6	23.1	23.6	24.1	24.6	25.1	25.6	26.1	26.6	27.1	27.6	28.1	28.6	29.1	29.6	30.1
	With brake	18.1	18.6	19.1	19.5	20.0	21.2	21.7	22.2	22.7	23.2	23.7	24.2	24.7	25.2	25.7	26.2	26.7	27.2	27.7	28.2	28.7	29.2	29.7	30.2	30.7

Dimensions (double slider specification)

(Note) The slider moves to the M.E. during home return. Pay attention to prevent contact between the slider and surrounding parts.

CAD drawings can be downloaded from our website.
www.elecylinder.de



ST: Stroke
M.E.: Mechanical end
S.E.: Stroke end

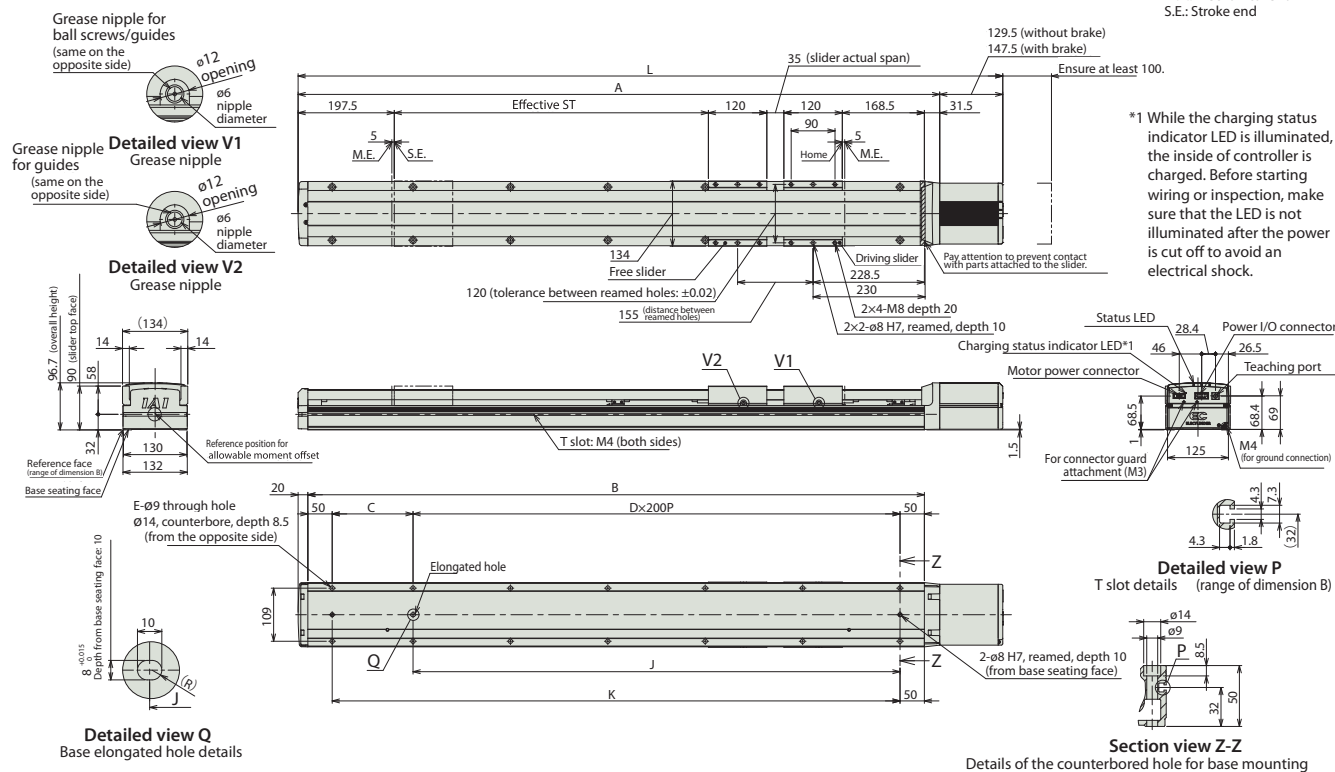

Dimension by stroke

Nominal stroke	800	850	900	950	1000	1050	1100	1150	1200	1250	1300	1350	1400	1450	1500	1550	1600	1650	1700	1750	1800	1850	1900	1950	2000	
Effective stroke	645	695	745	795	845	895	945	995	1045	1095	1145	1195	1245	1295	1345	1395	1445	1495	1545	1595	1645	1695	1745	1795	1845	
L	Without brake	1447	1497	1547	1597	1647	1697	1747	1797	1847	1897	1947	1997	2047	2097	2147	2197	2247	2297	2347	2397	2447	2497	2547	2597	2647
	With brake	1465	1515	1565	1615	1665	1715	1765	1815	1865	1915	1965	2015	2065	2115	2165	2215	2265	2315	2365	2415	2465	2515	2565	2615	2665
A	1317.5	1367.5	1417.5	1467.5	1517.5	1567.5	1617.5	1667.5	1717.5	1767.5	1817.5	1867.5	1917.5	1967.5	2017.5	2067.5	2117.5	2167.5	2217.5	2267.5	2317.5	2367.5	2417.5	2467.5	2517.5	
B	1266	1316	1366	1416	1466	1516	1566	1616	1666	1716	1766	1816	1866	1916	1966	2016	2066	2116	2166	2216	2266	2316	2366	2416	2466	
C	166	216	266	316	366	416	466	516	566	616	666	716	766	816	866	916	966	1016	1066	1116	1166	1216	1266	1316	1366	
D	5	5	5	5	6	6	6	6	7	7	7	7	8	8	8	8	9	9	9	9	10	10	10	10	11	
E	14	14	14	14	16	16	16	16	18	18	18	18	20	20	20	20	22	22	22	22	24	24	24	24	26	
J	1000	1000	1000	1000	1200	1200	1200	1200	1400	1400	1400	1400	1600	1600	1600	1600	1800	1800	1800	1800	2000	2000	2000	2000	2200	
K	1166	1216	1266	1316	1366	1416	1466	1516	1566	1616	1666	1716	1766	1816	1866	1916	1966	2016	2066	2116	2166	2216	2266	2316	2366	

(Note) Nominal stroke: stroke specified in the model code.
Effective stroke: actual operable stroke

Weight by stroke

Nominal stroke	800	850	900	950	1000	1050	1100	1150	1200	1250	1300	1350	1400	1450	1500	1550	1600	1650	1700	1750	1800	1850	1900	1950	2000	
Effective stroke	645	695	745	795	845	895	945	995	1045	1095	1145	1195	1245	1295	1345	1395	1445	1495	1545	1595	1645	1695	1745	1795	1845	
Weight (kg)	Without brake	19.2	19.7	20.2	20.7	21.2	22.3	22.8	23.3	23.8	24.3	24.8	25.3	25.8	26.3	26.8	27.3	27.8	28.3	28.8	29.3	29.8	30.3	30.8	31.3	31.8
	With brake	19.8	20.3	20.8	21.2	21.7	22.9	23.4	23.9	24.4	24.9	25.4	25.9	26.4	26.9	27.4	27.9	28.4	28.9	29.4	29.9	30.4	30.9	31.4	31.9	32.4

(Note) The inclusion of the free slider adds 1.7kg to the actuator weight compared to the single slider specification.

Compatible controller

(Note) The EC series uses a built-in controller. For details about the built-in controller, refer to page 32.
The "PSA-200" DC motor power unit is required for any EleCylinder that uses 230V servo motors. Refer to page 34 for details about the PSA-200.

EC-S15

Large Slider Type

±10μm Standard

Battery-less Absolute

Motor Unit Coupled

Straight Motor

Body Width
160 mm

230V
AC Servo Motor

Model items

EC - S15 [] - [] - [] - [] - []

Series	Type	Lead	Stroke	Power/I/O cable length	Motor power cable length	Option
		H 40mm M 20mm L 10mm	100 100mm 1300 1300mm (50-mm increments)	Please see cable length table below.	0 No cable 1 1m 2 2m 10 10m	Please see options table below.

RoHS

Horizontal

Vertical

Side

Ceiling



- POINT
Selection
Notes

- (1) As the stroke length increases, the speed decreases due to excessive vibration of the ballscrew. Please confirm the maximum speed at the desired stroke using the "stroke and max. speed" table.
 - (2) The payload of "main specification" shows the maximum value. For details, refer to the "table of payload by speed/acceleration."
 - (3) For these actuators to operate the DC motor drive power unit "PSA-200" is necessary. One "PSA-200" can supply power up to 6 axes. For details, refer to page 34.
 - (4) Depending on the operation condition (payload, acceleration/deceleration), rough guide for available duty ratio varies. For details, refer to page 30.
 - (5) Pay close attention to the installation orientation. Refer to page 4 for details.
 - (6) Rough guide for overhang load length is 750mm or less (1050mm or less for double slider specification) in Ma/Mb/Mc directions.

Power / I/O Cable Length

Cable code	Cable length	User wiring specification	RCON-EC connection specification (*2)
		Discrete wiring	With connectors at both ends
0	No cable	Terminal block supplied (*1)	CB-REC-PWBIO□□□-RB supplied
1 ~ 3	1 ~ 3m	CB-EC-PWBIO□□□-RB supplied	
4 ~ 5	4 ~ 5m		
6 ~ 7	6 ~ 7m		
8 ~ 10	8 ~ 10m		

(*1) When „No cable“ is selected only terminal block connector is supplied. For details, refer to page 33.
 (*2) This applies when RCON-EC connection specification (ACR) is selected as an option.
 (Note) These are robot cables.

Motor Power Cable Length

Cable code	Cable length	User wiring / RCON-EC connection specific.
0	No cable	CB-EC-PW□□□-RB supplied
1 ~ 3	1 ~ 3m	
4 ~ 5	4 ~ 5m	
6 ~ 10	6 ~ 10m	

(Note) These are robot cables.

Option

Name	Option code	Reference page
RCON-EC connection specification (Note 1)	ACR	29
Brake	B	29
Specified grease application specification	GS	29
Reversed-home specification	NM	29
PNP specification (Note 1)	PN	29
Double power circuit specification (Note 1)	TMD2	29
Double slider specification (Note 2)	W	29
Wireless communication specification	WL	29
Wireless axis operation compatible specification	WL2	29

(Note 1) When RCON-EC connection specification (ACR) is selected, PNP specification (PN) or double power circuit specification (TMD2) cannot be selected.
 (Note 2) The allowable payload, dimensions, and body mass will be different for the double slider specification.

Main Specifications

Item		Details			
Lead	Ball screw lead (mm)	40	20	10	
Horizontal	Payload	Maximum payload (kg) (*1)	36	81	108
		Maximum speed (mm/s)	2000	1000	500
	Speed/acceleration/deceleration	Rated acceleration/deceleration (G)	0.3	0.3	0.3
		Maximum acceleration/deceleration (G)	1	1	0.7
Vertical	Payload	Maximum payload (kg) (*1)	9	18	36
		Maximum speed (mm/s)	2000	1000	500
	Speed/acceleration/deceleration	Rated acceleration/deceleration (G)	0.3	0.3	0.3
		Maximum acceleration/deceleration (G)	0.7	0.7	0.5
Thrust	Rated thrust (N)	169.6	339.1	678.3	
Brake	Brake specification	Non-excited operation electromagnetic brake			
	Brake retaining force (kgf)	9	18	36	
Stroke	Minimum stroke (mm)	100	100	100	
	Maximum stroke (mm)	1300	1300	1300	
	Stroke pitch (mm)	50	50	50	

(*1) The maximum payload decreases when the double slider specification (W) is selected. See the table below.

Item	Details
Drive method	Ball screw ø20 mm rolled C10 equivalent
Positioning repeatability	±0.01mm
Lost motion	—
Base	Dedicated extruded aluminum (A6063S5-T6 equivalent), black alumite treatment
Linear guide	Linear motion endlessly circulating type
Static allowable moment (*2)	Ma: 852 N·m [4460 N·m]
	Mb: 852 N·m [4460 N·m]
	Mc: 2010 N·m [4030 N·m]
Dynamic allowable moment (*2) (*3)	Ma: 162 N·m [691 N·m]
	Mb: 162 N·m [691 N·m]
	Mc: 384 N·m [624 N·m]
Ambient operating air temperature, humidity	0 to 40°C, 85% RH max. (no condensation)
Protection class	—
Vibration resistance/shock resistance	4.9m/s ²
Overseas standard compliance	CE Marking, RoHS Directive
Motor type	AC servo motor (230 V)
Rated motor capacity	400W
Encoder type	Battery-less absolute
Encoder pulse count	16384 pulse/rev

(*2) Values in the brackets [] are for the double slider specification (W).

(*3) Based on the assumption of a standard rated life of 10000 km. The traveling life varies depending on the operating conditions and installation conditions.

Slider type moment direction

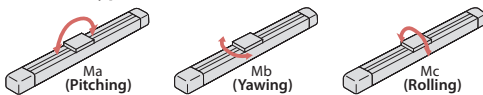

Table of Payload by Speed/Acceleration

Payload shown in units of kg.

Lead 40

Orientation	Horizontal				Vertical		
	Acceleration (G)						
Speed (mm/s)	0.3	0.5	0.7	1.0	0.3	0.5	0.7
0	36	28.8	20.7	15.3	9	7.7	6.3
2000	36	28.8	20.7	15.3	9	7.7	6.3

Lead 20

Orientation	Horizontal				Vertical		
	Acceleration (G)						
Speed (mm/s)	0.3	0.5	0.7	1.0	0.3	0.5	0.7
0	81	63	42.3	27	18	15.3	12.6
1000	81	63	42.3	27	18	15.3	12.6

Lead 10

Orientation	Horizontal			Vertical	
	Acceleration (G)				
Speed (mm/s)	0.3	0.5	0.7	0.3	0.5
0	108	82.8	54	36	30.6
500	108	82.8	54	36	30.6

Table of Payload by Speed/Acceleration (double slider specification)

Payload shown in units of kg. Blank cells mean the actuator cannot be operated under those conditions.

Lead 40

Orientation	Horizontal				Vertical		
	Acceleration (G)						
Speed (mm/s)	0.3	0.5	0.7	1.0	0.3	0.5	0.7
0	31	23.8	15.7	10.3	4	2.7	
2000	31	23.8	15.7	10.3	4	2.7	

Lead 20

Orientation	Horizontal				Vertical		
	Acceleration (G)						
Speed (mm/s)	0.3	0.5	0.7	1.0	0.3	0.5	0.7
0	76	58	37.3	22	13	10.3	7.6
1000	76	58	37.3	22	13	10.3	7.6

Lead 10

Orientation	Horizontal			Vertical	
	Acceleration (G)				
Speed (mm/s)	0.3	0.5	0.7	0.3	0.5
0	103	77.8	49	31	25.6
500	103	77.8	49	31	25.6

Stroke and maximum speed

Stroke	100~750 (50-mm increment)	800 (mm)	850 (mm)	900 (mm)	950 (mm)	1000 (mm)	1050 (mm)	1100 (mm)	1150 (mm)	1200 (mm)	1250 (mm)	1300 (mm)
Lead (mm)												
40	2000	1922	1736	1575	1436	1315	1208	1114	1030	955	889	829
20	1000	961	868	788	718	657	604	557	515	478	444	414
10	500	481	434	394	359	329	302	278	258	239	222	207

(Unit: mm/s)

Dimensions

(Note) The slider moves to the M.E. during home return. Pay attention to prevent contact between the slider and surrounding parts.

CAD drawings can be downloaded from our website.
www.elecylinder.de



ST: Stroke
M.E.: Mechanical end
S.E.: Stroke end

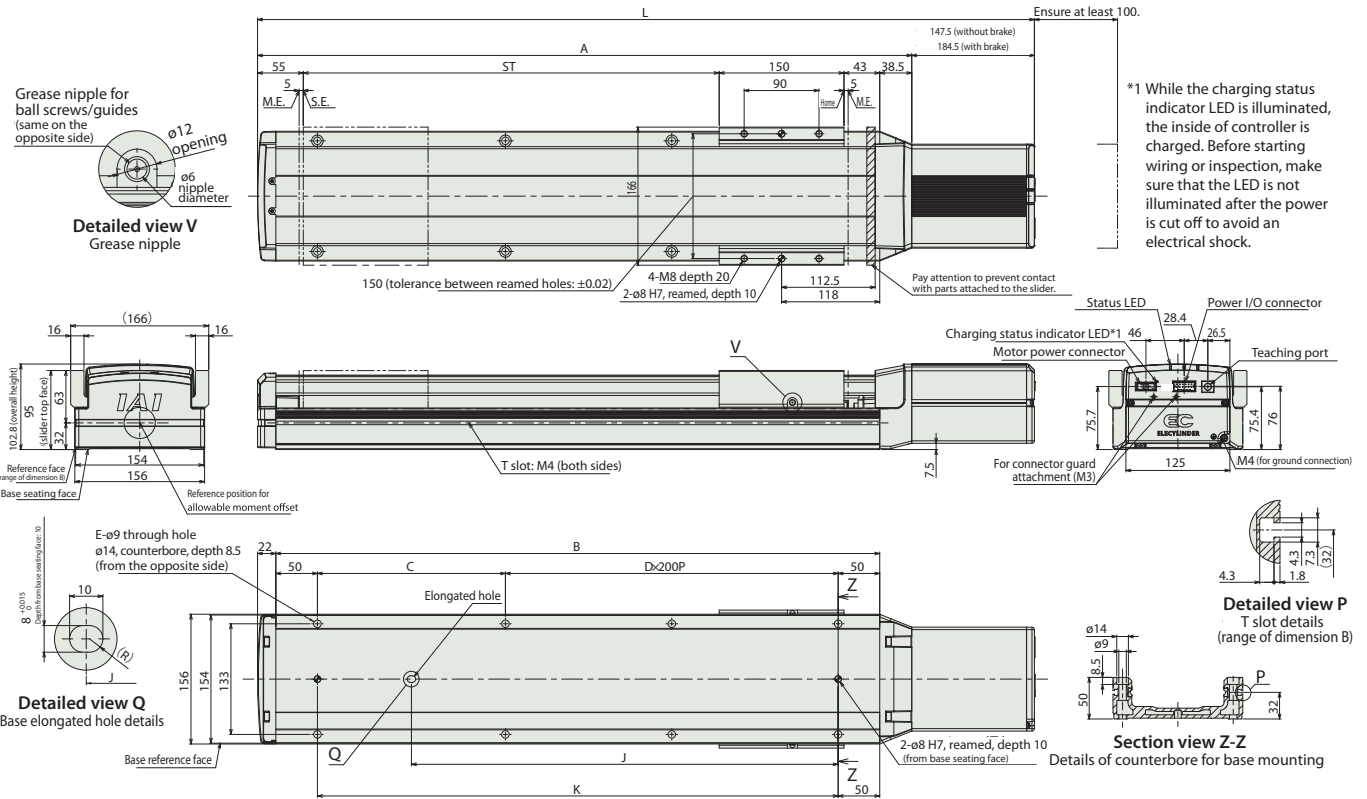

Dimension by stroke

Stroke	100	150	200	250	300	350	400	450	500	550	600	650	700	750	800	850	900	950	1000	1050	1100	1150	1200	1250	1300	
L	Without brake	534	584	634	684	734	784	834	884	934	984	1034	1084	1134	1184	1234	1284	1334	1384	1434	1484	1534	1584	1634	1684	1734
	With brake	571	621	671	721	771	821	871	921	971	1021	1071	1121	1171	1221	1271	1321	1371	1421	1471	1521	1571	1621	1671	1721	1771
A	386.5	436.5	486.5	536.5	586.5	636.5	686.5	736.5	786.5	836.5	886.5	936.5	986.5	1036.5	1086.5	1136.5	1186.5	1236.5	1286.5	1336.5	1386.5	1436.5	1486.5	1536.5	1586.5	1636.5
B	326	376	426	476	526	576	626	676	726	776	826	876	926	976	1026	1076	1126	1176	1226	1276	1326	1376	1426	1476	1526	1576
C	226	276	326	376	426	476	526	576	626	676	726	776	826	876	926	976	1026	1076	1126	1176	1226	1276	1326	1376	1426	1476
D	0	0	1	1	1	1	2	2	2	2	3	3	3	3	4	4	4	4	5	5	5	5	6	6	6	6
E	4	4	6	6	6	6	8	8	8	8	10	10	10	10	12	12	12	12	14	14	14	14	16	16	16	16
J	113	138	263	288	313	338	463	488	513	538	663	688	713	738	863	888	913	938	1063	1088	1113	1138	1263	1288	1313	1338
K	226	276	326	376	426	476	526	576	626	676	726	776	826	876	926	976	1026	1076	1126	1176	1226	1276	1326	1376	1426	1476

Weight by stroke

Stroke	100	150	200	250	300	350	400	450	500	550	600	650	700	750	800	850	900	950	1000	1050	1100	1150	1200	1250	1300	
Weight (kg)	Without brake	9.9	10.5	11.0	11.6	12.2	12.7	13.3	13.8	14.4	14.9	15.5	16.1	16.6	17.2	17.7	18.3	18.8	19.4	20.0	20.5	21.1	21.6	22.2	22.7	23.3
	With brake	10.5	11.1	11.7	12.2	12.8	13.3	13.9	14.4	15.0	15.6	16.1	16.7	17.2	17.8	18.3	18.9	19.5	20.0	20.6	21.1	21.7	22.2	22.8	23.4	23.9

Dimensions (double slider specification)

(Note) The slider moves to the M.E. during home return. Pay attention to prevent contact between the slider and surrounding parts.

CAD drawings can be downloaded from our website.
www.elecylinder.de



ST: Stroke
M.E.: Mechanical end
S.E.: Stroke end

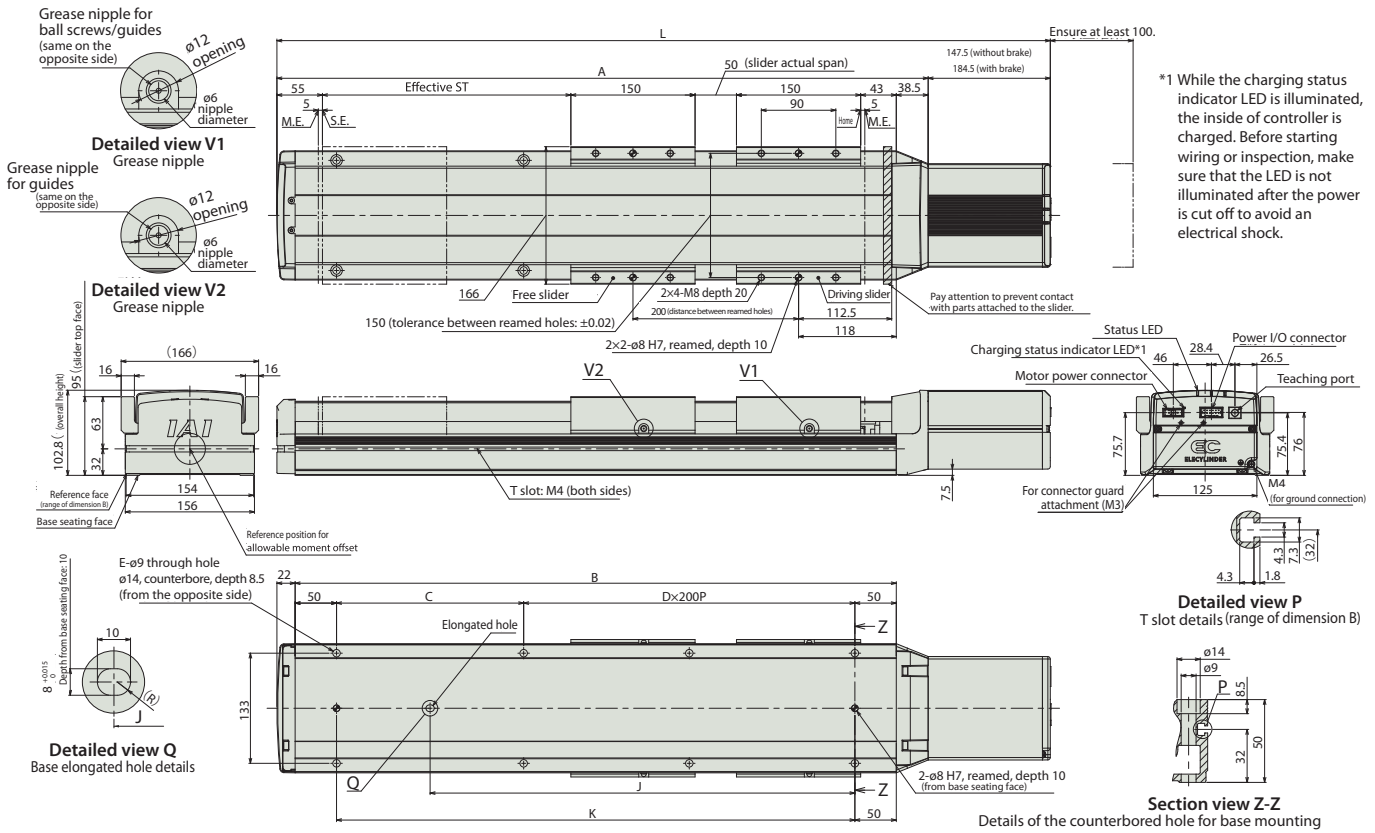

Dimension by stroke

Nominal stroke	300	350	400	450	500	550	600	650	700	750	800	850	900	950	1000	1050	1100	1150	1200	1250	1300	
Effective stroke	100	150	200	250	300	350	400	450	500	550	600	650	700	750	800	850	900	950	1000	1050	1100	
L	Without brake	734	784	834	884	934	984	1034	1084	1134	1184	1234	1284	1334	1384	1434	1484	1534	1584	1634	1684	1734
	With brake	771	821	871	921	971	1021	1071	1121	1171	1221	1271	1321	1371	1421	1471	1521	1571	1621	1671	1721	1771
A	586.5	636.5	686.5	736.5	786.5	836.5	886.5	936.5	986.5	1036.5	1086.5	1136.5	1186.5	1236.5	1286.5	1336.5	1386.5	1436.5	1486.5	1536.5	1586.5	
B	526	576	626	676	726	776	826	876	926	976	1026	1076	1126	1176	1226	1276	1326	1376	1426	1476	1526	
C	226	276	326	376	426	476	526	576	626	676	726	776	826	876	926	976	1026	1076	1126	1176	1226	
D	1	1	2	2	2	2	3	3	3	3	4	4	4	4	5	5	5	5	6	6	6	
E	6	6	8	8	8	8	10	10	10	10	12	12	12	12	14	14	14	14	16	16	16	
J	313	338	463	488	513	538	663	688	713	738	863	888	913	938	1063	1088	1113	1138	1263	1288	1313	
K	426	476	526	576	626	676	726	776	826	876	926	976	1026	1076	1126	1176	1226	1276	1326	1376	1426	

(Note) Nominal stroke: stroke specified in the model code.
Effective stroke: Actual stroke operable

Weight by stroke

Nominal stroke	300	350	400	450	500	550	600	650	700	750	800	850	900	950	1000	1050	1100	1150	1200	1250	1300	
Effective stroke	100	150	200	250	300	350	400	450	500	550	600	650	700	750	800	850	900	950	1000	1050	1100	
Weight (kg)	Without brake	15.0	15.5	16.1	16.6	17.2	17.7	18.3	18.9	19.4	20.0	20.5	21.1	21.6	22.2	22.8	23.3	23.9	24.4	25.0	25.5	26.1
	With brake	15.6	16.1	16.7	17.2	17.8	18.4	18.9	19.5	20.0	20.6	21.1	21.7	22.3	22.8	23.4	23.9	24.5	25.0	25.6	26.2	26.7

(Note) Weight that is added by 1.7kg of the free slider weight to the single slider specification.

Compatible controller

(Note) The EC series uses a built-in controller. For details about the built-in controller, refer to page 32.
The "PSA-200" DC motor power unit is required for any EleCylinder that uses 230V servo motors. Refer to page 34 for details about the PSA-200.

EC-S15X (with an intermediate support)

Large Slider Type

Intermediate SUPPORT

±10μm Standard

Battery-less Absolute

Motor Unit Coupled

Straight Motor

Body Width 160 mm

230V AC Servo Motor

Model items

EC - S15X [] - [] - [] - [] - []

Series	Type	Lead	Stroke	Power/IO cable length	Motor power cable length	Option
		H 40mm M 20mm L 10mm	1000 ± 2500 1000mm ± 2500mm (50-mm increments)	Please see cable length table below.	0 No cable 1 1m ± ± 10 10m	Please see options table below.

RoHS

Horizontal

Vertical

Side

Ceiling



(1) As the stroke length increases, the speed decreases due to excessive vibration of the ballscrew. Please confirm the maximum speed at the desired stroke using the "stroke and max. speed" table.

(2) The payload of "main specification" shows the maximum value. For details, refer to the "table of payload by speed/acceleration."

(3) For these actuators to operate the DC motor drive power unit "PSA-200" is necessary. One "PSA-200" can supply power up to 6 axes. For details, refer to page 34.

(4) Depending on the operation condition (payload, acceleration/deceleration), rough guide for available duty ratio varies. For details, refer to page 30.

(5) Pay close attention to the installation orientation. Refer to page 4 for details.

(6) Rough guide for overhang load length is 750mm or less (1065mm or less for double slider specification) in Ma/Mb/Mc directions.

(7) For the intermediate support type, a collision sound occurs during operation due to the structure of support mechanism.

Power / I/O Cable Length

Cable code	Cable length	User wiring specification	RCON-EC connection specification (*2)
		Discrete wiring	With connectors at both ends
0	No cable	Terminal block supplied (*1)	CB-REC-PWBIO□□□-RB supplied
1 ~ 3	1 ~ 3m	CB-EC-PWBIO□□□-RB supplied	
4 ~ 5	4 ~ 5m		
6 ~ 7	6 ~ 7m		
8 ~ 10	8 ~ 10m		

(*1) When „No cable“ is selected only terminal block connector is supplied. For details, refer to page 33.
 (*2) This applies when RCON-EC connection specification (ACR) is selected as an option.
 (Note) These are robot cables.

Motor Power Cable Length

Cable code	Cable length	User wiring / RCON-EC connection specific.
0	No cable	CB-EC-PW□□□-RB supplied
1 ~ 3	1 ~ 3m	
4 ~ 5	4 ~ 5m	
6 ~ 10	6 ~ 10m	

(Note) These are robot cables.

Option

Name	Option code	Reference page
RCON-EC connection specification (Note 1)	ACR	29
Brake	B	29
Hanging brackets	EB	29
Specified grease application specification	G5	29
Reversed-home specification	NM	29
PNP specification (Note 1)	PN	29
Double power circuit specification (Note 1)	TMD2	29
Double slider specification (Note 2)	W	29
Wireless communication specification	WL	29
Wireless axis operation compatible specification	WL2	29

(Note 1) When RCON-EC connection specification (ACR) is selected, PNP specification (PN) or double power circuit specification (TMD2) cannot be selected.
 (Note 2) The allowable payload, dimensions, and body mass will be different for the double slider specification.

Main Specifications

Item		Details			
Lead	Ball screw lead (mm)	40	20	10	
Horizontal	Payload	Maximum payload (kg) (*1)	36	81	108
		Maximum speed (mm/s)	2000	1000	500
	Speed/acceleration/deceleration	Rated acceleration/deceleration (G)	0.3	0.3	0.3
		Maximum acceleration/deceleration (G)	1	1	0.7
Vertical	Payload	Maximum payload (kg) (*1)	9	18	36
		Maximum speed (mm/s)	2000	1000	500
	Speed/acceleration/deceleration	Rated acceleration/deceleration (G)	0.3	0.3	0.3
		Maximum acceleration/deceleration (G)	0.7	0.7	0.5
Thrust	Rated thrust (N)	169.6	339.1	678.3	
Brake	Brake specification	Non-excited operation electromagnetic brake			
	Brake retaining force (kgf)	9	18	36	
Stroke	Minimum stroke (mm)	1000	1000	1000	
	Maximum stroke (mm)	2500	2500	2500	
	Stroke pitch (mm)	50	50	50	

(*1) The maximum payload decreases when the double slider specification (W) is selected. See the table below.

Item	Details
Drive method	Ball screw ø20 mm rolled C10 equivalent
Positioning repeatability	±0.01mm
Lost motion	—
Base	Dedicated extruded aluminum (A6063S5-T6 equivalent), black alumite treatment
Linear guide	Linear motion endlessly circulating type
Static allowable moment (*2)	Ma: 852 N·m [4590 N·m]
	Mb: 852 N·m [4590 N·m]
	Mc: 2010 N·m [4030 N·m]
Dynamic allowable moment (*2) (*3)	Ma: 162 N·m [711 N·m]
	Mb: 162 N·m [711 N·m]
	Mc: 384 N·m [624 N·m]
Ambient operating air temperature, humidity	0 to 40°C, 85% RH max. (no condensation)
Protection class	—
Vibration resistance/shock resistance	4.9m/s ²
Overseas standard compliance	CE Marking, RoHS Directive
Motor type	AC servo motor (230 V)
Rated motor capacity	400W
Encoder type	Battery-less absolute
Encoder pulse count	16384 pulse/rev

(*2) Values in the brackets [] are for the double slider specification (W).

(*3) Based on the assumption of a standard rated life of 10000 km. The traveling life varies depending on the operating conditions and installation conditions.

Slider type moment direction

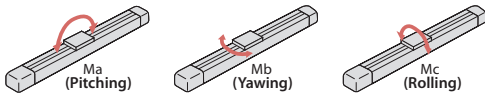

Table of Payload by Speed/Acceleration

Payload shown in units of kg.

Lead 40

Orientation	Horizontal				Vertical		
	Acceleration (G)						
Speed (mm/s)	0.3	0.5	0.7	1.0	0.3	0.5	0.7
0	36	28.8	20.7	15.3	9	7.7	6.3
2000	36	28.8	20.7	15.3	9	7.7	6.3

Lead 20

Orientation	Horizontal				Vertical		
	Acceleration (G)						
Speed (mm/s)	0.3	0.5	0.7	1.0	0.3	0.5	0.7
0	81	63	42.3	27	18	15.3	12.6
1000	81	63	42.3	27	18	15.3	12.6

Lead 10

Orientation	Horizontal			Vertical	
	Acceleration (G)				
Speed (mm/s)	0.3	0.5	0.7	0.3	0.5
0	108	82.8	54	36	30.6
500	108	82.8	54	36	30.6

Table of Payload by Speed/Acceleration (double slider specification)

Payload shown in units of kg. Blank cells mean the actuator cannot be operated under those conditions.

Lead 40

Orientation	Horizontal				Vertical		
	Acceleration (G)						
Speed (mm/s)	0.3	0.5	0.7	1.0	0.3	0.5	0.7
0	31	23.8	15.7	10.3	4	2.7	
2000	31	23.8	15.7	10.3	4	2.7	

Lead 20

Orientation	Horizontal				Vertical		
	Acceleration (G)						
Speed (mm/s)	0.3	0.5	0.7	1.0	0.3	0.5	0.7
0	76	58	37.3	22	13	10.3	7.6
1000	76	58	37.3	22	13	10.3	7.6

Lead 10

Orientation	Horizontal			Vertical	
	Acceleration (G)				
Speed (mm/s)	0.3	0.5	0.7	0.3	0.5
0	103	77.8	49	31	25.6
500	103	77.8	49	31	25.6

Stroke and maximum speed

Stroke	1000~1750 (50-mm increment)	1800 (mm)	1850 (mm)	1900 (mm)	1950 (mm)	2000 (mm)	2050 (mm)	2100 (mm)	2150 (mm)	2200 (mm)	2250 (mm)	2300 (mm)	2350 (mm)	2400 (mm)	2450 (mm)	2500 (mm)
Lead (mm)																
40				1500						1486	1431	1378	1329	1282	1237	1195
20	1000	991	948	909	871	836	803	772	743	715	689	664	641	619	598	578
10	500	495	474	454	436	418	402	386	371	358	345	332	320	309	299	289

(Unit: mm/s)

Dimensions

(Note) The slider moves to the M.E. during home return. Pay attention to prevent contact between the slider and surrounding parts.

CAD drawings can be downloaded from our website.
www.elecylinder.de



ST: Stroke
M.E.: Mechanical end
S.E.: Stroke end

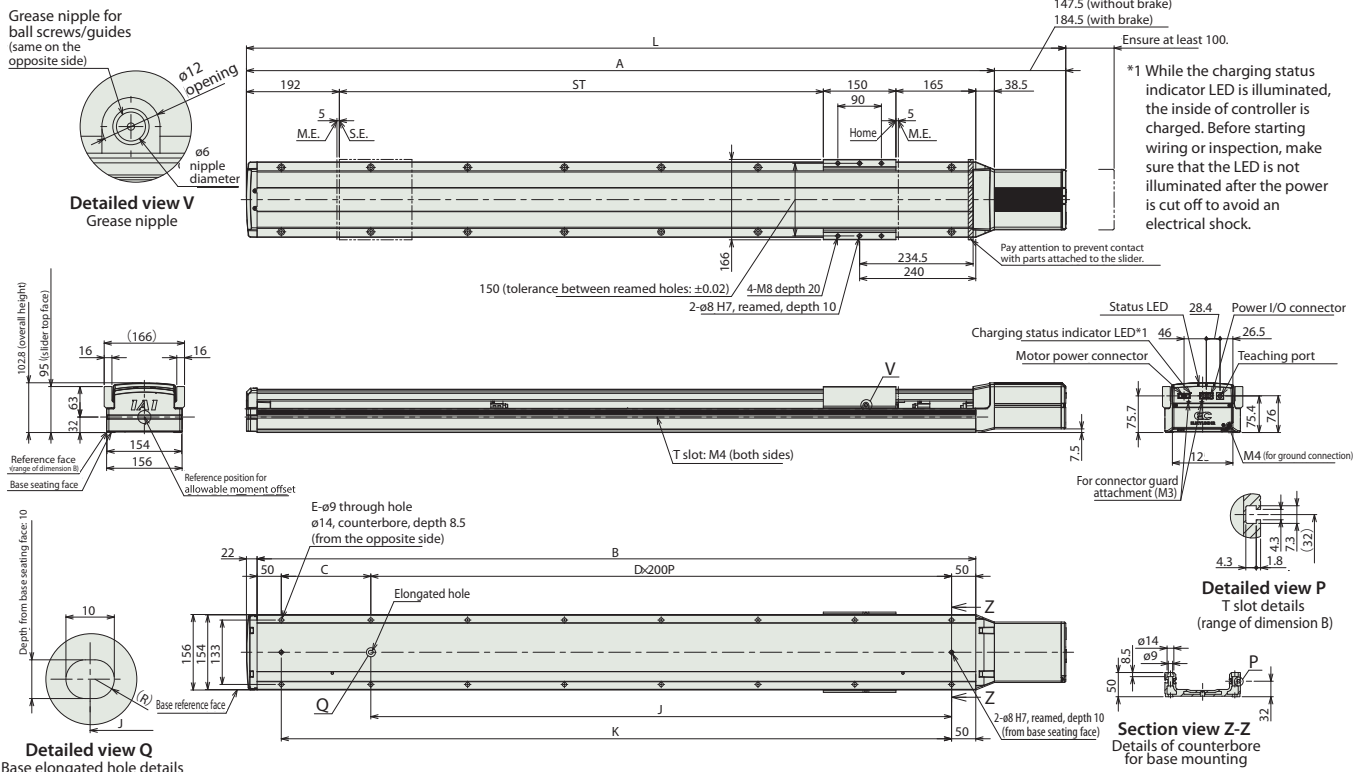

Dimension by stroke

Stroke	1000	1050	1100	1150	1200	1250	1300	1350	1400	1450	1500	1550	1600	1650	1700	1750	1800	1850	1900	1950	2000	2050	2100	2150	2200	2250	2300	2350	2400	2450	2500	
L	Without brake	1693	1743	1793	1843	1893	1943	1993	2043	2093	2143	2193	2243	2293	2343	2393	2443	2493	2543	2593	2643	2693	2743	2793	2843	2893	2943	2993	3043	3093	3143	3193
	With brake	1730	1780	1830	1880	1930	1980	2030	2080	2130	2180	2230	2280	2330	2380	2430	2480	2530	2580	2630	2680	2730	2780	2830	2880	2930	2980	3030	3080	3130	3180	3230
A	1545.5	1595.5	1645.5	1695.5	1745.5	1795.5	1845.5	1895.5	1945.5	1995.5	2045.5	2095.5	2145.5	2195.5	2245.5	2295.5	2345.5	2395.5	2445.5	2495.5	2545.5	2595.5	2645.5	2695.5	2745.5	2795.5	2845.5	2895.5	2945.5	2995.5	3045.5	
B	1485	1535	1585	1635	1685	1735	1785	1835	1885	1935	1985	2035	2085	2135	2185	2235	2285	2335	2385	2435	2485	2535	2585	2635	2685	2735	2785	2835	2885	2935	2985	
C	185	235	285	335	385	435	485	535	585	635	685	735	785	835	885	935	985	1035	1085	1135	1185	1235	1285	1335	1385	1435	1485	1535	1585	1635	1685	
D	6	6	6	6	7	7	7	7	8	8	8	8	9	9	9	9	10	10	10	10	11	11	11	11	12	12	12	12	13	13	13	
E	16	16	16	16	18	18	18	18	20	20	20	20	22	22	22	22	24	24	24	24	26	26	26	26	28	28	28	28	30	30	30	
J	1200	1200	1200	1200	1400	1400	1400	1400	1600	1600	1600	1600	1800	1800	1800	1800	2000	2000	2000	2000	2200	2200	2200	2200	2400	2400	2400	2400	2600	2600	2600	
K	1385	1435	1485	1535	1585	1635	1685	1735	1785	1835	1885	1935	1985	2035	2085	2135	2185	2235	2285	2335	2385	2435	2485	2535	2585	2635	2685	2735	2785	2835	2885	

Weight by stroke

Stroke	1000	1050	1100	1150	1200	1250	1300	1350	1400	1450	1500	1550	1600	1650	1700	1750	1800	1850	1900	1950	2000	2050	2100	2150	2200	2250	2300	2350	2400	2450	2500	
Weight (kg)	Without brake	23.8	24.4	24.9	25.5	26.1	27.4	28.0	28.6	29.2	29.7	30.3	30.9	31.5	32.1	32.6	33.2	33.8	34.4	34.9	35.5	36.1	36.7	37.3	37.8	38.4	39.0	39.6	40.1	40.7	41.3	41.9
	With brake	24.4	25.0	25.6	26.1	26.7	28.0	28.6	29.2	29.8	30.4	30.9	31.5	32.1	32.7	33.2	33.8	34.4	35.0	35.6	36.1	36.7	37.3	37.9	38.5	39.0	39.6	40.2	40.8	41.3	41.9	42.5

Dimensions (double slider specification)

(Note) The slider moves to the M.E. during home return. Pay attention to prevent contact between the slider and surrounding parts.

CAD drawings can be downloaded from our website.
www.elecylinder.de



ST: Stroke
M.E.: Mechanical end
S.E.: Stroke end

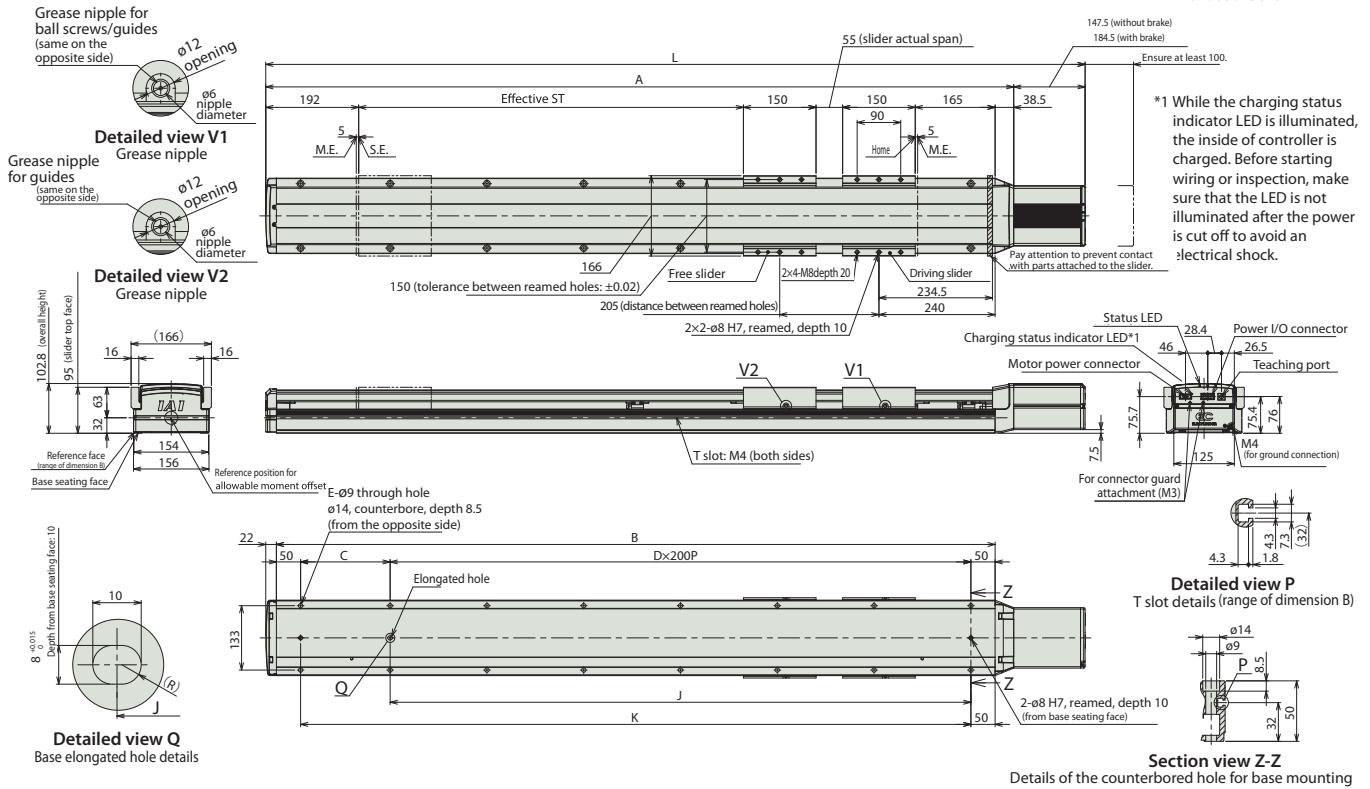

Dimension by stroke

Nominal stroke	1000	1050	1100	1150	1200	1250	1300	1350	1400	1450	1500	1550	1600	1650	1700	1750	1800	1850	1900	1950	2000	2050	2100	2150	2200	2250	2300	2350	2400	2450	2500	
Effective stroke	795	845	895	945	995	1045	1095	1145	1195	1245	1295	1345	1395	1445	1495	1545	1595	1645	1695	1745	1795	1845	1895	1945	1995	2045	2095	2145	2195	2245	2295	
L	Without brake	1693	1743	1793	1843	1893	1943	1993	2043	2093	2143	2193	2243	2293	2343	2393	2443	2493	2543	2593	2643	2693	2743	2793	2843	2893	2943	2993	3043	3093	3143	3193
	With brake	1730	1780	1830	1880	1930	1980	2030	2080	2130	2180	2230	2280	2330	2380	2430	2480	2530	2580	2630	2680	2730	2780	2830	2880	2930	2980	3030	3080	3130	3180	3230
A	1545.5	1595.5	1645.5	1695.5	1745.5	1795.5	1845.5	1895.5	1945.5	1995.5	2045.5	2095.5	2145.5	2195.5	2245.5	2295.5	2345.5	2395.5	2445.5	2495.5	2545.5	2595.5	2645.5	2695.5	2745.5	2795.5	2845.5	2895.5	2945.5	2995.5	3045.5	
B	1485	1535	1585	1635	1685	1735	1785	1835	1885	1935	1985	2035	2085	2135	2185	2235	2285	2335	2385	2435	2485	2535	2585	2635	2685	2735	2785	2835	2885	2935	2985	
C	185	235	285	335	385	435	485	535	585	635	685	735	785	835	885	935	985	1035	1085	1135	1185	1235	1285	1335	1385	1435	1485	1535	1585	1635	1685	
D	6	6	6	6	7	7	7	7	8	8	8	8	8	9	9	9	9	10	10	10	10	11	11	11	11	12	12	12	13	13	13	
E	16	16	16	16	18	18	18	18	20	20	20	20	22	22	22	22	24	24	24	24	26	26	26	26	28	28	28	28	30	30	30	
J	1200	1200	1200	1200	1400	1400	1400	1400	1600	1600	1600	1600	1800	1800	1800	1800	2000	2000	2000	2000	2200	2200	2200	2200	2400	2400	2400	2400	2600	2600	2600	
K	1385	1435	1485	1535	1585	1635	1685	1735	1785	1835	1885	1935	1985	2035	2085	2135	2185	2235	2285	2335	2385	2435	2485	2535	2585	2635	2685	2735	2785	2835	2885	

(Note) Nominal stroke: stroke specified in the model code.
Effective stroke: Actual stroke operable

Weight by stroke

Nominal stroke	1000	1050	1100	1150	1200	1250	1300	1350	1400	1450	1500	1550	1600	1650	1700	1750	1800	1850	1900	1950	2000	2050	2100	2150	2200	2250	2300	2350	2400	2450	2500	
Effective stroke	795	845	895	945	995	1045	1095	1145	1195	1245	1295	1345	1395	1445	1495	1545	1595	1645	1695	1745	1795	1845	1895	1945	1995	2045	2095	2145	2195	2245	2295	
Weight (kg)	Without brake	26.6	27.2	27.7	28.3	28.9	30.2	30.8	31.4	32.0	32.5	33.1	33.7	34.3	34.9	35.4	36.0	36.6	37.2	37.7	38.3	38.9	39.5	40.1	40.6	41.2	41.8	42.4	42.9	43.5	44.1	44.7
	With brake	27.2	27.8	28.4	28.9	29.5	30.8	31.4	32.0	32.6	33.2	33.7	34.3	34.9	35.5	36.0	36.6	37.2	37.8	38.4	38.9	39.5	40.1	40.7	41.3	41.8	42.4	43.0	43.6	44.1	44.7	45.3

(Note) Weight that is added by 1.7kg of the free slider weight to the single slider specification.

Compatible controller

(Note) The EC series uses a built-in controller. For details about the built-in controller, refer to page 32.
The "PSA-200" DC motor power unit is required for any EleCylinder that uses 230V servo motors. Refer to page 34 for details about the PSA-200.

Options for the EleCylinder series

RCON-EC connection specification * Cannot be selected together with TMD2 or PN option. (ACR option includes double power circuit specification.)

Model **ACR**

Description This option is selected when connecting to the field network via RCON-EC for R-unit (RCON/RSEL/REC).

Brake

Model **B**

Description This is a mechanism to keep the slider from moving during power OFF or servo OFF.

Hanging fixture

Model **EB**

Description A set of a hanging fixture and eye bolts to lift the actuator for installation. * Refer to the operation manual for details.

Specified grease application specification

Model **G5**

Description The grease applied on the ball screws, linear guide and intermediate support area of actuator is changed to grease for food-related machines (white alcom grease).

Reversed-home specification

Model **NM**

Description Normally the home position is set on the motor side. However, the home position can be set on the reverse side if so required by the layout of the equipment, etc.

PNP specification * Cannot be selected together with ACR option since ACR option has NPN specification.

Model **PN**

Description All models in the EC series are of the NPN specification, meaning that input/output specification for connecting external equipment is standard. By specifying this option, the models can support the PNP input/output specification.

Double power circuit specification * Cannot be selected together with ACR option. (RCON-EC connection specification comes with double power circuit.)

Model **TMD2**

Description This is an option with actuator operation stop input. To cut off only actuator drive source, select this option. For details of wiring, refer to page 33.

Double slider

Model **W**

Description An option to add a free slider that is not connected to the ball screw. Double slider can increase allowable moment and overhang load length.

Wireless communication specification

Model **WL**

Description This is an option for compatibility with wireless communication. By selecting this option, wireless communication between teaching box and TB-03 becomes available. Start point, end point and AVD can be adjusted via wireless communication.

Wireless axis operation compatible specification

Model **WL2**

Description By selecting WL2, operation tests of axis movement (movement to the front end/rear end, jog and inching) can be performed in addition to the operation (adjustment of start point, end point and AVD) that can be performed with WL wireless communication. However, this is not a function for automatic operation. (Note) The modification from WL to WL2, or from WL2 to WL, cannot be done by a customer. Please contact us.

Duty

Operate with duty ratio of allowable value or less.

Duty ratio is a utilization ratio represented in % to show the time of actuator operation in one cycle.

⚠ Caution: When overload error occurs, lower duty by extending stopping time or lower acceleration/deceleration.

Duty Calculation Method

Calculate load factor and acceleration/deceleration time ratio to read the duty ratio from the graph.

When load factor is 50% or less, operation with 100% duty ratio (continuous operation) is possible.

1 Load factor LF

For maximum payload at rated acceleration and rated acceleration/deceleration, refer to the specification page of the product.

When command acceleration/deceleration is lower than or equal to the rated acceleration/deceleration

$$\text{Load factor : LF} = \frac{M \times \alpha}{M_r \times \alpha_r} [\%]$$

Maximum payload at rated acceleration : M_r [kg]
 Rated acceleration/deceleration : α_r [G]
 Transferring mass during operation : M [kg]
 Acceleration/deceleration during operation : α [G]

When command acceleration/deceleration is higher than or equal to the rated acceleration/deceleration

$$\text{Load factor : LF} = \frac{M \times \alpha}{M_d \times \alpha} = \frac{M}{M_d} [\%]$$

Payload at command acceleration : M_d [kg]
 Transferring mass during operation : M [kg]
 Acceleration/deceleration during operation : α [G]

2 Acceleration/deceleration time ratio t_{od}

$$\text{Acceleration/deceleration time ratio } t_{od} = \frac{\text{Acceleration time during operation} + \text{deceleration time during operation}}{\text{Operating time operation}} [\%]$$

$$\text{Acceleration time} = \frac{\text{Speed during operation [mm/s]}}{\text{Acceleration during operation [mm/s}^2]} [\text{sec}]$$

$$\text{Deceleration time} = \frac{\text{Speed during operation [mm/s]}}{\text{Deceleration during operation [mm/s}^2]} [\text{sec}]$$

$$\text{Acceleration [mm/s}^2] = \text{Acceleration[G]} \times 9800 \text{mm/s}^2$$

$$\text{Deceleration [mm/s}^2] = \text{Deceleration[G]} \times 9800 \text{mm/s}^2$$

3 Duty ratio: Read duty ratio from the calculated load factor LF and acceleration/deceleration time ratio t_{od} .

Example) When the load factor LF is 80% and acceleration/deceleration time ratio t_{od} is 80%, the rough guide of duty ratio is approx. 75%.

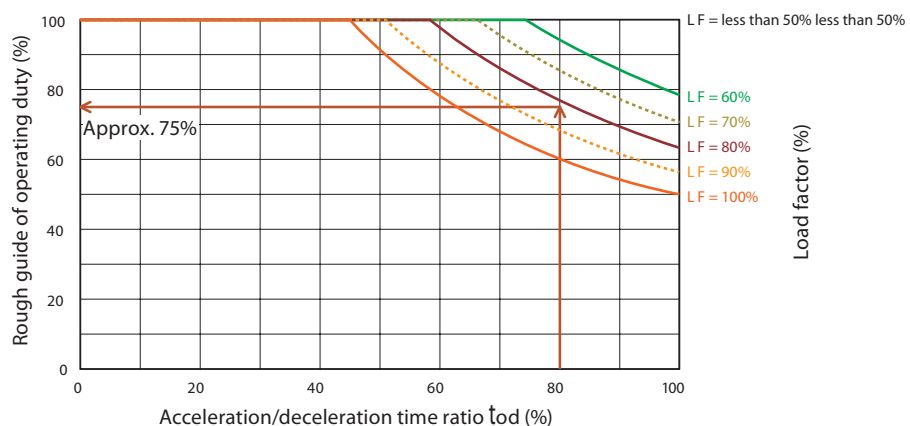

System Configuration

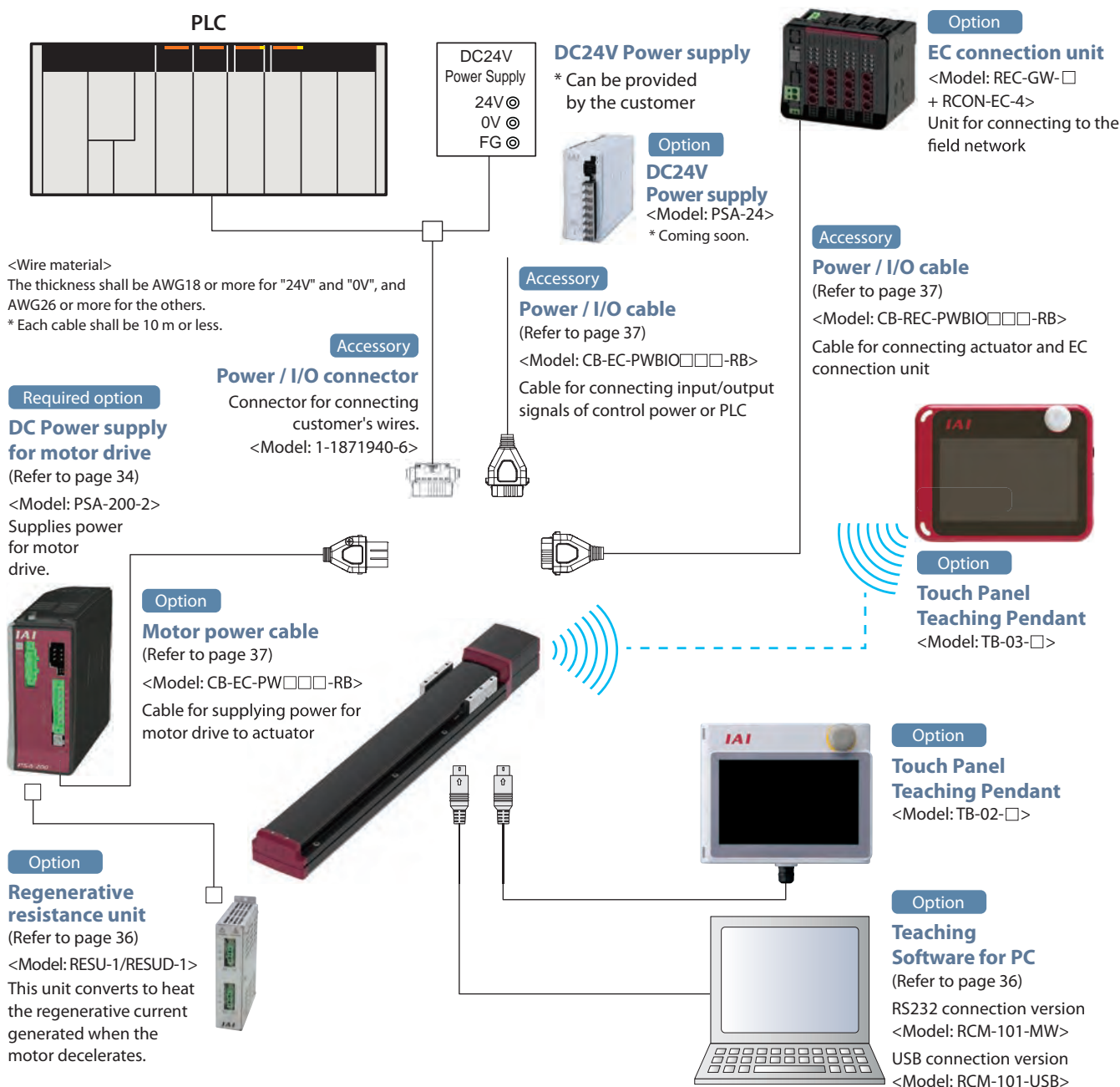

List of Accessories

■ Power / I/O cable

Product classification		Accessory
Power / I/O cable length (selected with actuator model)	Selection of ECON-EC connection specification (ACR)	
0	No	Power / I/O connector (1-1871940-6)
	Yes	-
1 to 10	No	Power / I/O cable (CB-EC-PWBIO□□□-RB)
	Yes	Power / I/O cable (CB-REC-PWBIO□□□-RB)

■ Motor power cable

Product classification		Accessory
Motor power cable length (selected with actuator model)	Selection of ECON-EC connection specification (ACR)	
0	No	-
	Yes	-
1 to 10	No	Motor power cable (CB-EC-PW□□□-RB)
	Yes	

Basic Controller Specifications

Specification item		Specification content	
Number of control axes		1 axis	
Motor power input voltage		Supplied from PSA-200 (DC280V type)	
Control power input voltage		DC24V \pm 10%	
Control power current	Control	320mA	
	Teaching (Note 1)	150mA	
	Brake (Note 2)	[S10(X)] 220mA (no overexcitation) [S13(X),S15(X)] Overexcitation: 875mA, normal: 85mA	
Control power capacity	Control	7.6W	
	Teaching (Note 1)	3.6W	
	Brake (Note 2)	[S10(X)] 5.3W (no overexcitation) [S13(X),S15(X)] Overexcitation: 21.0W, normal: 2.0W	
Rush current		-	
Momentary power failure resistance		max 500 μ s	
Compatible motor wattage		200W/400W	
Motor control method		Sine wave PWM vector current control	
Compatible encoder		Battery-less absolute encoder (16384 pulse/rev)	
SIO		RS485 1ch (Modbus protocol compliant)	
PIO	Input specification	Number of input points	3 points (forward, backward, alarm reset)
		Input voltage	DC24V \pm 10%
		Input current	5mA/circuit
		Leak current	Maximum 1mA/point
		Isolation method	Non-isolation
	Output specification	Number of output points	3 points (forward movement completion, backward movement completion, alarm)
		Output voltage	DC24V \pm 10%
		Output current	50mA/point
		Residual voltage	2V or less
		Isolation method	Non-isolation
Data setting, input method		Teaching software exclusively for PC, touch panel teaching pendant	
Data retention memory		Storing position and parameters in non-volatile memory (no limitation on the number of writing)	
LED indicator	Controller status indicator (right)	Servo ON (green light ON) / alarm (red light ON) / during initialization after power ON (orange light ON) / minor failure alarm (green light flickering) / operation from teaching: stop from teaching (red light ON) / servo OFF (illumination OFF)	
	Motor power status indicator (middle)	Motor power ON (green light ON) / motor power OFF (green light flickering)	
	Wireless mode indicator (left)	During wireless hardware initialization, no wireless connection, or during connection from TP port (illumination OFF) during wireless connection (green light flickering) / wireless hardware malfunction (red light flickering) / during initialization after power ON (orange light ON)	
	Charging status indicator (next to IO connector)	Internal circuit charging state (red light ON) / internal circuit non-charging state (illumination OFF) (Note 3)	
Predictive/preventative maintenance		When the number of movements or travelling distance exceeds the set value or overload warning is issued, LED (right side) flickers in green. * Only when the setting is done in advance	
Ambient operating temperature		0 to 40 °C	
Ambient operating humidity		85% RH max. (no condensation or freezing)	
Operating environment		Free from corrosive gasses, in particular not exposed to heavy dust	
Isolation resistance		500VDC 10 M Ω	
Protection against electrical shock		Class I basic isolation	
Cooling method		Natural air cooling	

(Note 1) Add this when connecting teaching pendant.

(Note 2) Add this when using actuator with brake.

(Note 3) While the charging status indicator LED is illuminated, the inside of controller is charged. Before starting wiring or inspection, make sure that the LED is not illuminated after the power is cut off to avoid an electrical shock.

Solenoid valve method

EleCylinder usually employs the double solenoid method.

For the single solenoid method, change Parameter No.9 "Solenoid valve method selection."

<Caution> When it is connected to RCON-EC, operations cannot be performed in the single solenoid method.

I/O Specification (Input/Output specifications)

I/O		Input part		Output part	
Specifications		Input voltage	24 VDC ±10%	Load voltage	24 VDC ±10%
		Input current	5 mA/circuit	Maximum load current	50 mA/point
		ON/OFF voltage	ON voltage minimum 18 VDC OFF voltage maximum 6 VDC	Residual voltage	2 V or less
		Leak current	Maximum 1 mA/point	Leak current	Maximum 0.1 mA/point
Isolation method		Non-isolation from external circuit		Non-isolation from external circuit	
I/O logic	NPN				
	PNP				

(Note) Isolation method is non-isolation. Grounding of external device (PLC, etc.) connected to EleCylinder shall be common with grounding of EleCylinder.

I/O Specification Wiring Diagram

I/O		Standard specification	Double power circuit specification (option model: TMD2)
Power / I/O connector		<p>0V A1 (Reserve) A2 Backward movement completion A3 Forward movement completion A4 Alarm output A5 (Reserve) A6</p> <p>B1 24V B2 Brake release B3 Backward movement command** B4 Forward movement command** B5 Alarm reset B6 (Reserve)</p>	<p>In TMD2 specification, actuator operation stop input is included, but drive source is not cut off. To cut off drive source, AC power supply (L1, L2) of separate PSA-200 needs to be cut off.</p> <p>0V A1 24V (Control) A2 Backward movement completion A3 Forward movement completion A4 Alarm output A5 (Reserve) A6</p> <p>B1 24V (Stop)* B2 Brake release B3 Backward movement command** B4 Forward movement command** B5 Alarm reset B6 (Reserve)</p>
I/O logic	NPN		
	PNP		

* When 24-V supply to "Stop" stops, axis operation stops. (Drive source is not cut off.)

** When the single solenoid method is used, B3 is "Forward/Backward command" and B4 is not used.

I/O Signal Table

Power / I/O connector pin assignment			
Pin No.	Connector tag plate name	Signal abbreviation	Function overview
B3 (Note 1)	Backward	ST0	Backward movement command
B4 (Note 1)	Forward	ST1	Forward movement command
B5	Alarm reset	RES	Alarm reset
A3	Backward movement completion	LS0	Backward movement completion
A4	Forward movement completion	LS1	Forward movement completion
A5	Alarm	*ALM	Alarm detection (contact b)
B2	Brake release	BKRLS	Forced brake release(for specifications with a brake)
B1 (Note 2)	24V	24V	24V input
A1	0V	0V	0V input
A2 (Note 2)	(24V)	(24V)	24V input

(Note 1) When the single solenoid method is used, B3 is "Forward/Backward command" and B4 is not used.

However, power I/O connector is unchanged showing B3: Backward and B4: Forward.

(Note 2) For double power circuit specification (TMD2), B1 is 24 V (Stop), and A2 is 24 V (Control).

Required Option

DC Power Supply for Motor Drive

Features Unit to supply DC power for drive to motor of actuator. One unit can supply power to axes up to 6. (not exceeding the maximum wattage with axes connected)

Model **PSA-200-2**
(Input voltage: single phase 230 VAC. Axes up to 1600W can be connected.)

Configuration Connected with motor power cable



Wattage of motor equipped in actuator

<Recommended model>
NF2010A-UP (Manufacturer: Soshin Electric)
NAC-10-472 (Manufacturer: COSEL)

EC-S10/S10X	100W
EC-S13/S13X	200W
EC-S15/S15X	400W

Specification

Power input voltage range	Single phase 230 VAC specification: 200 to 230 VAC ±10%
Input frequency range	50Hz ±5%
Rush current (Note 1)	55°C Control power: 60A Motor power: 70 A
Output voltage	DC280V type
Maximum wattage with motors connected	Single phase 230 VAC specification: 1600W
Maximum number of drivable axes	6 axes
Momentary power failure resistance	50Hz: 20 ms
Isolation withstand voltage	Between primary and FG 1500 VAC for 1 min
Isolation resistance	Between secondary and FG 500 VDC 10 MΩ or more
Leak current	Total 3.1 mA (When the recommended noise filter is used and 6 axes are connected)
Protection against electrical shock	Class I basic isolation

(Note 1) Rush current flows for approx. 20 ms after power ON. Take note that the rush current value varies depending on impedance of power line and internal element temperature (thermistor).

Name of each part

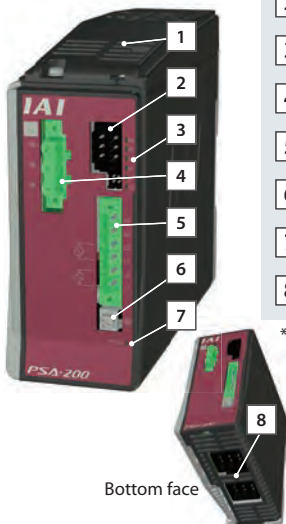

- 1 Fan unit
- 2 Status output connector
- 3 Status indicator LED
- 4 Regenerative unit connection connector
- 5 Power connector
- 6 Ground terminal
- 7 Charging status indicator LED *1
- 8 Motor power connector

*1 While the charging status indicator LED is illuminated, the inside of PSA-200 is charged. Before starting wiring or inspection, make sure that the LED is not illuminated after the power is cut off to avoid an electrical shock.

External dimensions

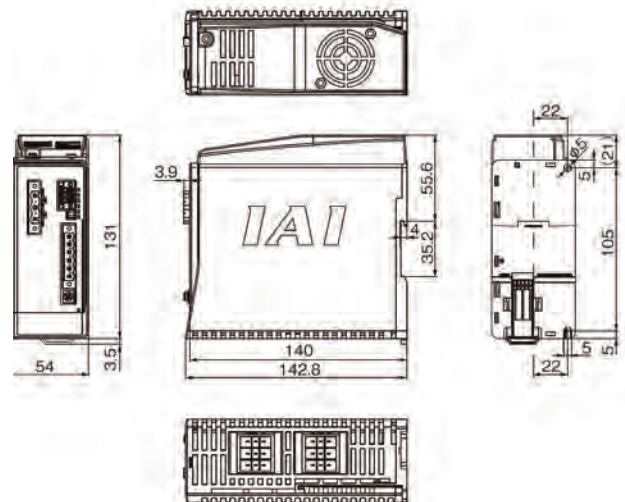

Options

Regenerative Resistance Unit

Features Unit to convert regenerative current generated when the motor decelerates into heat. Calculate total wattage of operating actuators, and refer to "rough guide of required regenerative resistance units" on the right. If required, purchase regenerative resistance units.

Model **RESU-1** (standard specification) **RESUD-1** (DIN rail installation specification)

Configuration	Model	RESU-1	RESUD-1
Main body weight	Approx. 0.4 kg		
Built-in regenerative resistor value	235Ω 80W		
Method of installation to main body	Screw fixed	DIN rail fixed	
Supplied cable	CB-SC-REU010		

Rough guide of required regenerative resistance units

Wattage of motor equipped in actuator

EC-S10/S10X	100W
EC-S13/S13X	200W
EC-S15/S15X	400W



Wattage	Horizontal									
	0	200	400	600	800	1000	1200	1400	1600	
Vertical	0	0	0	0	0	0	1	1	1	1
	200	0	1	1	1	1	1	1	1	-
	400	1	1	1	1	2	2	2	-	-
	600	1	1	2	2	2	2	-	-	-
	800	1	2	2	2	2	-	-	-	-
	1000	2	2	2	2	-	-	-	-	-
	1200	2	2	3	-	-	-	-	-	-
	1400	2	3	-	-	-	-	-	-	-
	1600	3	-	-	-	-	-	-	-	-

External dimensions

<RESU-1>

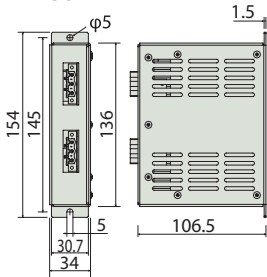

<RESUD-1>

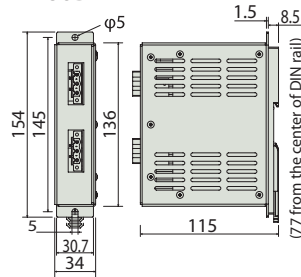

<Note>

- The table above shows rough guide for back-and-forth operation at rated acceleration/deceleration with rated load, 1000 mm of stroke and 50% of operating duty ratio.
- Regenerative energy is also absorbed inside the controller. However, when regenerative energy exceeds the allowable level, excessive estimated regenerative power discharge alarm is set off. In such a case, externally connect additional regenerative resistor units. When the operating duty is higher than 50 % or load is higher due to vertical installation, more regenerative resistor units than those shown in the table above are required. Note that the maximum number of regenerative resistor units that can be connected is five. Never connect regenerative resistor units more than five as this may cause malfunction.
- Use calculation software to know the optimum number of units for the operating condition.

Touch Panel Teaching Pendant for both wireless and wired connections

Features Teaching device compatible with wireless connection. Input of start point, end point and AVD or axis operation can be performed via wireless connection.

Model **TB-03** For compatible versions, refer to our website.

Configuration Wireless or wired connection

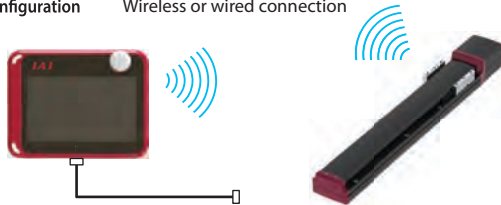

Specification

Rated voltage	24V DC
Power consumption	3.6 W or less (150 mA or less)
Ambient operating temperature	0 to 40 °C
Ambient operating humidity	20 to 85% RH (no condensation)
Environmental resistance	IPX0
Weight	Approx. 485 g (main body) + approx. 175 g (battery)
Charging method	Dedicated adapter / wired connection to controller
Wireless connection	Bluetooth 4.2 class 2

Teaching Software for PC (Windows only)

Features The start-up support software which comes equipped with functions such as position teaching, trial operation, and monitoring. A complete range of functions needed for making adjustments contributes to shortened start-up time.

Model **RCM-101-MW** (with an external device communication cable + RS232 conversion unit)

Please contact IAI for the current supported versions.

Configuration



Your dedicated cable [RCB-CV-MW/CB-RCA-SIO050]



Model **RCM-101-USB** (with an external device communication cable + USB conversion adapter + USB cable)

Please contact IAI for the current supported versions.

Configuration

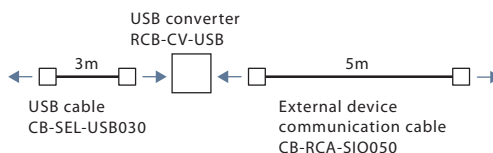

Maintenance Parts

When service parts need to be ordered due to cable replacement, etc., after purchasing the product, refer to the cable models below.

Table of compatible cable

Cable type	Cable model name
Power / I/O Cable (user wiring specification)	CB-EC-PWBIO□□□-RB
Power / I/O Cable (RCON-EC connection specification)	CB-REC-PWBIO□□□-RB
Motor power cable	CB-EC-PW□□□-RB

Model CB-EC-PWBIO□□□-RB

* Enter cable length (L) in □□□.
Example) 030: 3 m

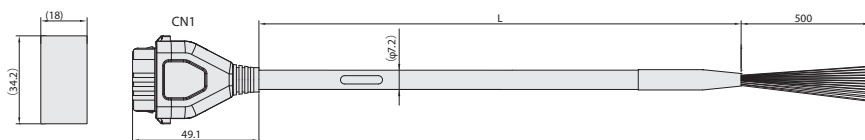

Actuator side Minimum bending R, r = 58 mm or more (when flexible cable is used)
* Robot cable is standard.

Color	Signal name	Pin No.
Black (AWG18)	0V	A1
Red (AWG18)	24V	B1
Light blue (AWG22)	(Reserve/Note 1)	A2
Orange (AWG26)	INO	B3
Yellow (AWG26)	IN1	B4
Green (AWG26)	IN2	B5
Pink (AWG26)	(Reserve)	B6
Blue (AWG26)	OUT0	A3
Purple (AWG26)	OUT1	A4
Gray (AWG26)	OUT2	A5
White (AWG26)	(Reserve)	A6
Brown (AWG26)	BKRLS	B2

(Note 1) When double power circuit specification (TMD2) is selected, this becomes 24 V (Control).

Model CB-REC-PWBIO□□□-RB

* Enter cable length (L) in □□□.
Example) 030: 3 m

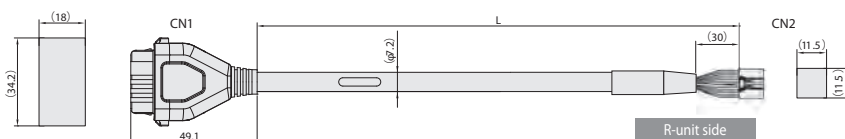

Actuator side Minimum bending R, r = 58 mm or more (when flexible cable is used)
* Robot cable is standard.

Color	Signal name	Pin No.	Pin No.	Signal name	Color
Black (AWG18)	0V	A1	2	0V	Black (AWG22)
Red (AWG18)	24V(MP)	B1	1	24V(MP)	Red (AWG22)
Light blue (AWG22)	24V(CP)	A2	12	24V(CP)	Light blue (AWG22)
Orange (AWG26)	INO	B3	7	OUT0	Orange (AWG26)
Yellow (AWG26)	IN1	B4	8	OUT1	Yellow (AWG26)
Green (AWG26)	IN2	B5	9	OUT2	Green (AWG26)
Light green (AWG26)	SD+	B6	6	SD+	Light green (AWG26)
Light gray (AWG26)	SD-	A6	10	SD-	Light gray (AWG26)
Blue (AWG26)	OUT0	A3	3	INO	Blue (AWG26)
Purple (AWG26)	OUT1	A4	4	IN1	Purple (AWG26)
Gray (AWG26)	OUT2	A5	5	IN2	Gray (AWG26)
Brown (AWG26)	BKRLS	B2	11	BKRLS	Brown (AWG26)
			13	FG	Green (AWG26)

Model CB-EC-PW□□□-RB

* Enter cable length (L) in □□□.
Example) 030: 3 m

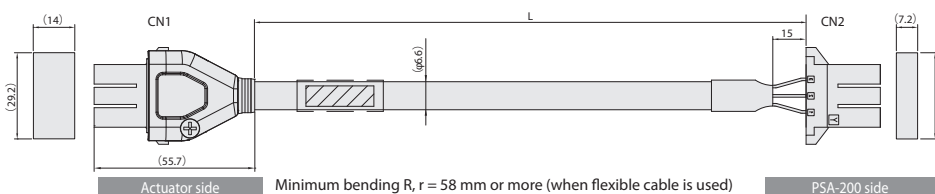

Actuator side Minimum bending R, r = 58 mm or more (when flexible cable is used)
* Robot cable is standard.

PSA-200 side

Color	Signal name	Pin No.	Pin No.	Signal name	Color
Red (AWG18)	MP	1	1	MP	Red (AWG18)
Black (AWG18)	MN	2	2	MN	Black (AWG18)
Green/yellow (AWG18)	PE	3	3	PE	Green/yellow (AWG18)

Maintenance parts schematic drawing

S10(X)/S13(X)/S15(X) types

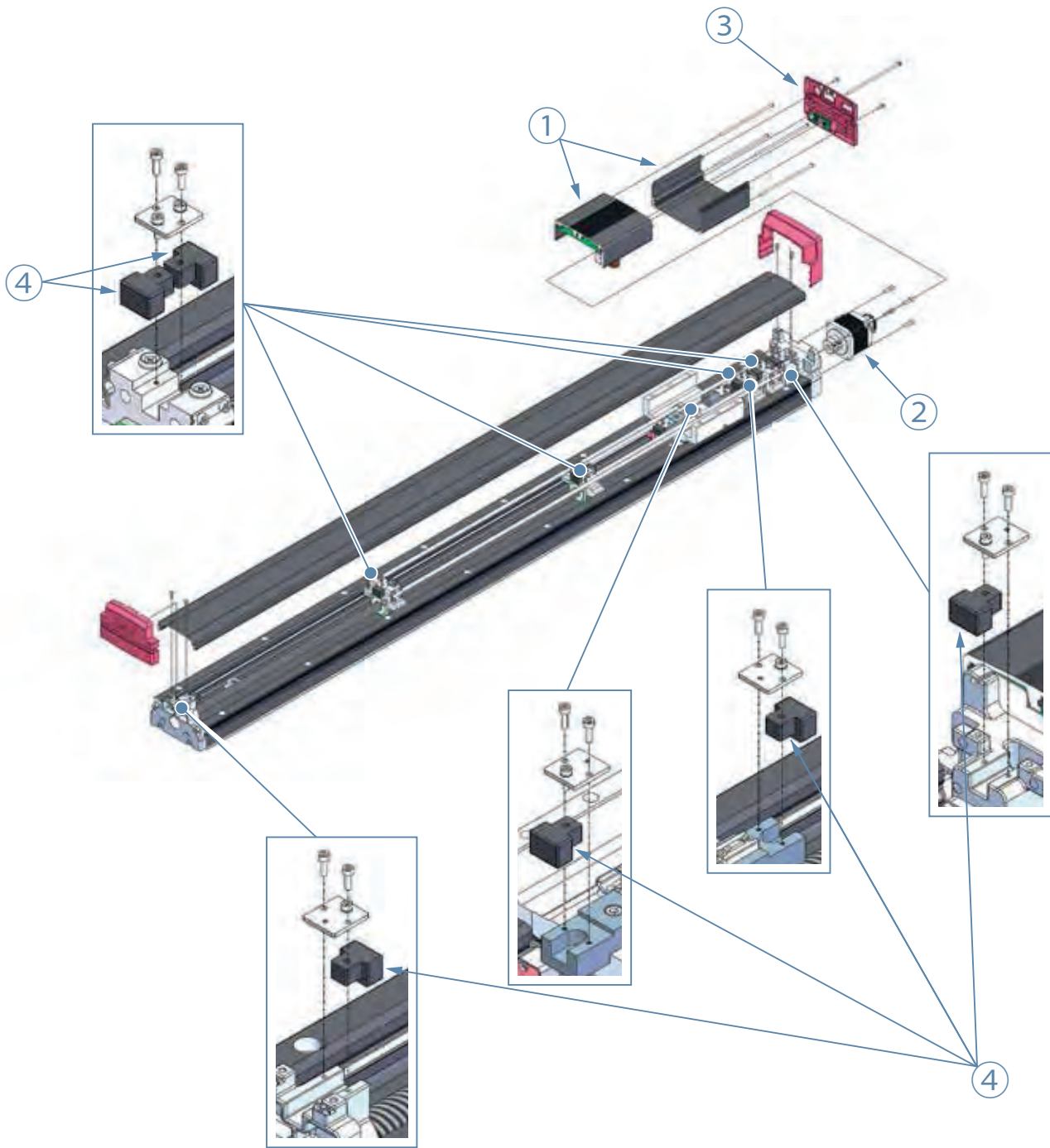

- ① Motor cover Assy (including controller circuit board)
- ② Motor unit
- ③ End cover Assy (with wireless communication circuit board cable)
- ④ Intermediate support cushion

List of models of maintenance parts

S10(X)/S13(X)/S15(X) types

① -1 Motor cover Assy Common with the WL specification *

Type	Brake	I/O	Model code
S10 S10X	No	NPN	MWB-EC-S10
		PNP	MWB-EC-S10-P
	Yes	NPN	MWB-EC-S10B
		PNP	MWB-EC-S10B-P
S13 S13X	No	NPN	MWB-EC-S13
		PNP	MWB-EC-S13-P
	Yes	NPN	MWB-EC-S13BS15
		PNP	MWB-EC-S13BS15-P
S15 S15X	No	NPN	MWB-EC-S13BS15
		PNP	MWB-EC-S13BS15-P
	Yes	NPN	MWB-EC-S15B
		PNP	MWB-EC-S15B-P

* Not include wireless communication driver board.

① -2 Motor cover Assy Wireless axis operation specification (WL2) *

Type	Brake	I/O	Model code
S10 S10X	No	NPN	MWB-EC-S10-WL2
		PNP	MWB-EC-S10-P-WL2
	Yes	NPN	MWB-EC-S10B-WL2
		PNP	MWB-EC-S10B-P-WL2
S13 S13X	No	NPN	MWB-EC-S13-WL2
		PNP	MWB-EC-S13-P-WL2
	Yes	NPN	MWB-EC-S13BS15-WL2
		PNP	MWB-EC-S13BS15-P-WL2
S15 S15X	No	NPN	MWB-EC-S13BS15-WL2
		PNP	MWB-EC-S13BS15-P-WL2
	Yes	NPN	MWB-EC-S15B-WL2
		PNP	MWB-EC-S15B-P-WL2

* Not include wireless communication driver board.

① -3 Motor cover Assy for 2-power supply system Common with WL specification *

Type	Brake	I/O	Model code
S10 S10X	No	NPN	MWB-EC-S10-TMD2
		PNP	MWB-EC-S10-P-TMD2
	Yes	NPN	MWB-EC-S10B-TMD2
		PNP	MWB-EC-S10B-P-TMD2
S13 S13X	No	NPN	MWB-EC-S13-TMD2
		PNP	MWB-EC-S13-P-TMD2
	Yes	NPN	MWB-EC-S13BS15-TMD2
		PNP	MWB-EC-S13BS15-P-TMD2
S15 S15X	No	NPN	MWB-EC-S13BS15-TMD2
		PNP	MWB-EC-S13BS15-P-TMD2
	Yes	NPN	MWB-EC-S15B-TMD2
		PNP	MWB-EC-S15B-P-TMD2

* Not include wireless communication driver board.

① -4 Motor cover Assy for double power circuit Wireless axis operation specification (WL2) *

Type	Brake	I/O	Model code
S10 S10X	No	NPN	MWB-EC-S10-TMD2-WL2
		PNP	MWB-EC-S10-P-TMD2-WL2
	Yes	NPN	MWB-EC-S10B-TMD2-WL2
		PNP	MWB-EC-S10B-P-TMD2-WL2
S13 S13X	No	NPN	MWB-EC-S13-TMD2-WL2
		PNP	MWB-EC-S13-P-TMD2-WL2
	Yes	NPN	MWB-EC-S13BS15-TMD2-WL2
		PNP	MWB-EC-S13BS15-P-TMD2-WL2
S15 S15X	No	NPN	MWB-EC-S13BS15-TMD2-WL2
		PNP	MWB-EC-S13BS15-P-TMD2-WL2
	Yes	NPN	MWB-EC-S15B-TMD2-WL2
		PNP	MWB-EC-S15B-P-TMD2-WL2

* Not include wireless communication driver board.

① -5 Motor cover Assy for double power circuit RCON-EC connection spec. (Option code: ACR) Common with WL specification *

Type	Brake	Model code
S10 S10X	No	MWB-EC-S10-ACR
	Yes	MWB-EC-S10B-ACR
S13 S13X	No	MWB-EC-S13-ACR
	Yes	MWB-EC-S13BS15-ACR
S15 S15X	No	MWB-EC-S13BS15-ACR
	Yes	MWB-EC-S15B-ACR

* Not include wireless communication driver board.

① -6 Motor cover Assy for double power circuit RCON-EC connection spec. (Option code: ACR) Wireless operation specification (WL2) *

Type	Brake	Model code
S10 S10X	No	MWB-EC-S10-ACR-WL2
	Yes	MWB-EC-S10B-ACR-WL2
S13 S13X	No	MWB-EC-S13-ACR-WL2
	Yes	MWB-EC-S13BS15-ACR-WL2
S15 S15X	No	MWB-EC-S13BS15-ACR-WL2
	Yes	MWB-EC-S15B-ACR-WL2

* Not include wireless communication driver board.

② Motor unit

Type	Brake	Model code
S10 S10X	No	EC-MUS10
	Yes	EC-MUS10-B
S13 S13X	No	EC-MUS13
	Yes	EC-MUS13-B
S15 S15X	No	EC-MUS15
	Yes	EC-MUS15-B

③ End cover Assy (with wireless circuit board cable)

Type	Model code
S10 S10X	EWB-EC-S10
S13 S13X S15 S15X	EWB-EC-S13S15

④ Intermediate support cushion *

Type	Model code	Required quantity
S10X	IMSC-EC-S13S15	8 pieces (all strokes)
S13X		8 pieces (800-1000mm stroke) 12 pieces (1050-2000mm stroke)
S15X		8 pieces (1000-1200mm stroke) 12 pieces (1250-2500mm stroke)

* The above model come with 12 pieces.
The customer may dispose or store any excess ones.

**EC EleCylinder Series
Large Slider Type
Catalogue No. 0222-E**

The information contained in this catalog
is subject to change without notice for the
purpose of product improvement



IAI Industrieroboter GmbH

Ober der Röth 4

D-65824 Schwalbach / Frankfurt

Germany

Phone: +49-6196-8895-0

Fax: +49-6196-8895-24

E-Mail: info@IAI-automation.com

Internet: IAI-automation.com

IAI America, Inc.

2690 W. 237th Street, Torrance, CA 90505, U.S.A

Phone: +1-310-891-6015, Fax: +1-310-891-0815

IAI (Shanghai) Co., Ltd

Shanghai Jiahua Business Center A8-303, 808,

Hongqiao Rd., Shanghai 200030, China

Phone: +86-21-6448-4753, Fax: +86-21-6448-3992

IAI CORPORATION

577-1 Obane, Shimizu-Ku, Shizuoka, 424-0103 Japan

Phone: +81-543-64-5105, Fax: +81-543-64-5192

IAI Robot (Thailand) Co., Ltd

825 PhairojKijja Tower 12th Floor, Bangna-Trad RD.,

Bangna, Bangna, Bangkok 10260, Thailand

Phone: +66-2-361-4457, Fax: +66-2-361-4456