

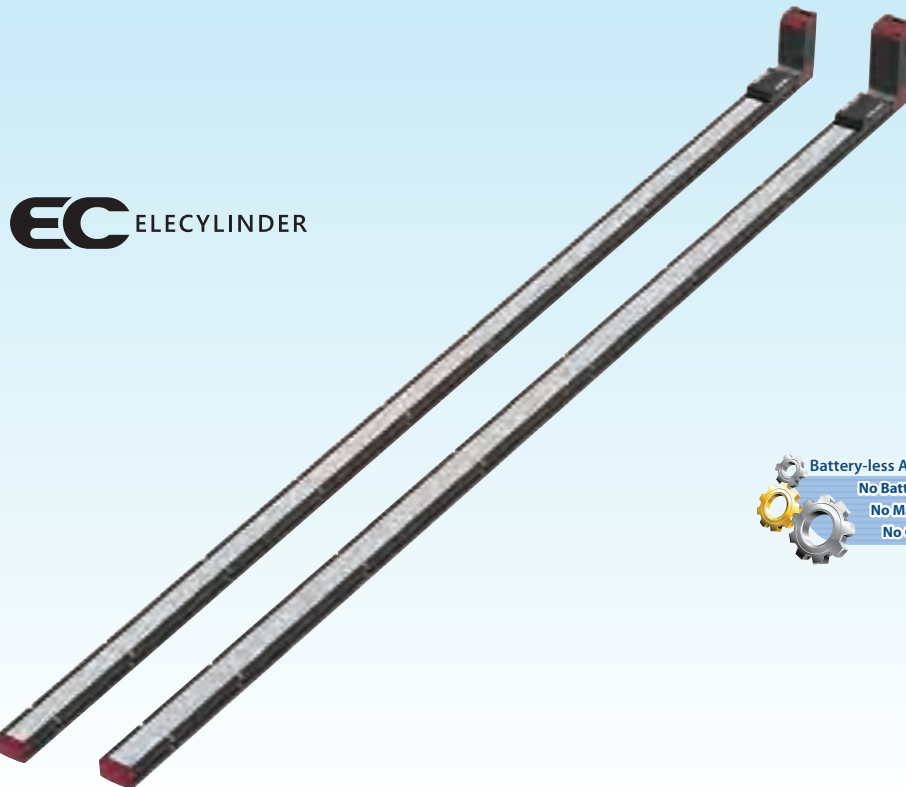

Simple-to-use ELECYLINDER with Built-in Controller
Medium Belt-driven Type with Top-mounted Motor

EC B6/7S

Simple-to-use ELECYLINDER with Built-in Controller
Medium Belt-driven Type with Bottom-mounted Motor

EC B6/7SU



 Battery-less Absolute Encoder
No Battery,
No Maintenance, No Homing,
No Going Back to Incremental.



Simple & Wireless
Operation

2 Position Actuator

2-point positioning

Built-in controller

EleCylinder EC-B6/B7 Belt-driven Type

1

Max. stroke: 2600mm
Max. speed: 1600mm/s

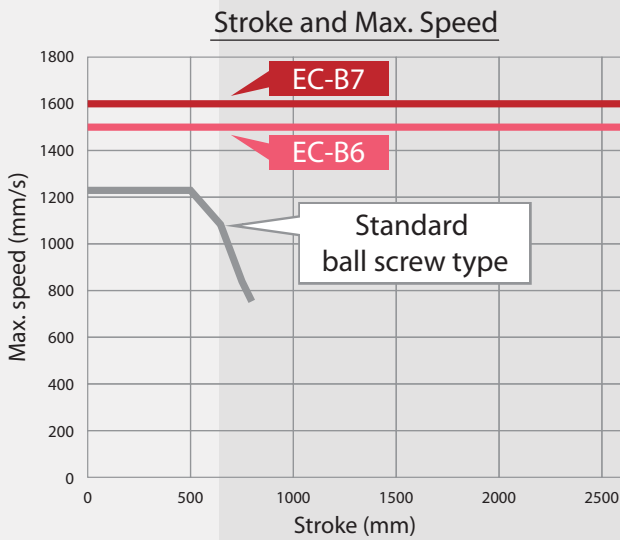

If the stroke increases for the standard ball screw type, the maximum speed will decrease due to the resonance of the ball screw. **EC-B6/7** uses a belt drive system so that the maximum speed does not decrease at a long stroke.

2

Max.
payload: 20kg

Correlation Diagram of
Speed and Payload (Acceleration/deceleration: 0.3G)

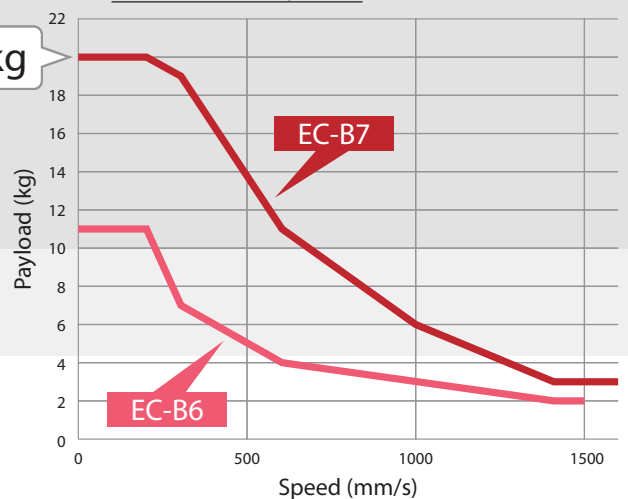

EC-B6

EC-B7



Select a battery-less absolute encoder as an option to eliminate the need to return home at a long stroke!

3

The motor installation direction can also be changed after purchase

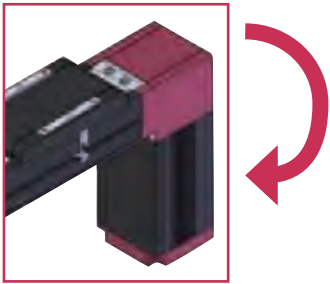

Downward facing motor specification

4

Can be bolted from the top, allowing for easy replacement

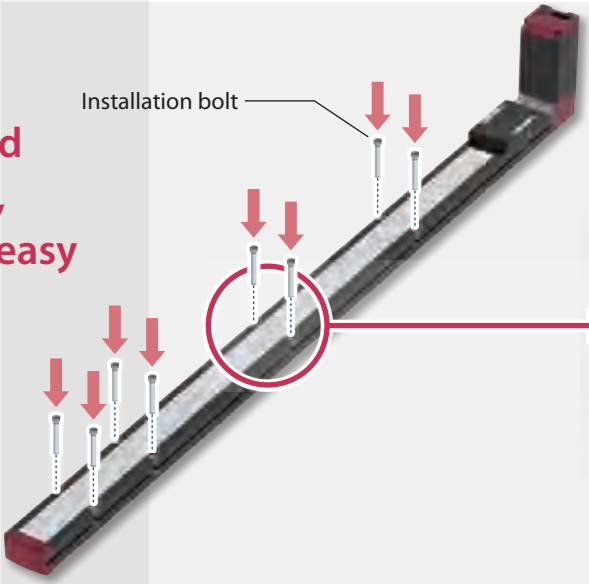

Installation bolt

Installation bolt size
B6: M4, B7: M5



5

Installation orientation
Can be installed in any of the following orientations*

Horizontal on flat surface

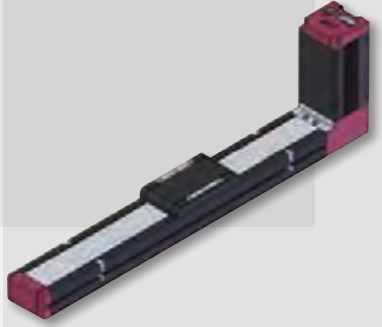

Horizontal side-mounted

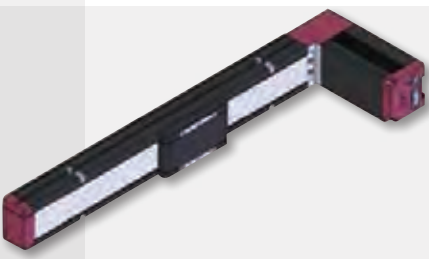

Horizontal suspended



* Installing the product horizontal side-mounted or horizontal suspended may cause slack or misalignment in the stainless steel sheet. Continued use in these orientations can cause the stainless steel sheet to break. Please inspect it daily and adjust the sheet if any slack or misalignment is found.

Model Specifications Items

EleCylinder

EC - [] **S** ([]) - [] - [] - ([])

Series Type Lead Motor coupling method Stroke Cable length Options

B6	Belt-driven type 63mm wide			300	300mm	0	0m	Blank	Incremental encoder specification NPN specification, no options
B7	Belt-driven type 73mm wide			?	?	?	?	B	Brake
S	Lead 48mm equivalent	Blank	Motor top-mounted specification	2600	2600mm (100mm increments)	10	10m	G5	Specified grease applied specification
		U	Motor bottom-mounted specification					NM	Non-motor end specification
WL2	Wireless axis operation specification	WL	Wireless communication specification	WA	Battery-less absolute encoder specification	TMD2	Twin power supply specification		

Cable length
· 0: With power / I/O connector
· 1 ~ 10: Power I/O cable included

Mounting method

- Use the through holes on top of the actuator

○: Can be mounted —: Cannot be mounted

Installation view		Mounting orientation			
Series	Type	Horizontal mounting on flat surface	Horizontal side mounting	Horizontal mounting suspended	Vertical mount
EC	B6	○	○ (*)	○ (*)	—
	B7	○	○ (*)	○ (*)	—

* Installing the product horizontal side mount or horizontal suspended may cause slack or misalignment in the stainless steel sheet. Continued use in these orientations can cause the stainless steel sheet to break. Please inspect it daily and adjust the sheet if any slack or misalignment is found.

- Keep the body installation surface and workpiece mounting surface flatness within 0.05mm/m. Uneven flatness will increase the slider's sliding resistance and may cause malfunction.

Duty Ratio

EC-B6/B7 can be operated at 100% of its duty cycle.
(Ambient temperature 0 to 40°C.)

[Duty Cycle]

Duty cycle is the percentage of the actuator's active operation time in each cycle.

$$D = \frac{T_M}{T_M + T_R} \times 100(\%)$$

D: Duty
T_M: Operating time
(including push-motion operation)
T_R: Stopping time

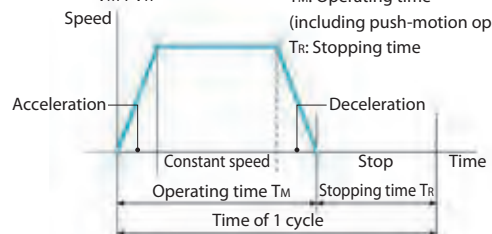

EC-B6S

EC-B6SU

Simple Dust Proof Belt Type Motor Unit Coupled Body width 63 mm 24v Pulse motor

■ Model Specification Items

EC - B6 S [] - [] - [] - []

Series	Type	Lead	Blank	Specification	Stroke	Cable Length	Option	
	S	48mm	Blank	Motor top-mounted	300 ? 2600	300mm ? 2600mm (100mm increments)	0 ? 10	Terminal type with connector 1m ? 10m Refer to option below

CE RoHS

Horizontal Vertical

Side Ceiling



(Note) The above is motor top-mounted type.

Cable Length

Cable code	Cable length
0	Without cable (with connector)
1 ~ 3	1 ~ 3m
4 ~ 5	4 ~ 5m
6 ~ 10	6 ~ 10m

Option

Name	Option code	Reference page
Brake	B	10
Specified grease applied specification*	G5	10
Non-motor end specification	NM	10
PNP specification	PN	10
Twin power supply specification	TMD2	10
Battery-less absolute encoder specification	WA	10
Wireless communication specification	WL	10
Wireless axis operation specification	WL2	10

*Change grease to food grade.

POINT Selection Notes

- (1) The belt type may cause vibration or noise during low-speed operation, so set the moving speed to 100mm/s or more.
- (2) The actuator specifications display the payload's maximum value. Please refer to "Table of Payload by Speed/ Acceleration" for more details.
- (3) Push-motion operation cannot be performed.
- (4) Special attention needs to be paid to the mounting orientation.
- (5) Reference value of the overhang load length is under 220mm in the Ma, Mb and Mc directions.
- (6) The center of gravity of the attached object should be less than 1/2 of the overhand distance. Even when the overhang distance and load moment are within the allowable range, the operating conditions should be moderated if some abnormal vibration or noise is observed.

Main Specifications

Item		Description	
Horizontal	Payload	Maximum payload (energy-saving disabled) (kg)	11
		Maximum payload (energy-saving enabled) (kg)	3
	Speed/acceleration/deceleration	Max. speed (mm/s)	1500
		Min. speed (mm/s)	100
		Rated acceleration/deceleration (G)	0.3
Brake	Max. acceleration/deceleration (G)	1.0	
	Brake holding specification	Non-excitation actuating solenoid brake	
Stroke	Brake holding force (kgf)	1.3	
	Min. stroke (mm)	300	
	Max. stroke (mm)	2600	
	Stroke pitch (mm)	100	

Item	Description
Driving system	Timing belt 9mm width 3mm pitch 48mm lead
Positioning repeatability	±0.08mm
Base	Dedicated aluminum extruded material (A6063SS-T5 Equivalent) Black alumite treatment
Linear guide	Linear motion infinite circulating type
Static allowable moment	Ma: 48 N·m
	Mb: 69 N·m
	Mc: 97 N·m
Dynamic allowable moment (Note 1)	Ma: 11 N·m
	Mb: 16 N·m
	Mc: 23 N·m
Ambient operation temperature/humidity	0~40°C, 85%RH or less (Non-condensing)
Degree of protection	IP20
Vibration & shock resistance	4.9m/s ²
Overseas standards	CE marking, RoHS (Restriction of Hazardous Substances)
Motor type	Pulse motor
Encoder type	Incremental / battery-less absolute
Number of encoder pulses	800 pulse/rev

■ Direction of moment for the Slider type

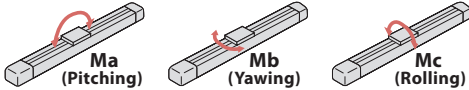

(Note 1) Based on the standard rated operation life of 5000 km. Operation life varies according to operating and mounting conditions.

Table of Payload by Speed and Acceleration/Deceleration

■ Energy-saving disabled The unit for payload is kg.

Orientation	Horizontal			
	Acceleration (G)			
Speed (mm/s)	0.3	0.5	0.7	1
0	11	10	8	7
200	11	10	8	7
300	11	8.5	7	6
600	7	5	4	3
1000	4	3	2	1
1200	3	2	1	0.5
1400	2	1	1	0.5
1500	2	1	1	0.5

■ Energy-saving enabled The unit for payload is kg.

Orientation	Horizontal	
	Acceleration (G)	
Speed (mm/s)	0.3	0.7
0	3	2
800	3	2
1400	0.5	0.5

Stroke and maximum speed

Energy saving	300 (mm)	400 (mm)	500 (mm)	600 (mm)	700 (mm)	800 (mm)	900~2600 (per 100mm)
Disabled	890	1070	1220	1340	1400	1440	1500
Enabled	890	1070	1220	1300	1350	1400	

(Unit is mm/s)

Dimensions

CAD drawings can be downloaded from our website.
www.elecylinder.de



ST: Stroke
M.E.: Mechanical end
S.E.: Stroke end

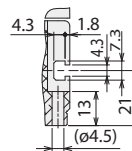
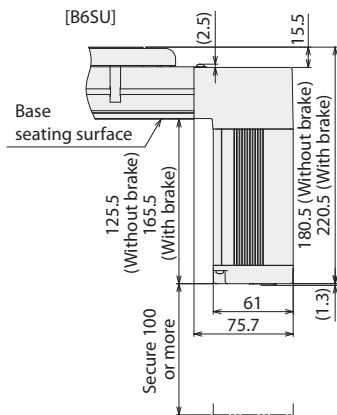
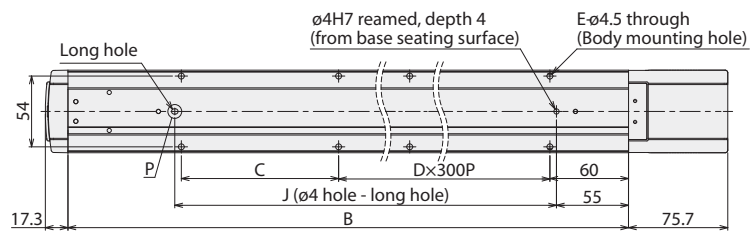
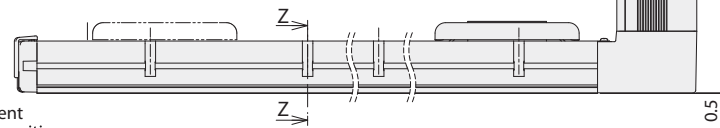
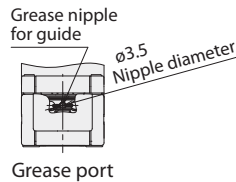
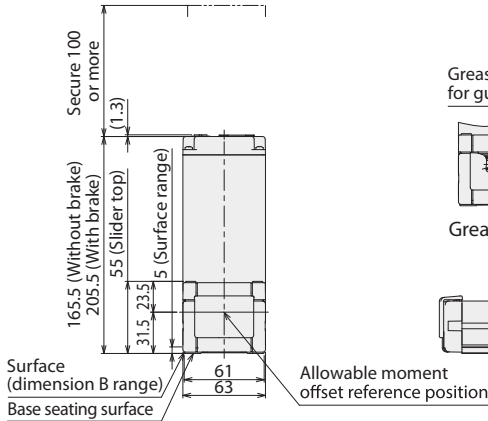
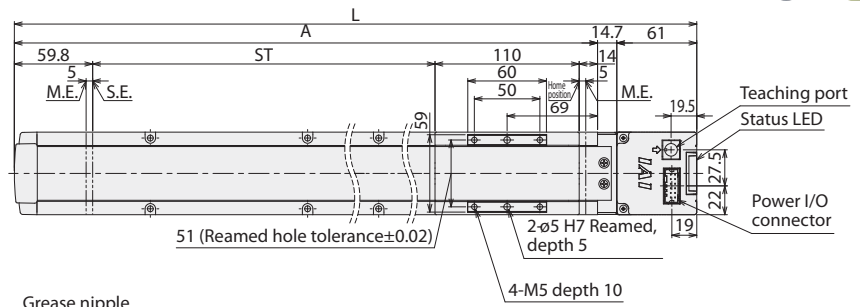

Sectional view Z-Z
Detail of through hole
for attaching the base
Base mounting hole
Details of T slot



Detailed drawing P
base long hole detail

■ Dimensions by stroke

Stroke	300	400	500	600	700	800	900	1000	1100	1200	1300	1400	1500	1600	1700	1800	1900	2000	2100	2200	2300	2400	2500	2600
L	559.5	659.5	759.5	859.5	959.5	1059.5	1159.5	1259.5	1359.5	1459.5	1559.5	1659.5	1759.5	1859.5	1959.5	2059.5	2159.5	2259.5	2359.5	2459.5	2559.5	2659.5	2759.5	2859.5
A	483.8	583.8	683.8	783.8	883.8	983.8	1083.8	1183.8	1283.8	1383.8	1483.8	1583.8	1683.8	1783.8	1883.8	1983.8	2083.8	2183.8	2283.8	2383.8	2483.8	2583.8	2683.8	2783.8
B	466.5	566.5	666.5	766.5	866.5	966.5	1066.5	1166.5	1266.5	1366.5	1466.5	1566.5	1666.5	1766.5	1866.5	1966.5	2066.5	2166.5	2266.5	2366.5	2466.5	2566.5	2666.5	2766.5
C	320	120	220	320	120	220	320	120	220	320	120	220	320	120	220	320	120	220	320	120	220	320	120	220
D	0	1	1	1	2	2	2	3	3	3	4	4	4	5	5	5	6	6	6	7	7	7	8	8
E	4	6	6	6	8	8	8	10	10	10	12	12	12	14	14	14	16	16	16	18	18	18	20	20
J	330	430	530	630	730	830	930	1030	1130	1230	1330	1430	1530	1630	1730	1830	1930	2030	2130	2230	2330	2430	2530	2630

■ Mass by stroke

Weight (kg)	Stroke	300	400	500	600	700	800	900	1000	1100	1200	1300	1400	1500	1600	1700	1800	1900	2000	2100	2200	2300	2400	2500	2600
	W/o Brake	2.7	3.0	3.4	3.7	4.0	4.3	4.7	5.0	5.3	5.6	5.9	6.3	6.6	6.9	7.2	7.5	7.8	8.2	8.5	8.8	9.2	9.5	9.8	10.2
With Brake	3.0	3.3	3.7	4.0	4.3	4.6	5.0	5.3	5.6	5.9	6.2	6.6	6.9	7.2	7.5	7.8	8.1	8.5	8.8	9.1	9.5	9.8	10.1	10.5	

Note: B6SU also has the same mass.

Applicable controller

(Note) The EC series is equipped with a built-in controller.

EC-B7S

EC-B7SU

Simple Dust Proof Belt Type Motor Unit Coupled Body width 73 mm 24v Pulse motor

■ Model Specification Items

EC - B7 S [] - [] - [] - []

Series	Type	Lead	Blank	Specification	Stroke	Cable Length	Option	
	S	48mm	Blank	Motor top-mounted	300 ? 2600	300mm ? 2600mm (100mm increments)	0 1 ? 10	Terminal type with connector 1m ? 10m
			U	Motor bottom-mounted			Refer to option below	

CE RoHS

Horizontal Vertical

Side Ceiling



(Note) The above is motor top-mounted type.

Cable Length

Cable code	Cable length
0	Without cable (with connector)
1 ~ 3	1 ~ 3m
4 ~ 5	4 ~ 5m
6 ~ 10	6 ~ 10m

Option

Name	Option code	Reference page
Brake	B	10
Specified grease applied specification*	G5	10
Non-motor end specification	NM	10
PNP specification	PN	10
Twin power supply specification	TMD2	10
Battery-less absolute encoder specification	WA	10
Wireless communication specification	WL	10
Wireless axis operation specification	WL2	10

*Change grease to food grade.

- POINT**
Selection Notes
- (1) The belt type may cause vibration or noise during low-speed operation, so set the moving speed to 100mm/s or more.
 - (2) The actuator specifications display the payload's maximum value. Please refer to "Table of Payload by Speed/ Acceleration" for more details.
 - (3) Push-motion operation cannot be performed.
 - (4) Special attention needs to be paid to the mounting orientation.
 - (5) Reference value of the overhang load length is under 280mm in the Ma, Mb and Mc directions.
 - (6) The center of gravity of the attached object should be less than 1/2 of the overhand distance. Even when the overhang distance and load moment are within the allowable range, the operating conditions should be moderated if some abnormal vibration or noise is observed.

Main Specifications

Item		Description	
Horizontal	Payload	Maximum payload (energy-saving disabled) (kg)	20
		Maximum payload (energy-saving enabled) (kg)	14
	Speed/acceleration/deceleration	Max. speed (mm/s)	1600
		Min. speed (mm/s)	100
		Rated acceleration/deceleration (G)	0.3
Brake	Max. acceleration/deceleration (G)	1.0	
	Brake holding specification	Non-excitation actuating solenoid brake	
Stroke	Brake holding force (kgf)	2.5	
	Min. stroke (mm)	300	
	Max. stroke (mm)	2600	
	Stroke pitch (mm)	100	

Item	Description
Driving system	Timing belt 9mm width 3mm pitch 48mm lead
Positioning repeatability	±0.08mm
Base	Dedicated aluminum extruded material (A6063SS-T5 Equivalent) Black alumite treatment
Linear guide	Linear motion infinite circulating type
Static allowable moment	Ma: 79 N·m
	Mb: 114 N·m
	Mc: 157 N·m
Dynamic allowable moment (Note 1)	Ma: 17 N·m
	Mb: 25 N·m
	Mc: 34 N·m
Ambient operation temperature/humidity	0~40°C, 85%RH or less (Non-condensing)
Degree of protection	IP20
Vibration & shock resistance	4.9m/s ²
Overseas standards	CE marking, RoHS (Restriction of Hazardous Substances)
Motor type	Pulse motor
Encoder type	Incremental / battery-less absolute
Number of encoder pulses	800 pulse/rev

Direction of moment for the Slider type

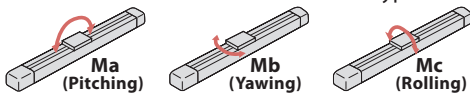

(Note 1) Based on the standard rated operation life of 5000 km. Operation life varies according to operating and mounting conditions.

Table of Payload by Speed and Acceleration/Deceleration

Energy-saving disabled The unit for payload is kg.

Orientation	Horizontal			
	Acceleration (G)			
Speed (mm/s)	0.3	0.5	0.7	1
0	20	20	18	16
100	20	20	18	16
200	20	20	17	15
300	19	17	15	13
600	11	9	8	7
1000	6	5	4	3
1400	3	2	1	0.5
1600	3	2	1	0.5

Energy-saving enabled The unit for payload is kg.

Orientation	Horizontal	
	Acceleration (G)	
Speed (mm/s)	0.3	0.7
0	14	12
100	14	12
400	10	8
800	5	3
1200	1	0.5

Stroke and maximum speed

Energy saving	300 (mm)	400 (mm)	500 (mm)	600 (mm)	700 (mm)	800 (mm)	900 (mm)	1000~2600 (per 100mm)
Disabled	890	1070	1220	1340	1450	1520	1550	1600
Enabled	890	1070	1120	1200				

(Unit is mm/s)

ST: Stroke
M.E.: Mechanical end
S.E.: Stroke end

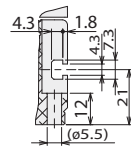
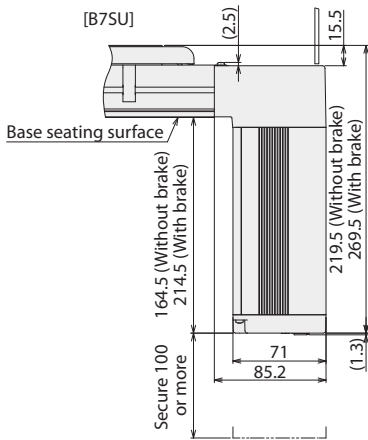
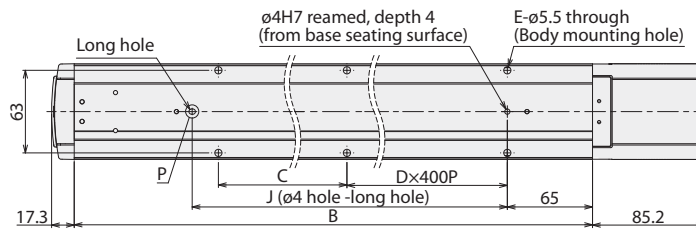
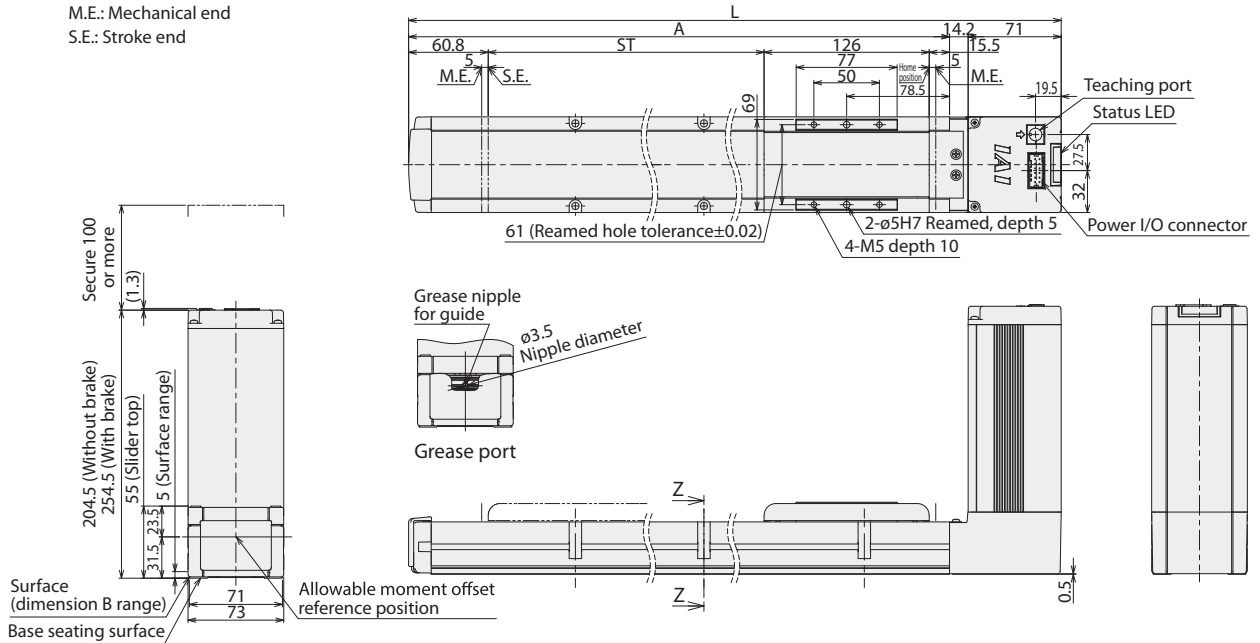

Sectional view Z-Z
Detail of through hole for attaching the base
Base mounting hole
Details of T slot



Detailed drawing P
base long hole detail

■ Dimensions by stroke

Stroke	300	400	500	600	700	800	900	1000	1100	1200	1300	1400	1500	1600	1700	1800	1900	2000	2100	2200	2300	2400	2500	2600
L	587.5	687.5	787.5	887.5	987.5	1087.5	1187.5	1287.5	1387.5	1487.5	1587.5	1687.5	1787.5	1887.5	1987.5	2087.5	2187.5	2287.5	2387.5	2487.5	2587.5	2687.5	2787.5	2887.5
A	502.3	602.3	702.3	802.3	902.3	1002.3	1102.3	1202.3	1302.3	1402.3	1502.3	1602.3	1702.3	1802.3	1902.3	2002.3	2102.3	2202.3	2302.3	2402.3	2502.3	2602.3	2702.3	2802.3
B	485	585	685	785	885	985	1085	1185	1285	1385	1485	1585	1685	1785	1885	1985	2085	2185	2285	2385	2485	2585	2685	2785
C	310	410	110	210	310	410	110	210	310	410	110	210	310	410	110	210	310	410	110	210	310	410	110	210
D	0	0	1	1	1	1	2	2	2	2	3	3	3	3	4	4	4	4	5	5	5	5	6	6
E	4	4	6	6	6	6	8	8	8	8	10	10	10	10	12	12	12	12	14	14	14	14	16	16
J	330	430	530	630	730	830	930	1030	1130	1230	1330	1430	1530	1630	1730	1830	1930	2030	2130	2230	2330	2430	2530	2630

■ Mass by stroke

Weight (kg)	Stroke	300	400	500	600	700	800	900	1000	1100	1200	1300	1400	1500	1600	1700	1800	1900	2000	2100	2200	2300	2400	2500	2600
	W/o Brake	4.6	4.9	5.2	5.6	5.9	6.2	6.5	6.8	7.1	7.5	7.8	8.1	8.4	8.7	9.1	9.4	9.7	10.0	10.3	10.7	11.0	11.3	11.6	12.0
With Brake	5.1	5.4	5.7	6.1	6.4	6.7	7.0	7.3	7.6	8.0	8.3	8.6	8.9	9.2	9.6	9.9	10.2	10.5	10.8	11.2	11.5	11.8	12.1	12.5	

Note: B7SU also has the same mass.

Applicable controller

(Note) The EC series is equipped with a built-in controller.

Options for the EleCylinder series

Brake

Model B

Description This works as a holding mechanism that prevents the slider moving when the power or servo is turned off.

Specified grease applied specification

Model G5

Description The grease put on the ballscrew, linear guide, and rod, is changed to food grade grease (White Alcom).

Non-motor end specification

Model NM

Description Although the home position is usually located on the motor side, it can be reversed as an option according to the requirement of the facility layout.

PNP specification

Model PN

Description The EC series offers NPN specification input/output for connecting external devices as standard. Specifying this option changes input/output to PNP specification.

Split motor and controller power supply specification

Model TMD2

Description Optional item to supply motor power and control power separately. Please refer to P. 13 for wiring details.

Battery-less Absolute Encoder specification

Model WA

Description The EC series offers incremental encoder specification as standard. Specifying this option installs a built-in battery-less absolute encoder.

Wireless communication specification

Model WL

Description Optional item is for wireless communications. By specifying this option, wireless communications with the teaching pendant TB-03 become available.

Wireless axis-operation specifications

Model WL2

Description By specifying WL2, all the wireless operations of WL (adjusting the starting point, the end point, and the AVD) are available, and test operation of axis movements (moving to forward/backward ends, jogging, and inching) are also possible. However, using this function for automated operations is not possible. Alterations from WL to WL2, or vice versa cannot be made by customer. Please contact IAI for more details.

System Configuration

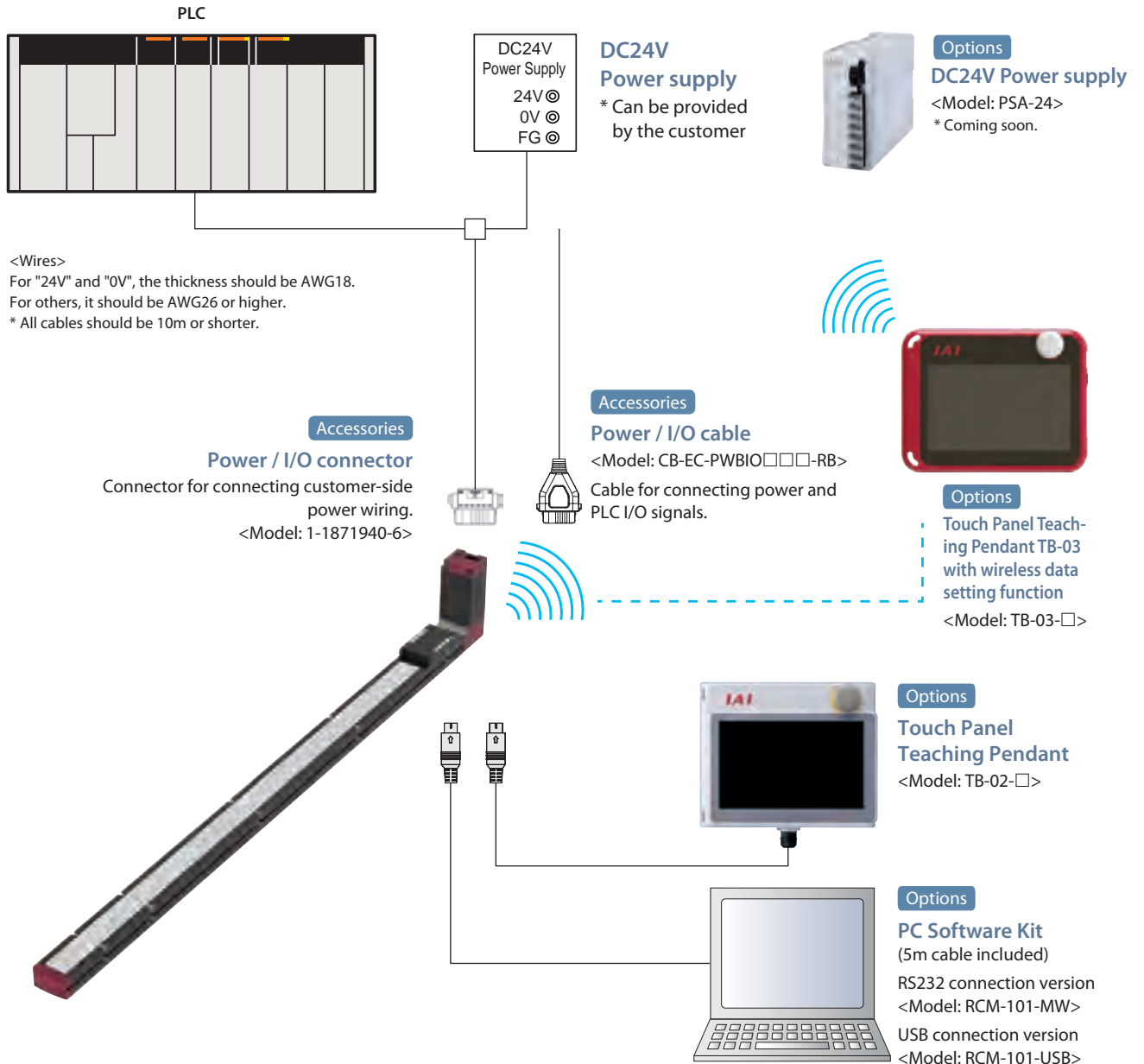

List of Accessories

Product category	Accessories
Without EC power / I/O cable (When cable length "0" is selected for actuator type)	Power / I/O connector (1-1871940-6)
With EC power / I/O cable (When cable length "1" to "10" is selected for actuator type)	Power / I/O cable (CB-EC-PWBIO□□□-RB)

Basic Controller Specifications

Specification item		Specification content	
Number of controlled axes		1 axis	
Power supply voltage		24VDC \pm 10%	
Power capacity	Standard	With energy-saving setting disabled: Rated 3.5A, Max. 4.2A With energy-saving setting enabled: Max. 2.2A	
Brake release power supply		24VDC \pm 10%, 200mA (only for external brake release)	
Generated heat		8W (at 100% duty)	
Inrush current (Note 1)	Standard	8.3A (with inrush current limit circuit)	
Momentary power failure resistance		Max. 500 μ s	
Motor size		\square 42, \square 56	
Motor rated current		1.2A	
Motor control system		Weak field-magnet vector control	
Supported encoders		Incremental (800 pulse/rev), battery-less absolute encoder (800 pulse/rev)	
SIO		RS485 1ch (Modbus protocol compliant)	
PIO	Input specification	No. of input	3 points (forward, backward, alarm clear)
		Input voltage	24VDC \pm 10%
		Input current	5mA per circuit
		Leakage current	Max. 1mA/1 point
	Output specification	Isolation method	Non-isolated
		No. of output	3 points (forward complete, backward complete, alarm)
		Output voltage	24VDC \pm 10%
		Output current	50mA/1 point
	Residual voltage	2V or less	
	Isolation method	Non-isolated	
Data setting and input methods		Teaching software for PC, touch panel teaching pendant	
Data retention memory		Position and parameters are saved in non-volatile memory. (No limit to rewrite)	
LED display	Controller status display	Servo ON (green light ON) / Alarm (red light ON) / Initializing when power comes ON (orange light ON) / Minor failure alarm (green/red alternately blinking) / Operation from teaching: Stop from teaching (red light ON) / Servo OFF (light OFF)	
	Wireless status display	Initializing wireless hardware, without wireless connection, or connecting from TP board (light OFF) Connecting through wireless (green blinking) / Wireless hardware error (red blinking) / Initializing when power comes ON (orange light ON)	
Predictive maintenance/Preventative maintenance		When the number of movements or operation distance has exceeded the set value and when the LED (right side) blinks alternately green and red at overload warning * Only when configured in advance	
Ambient operating temperature		0 to 40°C	
Ambient operating humidity		85% RH or less (no condensation or freezing)	
Operating ambience		Avoid corrosive gas and excessive dust	
Insulation resistance		500VDC 10M Ω	
Electric shock protection mechanism		Class 1 basic insulation	
Cooling method		Natural air cooling	

(Note 1) Inrush current flows for approximately 5ms after the power is input (At 40°C). Inrush current value differs depending on the impedance on the power supply line.

I/O Specification (Input/Output specifications)

I/O		Input		Output	
Specifications		Input voltage	DC24V±10%	Load voltage	DC24V±10%
		Input current	5mA/circuit	Max. load current	50mA/point
		ON/OFF Voltage	ON voltage MIN DC18V OFF voltage MAX DC6V	Residual voltage	2V or less
		Leak current	MAX 1mA/point	Leak current	MAX 0.1mA/point
Insulation method		Not isolated from external circuit		Not isolated from external circuit	
I/O logic	NPN				
	PNP				

(Note) Isolation method is non-isolated. When connecting an external device (such as a PLC) to EleCylinder, use the same ground as EleCylinder.

I/O Specification Wiring Diagram

I/O		Standard Specification	TMD2 Specification (Option)
Power • I/O connector		<p>0V A1 (Spare) A2 Backward complete A3 Forward complete A4 Alarm output A5 (Spare) A6</p> <p>B1 24V B2 Brake release B3 Backward command B4 Forward command B5 Alarm release B6 (Spare)</p>	<p>The TMD2 specification is a specification in which the motor power and control power are separated.</p> <p>0V A1 24V(Control) A2 Backward complete A3 Forward complete A4 Alarm output A5 (Spare) A6</p> <p>B1 24V(Drive) B2 Brake release B3 Backward command B4 Forward command B5 Alarm release B6 (Spare)</p>
I/O logic	NPN		
	PNP		

I/O Signal Table

Power / I/O connector pin assignment			
Pin No.	Connector nameplate name	Signal abbreviation	Function overview
B3	Backward	ST0	Backward command
B4	Forward	ST1	Forward command
B5	Alarm cancel	RES	Alarm cancel
A3	Backward complete	LS0/PE0	Backward complete/push complete
A4	Forward complete	LS1/PE1	Forward complete/push complete
A5	Alarm	* ALM	Alarm detection (b-contact)
B2	Brake release	BKRLS	Brake forced release (for brake equipped specification)
B1 (Note)	24V	24V	24V input
A1	0V	0V	0V input
A2 (Note)	(24V)	(24V)	24V input

(Note) For the twin power supply specification (TMD2), B1 is 24V (drive) and A2 is 24V (control).

Options

Touch Panel Teaching Pendant

■ **Features** A teaching device equipped with functions such as position teaching, trial operation, and monitoring.

■ **Model** TB-02-□ Please contact IAI for the current supported versions.

■ **Configuration** Wired connection

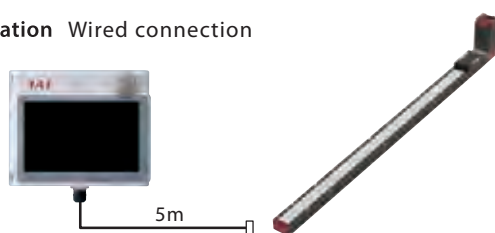

■ Specifications

Rated voltage	24VDC
Power consumption	3.6W or less (150mA or less)
Ambient operating temperature	0 to 40°C
Ambient operating humidity	20 to 85% RH (Non-condensing)
Environmental resistance	IP20
Mass	470g (TB-02 unit only)

Touch Panel Teaching Pendant with Wireless Function

■ **Features** A teaching device that supports wireless connection. Start point/end point/AVD input and axis operation can be performed with wireless connection for WL option. Manual operation is wirelessly possible for WL2 option.

■ **Model** TB-03-□ Please contact IAI for the current supported versions.

■ **Configuration** Wireless or wired connection

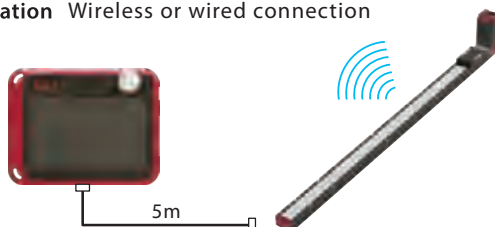

■ Specifications

Rated voltage	24VDC
Power consumption	3.6W or less (150mA or less)
Ambient operating temperature	0 to 40°C
Ambient operating humidity	20 to 85% RH (Non-condensing)
Environmental resistance	IPX0
Mass	Approx. 485g (body) + approx. 175g (battery)
Charging method	Wired connection with dedicated adapter/controller
Wireless connection	Bluetooth 4.2 class2

Options

Teaching software for PC (Windows only)

- **Features** The start-up support software comes equipped with functions such as position teaching, trial operation, and monitoring.
A complete range of functions needed for making adjustments contributes to shortened start-up time.

Supported Windows versions: 7/8/10

- **Model RCM-101-MW** (with an external device communication cable + RS232 conversion unit) Please contact IAI for the current supported versions.

■ **Configuration**

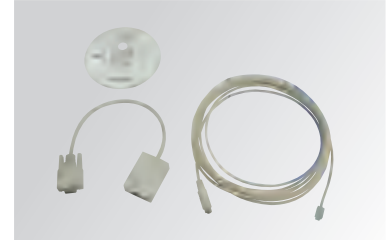
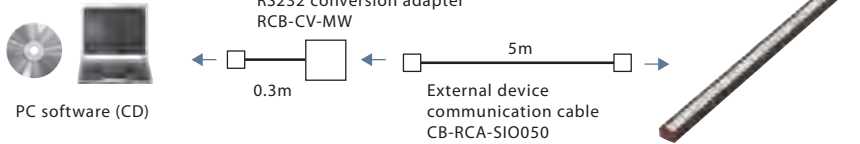

- **Model RCM-101-USB** (with an external device communication cable + USB conversion adapter + USB cable) Please contact IAI for the current supported versions.

■ **Configuration**

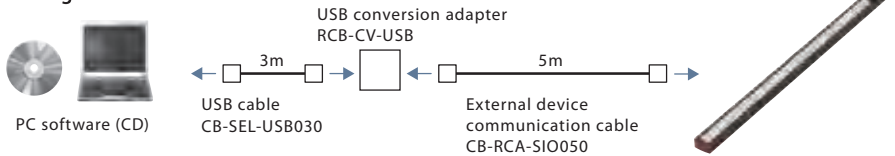

Maintenance Parts

When placing an order for a replacement cable, please use the model name shown below.

■ **Table of compatible cables**

Model name	Power / I/O cable
EC	CB-EC-PWBIO□□□-RB

Model **CB-EC-PWBIO□□□-RB**

* Please indicate the cable length (L) in □□□, E.g.) 030 = 3m

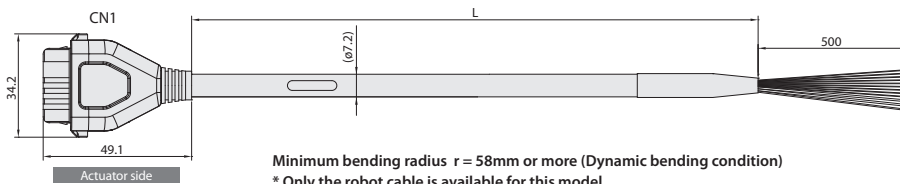

Minimum bending radius $r = 58\text{mm}$ or more (Dynamic bending condition)
* Only the robot cable is available for this model.

Color	Signal name	Pin No.
Black (AWG18)	0V	A1
Red (AWG18)	24V	B1
Light blue (AWG22)	(Reserved) (Note 1)	A2
Orange (AWG26)	IN0	B3
Yellow (AWG26)	IN1	B4
Green (AWG26)	IN2	B5
Pink (AWG26)	(reserve)	B6
Blue (AWG26)	OUT0	A3
Purple (AWG26)	OUT1	A4
Gray (AWG26)	OUT2	A5
White (AWG26)	(reserve)	A6
Brown (AWG26)	BKRLS	B2

(Note 1) 24V (control) when twin power supply specification (TMD2) selected.