

8-Axis Program Controller

X-SEL RA(X)/SA(X)



A single controller can operate up to 40 axes. Greater capacity as compared with the conventional XSEL controller

1

■ Corresponds to actuators with built-in battery-less absolute encoders as standard.

Corresponds to actuators with built-in battery-less absolute encoders as standard. No battery maintenance is required since there is no battery. Since home-return operation is not required at start up or after emergency stop or malfunction, this reduces your operation time, resulting in reduced production costs.

The advantages of battery-less

1. Periodic replacement of the battery is not required.
2. No installation space for battery required.
3. Battery-related errors do not occur.



Battery-less Absolute Encoder

No Battery, No Maintenance,
No Homing, and No Price Increase.
No Going Back to Incremental.



2

■ Shortening of program processing time

The processing capacity has been enhanced due to the improved performance of on-board CPU. This increases the SEL language instruction processing speed, which allows the program processing time to be shortened.

(Example)

Instruction words	Controller	Instruction processing time (ms)
Division instruction DIV (Local integer)	Conventional models	
	RA/SA	Approx. 1/15 reduced
Output processing instruction BTON	Conventional models	
	RA/SA	Approx. 1/5 reduced

3

■ Improved functions

The data capacity has been significantly expanded as compared with the conventional XSEL controller.

	RA/SA		P/Q
No. of programs	255	2 times	128
No. of steps	20000	2 times	9999
No. of position data	25384 (8-axis)	1.3 times	20000 (6-axis)

More advanced XSEL-RA/SA is now available!

4

Compliant with Ethernet/USB as standard

Equipped with Ethernet and USB port as the PC software interface and general message communication interface.

	Controller side connector	Communication speed
Ethernet	10/100/1000BASE-T (RJ-45)	10/100/1000Mbps
USB	USB2.0 (Mini-B)	480Mbps (High speed) 12Mbps (Full speed)

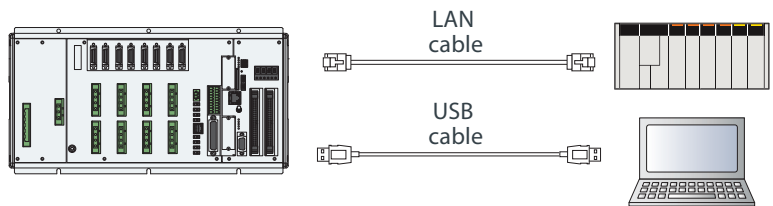

5

Expanded motion control

Up to 32 axes of IAI position controller with MECHATROLINK III can be connected to perform program control using the XSEL controller.

[Connectable controllers: PCON-CB, ACON-CB, DCON-CB, SCON-CB, MCON, MECHATROLINK III specifications]

Up to 40 axes can be operated and controlled using a single controller in combination with up to 8 connected axes of the XSEL controller. Capable of operating at the positioner function and synchronization control function (*).

* The SCARA robot controller cannot use the synchronization control function.

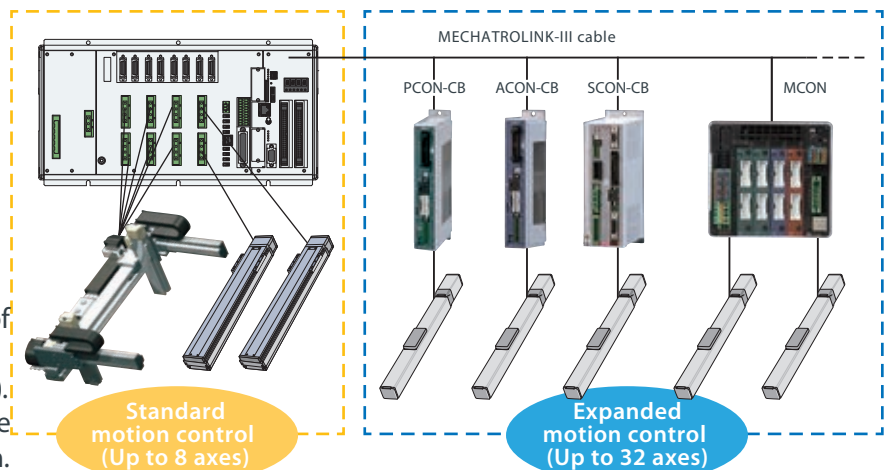

6

External equipment can be controlled easily

Output operation data field has been added to the positioning data. Signals for controlling external equipment can be easily output for each target position. This eliminates the conventionally required time to create a program to send the signal.

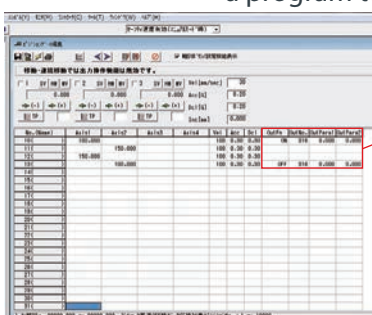

Sl	OutFn	OutNo.	OutPara1	OutPara2
-30	ON	316	0.000	0.000
-30				
-30	OFF	316	0.000	0.000

Output operation data item

7

Extensive network compatible

Option

"DeviceNet", "CC-Link" or "PROFIBUS" can be used simultaneously with "EtherNet/IP (*)" or "EtherCAT".

* Capable of Ethernet communication.





X-SEL

Program Controller for Single-axis Robot, Cartesian Robot, Direct Drive Motor, RCS3/RCS2 Series and SCARA Robot



List of Models

Multi-axis program controller that can operate servo motor type actuators. Allows simultaneous control of up to 8 axes.

Type Name	RA	SA
Name	High-function type	High-function type (Safety category compatible type)
External view		
Type	Standard specification	Safety category specification
Max. no. of connected axes	8 axes	
No. of programs	255 points	
No. of program steps	20000 steps	
No. of positions (*1)	1-axis: 55000; 2-axis: 47142; 3-axis: 41250; 4-axis: 36666; 5-axis: 33000; 6-axis: 30000; 7-axis: 27500; 8-axis: 25384	
Total no. of connectable W (*2)	Single-phase 1600W/Three-phase 2400W	
Motor power	Single-phase 230VAC/Three-phase 230VAC	
Control power supply	Single-phase 200VAC	
Safety category (*3)	B	Safety category 4 compatible
Safety standard	CE compliant	

(*1) The number of positions varies by the number of axes supported by the controller.

(*2) In vertical motion, the maximum output per axis will be limited to under 600W.

(*3) To comply to the safety category, the customer will need to install a safety circuit outside the controller.

Type Name	RAX	SAX	RAXD8	SAXD8
Name	SCARA 1-unit, single-axis and cartesian specification		SCARA 2-unit specification	
External view				
Type	Standard specification	Safety category specification	Standard specification	Safety category specification
Max. no. of connected axes	8 axes			
No. of programs	255 points			
No. of program steps	20000 steps			
No. of positions (*1)	4-axis: 36666; 5-axis: 33000; 6-axis: 30000; 7-axis: 27500; 8-axis: 25384			
Total no. of connectable W (*2)	Three-phase 2400W			
Motor power	Three-phase 230VAC			
Control power supply	Single-phase 230VAC			
Safety category (*3)	B	Safety category 4 compatible	B	Safety category 4 compatible
Safety standard	CE compliant			

(*1) The number of positions varies by the number of axes supported by the controller.

(*2) In vertical motion, the maximum output per axis will be limited to under 600W.

(*3) To comply to the safety category, the customer will need to install a safety circuit outside the controller.

Model

Single-axis and cartesian specifications XSEL-RA/SA type

Note: When selecting more than one option, please write in alphabetical order. (Example: brake + home sensor -> BL)

(Details of the 1st axis) (Details of the 2nd~8th axis)

XSEL - [] - [] - [] - [] - [] - [] - [] - [] - [] - [] - [] - []

Series Type Number of Connected Axes Motor Type Encoder Type Options Motor Type Encoder Type Options Network Dedicated Slots (Slot 1) (Slot 2) I/O Slots (Slot 1) (Slot 2) I/O Cable Length Power Supply Voltage

RA	Standard specification															
SA	Safety category specification															

1	1-axis	5	5-axis
2	2-axis	6	6-axis
3	3-axis	7	7-axis
4	4-axis	8	8-axis

12	12W servo motor	150	150W servo motor
20	20W servo motor	200	200W servo motor
30D	30W servo motor for RCS2	200S	For LSAS-N15
30R	30W servo motor for RS	400	400W servo motor
60	60W servo motor	600	600W servo motor
100	100W servo motor	750	750W servo motor
100S	For LSAS-N10		

WAI	Battery-less abs. Incremental
A	Absolute
G	Quasi absolute
AI	Index absolute
AM	Multi-rotation abs.

E	Not used	E	Not used
EP	EtherNet/IP	DV	DeviceNet
EC	EtherCAT	CC	CC-Link
		PR	PROFIBUS-DP

0	No cable
2	2m (Standard)
3	3m
5	5m

2	Single-phase 230V
2L	Dedicated linear single-phase 230V
3	Three-phase 230V
3L	Dedicated linear three-phase 230V

B	Brake equipped specification	P1	Input 32/Output 16 (PNP)
C	Creep sensor specification	P2	Input 16/Output 32 (PNP)
HA	Hi-accel./decel. specification	P3	Input 48/Output 48 (PNP)
L	Home sensor/LS compatible		
M	Master axis specified		
S	Slave axis specified		

E	Not used	N1	Input 32/Output 16 (NPN)
N1	Input 32/Output 16 (NPN)	N2	Input 16/Output 32 (NPN)
N2	Input 16/Output 32 (NPN)	N3	Input 48/Output 48 (NPN)
N3	Input 48/Output 48 (NPN)		

(* Selectable boards are fixed for the network dedicated slot. Select one among the options and enter symbol.
 (* The network dedicated slot and I/O slot can be used together.)

(* 2L/3L is selected when LSAS is connected

* Notes when single-axis robot and cartesian robot are selected
 The total wattage of the single-axis robot and cartesian robot that can be connected to XSEL-RA/SA is 2400W for the three-phase specification and 1600W for the single-phase specification.
 Although the maximum wattage per axis is 750W, please make sure that the total wattage of each axis does not exceed the specified wattage.

Actuators that cannot be connected

Please note that the following models cannot be operated with XSEL-RA/SA.

- RCS2-SRA7/SRG57/SRGD7 Series · RCS3-CTZ5C/CT8C
- RCS2-RA13R (With load cell) · RCS3-RA4R/RA6R/RA7R/RA8R/RA10R/RA15R/RA20R
- Incremental types of following models
 RCS2-□□5N Series NS-SXM□/SZM□

*LSAS series w/o CE conformity.

The maximum connectable actuators when connecting LSAS* (linear motor)

When connecting the LSAS* series to the single-phase specification, please calculate the total wattage based on the "Output value for controller wattage calculation" in the table below.
 In addition, make sure that the total wattage of LSAS* and actuators other than LSAS* is equal to or less than 1600W.

LSAS* motor wattage conversion table in single-phase specification

Actuator type	Applicable driver output [W]	No. of sliders [pcs]	Output value for controller wattage calculation [W]
N10SS	100	1	300
N10SM	100	2	600
N15SS	200	1	600
N15SM	200	2	1200
N15HS	200	1	600
N15HM	200	2	1200

The maximum connectable actuators when connecting direct drive motor

When connecting the DD/DDA motor series, please calculate the total wattage based on the "Output value for controller wattage calculation" in the table below and make sure it does not exceed the maximum number of connected units.
 In addition, make sure that the total wattage of DD/DDA Series and actuators other than DD/DDA Series is equal to or less than 1600W.

DD/DDA motor wattage conversion table in single-phase specification connection

Actuator type	Applicable driver output [W]	Max. no. of connected units of DD/DDA motor [unit]	Output value for controller wattage calculation [W]
T18S/T18CS	200	2	600
LT18S/LT18CS	200	2	600
H18S/H18CS	600	1	1200
LH18S/LH18CS	600	1	1200

DD/DDA motor wattage conversion table in three-phase specification connection

Actuator type	Applicable driver output [W]	Max. no. of connected units of DD/DDA motor [unit]	Output value for controller wattage calculation [W]
T18S/T18CS	200	8	200
LT18S/LT18CS	200	8	200
H18S/H18CS	600	2	600
LH18S/LH18CS	600	2	600

System Configuration

■ XSEL-RA/SA Type

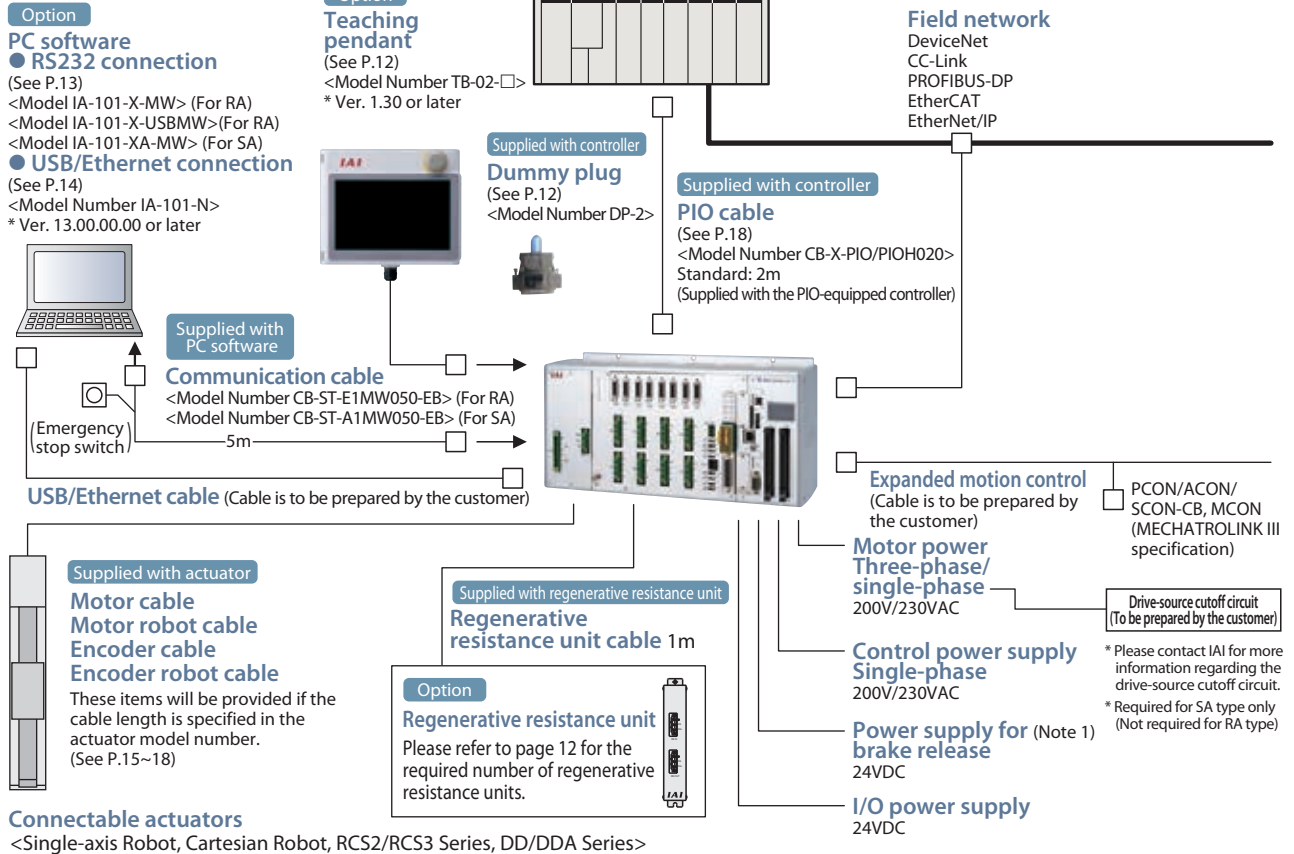

■ XSEL-RAX/RAXD/SAX/SAXD Type

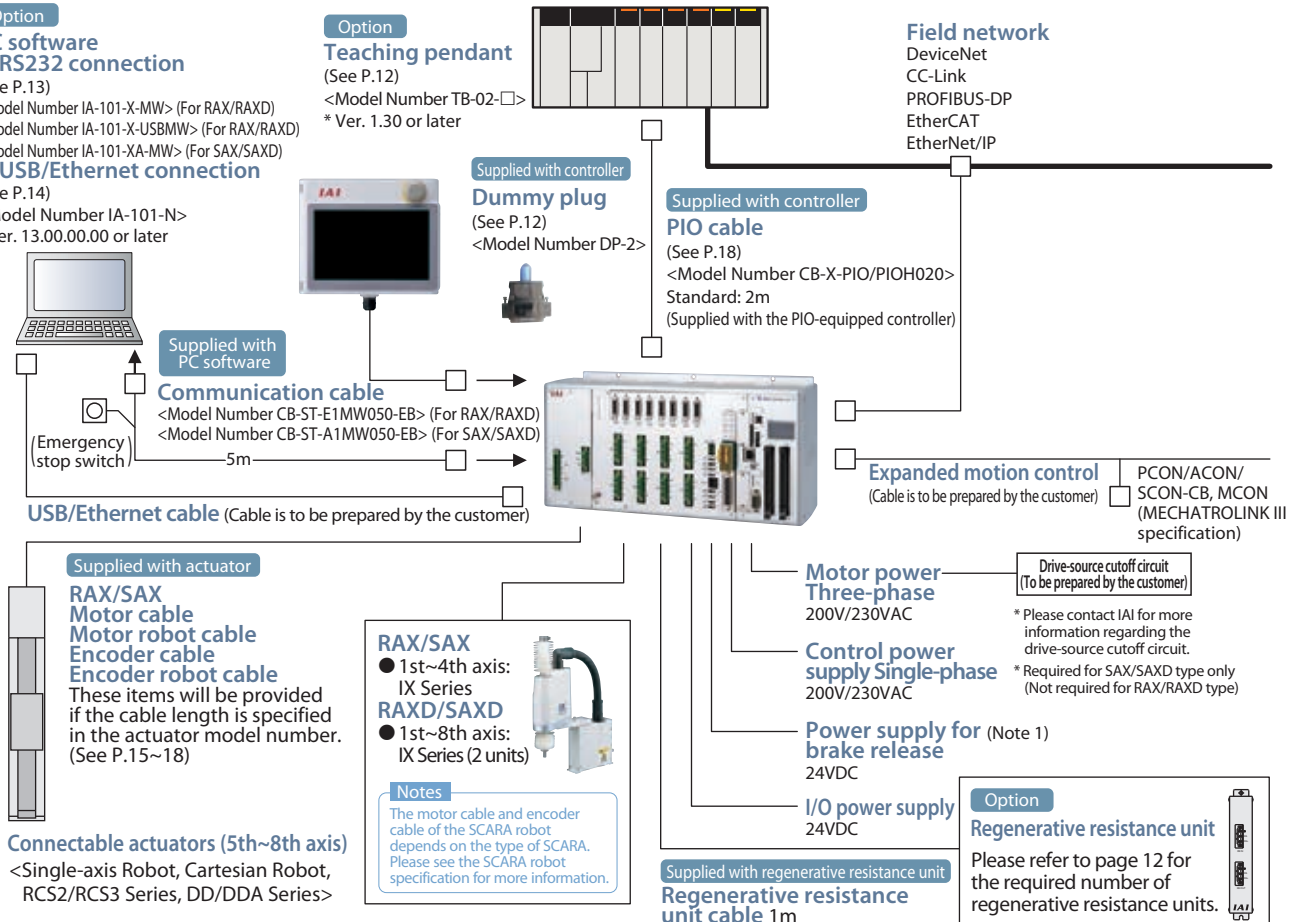

(Note 1) When connecting an actuator with brake, the brake power supply +24V is required.

I/O Wiring Diagram

Input External input specification (NPN specification)

Item	Specification
Input voltage	24VDC ± 10%
Input current	7mA, 1 circuit
ON/OFF voltage	ON voltage: min. 16.0VDC; OFF voltage: max. 5.0VDC
Isolation method	Photocoupler isolation

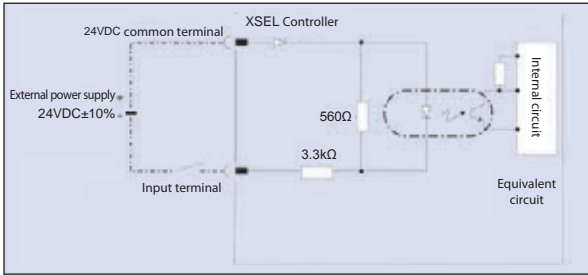

Input External input specification (PNP specification)

Item	Specification
Input voltage	24VDC ± 10%
Input current	7mA, 1 circuit
ON/OFF voltage	ON voltage: min. 8VDC; OFF voltage: max. 19VDC
Isolation method	Photocoupler isolation

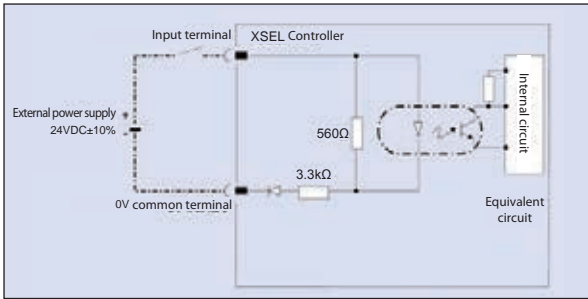

Output External output specification (NPN specification)

Item	Specification
Load voltage	24VDC
Maximum load current	100mA/1 point 400mA/8 ports. (Note)
Leakage current	Max. 0.1mA/1 contact
Isolation method	Photocoupler isolation

TD62084 (equivalent) used

Note: The maximum load current will be 400mA per 8 ports from the output port No.300. (The maximum load current between the output port No.300 + n and No.300 + n + 7 is 400mA. n = 0 or multiple of 8.)

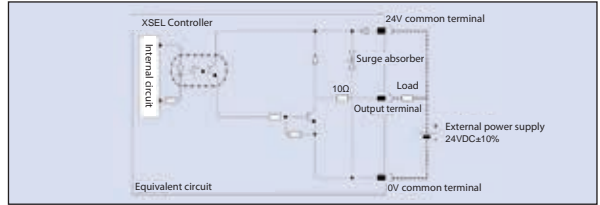

Output External output specification (PNP specification)

Item	Specification
Load voltage	24VDC
Maximum load current	100mA/1 point 400mA/8 ports. (Note)
Leakage current	Max. 0.1mA/1 contact
Isolation method	Photocoupler isolation

TD62784 (equivalent) used

Note: The maximum load current will be 400mA per 8 ports from the output port No.300. (The maximum load current between the output port No.300 + n and No.300 + n + 7 is 400mA. n = 0 or multiple of 8.)

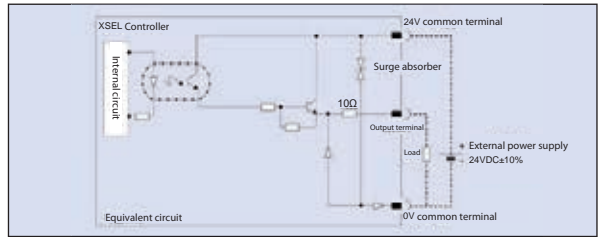

I/O Signal Table

Standard I/O signal table (When N1 or P1 is selected)

Pin No.	Category	Port No.	Standard setting
1		-	24V connection
2		000	Program start
3		001	General-purpose input
4		002	General-purpose input
5		003	General-purpose input
6		004	General-purpose input
7		005	General-purpose input
8		006	General-purpose input
9		007	Program No. (PRG No.1)
10		008	Program No. (PRG No.2)
11		009	Program No. (PRG No.4)
12		010	Program No. (PRG No.8)
13		011	Program No. (PRG No.10)
14		012	Program No. (PRG No.20)
15		013	Program No. (PRG No.40)
16		014	General-purpose input
17	Input	015	General-purpose input
18		016	General-purpose input
19		017	General-purpose input
20		018	General-purpose input
21		019	General-purpose input
22		020	General-purpose input
23		021	General-purpose input
24		022	General-purpose input
25		023	General-purpose input
26		024	General-purpose input
27		025	General-purpose input
28		026	General-purpose input
29		027	General-purpose input
30		028	General-purpose input
31		029	General-purpose input
32		030	General-purpose input
33		031	General-purpose input
34		300	Alarm output
35		301	Ready output
36		302	Emergency stop output
37		303	General-purpose output
38		304	General-purpose output
39		305	General-purpose output
40		306	General-purpose output
41		307	General-purpose output
42		308	General-purpose output
43		309	General-purpose output
44		310	General-purpose output
45		311	General-purpose output
46		312	General-purpose output
47		313	General-purpose output
48		314	General-purpose output
49		315	General-purpose output
50		-	0V connection

Expanded I/O signal table (When N1 or P1 is selected)

Pin No.	Category	Standard setting
1		24V connection
2		General-purpose input
3		General-purpose input
4		General-purpose input
5		General-purpose input
6		General-purpose input
7		General-purpose input
8		General-purpose input
9		General-purpose input
10		General-purpose input
11		General-purpose input
12		General-purpose input
13		General-purpose input
14		General-purpose input
15		General-purpose input
16		General-purpose input
17	Input	General-purpose input
18		General-purpose input
19		General-purpose input
20		General-purpose input
21		General-purpose input
22		General-purpose input
23		General-purpose input
24		General-purpose input
25		General-purpose input
26		General-purpose input
27		General-purpose input
28		General-purpose input
29		General-purpose input
30		General-purpose input
31		General-purpose input
32		General-purpose input
33		General-purpose input
34		General-purpose output
35		General-purpose output
36		General-purpose output
37		General-purpose output
38		General-purpose output
39		General-purpose output
40		General-purpose output
41		General-purpose output
42		General-purpose output
43		General-purpose output
44		General-purpose output
45		General-purpose output
46		General-purpose output
47		General-purpose output
48		General-purpose output
49		General-purpose output
50		0V connection

Expanded I/O signal table (When N2 or P2 is selected)

Pin No.	Category	Standard setting
1		24V connection
2		General-purpose input
3		General-purpose input
4		General-purpose input
5		General-purpose input
6		General-purpose input
7		General-purpose input
8		General-purpose input
9	Input	General-purpose input
10		General-purpose input
11		General-purpose input
12		General-purpose input
13		General-purpose input
14		General-purpose input
15		General-purpose input
16		General-purpose input
17		General-purpose input
18		General-purpose output
19		General-purpose output
20		General-purpose output
21		General-purpose output
22		General-purpose output
23		General-purpose output
24		General-purpose output
25		General-purpose output
26		General-purpose output
27		General-purpose output
28		General-purpose output
29		General-purpose output
30		General-purpose output
31		General-purpose output
32		General-purpose output
33		General-purpose output
34	Output	General-purpose output
35		General-purpose output
36		General-purpose output
37		General-purpose output
38		General-purpose output
39		General-purpose output
40		General-purpose output
41		General-purpose output
42		General-purpose output
43		General-purpose output
44		General-purpose output
45		General-purpose output
46		General-purpose output
47		General-purpose output
48		General-purpose output
49		General-purpose output
50		0V connection

Standard multi-point I/O signal table (When N3 or P3 is selected)

Pin No.	Category	Port No.	Standard setting
1	-	-	External power supply (24VDC) for the pin No. 2~25, 51~74
2		000	Program start
3		001	General-purpose input
4		002	General-purpose input
5		003	General-purpose input
6		004	General-purpose input
7		005	General-purpose input
8		006	General-purpose input
9		007	Program No. (PRG No.1)
10		008	Program No. (PRG No.2)
11		009	Program No. (PRG No.4)
12		010	Program No. (PRG No.8)
13	Input	011	Program No. (PRG No.10)
14		012	Program No. (PRG No.20)
15		013	Program No. (PRG No.40)
16		014	General-purpose input
17		015	General-purpose input
18		016	General-purpose input
19		017	General-purpose input
20		018	General-purpose input
21		019	General-purpose input
22		020	General-purpose input
23		021	General-purpose input
24		022	General-purpose input
25		023	General-purpose input
26	-	-	External power supply (24VDC) for the pin No. 27~50, 76~99
27		024	General-purpose input
28		025	General-purpose input
29		026	General-purpose input
30		027	General-purpose input
31		028	General-purpose input
32		029	General-purpose input
33		030	General-purpose input
34		031	General-purpose input
35		032	General-purpose input
36		033	General-purpose input
37		034	General-purpose input
38		035	General-purpose input
39	Input	036	General-purpose input
40		037	General-purpose input
41		038	General-purpose input
42		039	General-purpose input
43		040	General-purpose input
44		041	General-purpose input
45		042	General-purpose input
46		043	General-purpose input
47		044	General-purpose input
48		045	General-purpose input
49		046	General-purpose input
50		047	General-purpose input
51		300	Alarm output
52		301	Ready output
53		302	Emergency stop output
54		303	General-purpose output
55		304	General-purpose output
56		305	General-purpose output
57		306	General-purpose output
58		307	General-purpose output
59		308	General-purpose output
60		309	General-purpose output
61		310	General-purpose output
62	Output	311	General-purpose output
63		312	General-purpose output
64		313	General-purpose output
65		314	General-purpose output
66		315	General-purpose output
67		316	General-purpose output
68		317	General-purpose output
69		318	General-purpose output
70		319	General-purpose output
71		320	General-purpose output
72		321	General-purpose output
73		322	General-purpose output
74		323	General-purpose output
75	-	-	External power supply (0V) for the pin No. 2~25, 51~74
76		324	General-purpose output
77		325	General-purpose output
78		326	General-purpose output
79		327	General-purpose output
80		328	General-purpose output
81		329	General-purpose output
82		330	General-purpose output
83		331	General-purpose output
84		332	General-purpose output
85		333	General-purpose output
86		334	General-purpose output
87	Output	335	General-purpose output
88		336	General-purpose output
89		337	General-purpose output
90		338	General-purpose output
91		339	General-purpose output
92		340	General-purpose output
93		341	General-purpose output
94		342	General-purpose output
95		343	General-purpose output
96		344	General-purpose output
97		345	General-purpose output
98		346	General-purpose output
99		347	General-purpose output
100	-	-	External power supply (0V) for the pin No. 27~50, 76~99

Expanded multi-point I/O signal table (When N3 or P3 is selected)

Pin No.	Category	Port No.	Standard setting
1	-	-	External power supply (24VDC) for the pin No. 2~25, 51~74
2			General-purpose input
3			General-purpose input
4			General-purpose input
5			General-purpose input
6			General-purpose input
7			General-purpose input
8			General-purpose input
9			General-purpose input
10			General-purpose input
11			General-purpose input
12			General-purpose input
13	Input		General-purpose input
14			General-purpose input
15			General-purpose input
16			General-purpose input
17			General-purpose input
18			General-purpose input
19			General-purpose input
20			General-purpose input
21			General-purpose input
22			General-purpose input
23			General-purpose input
24			General-purpose input
25			General-purpose input
26	-	-	External power supply (24VDC) for the pin No. 27~50, 76~99
27			General-purpose input
28			General-purpose input
29			General-purpose input
30			General-purpose input
31			General-purpose input
32			General-purpose input
33			General-purpose input
34			General-purpose input
35			General-purpose input
36			General-purpose input
37			General-purpose input
38			General-purpose input
39	Input		General-purpose input
40			General-purpose input
41			General-purpose input
42			General-purpose input
43			General-purpose input
44			General-purpose input
45			General-purpose input
46			General-purpose input
47			General-purpose input
48			General-purpose input
49			General-purpose input
50			General-purpose input
51			General-purpose output
52			General-purpose output
53			General-purpose output
54			General-purpose output
55			General-purpose output
56			General-purpose output
57			General-purpose output
58			General-purpose output
59			General-purpose output
60			General-purpose output
61			General-purpose output
62	Output		General-purpose output
63			General-purpose output
64			General-purpose output
65			General-purpose output
66			General-purpose output
67			General-purpose output
68			General-purpose output
69			General-purpose output
70			General-purpose output
71			General-purpose output
72			General-purpose output
73			General-purpose output
74			General-purpose output
75	-	-	External power supply (0V) for the pin No. 2~25, 51~74
76			General-purpose output
77			General-purpose output
78			General-purpose output
79			General-purpose output
80			General-purpose output
81			General-purpose output
82			General-purpose output
83			General-purpose output
84			General-purpose output
85			General-purpose output
86			General-purpose output
87	Output		General-purpose output
88			General-purpose output
89			General-purpose output
90			General-purpose output
91			General-purpose output
92			General-purpose output
93			General-purpose output
94			General-purpose output
95			General-purpose output
96			General-purpose output
97			General-purpose output
98			General-purpose output
99			General-purpose output
100	-	-	External power supply (0V) for the pin No. 27~50, 76~99

Specification Table

Item		Description			
Controller type		RA	SA	RAX/RAXD	SAX/SAXD
Compatible motor output		20W~750W		12W~750W	
Number of controlled axes		1~8 axes		1~4 axes: SCARA robot 5~8 axes: 2nd SCARA robot or additional axes	
Max. output of connected axes		[Three-phase] Up to 2400W [Single-phase] Up to 1600W		[Three-phase] Up to 2400W	
Motor input power-supply voltage		[Three-phase] 200/230VAC ±10% [Single-phase] 200/230VAC ±10%		[Three-phase] 200/230VAC ±10%	
Control power input		Single-phase 200/230VAC ±10%			
Power frequency		50/60Hz			
Insulation resistance		Not less than 10MΩ (Between the power supply terminal and I/O terminal, and between the external terminal batch and case, at 500VDC)			
Insulation withstanding voltage		1500VAC (1 min)			
Power capacity (max)		5094VA (at max. output of connected axes)			
Position detection method		Incremental, absolute, battery-less absolute			
Safety circuit configuration		Duplication not possible	Duplication possible	Duplication not possible	Duplication possible
Drive-source cutoff method		Internal relay cut-off	External safety circuit	Internal relay cut-off	External safety circuit
Emergency stop input		Normally-closed input (Internal power supply)	Normally-closed input (External power supply, duplication possible)	Normally-closed input (Internal power supply)	Normally-closed input (External power supply, duplication possible)
Enable input		Normally-closed input (Internal power supply)	Normally-closed input (External power supply, duplication possible)	Normally-closed input (Internal power supply)	Normally-closed input (External power supply, duplication possible)
Speed setting		1mm/s~ Upper limit depends on the actuator specification			
Acceleration/ deceleration setting		0.01G~ Upper limit depends on the actuator specification			
Programming language		Super SEL language			
No. of programs		255 programs			
No. of program steps		20000 steps (total)			
No. of multi-tasking programs		16 programs			
No. of positions		Varies by the number of controlled axes 1-axis: 55000; 2-axis: 47142; 3-axis: 41250; 4-axis: 36666; 5-axis: 33000; 6-axis: 30000; 7-axis: 27500; 8-axis: 25384			
Data recording element		Flash ROM + non-volatile RAM (FRAM): system battery (button battery) not required			
Data input method		Teaching pendant or PC software			
Standard I/O		I/O 48-point PIO board (NPN/PNP), I/O 96-point PIO board (NPN/PNP) 2 boards attachable			
Serial communication function		Teaching port (D-sub25 pin), USB port (Mini-B) 1ch RS232C port (D-sub 9 pin), Ethernet (RJ-45)			
Fieldbus communication function		DeviceNet, CC-Link, PROFIBUS-DP, EtherNet/IP, EtherCAT (EtherNet/IP, EtherCAT and DeviceNet, CC-Link, PROFIBUS-DP can be simultaneously attached)			
Clock function		Retention time: about 10 days Charging time: about 100 hours			
Regenerative resistance		Built-in 1kΩ/20W regenerative resistor (Can be expanded by external regenerative resistance unit connection)			
Absolute battery		AB-5 (built into the controller)			
Protection function		Motor overcurrent, overload, motor driver temperature check, overload check, encoder disconnection detection, soft limit over, system malfunction, absolute battery abnormality, etc.			
Weight	Without absolute battery unit	[4-axis] about 4.4kg [8-axis] about 5.3kg	[4-axis three-phase] about 3.8kg [4-axis single phase] about 4.4kg [8-axis three-phase] about 4.7kg [8-axis single phase] about 5.3kg	[4-axis] about 4.4kg [8-axis] about 5.3kg	[4-axis] about 3.8kg [8-axis] about 4.7kg
	With absolute battery unit	[4-axis] about 5.0kg [8-axis] about 6.0kg	[4-axis three-phase] about 4.4kg [4-axis single phase] about 5.0kg [8-axis three-phase] about 5.4kg [8-axis single phase] about 6.0kg	[4-axis] about 5.0kg [8-axis] about 6.0kg	[4-axis] about 4.4kg [8-axis] about 5.4kg
Ambient temperature, humidity and environment		0 ~ 40°C, 85% RH or less (non-condensing), avoid corrosive gas and excessive dust			

* For the power supply capacity etc., please refer to the operation manual or contact IAI.

External Dimensions

■ XSEL-RA/SA

	Controller Spec.		Front View		Side View
			Battery-less absolute spec./Incremental spec./ Quasi absolute spec./Index absolute spec.	Absolute spec./Multi-rotation absolute spec.	
RA	Single-phase/ Three-phase spec.	1~4-axis spec.			
		5~8-axis spec.			
SA	Single-phase spec.	1~4-axis spec.			
		5~8-axis spec.			
	Three-phase spec.	1~4-axis spec.			
		5~8-axis spec.			

* If any one of the connected axes is of absolute specification, the external dimensions will be that of the absolute specification.

■ XSEL-RAX/RAXD/SAX/SAXD

	Controller Spec.		Front View		Side View
			Battery-less absolute spec./Incremental spec./ Quasi absolute spec./Index absolute spec.	Absolute spec./Multi-rotation absolute spec.	
RAX RAXD	Three-phase spec.	4-axis spec.			
		5~8-axis spec.			
SAX SAXD	Three-phase spec.	4-axis spec.			
		5~8-axis spec.			

* If any one of the connected axes is of absolute specification, the external dimensions will be that of the absolute specification. However, when only connecting the SCARA robot, the external dimensions will be that of the incremental specification as the battery will be attached to the SCARA. Controllers for large type (arm length 700/800) and high-speed type will have the controller size of the 8-axis specification.

Names of Each Part

■ XSEL-RA

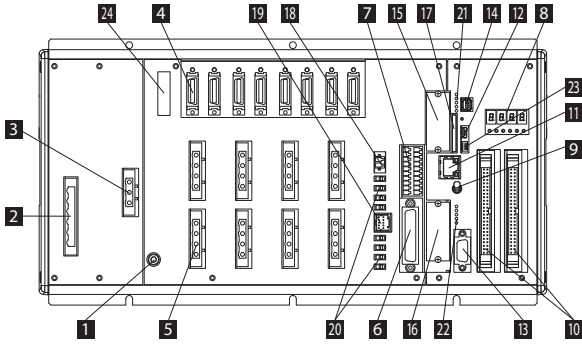

1 FG connection terminal

It is the connection end for connecting the housing FG (Frame ground). Be sure to ground properly for the protection against noise.

2 AC power input connector

A connector for 230VAC three-phase input. It consists of 6 terminals of the motor power terminal, control power supply terminal and PE terminal. It only standardly comes with the terminal block.

Caution Do not touch the connector while power is supplied to avoid an electric shock.

3 External regenerative resistance unit connector

A connector for connecting a regenerative resistor unit that's connected when the capacity is insufficient with the built-in regenerative resistor at high acceleration/high-load, etc. The necessity of an external regenerative resistance unit depends on the application such as the axis configuration.

4 Encoder/axis sensor connector

A connector for connecting an encoder of the actuator and axis sensors such as LS, CREEP, and OT. *: LS, CREEP and OT are optional.

5 Motor connector

A connector for driving the motor of the actuator.

6 Teaching connector

The teaching interface is to be connected to IAI teaching pendant or PC (PC software) for the operation and setting of the controller.

7 System I/O connector

An I/O connector that controls the safety operations of the controller. In the safety category specification, it is possible to configure the safety circuits of up to category 4 with this connector and external safety circuit.

8 Panel window

It consists of 7 segment LEDs with 4 digits and 6 LED lamps that indicate the status of the controller.

9 Mode switch

This switch is used to specify the mode of operation of the controller. It is a lever lock type toggle switch for preventing wrong operation that can be operated by pulling toward the user.

Switch position	Function
MANU (Manual mode) Top	Teaching tool can be used.
AUTO (Automatic mode) Bottom	Teaching tool cannot be used. (Note) Be sure to attach the 6 supplied dummy plug to the teaching connector. If not, the emergency stop cannot be released.

10 Standard I/O connector

48-point I/O or 96-point DIO board (option) is mounted.

11 EtherNet connector

Communication port for connecting the EtherNet communication device.

12 USB connector

USB device connector for connecting to a PC.

13 General RS232C port connector

A port for connecting general RS232C devices.

■ XSEL-SA (Three-phase, with absolute unit)

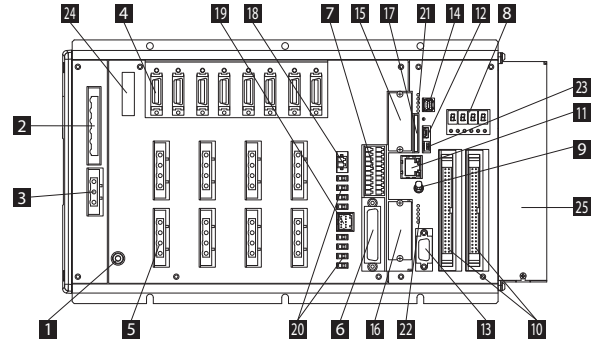

14 Expanded motion control connector

A connector for IAI controllers (MECHATROLINK III specification).

15 Field network board (optional) mounting position 1

Equipped with the field network board (option) for EtherNet/IP or EtherCAT.

16 Field network board (optional) mounting position 2

Equipped with the field network board (option) for CC-Link, DeviceNet or PROFIBUS-DP.

17 SD card slot connector

A connector to be used for system update. Not used in normal operation.

18 Brake power connector

A power supply connector for the brake of the actuator. External 24VDC power supply is required. If this power is not supplied, the brake of the actuator cannot be released. Make sure to use a power supply for axes with brake.

19 Brake release switch connector

A connector for connecting the switch for releasing the brake of the actuator from the outside of the controller. When short-circuiting the COM terminal and BKMRL⁺ terminal of the connector, the brake will be released. Used for moving the actuator by hand in case of power failure or abnormality of the controller.

20 Brake release switch

A switch to be used to release the brake of the actuator with brake forcibly (released by supplying power). When starting up the device or moving the actuator by hand during teaching or in case of abnormality, switch to the RLS side to force the brake to be released. As long as it is not required, keep the switch to the NOM side.

Switch position	Function
RLS (Brake release) Left	The brake is forcibly released.
NOM (Automatic mode) Right	The brake is automatically controlled by the controller. Servo ON: Brake release Servo OFF: Brake enabled

The switch is not available for the axes with brake of some SCARA robots for the SCARA controllers.

21 System operational status LED lamp 1

Status LED lamps that indicate system operating status (Motion control master, SD card) and the operating status of the network interface 1.

22 System operational status LED lamp 2

Status LED lamps that indicate system operating status (Main CPU) and the operating status of the network interface 2.

23 System operation setting switch

4-pole DIP switch for setting the system operation mode.

24 Conveyor tracking connector

A connector for the conveyor tracking encoder. Standardly equipped for the SCARA controller.

25 Absolute battery unit

The unit will be attached in the absolute specification.

Option

■ Regenerative resistance unit

Model RESU-1 (Standard specification)
RESUD-1 (DIN rail mounting specification)

Specification

Model	RESU-1	RESUD-1
Weight	About 0.4kg	
Built-in regenerative resistance value	235Ω 80W	
Unit mounting method	Screw mount	DIN rail mount
Attached cable	CB-ST-REU010	

Description

Unit that converts the regenerative current generated in motor deceleration to heat. Although the controller is equipped with a regenerative resistance inside, an additional regenerative unit may be necessary if the load in the vertical axis is large and the capacity is insufficient.

<When connecting a single-axis robot>

Installation criteria Determined by the total motor wattage of connected axes.

Horizontal specification

Total motor wattage	Required number of regenerative resistances
100W	0
~600W	1
~1200W	2
~1800W	3
~2400W	4

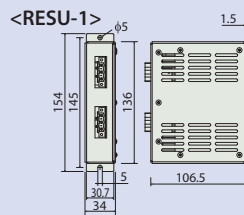

Vertical specification

Total motor wattage	Required number of regenerative resistances
100W	0
~600W	1
~1000W	2
~1400W	3
~2000W	4
~2400W	5

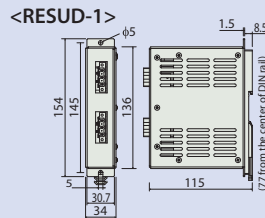

<When connecting a SCARA robot>

Estimated installation criteria

Model Number	Required number of regenerative resistances
1205	0
1505	
1805	
NNN	1
NNW	
TNN	
UNN	3
HNN	
INN	
NNC	4
70**H	
80**H	
10040	4
12040	
NSN	3
5016H	
6016H	

* The required number is for a single SCARA robot. When connecting a single-axis robot as an additional axis, be sure to add regenerative resistances for the single-axis robot.

Examples: When operating IX-NNN2515H and ISA-MXM (200W).
IX-NNN2515H 1 unit required
ISA-MXM (200W) ... 1 unit required
Therefore, 2 regenerative resistances are required.

■ Absolute data backup battery

Model AB-5

Features Absolute data storage battery for operating an actuator of the absolute specification.



■ Dummy plug

Model DP-2

Features A dummy plug to be attached to the teaching connector when a PC or teaching pendant is not connected.



Touch panel teaching pendant

Features A teaching device equipped with functions such as position teaching, trial operation, and monitoring.

Model TB-02-□

External dimensions

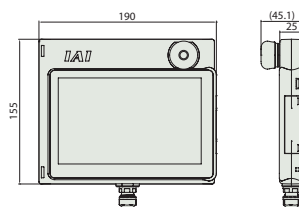

Specification

Rated voltage	24VDC
Power consumption	3.6W or less (150mA or less)
Ambient operating temperature	0~40°C
Ambient operating humidity	20~85% RH (Non-condensing)
Environmental resistance	IP20
Weight	470g (TB-02 unit only)

PC software (For XSEL-RA/RXA/RXAD)

Model IA-101-X-MW

Features This is start-up support software which comes equipped with functions such as program/position input, trial operation and monitoring.
The functions required for debugging has been significantly improved to reduce the start-up time.

Description Software (CD-ROM), supported Windows: XP SP2 or later/Vista/7/8

(Accessories) PC connection cable 5m + emergency stop box (Model CB-ST-E1MW050-EB)

Notes
 * When using a Safety Category 4 compliant controller, please use IA-101-XA-MW.
 * It cannot be used for XSEL-SA/SAX/SAXD.
 * When separately ordering a PC connection cable for maintenance, the model number will be CB-ST-E1MW050 for the cable only and CB-ST-E1MW050-EB when set with an emergency stop box.

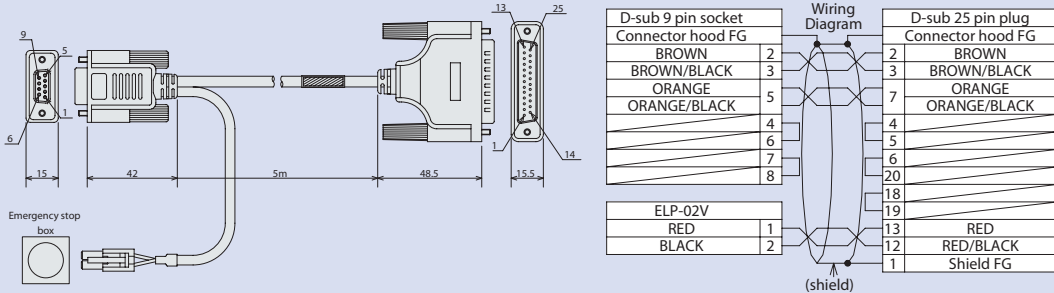

Safety category 4 compliant PC software (for XSEL-SA/SAX/SAXD)

Model IA-101-XA-MW * Only for XSEL-SA/SAX/SAXD.

Features This is start-up support software which comes equipped with functions such as program/position input, trial operation and monitoring.
The functions required for debugging has been significantly improved to reduce the start-up time.
In addition, the PC connection cable has a duplex circuit for emergency stop to comply to the Safety Category 4.

Description Software (CD-ROM), supported Windows: XP SP2 or later/Vista/7/8

(Accessories) PC connection cable 5m + Emergency stop box (Model: CB-ST-A1MW050-EB)

Notes
 When separately ordering a PC connection cable for maintenance, the model number will be CB-ST-A1MW050 for the cable only and CB-ST-A1MW050-EB when set with an emergency stop box.
 If you do not use a teaching tool, connect the dummy plug DP-2 that comes with the controller to the teaching connector.

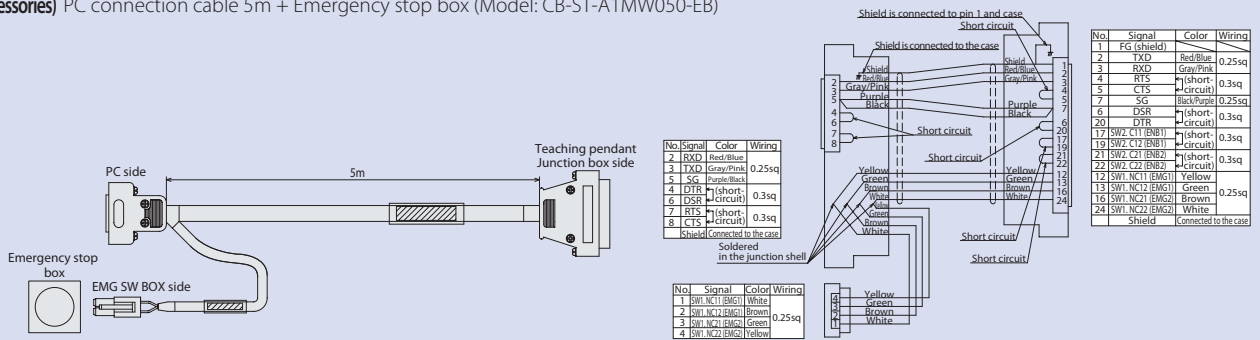

USB compliant PC software (For XSEL-RA/RXA/RXAD)

Model IA-101-X-USBW

Features A USB adapter is mounted on the RS232C cable to allow the use on a PC's USB port.

Description Software (CD-ROM), supported Windows: XP SP2 or later/Vista/7/8

(Accessories) PC connection cable 5m + emergency stop box + USB adapter + USB cable 3m

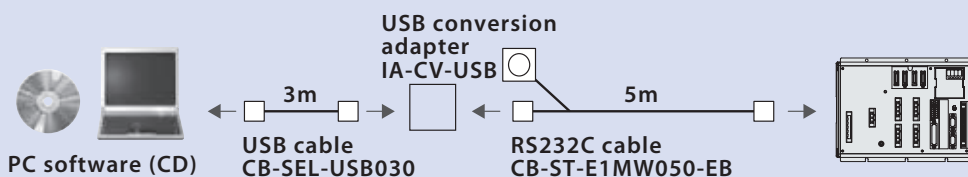

PC software (no cable)

Model IA-101-N

Features It only comes with the PC software (CD-ROM). If you want to connect both the controller and PC side with a USB cable or Ethernet cable, only the software needs to be purchased. A cable that meet the following specifications is to be prepared by the customer.

Notes
When operating the actuator by USB connection, be sure to connect the stop switch to the system I/O connector.
If an emergency switch is not available, use the emergency stop-equipped model "IA-101-X-USBMW".

Description Software (CD-ROM), supported Windows: XP SP2 or later/Vista/7/8

	Controller side connector	Maximum cable length
USB cable specification	USB Mini-B	5m
Ethernet cable specification	10/100/1000BASE-T (RJ-45)	5m



PC software (CD)

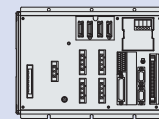
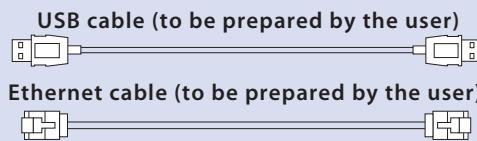

Maintenance Parts

When placing an order for the replacement cable, please use the model number shown below.

■ Table of compatible cables

Model number		Motor cable	Motor robot cable	Encoder cable	Encoder robot cable
①	RCS2 (CR/W) RCS3 (CR)	CB-RCC-MA□□□□	CB-RCC-MA□□□□-RB CB-XEU-MA□□□□ (EU version)	CB-RCS2-PA□□□□	CB-X3-PA□□□□ CB-XEU3-PA□□□□ (EU vers.)
②	Models other than ② ~ ④ RT			CB-RCS2-PLA□□□□	CB-X2-PLA□□□□/CB-XEU2-PLA□□□□ (EU vers.)
③	RA13R (Without load cell/ without brake)			CB-RCS2-PLA□□□□	CB-X2-PLA□□□□ CB-XEU2-PLA□□□□ (EU vers.)
④	RA13R (Without load cell/ with brake)			CB-RCS2-PLA□□□□ [Between the controller and brake] CB-RCS2-PLA□□□□	CB-X2-PLA□□□□/CB-XEU2-PLA□□□□ (EU vers.) [Between the controller and brake] CB-X2-PLA□□□□/CB-XEU2-PLA□□□□ (EU vers.)
⑤	NS	Without LS	CB-X-MA□□□□	—	CB-X3-PA□□□□/CB-XEU3-PA□□□□ (EU vers.)
⑥		With LS	CB-XEU-MA□□□□ (EU version)	—	CB-X2-PLA□□□□/CB-XEU2-PLA□□□□ (EU vers.)
⑦	—	—	—	—	—
⑧	DD DDA DDCR DDACR DDW	—	CB-X-MA□□□□ CB-XEU-MA□□□□ (EU vers.)	—	CB-X3-PA□□□□ CB-XEU3-PA□□□□ (EU version)
⑨			T18□□/ LT18□□	CB-XMC-MA□□□□ CB-XEUMC-MA□□□□ (EU vers.)	
⑩	ISWA	—	CB-XEU-MA□□□□	—	CB-X1-PA□□□□-WC
⑪	—	—	—	—	—
⑫	Models other than ① ~ ⑪	—	CB-X-MA□□□□ CB-XEU-MA□□□□ (EU version)	—	*(For 20m or less) CB-X1-PA□□□□ CB-XEU1-PA□□□□ (EU vers.)
⑬		Models other than ① ~ ⑪ with LS		—	—
⑭	IX (Joint cable specification)			—	—
⑮		—		—	—
⑮	IX (Joint cable specification)	—	CB-X-MA□□□□ CB-XEU-MA□□□□ (EU vers.)	—	CB-X1-PA□□□□ CB-XEU1-PA□□□□ (EU vers.)

* Those that do not have the battery-less absolute specification will also be CB-X(EU)1-PA□□□□/CB-X(EU)1-PLA□□□□ for over 20m.

Model number	PIO flat cable
⑮ XSEL- RA/SA/RAX/RAXD/SAX/SAXD	CB-X-PIO□□□□
	Multipoint PIO flat cable
	CB-X-PIOH□□□□

Maintenance Parts

Model number	CB-RCC-MA □□□	Motor cable	for RCS2 / RCS3
	CB-RCC-MA □□□- RB	Motor robot cable	
	CB-X-MA □□□	Motor robot cable	for models other than RCS2 / RCS3 / DD(A)-H/LH18
	CB-XEU-MA □□□	EU motor robot cable	for RCS2 / RCS3 and other models (Note)

* Enter the cable length (L) into □□□. Compatible to a Maximum of 30 meters.
Ex.: 080 = 8m

(Fig.: Motor cable CB-RCC-MA□□□ / CB-RCC-MA□□□-RB / CB-X-MA□□□ with plastic connector)

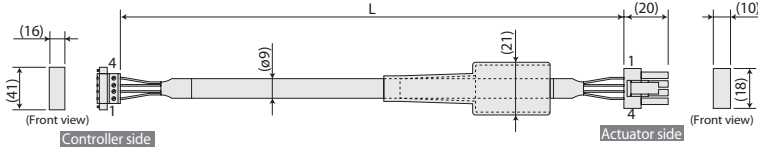

Minimum bending R: r = 51 mm or more (for movable use)
* If the cable must be guided in a cable track, use a robot cable.

Wire	Color	Signal	No.	No.	Signal	Color	Wire
0.75sq	Green	PE	1	1	U	Red	0.75sq (crimped)
	Red	U	2	2	V	White	
	White	V	3	3	W	Black	
	Black	W	4	4	PE	Green	

(Fig.: EU motor robot cable CB-XEU-MA□□□, EU version with M18 plastic round connector)

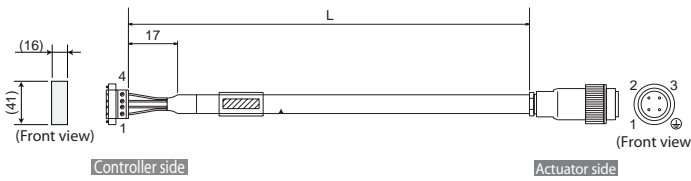

Minimum bending R: r = 51 mm or more (for movable use)
* Only robot cable is available for this model

Wire	Color	Signal	No.	No.	Signal	Color	Wire
0.75sq	Green/yellow	PE	1	⊕	PE	Green/yellow	0.75sq (crimped)
	Black/white*1"	U	2	1	U	Black/white*1"	
	Black/white*2"	V	3	2	V	Black/white*2"	
	Black/white*3"	W	4	3	W	Black/white*3"	

Model number	CB-RCS2-PA □□□	Encoder cable	for RCS2 / RCS3
	CB-X3-PA □□□	Encoder robot cable	for NS / RCS2 / RCS3
	CB-XEU3-PA □□□	EU encoder robot cable	

* Enter the cable length (L) into □□□. Compatible to a Maximum of 30 meters.
Ex.: 080 = 8m

(Fig.: Encoder cable CB-RCS2-PA□□□ / CB-X3-PA□□□ with plastic connector)

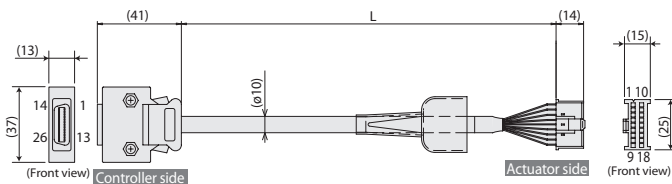

Minimum bending R: r = 58 mm or more (for movable use)
* If the cable must be guided in a cable track, use a robot cable.

Wire	Color	Signal	No.	No.	Signal	Color	Wire
-	-	-	10	1	A	White/blue	AWG26 (soldered)
-	-	-	11	2	A	White/yellow	
-	-	E24V	12	3	B	White/red	
White/green	OV	13	4	4	B	White/black	
White/orange	LS	26	5	5	Z	White/purple	
-	CREEP	25	6	6	Z	White/gray	
-	OT	24	7	7	LS+	White/orange	
-	RSV	23	8	8	-	-	
-	-	9	9	9	FG	(Ground)	
-	-	18	10	10	SD	Orange	
-	-	19	11	11	SD	Green	
White/blue	A+	1	12	12	BAT+	Purple	
White/yellow	A-	2	13	13	BAT-	Gray	
White/red	B+	3	14	14	VCC	Red	
White/black	B-	4	15	15	GND	Black	
White/purple	Z+	5	16	16	LS-	White/green	
White/gray	Z-	6	17	17	BK-	Blue	
Orange	SRD+	7	18	18	BK+	Yellow	
Green	SRD-	8	-	-	-	-	
Purple	BAT+	14	-	-	-	-	
Gray	BAT-	15	-	-	-	-	
Red	VCC	16	-	-	-	-	
Black	GND	17	-	-	-	-	
Blue	BKR-	20	-	-	-	-	
Yellow	BKR+	21	-	-	-	-	
-	-	22	-	-	-	-	

The shield is connected to the hood by a clamp.

Ground wire and braided shield

(Fig.: EU encoder robot cable CB-XEU3-PA□□□, EU version with metal connector)

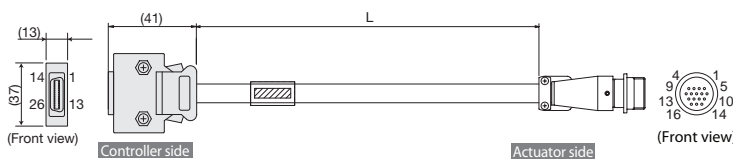

Minimum bending R: r = 58 mm or more (for movable use)

Wire	Color	Signal	No.	No.	Signal	Color	Wire
-	-	-	10	1	SD	Orange	AWG26 (soldered)
-	-	-	11	2	SD	Green	
-	-	E24V	12	3	A+	White/blue	
White/green	OV	13	4	4	A-	White/yellow	
White/orange	LS	26	5	5	LS+	White/orange	
-	CREEP	25	6	6	B+	White/red	
-	OT	24	7	7	B-	White/black	
-	RSV	23	8	8	Z+	White/purple	
-	-	9	9	9	Z-	White/gray	
-	-	18	10	10	VCC	Red	
-	-	19	11	11	GND	Black	
White/blue	A+	1	12	12	BAT+	Purple	
White/yellow	A-	2	13	13	BAT-	Gray	
White/red	B+	3	14	14	LS-	White/green	
White/black	B-	4	15	15	BK-	Blue	
White/purple	Z+	5	16	16	BK+	Yellow	
White/gray	Z-	6	17	17	-	-	
Orange	SRD+	7	18	18	-	-	
Green	SRD-	8	-	-	-	-	
Purple	BAT+	14	-	-	-	-	
Gray	BAT-	15	-	-	-	-	
Red	VCC	16	-	-	-	-	
Black	GND	17	-	-	-	-	
Blue	BKR-	20	-	-	-	-	
Yellow	BKR+	21	-	-	-	-	
-	-	22	-	-	-	-	

The shield is stamped to the hood

Ground wire and braided shield

A shield is connected to shield soldered part

Maintenance Parts

Model number	CB-RCS2-PLA □□□	Limit switch encoder cable	for RCS2 Rotary type
	CB-X2-PLA □□□	Limit switch encoder robot cable	for LS specification models
	CB-XEU2-PLA □□□	EU limit switch encoder robot cable	NS / RCS2 Rotary type

* Enter the cable length (L) into □□□. Compatible to a Maximum of 30 meters.
Ex: 080 = 8m

(Fig.: LS encoder cable CB-RCS2-PLA□□□ / CB-X2-PLA□□□ with plastic connector)

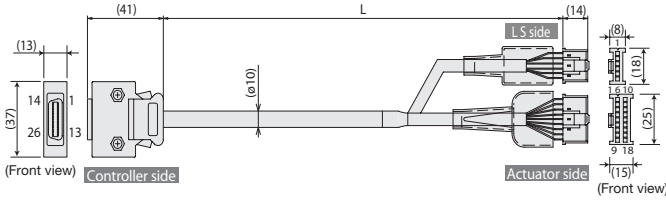

Minimum bending R: r = 58 mm or more (for movable use)
* If the cable must be guided in a cable track, use a robot cable.

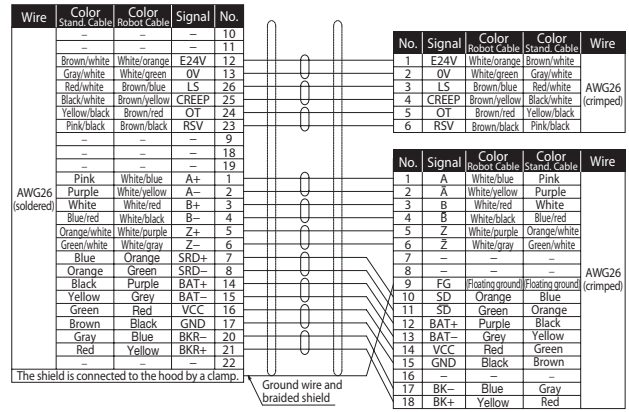

("Brown/white" in cable color indicates the colors of line/insulator.)

(Fig.: EU LS encoder robot cable CB-XEU2-PLA□□□, EU version with metal connector)

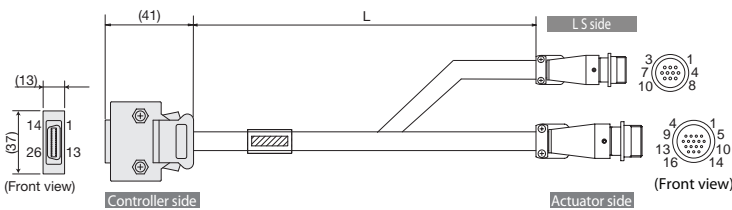

Minimum bending R: r = 58 mm or more (for movable use)

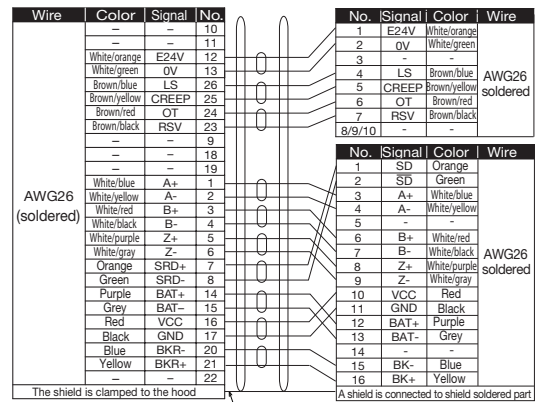

("White/orange" in cable color indicates the colors of line/insulator.)

Model number	CB-X1-PA □□□	Encoder robot cable	for models other than NS / RCS2 / RCS3 / DD(A)
	CB-XEU1-PA □□□	EU encoder robot cable	

* Enter the cable length (L) into □□□. Compatible to a Maximum of 30 meters.
Ex: 080 = 8m

(Fig.: Encoder robot cable CB-X1-PA□□□ with plastic connector)

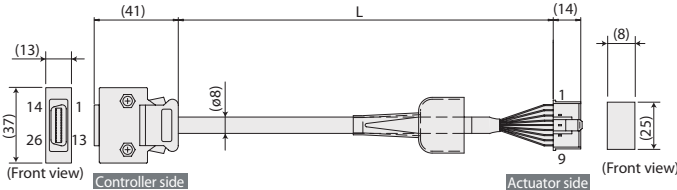

Minimum bend radius R: r = 44mm or larger (for movable use)

*Only robot cable is available for this model.
*If you require ISB/ISDB/ISDBCR (encoder type is battery-less absolute) with the cable of 21m or longer, select the CB-X1-PA□□□-AWG24.

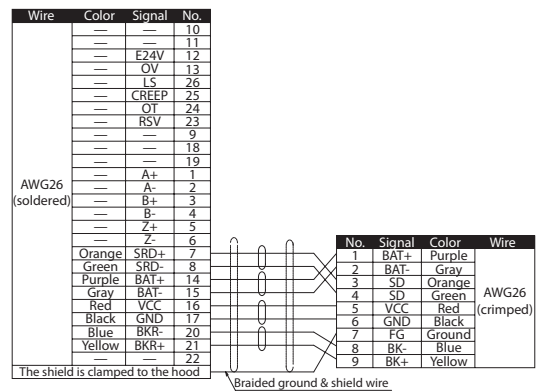

(Fig.: EU encoder robot cable CB-XEU1-PA□□□, EU version with metal connector)

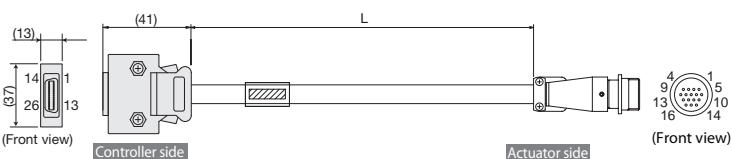

Minimum bend radius R: r = 44mm or larger (for movable use)

*Only robot cable is available for this model.
*If you require ISB/ISDB/ISDBCR (encoder type is battery-less absolute) with the cable of 21m or longer, select the CB-XEU1-PA□□□-AWG24.

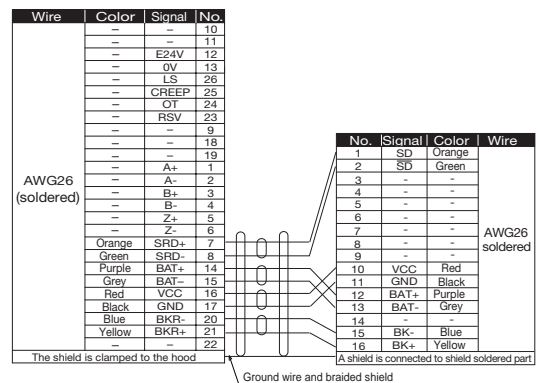

Maintenance Parts

Model number	CB-X1-PA <input type="checkbox"/> <input type="checkbox"/> <input type="checkbox"/> <input type="checkbox"/> - AWG24	Encoder low-resistance robot cable	for models with battery-less absolute encoder other than NS / RCS2 / RCS3
	CB-XEU1-PA <input type="checkbox"/> <input type="checkbox"/> <input type="checkbox"/> <input type="checkbox"/> - AWG24	EU encoder low-resistance robot cable	

* Enter the cable length (L) into . Compatible to a Maximum of 30 meters.
Ex: 210 = 21m

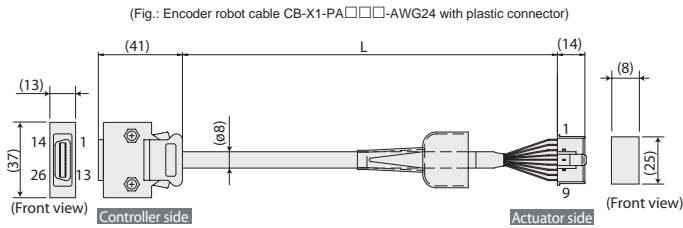

Minimum bend radius R: r = 44mm or larger (for movable use)
*Only robot cable is available for this model.

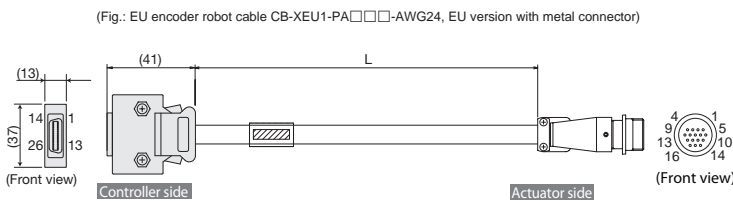
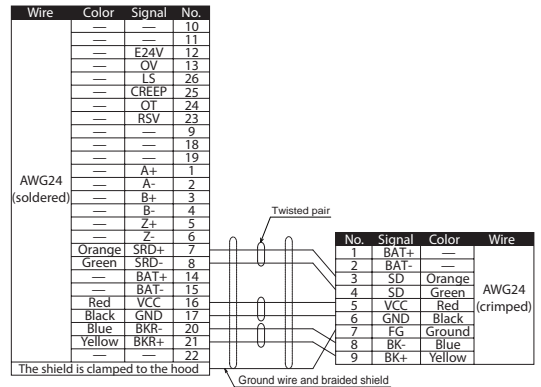

Minimum bend radius R: r = 44mm or larger (for movable use)
*Only robot cable is available for this model.

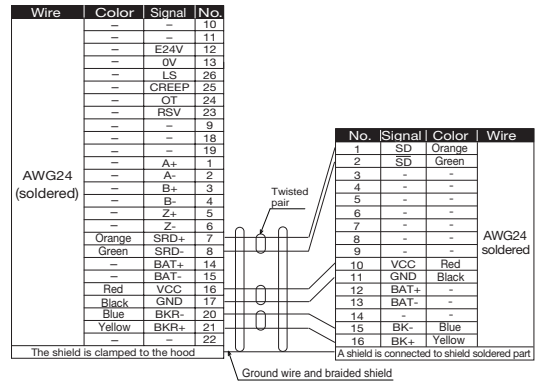

Model number	CB-X1-PLA <input type="checkbox"/> <input type="checkbox"/> <input type="checkbox"/> <input type="checkbox"/>	Limit switch encoder robot cable	for LS specification models other than NS / RCS2 / RCS3
	CB-XEU1-PLA <input type="checkbox"/> <input type="checkbox"/> <input type="checkbox"/> <input type="checkbox"/>	EU limit switch encoder robot cable	

* Enter the cable length (L) into . Compatible to a Maximum of 30 meters.
Ex: 080 = 8m

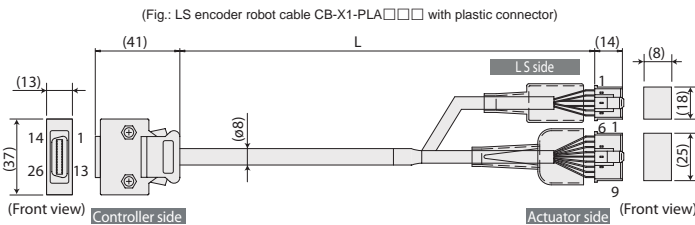

Minimum bend. radius R: r = 54mm or larger (for movable use)
*Only robot cable is available for this model.

*If you require ISB/ISDB/ISDBCR (encoder type is battery-less absolute) with the cable of 21m or longer, select the CB-X1-PLA-AWG24.

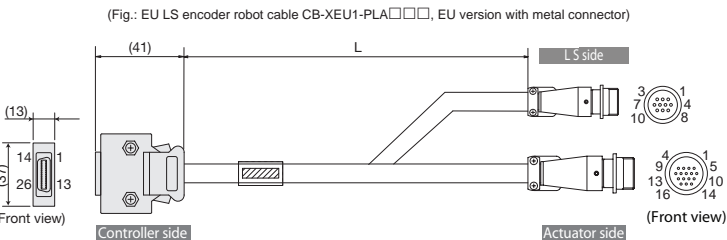
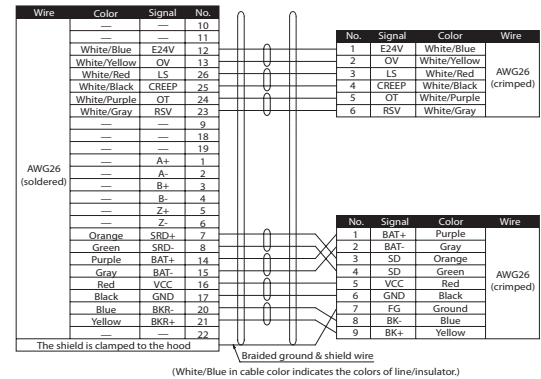

Minimum bend. radius R: r = 54mm or larger (for movable use)
*Only robot cable is available for this model.

*If you require ISB/ISDB/ISDBCR (encoder type is battery-less absolute) with the cable of 21m or longer, select the CB-XEU1-PLA-AWG24.

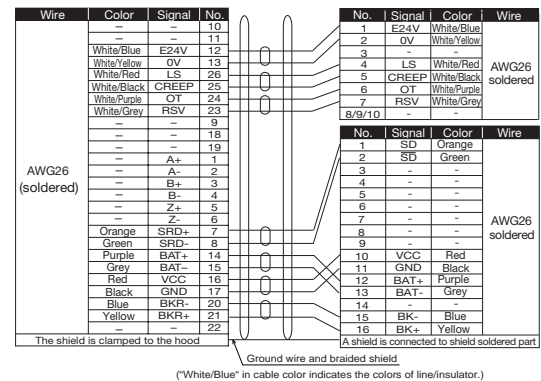

**XSEL-RA/SA Series
Catalogue No. 1016-E**



The information contained in this catalog is subject to change without notice for the purpose of product improvement



IAI Industrieroboter GmbH

Ober der Röth 4
65824 Schwalbach
Germany
Tel.: +49-6196-8895-0
Fax: +49-6196-8895-24
E-Mail: info@iai-automation.com
<http://www.iai-automation.com>

IAI America, Inc.

2690 W. 237th Street, Torrance, CA 90505, U.S.A
Phone: +1-310-891-6015, Fax: +1-310-891-0815

IAI (Shanghai) Co., Ltd

Shanghai Jiahua Business Center A8-303, 808,
Hongqiao Rd., Shanghai 200030, China
Phone: +86-21-6448-4753, Fax: +86-21-6448-3992

IAI CORPORATION

577-1 Obane, Shimizu-Ku, Shizuoka, 424-0103 Japan
Phone: +81-543-64-5105, Fax: +81-543-64-5192

IAI Robot (Thailand) Co., Ltd

825 PhairojKijja Tower 12th Floor, Bangna-Trad RD.,
Bangna, Bangna, Bangkok 10260, Thailand
Phone: +66-2-361-4457, Fax: +66-2-361-4456