

To: All customers and all distributors

Production-Discontinuation: PCON-C/CG/CF

November 2022

Dear Sir and Madam,

Thank you for being our valued customer. We appreciate your continued business and support.

Due to difficulty of continuing to produce the following models, we regret to announce herewith a production discontinuation.

- | | |
|-------------------------------|---|
| 1. Affected models | : PCON-C/CG, PCON-CF |
| 2. Reason for discontinuation | : Difficult availability of the CPU and electric components used in this product |
| 3. Successor models | : PCON-CB/CGB, PCON-CFB
Please find the next pages for the detail. |
| 4. Order cutoff date | : 23 June 2023 |
| 5. Repair service cutoff date | : 23 June 2033
* We may have to stop the service earlier if the corresponding spare parts are no longer available. |

We sincerely apologize for any inconvenience caused by the discontinuation of the products and ask for your understanding and cooperation.

Best regards,

IAI Industrieroboter GmbH
Ober der Röth 4
65824 Schwalbach am Taunus
Tel.: +49-6196-8895-0, Fax: +49-6196-8895-24
E-Mail: info@iai-automation.com, Web: iai-automation.com

Differences between PCON-C/CG/CF and PCON-CB/CGB/CFB

1. Difference in Fieldnetwork module
 - Except in CC-Link, EtherCAT, and PROFINET, field network configuration files need to be changed
2. Parameter file and backup file are different
 - RC PC-software can convert the position data from C/CG/CF to CB/CGB/CFB.
 - TB-01/02/03 doesn't support conversion.
3. Old teaching pendants are not compatible with PCON-CB/CGB/CFB.
 - CON-T, CON-PT and RCM-PM-01 are not compatible.
4. Due to the different cable connections on the controller side, the motor/encoder cables intended for PCON-C/CG/CF cannot be used directly for PCON-CB/CGB/CFB. For this, it is necessary to either change the motor/encoder cables or to connect them to the PCON-CB/CGB/CFB via the following adapter parts.

<Adapter parts> for continued use of the cables intended for PCON-C/CG/CF

- Converter (Model: JCN-MPG-PCA)
- Adapter cable (Model: CB-PACA-CNB002)

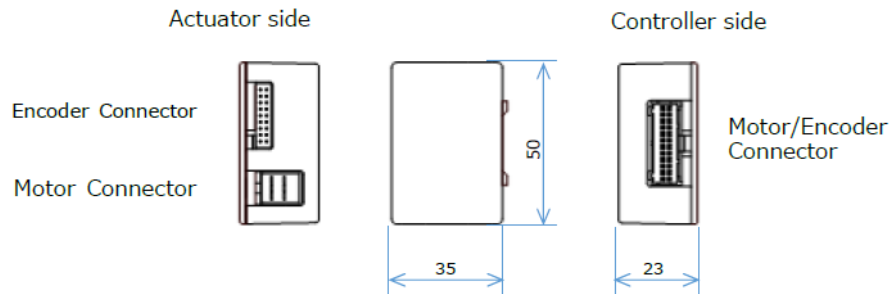

The external view and the part names of the converter (Model: JCN-MPG-PCA)

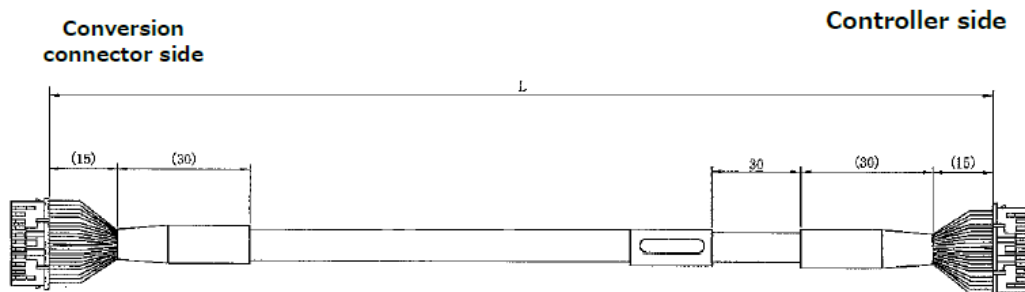

The external view of the adapter cable (Model: CB-PACA-CNB)

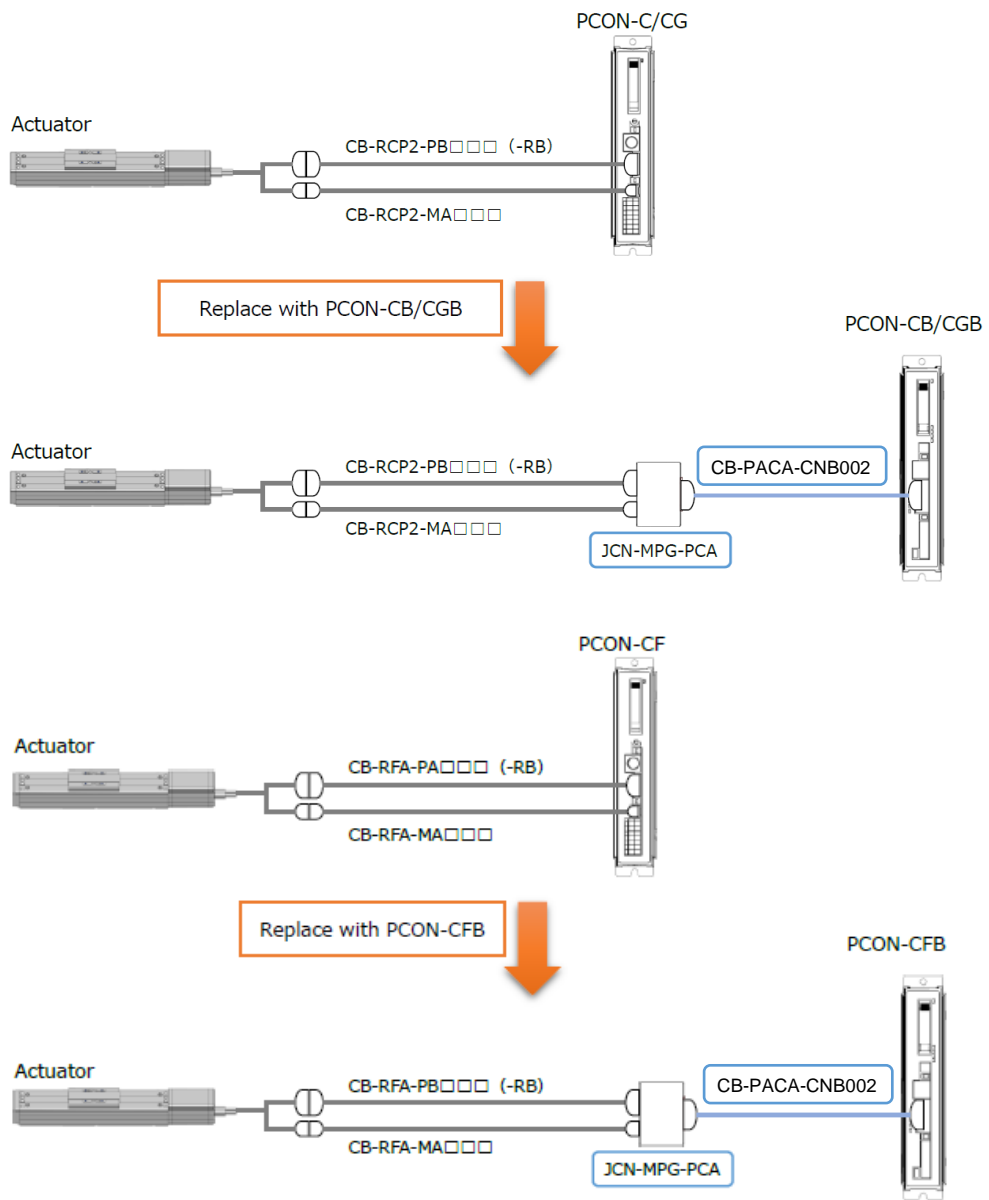

Replacement example of incremental type

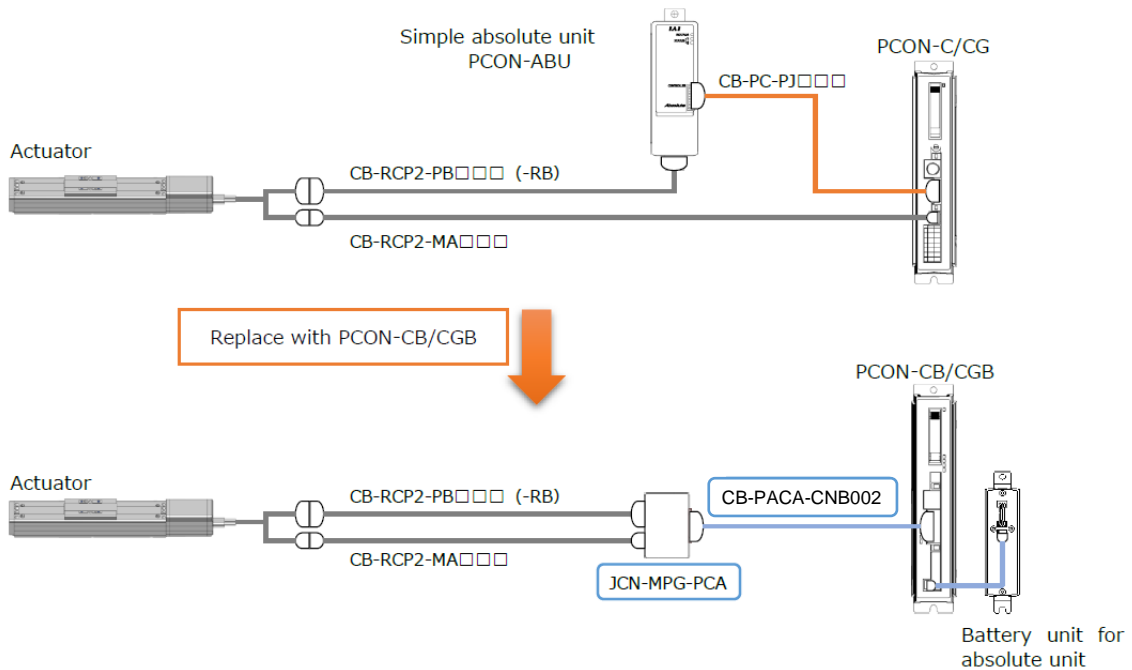

Replacement example of simple absolute type

Compatibility with PCON-CB/CGB/CFB

- Product dimensions of the main body of PCON-CB/CGB
- Mounting dimensions of the screw mounting type
- Serial communication via RS485 interface
- Wiring for the power supply and emergency stop circuit: PCON-CB/CGB/CFB has an additional input for the brake release, but can be used without its wiring. However, the connector of the power supply and emergency stop changes to a plug connector.
- Pin assignment, function assignment and cable type at the digital input / output (I / O)